



YAMAHA MBK 

YN50 ²⁰⁰²
5RN-AE1

SERVICE MANUAL

YN50
SERVICE MANUAL
© 2002 Yamaha Motor España, S.A.
First Edition, September 2002
All rights reserved.
The reprinting or use of this material without
the written authorisation of Yamaha Motor
España, S.A is forbidden.
Printed in Spain.

WARNING

This Manual was written by Yamaha Motor España, S.A. principally for the use of Yamaha/MBK agents and qualified mechanics. As it is not possible to give full mechanical instructions in a manual, it is presumed that the persons using the book to carry out the maintenance and repair of Yamaha/MBK motorcycles have a basic knowledge of the concepts and procedures inherent in the technology of motorcycle repair. Without such knowledge any attempt to repair or service this model may cause problems in its use and/or safety.

Yamaha Motor España, S.A., is continually trying to improve all models which it manufactures. Authorised Yamaha/MBK agents will be notified of all significant modifications and changes in the specifications or procedures and these will appear where applicable in future editions of this manual.

PARTICULARLY IMPORTANT INFORMATION

This material used the following notation.



A danger symbol means ATTENTION, BE CAREFUL, YOUR SAFETY IS IN DANGER!

WARNING

Non-compliance with a WARNING *may cause the serious injury or death* of the driver, a bystander or the person inspecting of repairing the motorcycle.

ATTENTION:

ATTENTION indicates the special precautions which should be taken in order to avoid damage to the motorcycle.

NOTE:

NOTE provides key information to make the procedures easier and clearer.

HOW TO USE THIS MANUAL

FORMAT OF THIS MANUAL

This manual is composed of chapters on the main subject categories (See "Illustrated Symbols"). First heading ①: This is a chapter with a symbol at the top right-hand side of each page.

Second heading ②: This title appears at the top of each page to the left of the chapter symbol. (For the "Inspection and periodic adjustments" chapter the third heading appears)

Third heading ③: This is a final heading.

MANUAL FORMAT

All procedures in this manual are organised sequentially, step by step. The information has been compiled to make reading easy for the mechanic and to provide useful reference material which contains ample explanations of all disassembly, repair, assembly and inspection procedures. A particularly important procedure ④ is placed between a lines of asterisks "*" with each procedure preceded by "•".









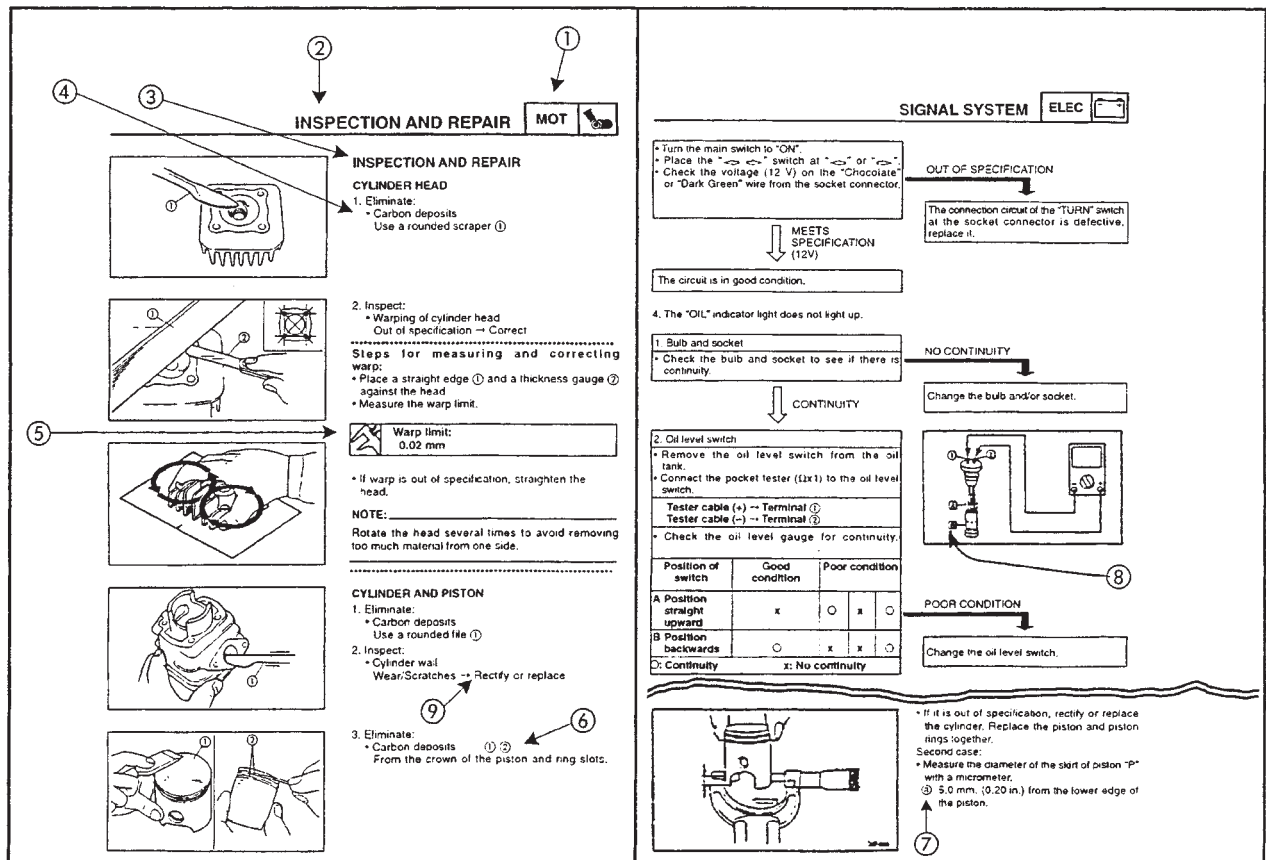







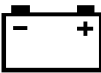

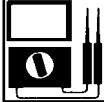

IMPORTANT CHARACTERISTICS

- Data and special tools are put in a box preceded by a corresponding symbol ⑤.
- A number within a circle ⑥ indicates the number of a part, and an alphabetical letter within a circle indicates data or an alignment mark ⑦, everything else is indicated by a letter within a box ⑧.
- The conditions of defective components will precede an arrow symbol and the course of action to be followed will follow the symbol ⑨.

DETAILED DIAGRAM

Each chapter provides detailed diagrams before each disassembly section, for the easy identification of disassembly/assembly procedures.



① GEN INFO 	② SPEC 	
③ INSP/ ADJ 	④ ENG 	
⑤ CARB 	⑥ CHAS 	
⑦ ELEC 	⑧ TRBL/ SHTG ?	
⑨ 	⑩ 	
⑪ 	⑫ 	
⑬ 	⑭ 	
⑮ 		
⑯ 	⑰ 	⑱ 
⑲ 	⑳ 	㉑ 
㉒ 	㉓ NEW	

ILLUSTRATED SYMBOLS

(See illustration)

Illustrated symbols ① to ⑧ are designed as tabs to be followed with the thumb to indicate the chapter number and the index.

- ① General information
- ② Specifications
- ③ Periodic inspection and adjustment
- ④ General overhaul of the engine
- ⑤ Carburation
- ⑥ Chassis
- ⑦ Electrical system
- ⑧ Troubleshooting









Illustrated symbols ⑨ to ⑮ will be used to identify the specifications which appear in the text.

- ⑨ Refill with fluid
- ⑩ Lubricant
- ⑪ Special tool
- ⑫ Tightening
- ⑬ Wear limit, clearance
- ⑭ Engine speed
- ⑮ Ω V, A

Illustrated symbols ⑯ to ㉓ of detailed diagrams, indicate the degree of lubricant and the location of the lubrication point.

- ⑯ Apply engine oil
- ⑰ Apply gear oil
- ⑱ Apply molybdenum disulphide oil
- ⑲ Apply grease to wheel bearings
- ⑳ Apply grease with lightweight lithium soap base
- ㉑ Apply molybdenum disulphide grease
- ㉒ Apply bonding agent (LOCTITE®)
- ㉓ Use a new part.

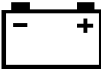
INDEX

GENERAL INFORMATION	
	GEN/ INFO 1
SPECIFICATIONS	
	SPEC 2
PERIODIC INSPECTION AND ADJUSTMENTS	
	INSP ADJ 3
GENERAL OVERHAUL OF ENGINE	
	ENG 4
CARBURATION	
	CARB 5
CHASSIS	
	CHAS 6
ELECTRICAL SYSTEM	
	ELEC 7
TROUBLESHOOTING	
	TRBL SHTG 8

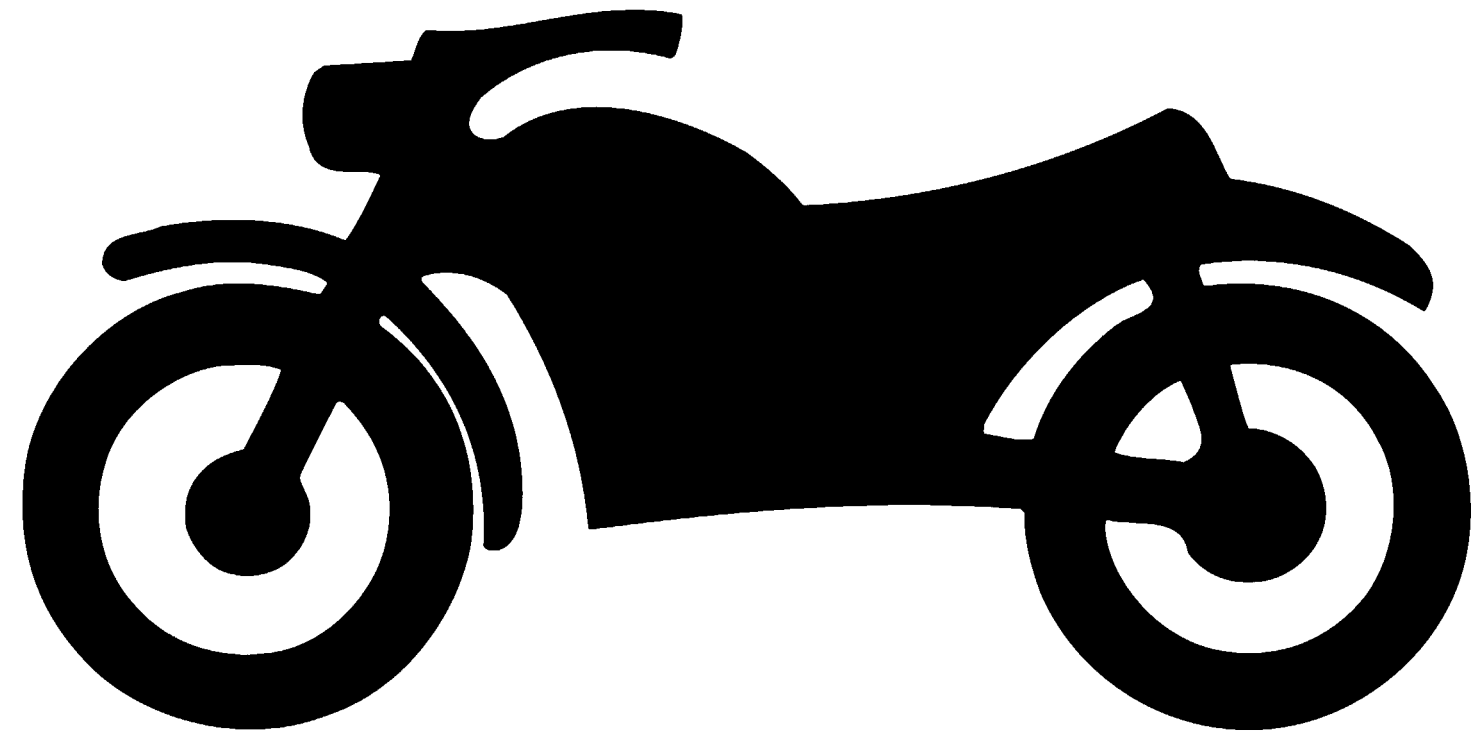

**GEN/
INFO**

1

CHAPTER 1 GENERAL INFORMATION

IDENTIFICATION OF THE SCOOTER	1-1
SERIAL NUMBER OF THE FRAME	1-1
ENGINE SERIAL NUMBER.....	1-1
IMPORTANT INFORMATION	1-2
CHANGE OF ALL PARTS	1-2
OIL SEALS AND O-RINGS	1-2
SEALING WASHERS/PLATE AND KEYS.....	1-2
BEARING AND OIL SEALS	1-2
CIRCLIPS	1-3
SPECIAL TOOLS	1-3
FOR SERVICING THE ENGINE	1-3
FOR SERVICING THE CHASSIS	1-5
FOR ELECTRICAL COMPONENTS	1-6

IDENTIFICATION OF THE SCOOTER

GEN/
INFO

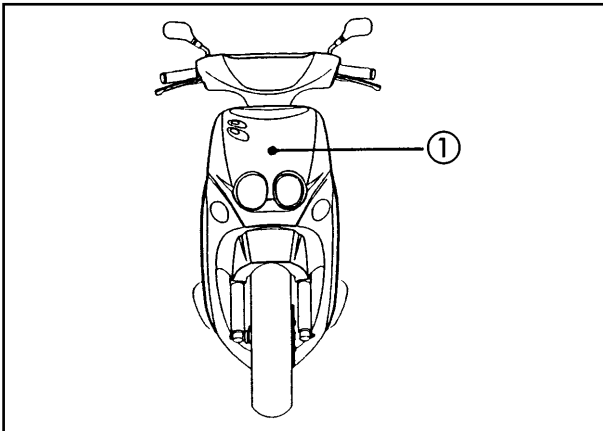

GENERAL INFORMATION SCOOTER IDENTIFICATION

FRAME SERIAL NUMBER

The serial number of the frame ① is stamped on the steering head pipe.

Frame VTL5AD according standard EU0
Frame VTL5A15 according standard EU1
Frame VTL5A19 according Mofa Version

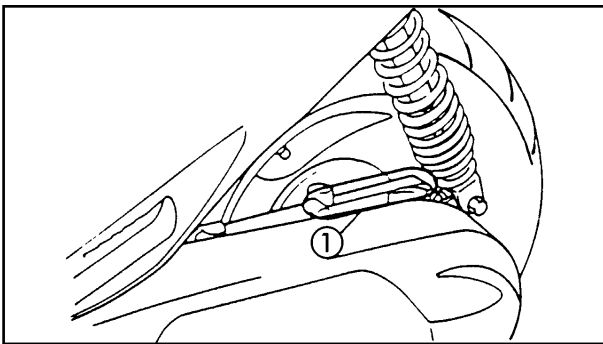

ENGINE SERIAL NUMBER

The engine serial number ① is stamped on the upper part of the rear left-hand section of the gear box.

NOTE:

The first three digits of these numbers identify the model, the remaining digits are the manufacturing number of the unit.

NOTE:

The designs and specification are subject to change without prior notice.

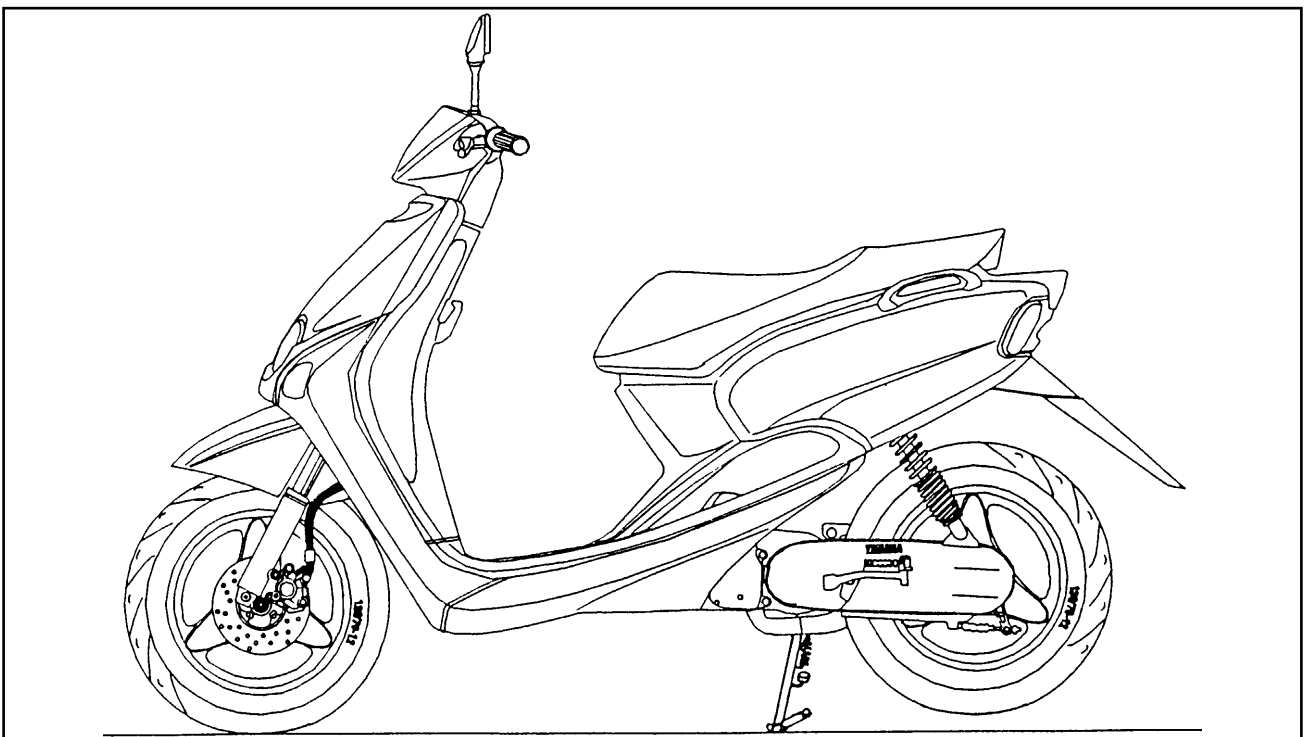

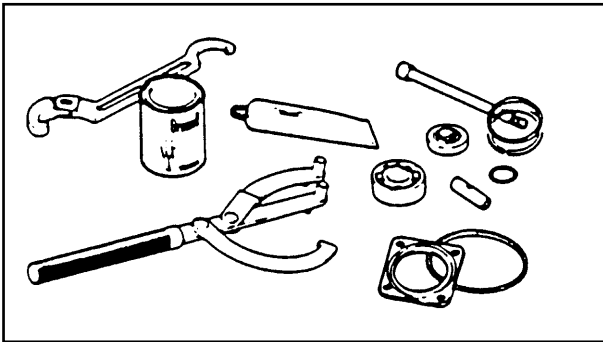

IMPORTANT INFORMATION

CHANGE OF ALL PARTS

1. We recommend that original Yamaha parts are used as spare parts. Use the oil and/or grease recommended by Yamaha for assembly and adjustment.

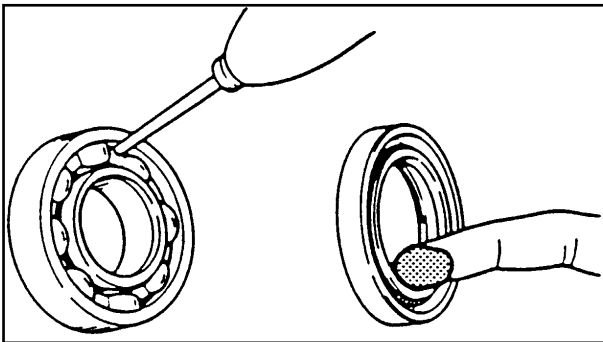

GASKETS, OIL SEALS AND O-RINGS

1. All gaskets and o-rings should be replaced when the engine is overhauled and repaired. All gasket surfaces, the lips of seals and o-rings should be cleaned.
2. Lubricate with grease all corresponding parts and bearings during assembly. Apply grease on the lips of seals.

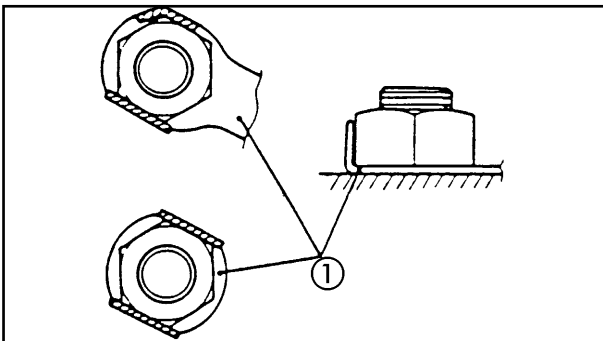

SEALING WASHER/PLATES AND KEYS

1. All washers/plates ① and keys should be replaced when they are removed. The locking tabs should be folded along the flat parts of the bolts or nuts after correctly tightening them.

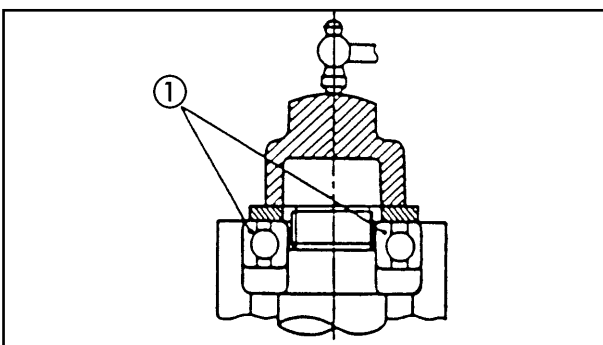

BEARINGS AND OIL SEALS

1. Install the bearings ① and oil seals ② with their manufacturer's marks or numbers facing outwards (i.e. the printed letters should be on the side exposed to view). When the oil seals are installed, apply a thin layer of light lithium-based grease on the edges of the seal. Put oil on the bearings when they are installed.

ATTENTION:

Do not turn the bearings in compressed air to dry them. This will damage the surface of the bearings.

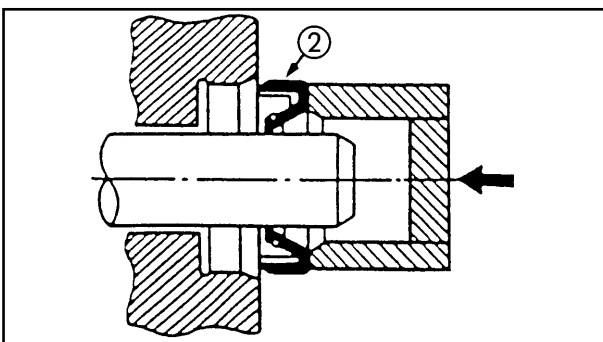

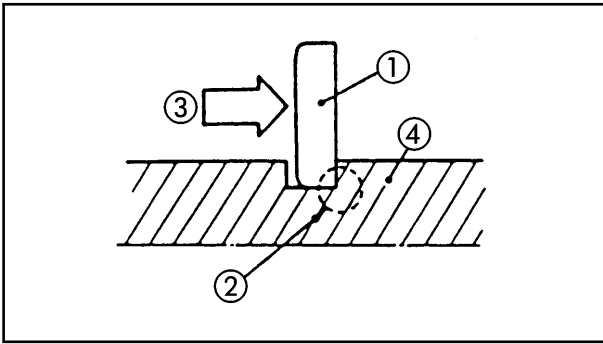

CIRCLIPS

1. All circlips should be carefully inspected before assembly. Always replace circlips of the piston drum after use. Replace deformed circlips. When installing a circlip ①, ensure that the corner with the sharp edge ② is placed in the opposing direction to the thrust ③ it receives. See sectional view. ④ Axle

SPECIAL TOOLS

Appropriate special tools are needed to complete and perfect assembly with accuracy. Using correct tools will help to avoid damage caused by the use of incorrect tools or improvised techniques.

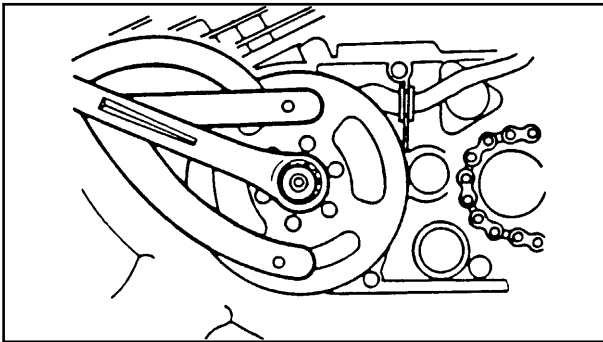

FOR SERVICING THE ENGINE

1. Engine wheel holding tool (90890-01235)

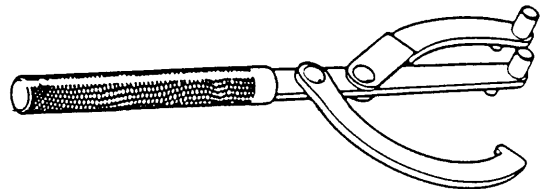

2. Engine wheel removal tool (90890-01362)

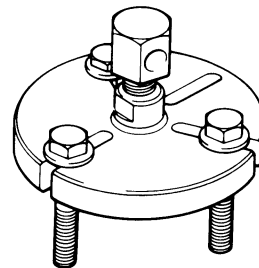

3. Crankcase separation tool (90890-01135)

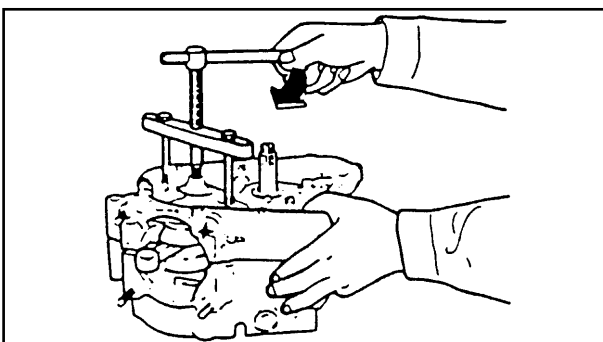
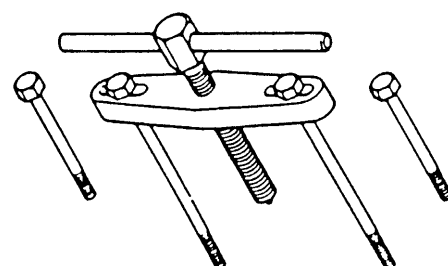

SPECIAL TOOLS

GEN/
INFO

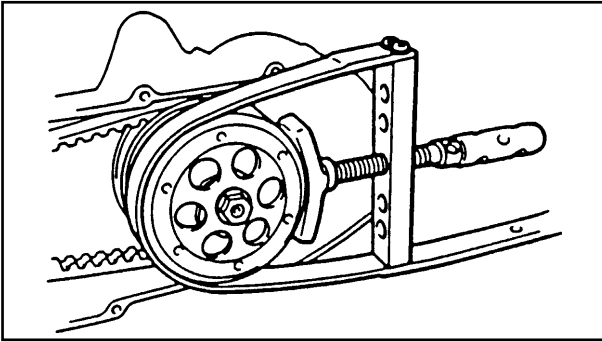

4. Pulley wheel clamp
(90890-01701)

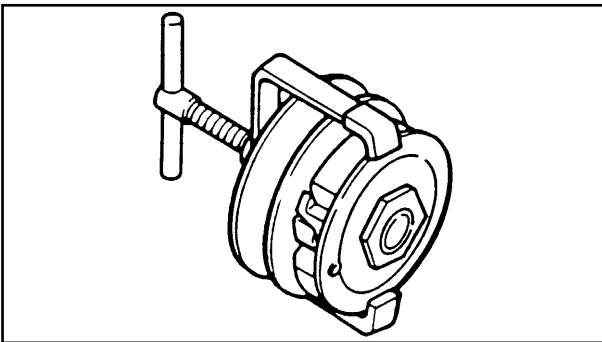
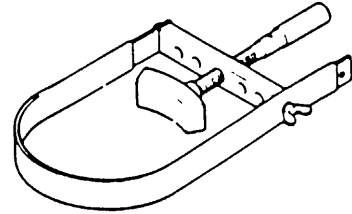

5. Clutch spring compressor
(90890-01337)

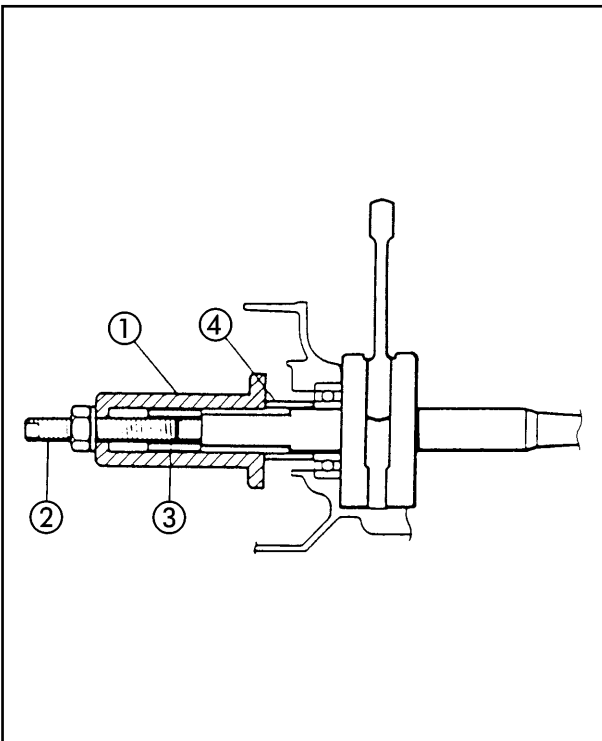
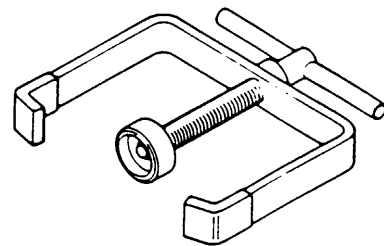

6. Crankshaft installer crucible... ①
(90890-01274)

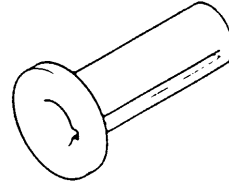

7. Crankshaft installer bolt... ②
(90890-01275)

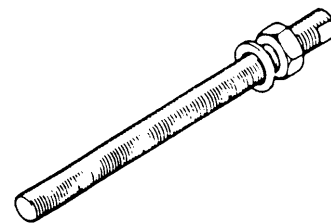

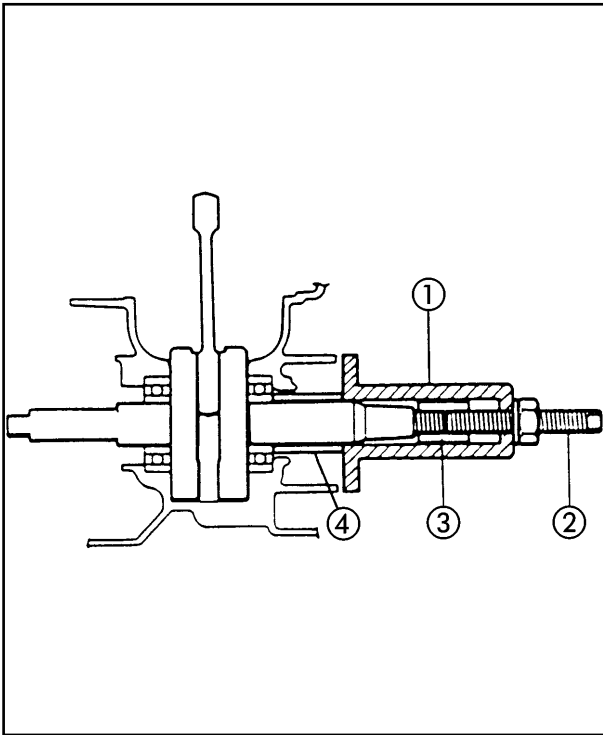

- 8. Adaptor (M10)... ③
(90890-01277)

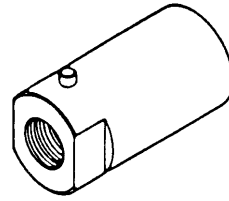

- 9. Spacer... ④
(90890-01411)

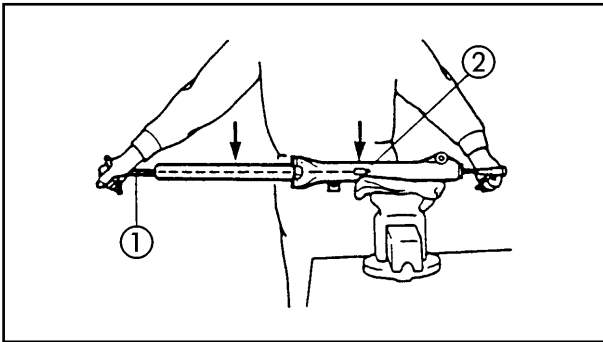
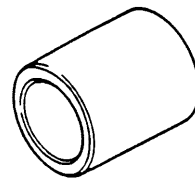

FOR SERVICING THE CHASSIS

- 1. T-shaped handle 2... ①
(90890-01326)
Shock absorber rod support... ②
(90890-01294-A)

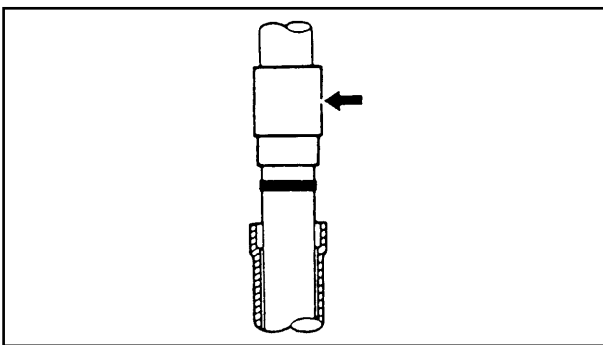
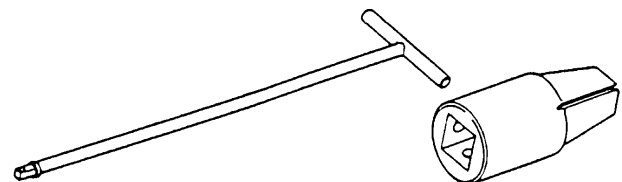

- 2. Counterbalance for insertion of fork seals
(90890-01184)

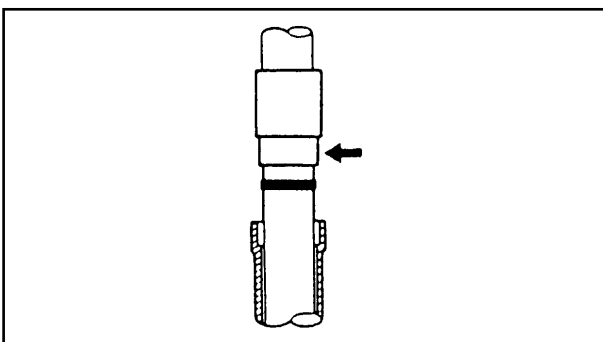
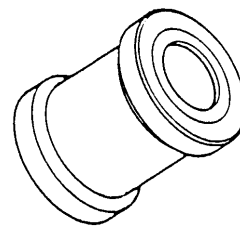

- 3. Accessory for insertion of fork seals
(90890-01186)

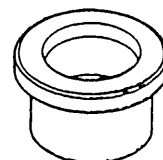

SPECIAL TOOLS

GEN/
INFO



4. Steering nuts wrench
(90890-01403)

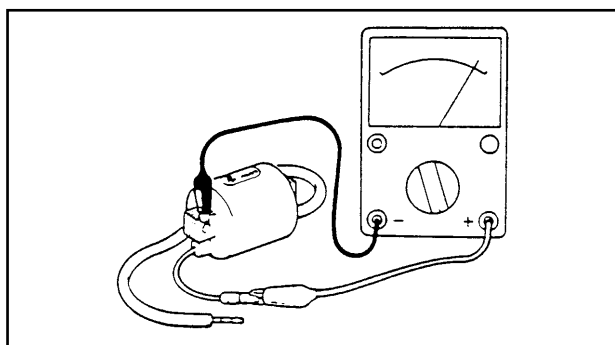
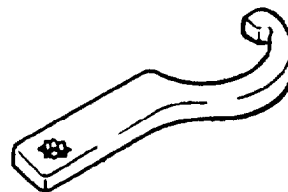

FOR ELECTRICAL COMPONENTS

1. Pocket tester
(90890-03112)

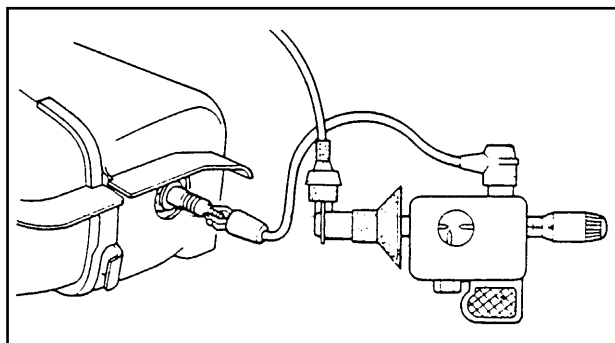
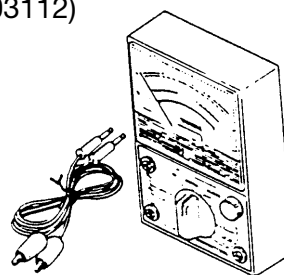

2. Ignition tester
(90890-06754)

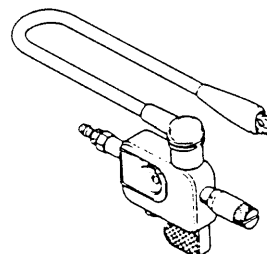

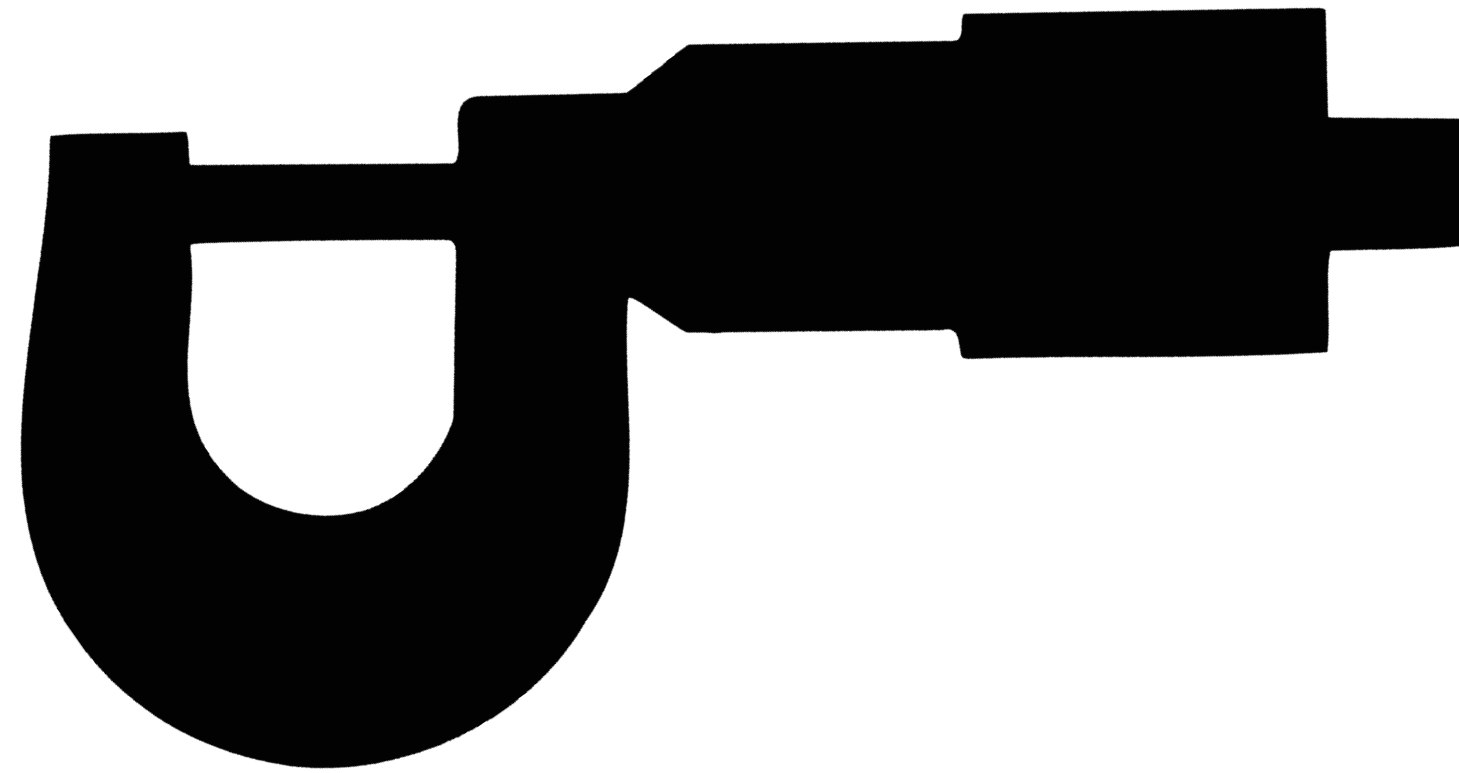

SPEC

2

CHAPTER 2 SPECIFICATIONS

GENERAL SPECIFICATIONS2-1

MAINTENANCE SPECIFICATIONS2-3

ENGINE2-3

CHASSIS2-5

ELECTRICAL SYSTEM2-6

CABLE ROUTING2-7

GENERAL SPECIFICATIONS

SPEC



Model	YN50R		
Engine: Engine type Arrangement of cylinders Cylinder capacity Diameter and stroke Compression ratio Starter system	Reed valve, petrol, 2-stroke, air-cooled One cylinder inclined to the front 49.2 cc 40.0 x 39.2 mm 11.6:1 5AD 10.2:1 SA15 11:1 SA19 Electrical and pedal kickstart		
Lubrication system: Type or grade of oil: Engine oil Transmission oil	Yamaha autolubrication 2-stroke air-cooled engine oil SE type 10W30 SAE engine oil		
Oil capacity: Oil sump (engine oil) Transmission oil Periodic change of oil Total quantity	1.2 L 0.10 L 0.11 L		
Air filter:	Flue type		
Fuel: Type Fuel tank capacity	Unleaded petrol 6.5 L		
Carburettor: Type/Manufacturer	PHVA/DELLORTO/PY12,1/GURTNER		
Spark plug: Type/Manufacturer Distance between electrodes	5AD y SA15 BR8HS/N.G.K. 0.6 ~ 0,7 mm	SA19 BPR4HS/NGK 0.6 ~ 0.7 mm	
Clutch type:	Dry, automatic centrifugal		
Transmission: Primary reduction system Primary reduction ratio Secondary reduction system Secondary reduction ratio Type of transmission Action	Helicoidal gearing 52/13 (4.00) Straight gearing 42/13(3.230) 5AD-SA15 45/12(33.750) SA19 Automatic one speed (Trapezoidal belt type) Automatic centrifuge type		
Chassis: Frame Inclination angle of front axle Trail	Steel underside of pipe 26,5° 92.5 mm		
Tyres: Size (FR) Size (R)	120/70-12 130/70-12		
Tyre pressures (cold): <div style="text-align: right;"> (Front) (Rear) </div>	1.75 kg/cm ² 2.00 kg/cm ²		

GENERAL SPECIFICATIONS

SPEC



Model	YN50R
Brakes: Front brake type Operation Rear brake type Operation	Disc brake Right-hand operation Drum brake Left-hand operation
Suspension: Front suspension Rear suspension	Telescopic fork Balancing unit
Shock absorber: Front shock absorber Rear shock absorber	Spring/oil shock absorber Spring/oil shock absorber
Travel of wheels: Travel of front wheel Travel of rear wheel	70 mm 60 mm
Electrical system: Ignition system Generating system Battery type or model Battery capacity	DC-C.D.I. Magnetic flywheel YB4C-B 12V4AH
Type of headlight:	Bulb type
Bulb voltage/quantity: Headlamp Rear light/brake Indicator Metre light	25W/25Wx2 5/21W 10Wx4 1.2Wx2
Warning lights/quantity: Oil Fuel Indicators	2Wx1 2Wx1 2Wx2



MAINTENANCE SPECIFICATIONS

ENGINE

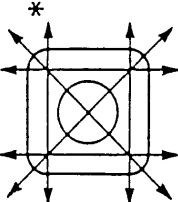
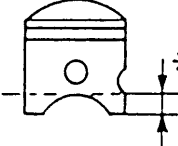
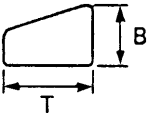
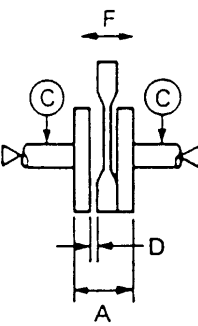
Model	YN50R
Cylinder head: Warping limit	 0.02 mm * The lines indicate the measurement
Cylinder: Internal diameter <Limit> Taper limit Eccentricity limit	39.993 ~ 40.012 mm <40.1 mm> 0.05 mm 0.01 mm
Piston: Piston size Measurement point Piston clearance First clearance	 39.952 ~ 39.972 mm 5 mm 0.034 ~ 0.047 mm 40.50 mm
Piston ring: Cross section B x T Distance between ends (installed) <Limit> Lateral clearance	 1.5 x 1.8 mm 0.15 ~ 0.35 mm <0.6 mm> 0.03 ~ 0.05 mm
Crank shaft: Width of crank shaft "A" Deflection limit "C" Connecting rod big end clearance "D" Free play from small end "F" Free play "E"	 37.90 ~ 37.95 mm 0.03 mm 0.2 ~ 0.5 mm 0.4 ~ 0.8 mm 0.004 ~ 0.017 mm

MAINTENANCE SPECIFICATIONS

SPEC



Model	YN50R					
Automatic centrifugal clutch: Thickness of clutch shoe <Limit> Free length of clutch shoe spring Clutch revolutions Clutch binding revolutions	2 mm <1 mm> 29.9 mm 3.600±250 rpm 5.600±400 rpm					
Transmission: Main axle deflection limit Drive axle deflection limit	0.08 mm 0.08 mm					
Choke handle: Type Pedal friction force	Ratchet type 150 ~ 250 g					
Air filter oil grade (oil filter):	Oil for foam air filter 2T oil for air-cooled engines					
Carburettor: Type/Manufacturer/Quantity Main jet (M.J.) Retaining position of jet needles (J.N.) Main air jet (M.A.I.) Pilot jet (P.J.) Pilot air screw (P.A.S.) Valve seat size engine idling	PHVA/Dellorto/1		YP12/GURTNER/1			
		#78/5AD	#65//SA15	#74/5AD	#62/SA15	#60/SA19
	A12-3/5	A20-3/5	B10A-2/3	B10A-2/3	L3035H-1/3	
	ø 1.5	ø 1.5	-	-	-	
	#36/5AD	#36/SA15	#38/5AD	#38/SA15	#36/SA19	
	$1 \frac{1}{4} \pm \frac{1}{4}$	$2 \frac{1}{8} \pm \frac{1}{8}$	$1 \frac{1}{8}$	$1 \frac{7}{8}$	$1 \frac{7}{8}$	
	1.2	1.800 r.p.m.		1.4		

CHASSIS

Model	YN50R
Steering system: Steering bearing type	Ball bearing
Front suspension: Travel of front shock absorber Free length of shock absorber spring <Limit> Spring/stroke ratio (K ₁) (K ₂) Oil capacity Oil grade	70 mm 226 mm 1.12 Kgf/mm 1.78 Kgf/mm 45 cm ³ ±1 10 W shock absorber oil or equivalent
Rear suspension: Shock absorber travel Length of spring coupling Spring/stroke ratio (K ₁) (K ₂)	60 mm 221 mm 3.75 Kgf/mm 7,10 Kgf/mm
Wheels: Type of front wheel Type of rear wheel Size/material of front wheel Size/material of rear wheel Rim run-out limit Vertical Lateral	Alloy rim Alloy rim 12 x 3.5 aluminium 12 x 3.5 aluminium 1.0 mm 1.0 mm
Front disc brake Type External diameter and disc thickness Thickness of pads <Limit> Internal diameter of master cylinder Internal diameter of calliper Brake fluid type	Single 190.0 x 3.5 mm 4 mm <0.8 mm 11 mm 30.16 mm DOT 4
Drum brake: Type Internal diameter of drum <Limit> Lining thickness <Limit>	Shoes 110 mm 110.5 mm 4.0 mm 2.0 mm
Brake levers Free play of brake lever (right)/position Free play of brake lever (left)/position	2 ~ 5 mm /at the end of the lever 5 ~ 10 mm /at the end of the lever



ELECTRICAL SYSTEM

Model	YN50R
Ignition system: Type Ignition distribution (A.P.M.S.)	DC-C.D.I. 14*/5.000 r/min
C.D.I.: Harnessing coil resistance (colour)	400 ~ 600 Ω a 20 °C (68 °F) (Black/Red-Black)
Ignition coil: Spark plug electrodes gap Primary coil resistance Secondary coil resistance	6.0 mm 0.56 ~ 0.84 Ω at 20 °C 5,68 ~ 8,52 KΩ at 20 °C
Charging system: Charging output Charging coil resistance (colour) (Black-White)	0.4 A or more/3.000 rpm/min 1 A or less/8.000 rpm/min 4.8 ~ 7.2 Ω a 20 °C (68 °F)
Lighting system: Lighting output Lighting coil resistance (colour)	12 V or more/3.000 rpm/min, 15 V or less/8.000 rpm/min 0.4 ~ 0.6 Ω a 20 °C (68 °F) (Yellow/Red-Black)
Battery: Type: Capacity Specific gravity	YB4L-B 12V4AH 1280/20 °C
Starter system: Type:	Constant mesh type
Starter motor: Output Induction coil resistance Brush length <Limit>	0.14 kw 0.064 ~ 0.079 Ω at 20 °C 3.9 mm <0.9 mm>
Circuit breaker: Type: Amperage/Quantity Principal	Fuse 7A x 1



CABLE ROUTING

- ① Front brake pipe
- ② Rear brake cable
- ③ Rear brake calliper
- ④ Rear mudguard
- ⑤ Rear warning light
- ⑥ Vacuum tube
- ⑦ Fuel pipe
- ⑧ Speedometer cable
- ⑨ Installation
- ⑩ Breather
- ⑪ Accelerator cable
- ⑫ Seat closing cable
- ⑬ Oil hose
- ⑭ choke wire

- A Insert the seat closing cable through the frame orifice
- B Connect the oil tube to the carburettor
- C Splice the fuel pipe to the cock
- D Splice the fuel pipe to the carburettor
- E Press the earth cable and the starter motor together
- F Splice all the cables except the brake hose, without tightening
- G Splice to the frame wire harness and throttle
- H Pass the brake cable through the guide

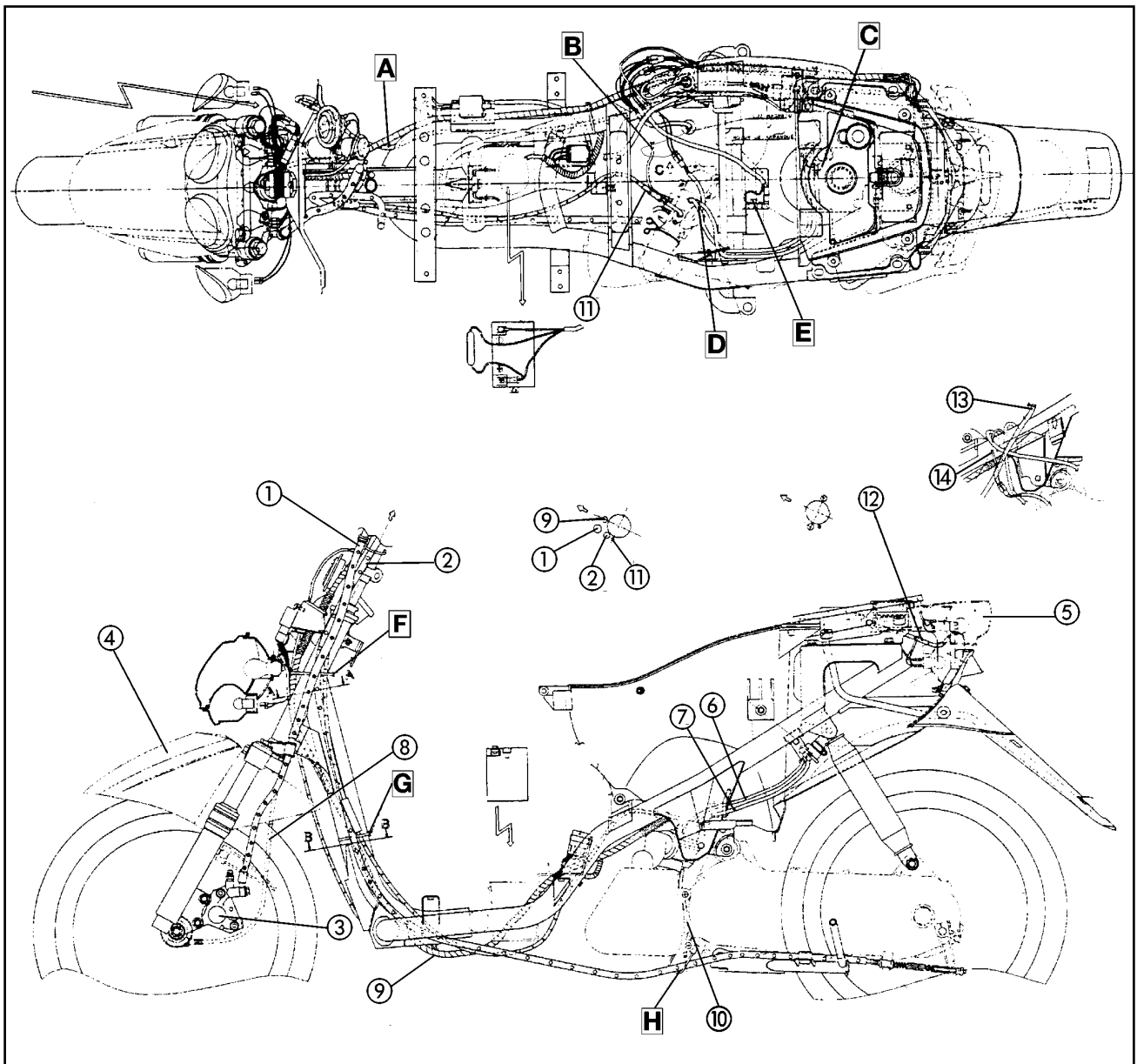



- ① Rectifier/Regulator
- ② Main switch
- ③ Fuel level measurer
- ④ Horn
- ⑤ Ignition coil
- ⑥ Spark plug cable
- ⑦ Oil level sensor
- ⑧ Oil tank
- ⑨ C.D.I.

- A Splice the electrical installation to the frame
- B Splice the oil pipe to the tank
- C Connect the oil pipe to the pump
- D Splice the installation to the frame
- E Tighten the earth cable and the ignition coil together
- F Pass the speedometer cable through the guide
- G Fit the grommet in the small hole of the underbracket

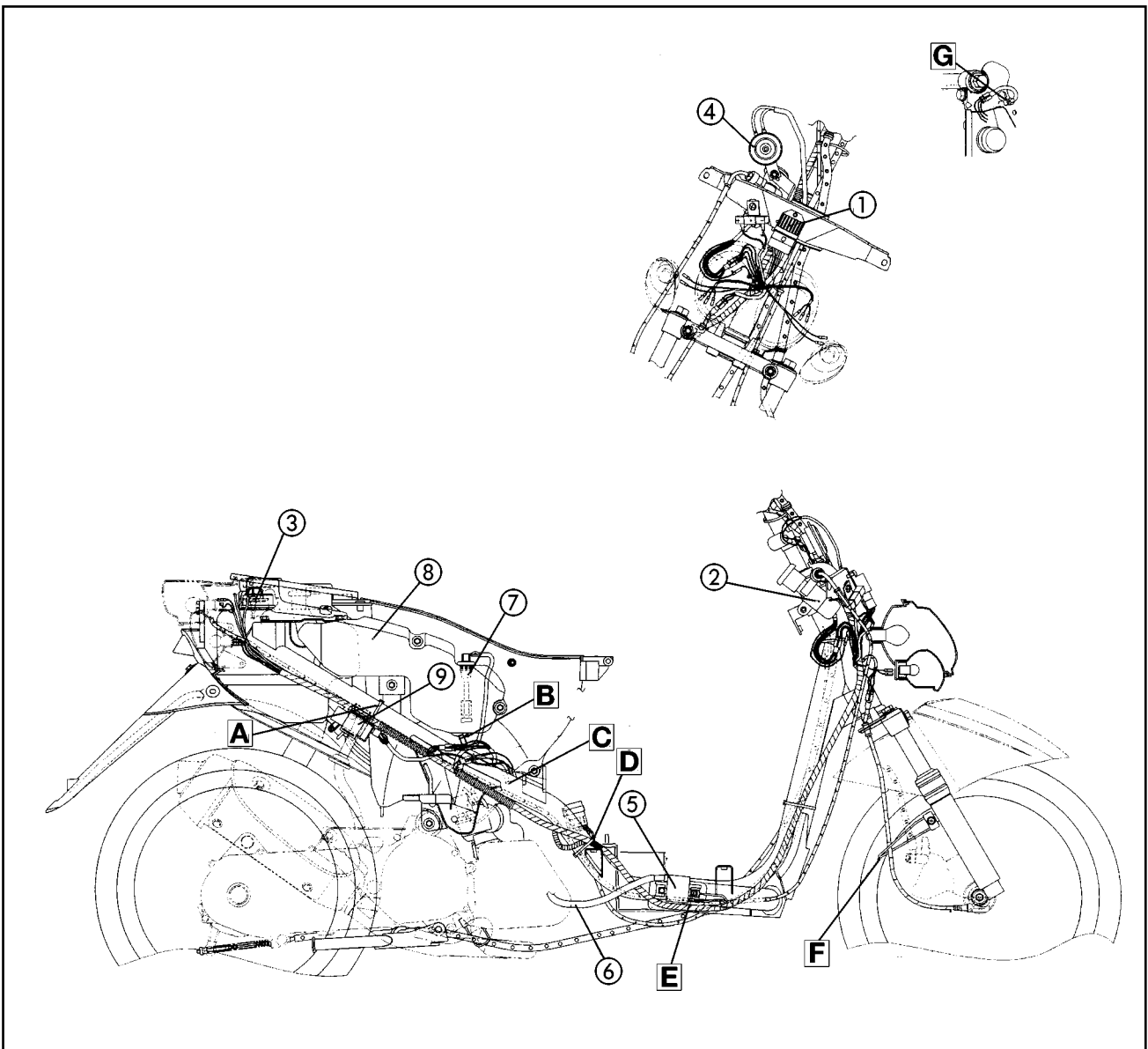



- ① Front break switch
- ② Electrical installation
- ③ Intermittent relay
- ④ Speedometer assembly
- ⑤ Accelerator cable
- ⑥ Rear brake cable
- ⑦ Choke cable
- ⑧ Front brake hose

- A Do not pinch the accelerator cable when assembling the handlebar covers
- B Accelerator cable tensioner. Cover after adjusting
- C Connect the brake switch cables in this area
- D Do not pass the brake pipe through the flange

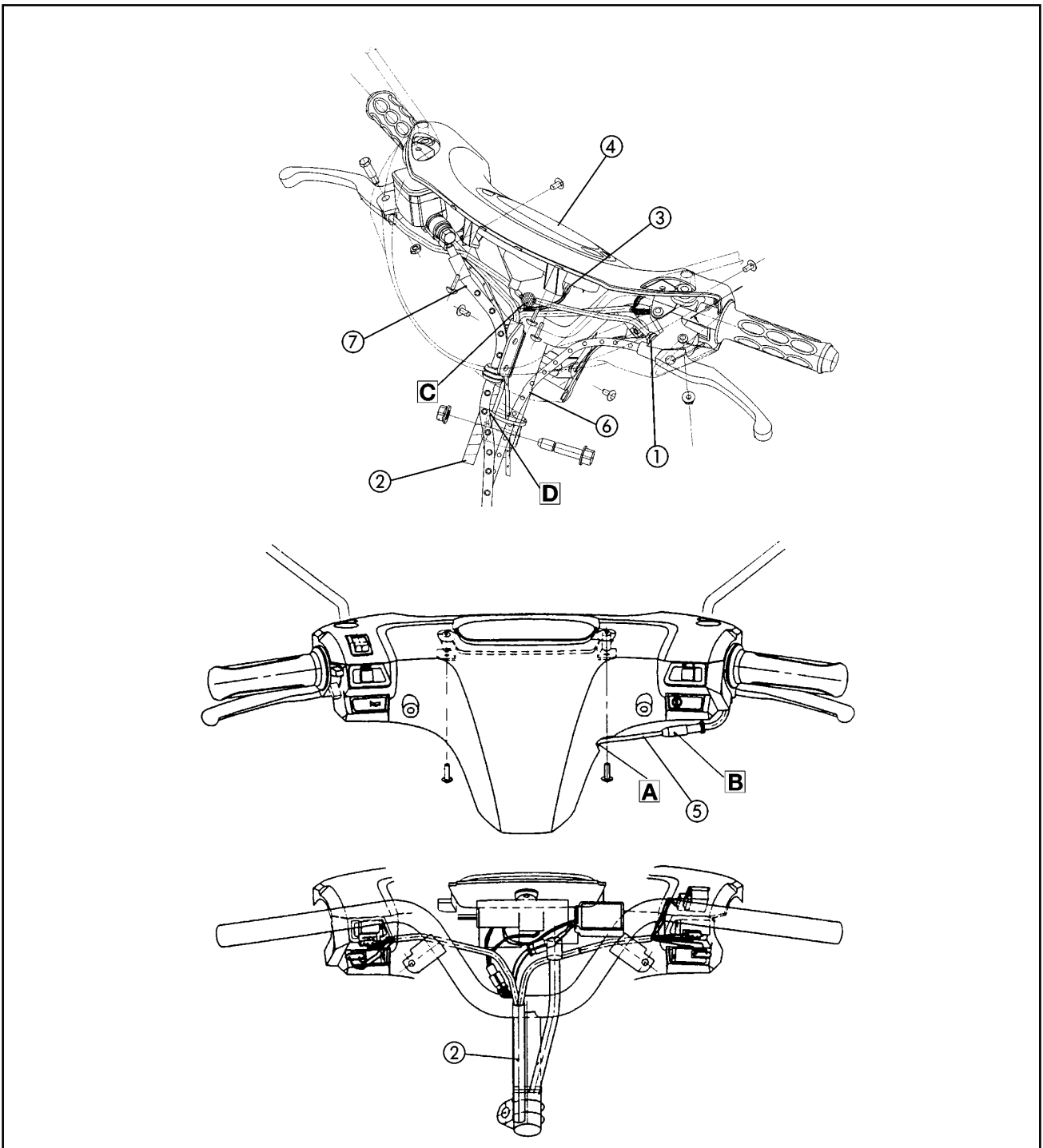



INSP



ADJ

3



CHAPTER 3 PERIODIC INSPECTION AND ADJUSTMENTS

INTRODUCTION/PERIODIC MAINTENANCE/LUBRICATION INTERVALS	...3-1
REAR BODYWORK AND FOOTREST	3-2
REMOVAL	3-2
INSTALLATION	3-3
MUDGUARDS, LOWER COVER AND FRONT PANEL	3-4
REMOVAL	3-5
INSTALLATION	3-5
HANDLEBAR COVERS	3-5
REMOVAL	3-5
INSTALLATION	3-5
ENGINE	3-6
ADJUSTMENT OF ENGINE IDLING	3-6
ADJUSTMENT OF FREE PLAY OF TROTTLE CABLE	3-7
SPARK PLUG INSPECTION	3-8
INSPECTION OF ENGINE OIL LEVEL	3-9
CHANGE OF TRANSMISSION OIL	3-10
AUTOLUBE PUMP AIR BLEEDING	3-10
CLEANING AIR FILTER	3-10
CHASSIS	3-12
ADJUSTMENT OF FREE PLAY OF FRONT BRAKE LEVER	3-12
ADJUSTMENT OF FREE PLAY OF REAR BRAKE LEVER	3-12
INSPECTION OF BRAKE PADS	3-12
INSPECTION OF BRAKE SHOES	3-13
INSPECTION OF BRAKE FLUID LEVEL	3-13
AIR BLEEDING (HYDRAULIC BRAKE SYSTEM)	3-14
STEERING ADJUSTMENT	3-14
INSPECTION OF TYRES	3-15
WHEEL INSPECTION	3-16
INSPECTION OF REAR FORK	3-16
REAR SHOCK ABSORBER INSPECTION	3-16
ELECTRICAL SYSTEM	3-17
INSPECTION OF BATTERY	3-17
INSPECTION OF FUSES	3-19
ADJUSTMENT OF HEADLAMP BEAM	3-20
REPLACEMENT OF HEADLAMP BULB	3-20



PERIOD INSPECTION AND ADJUSTMENTS

INTRODUCTION

This chapter includes all information necessary to carry out inspections and adjustments recommended. These preventive maintenance procedures, if they are correctly followed, will ensure the most reliable operation of the vehicle and a longer useful life. The need for overhauls and costly repairs will be greatly reduced. This applies both to vehicles which are already in service and to new vehicles which are ready for sale. All service technicians should familiarise themselves with the entire chapter.

PERIODIC MAINTENANCE / LUBRICATION INTERVALS

N.	INTEM	CHECK OR MAINTENANCE JOB	ODOMETER READING (x 1.000 km)					ANNUAL CHECK
			1	6	12	18	24	
1	*	Fuel line • Check fuel hoses and vacuum hose for cracks		✓	✓	✓	✓	✓
2		Spark Plug • Check condition. • Clean and regap. • Replace.		✓		✓		
3		Air filter element • Clean. • Replace.		✓		✓		
4	*	Front brake • Check operation, fluid level and vehicle for fluid leakage. • Replace brake pads.	✓	✓	✓	✓	✓	✓
5	*	Rear brake • Check operation and adjust brake lever freeplay. • Replace brake shoes.	✓	✓	✓	✓	✓	✓
6	*	Brake hose • Check for cracks or damage. • Replace. (See NOTE on page 6-5)		✓	✓	✓	✓	✓
7	*	Wheels • Check runout and for damage.		✓	✓	✓	✓	
8	*	Tires • Check tread depth and for damage. • Replace if necessary. • Check air pressure. • Correct if necessary.		✓	✓	✓	✓	
9	*	Wheel bearings • Check bearing for looseness or damage.		✓	✓	✓	✓	
10	*	Steering bearings • Check bearing play and steering for roughness. • Lubricate with lithium-soap-based grease.	✓	✓	✓	✓	✓	
11	*	Chassis fasteners • Make sure that all nuts, bolts and screws are properly tightened.		✓	✓	✓	✓	✓
12		Centerstand • Check operation. • Lubricate.		✓	✓	✓	✓	✓
13	*	Front fork • Check operation and for oil leakage.		✓	✓	✓	✓	
14	*	Rear shock absorber assembly • Check operation and shock absorber for oil leakage.		✓	✓	✓	✓	
15	*	Carburetor • Check starter (choke) operation. • Adjust engine idling speed.	✓	✓	✓	✓	✓	✓
16	*	Autolube pump • Check operation. • Bleed if necessary.	✓		✓		✓	✓
17		Final gear oil • Check oil level and vehicle for oil leakage. • Change.	✓	✓		✓	✓	
18	*	V-belt • Replace			✓		✓	
19		Front and rear brake switches • Check operation.	✓	✓	✓	✓	✓	✓
20	*	Moving parts • Lubricate. and cables		✓	✓	✓	✓	✓
21		Lights, signals and switches • Check operation. • Adjust headlight beam.	✓	✓	✓	✓	✓	✓

- Since these items require special tools, data and technical skills, have a Yamaha/MBK dealer perform the service.

NOTE:

- The air filter needs more frequent service if you are riding in unusually wet or dusty areas.
- Hydraulic brake service
- Regularly check and, if necessary, correct the brake fluid level.
- Every two years replace the internal components of the brake master cylinder and caliper, and change the brake fluid.
- Replace the brake hoses every four years and if cracked or damaged.

REAR BODYWORK AND FOOTREST

INSP
ADJ

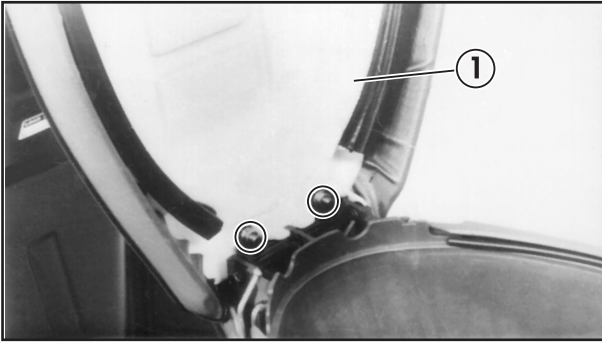

REAR BODYWORK AND FOOTREST

REMOVAL

1. Raise the seat
2. Remove:
 - Seat ①

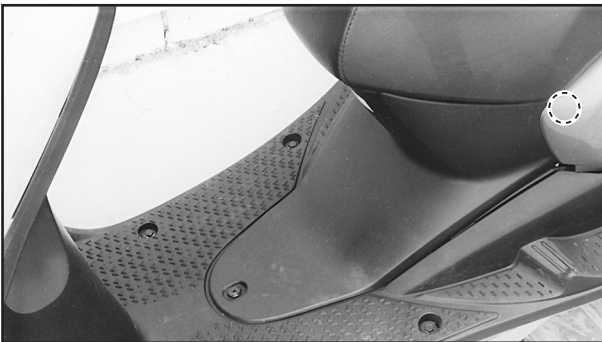

3. Remove:
 - Battery cover

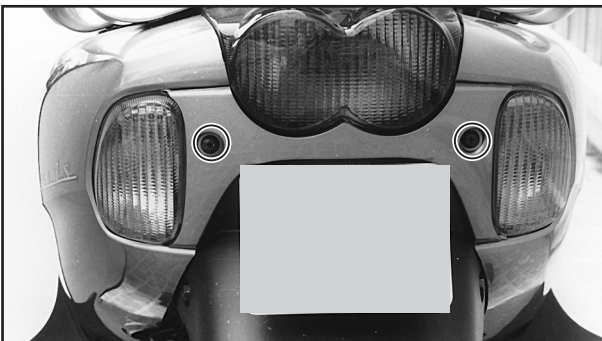

4. Remove:
 - Rear cover



5. Remove:
 - Side covers

NOTE:

When the side covers are being removed unhook them from the catches and slide them outwards.

REAR BODYWORK AND FOOTREST

INSP
ADJ

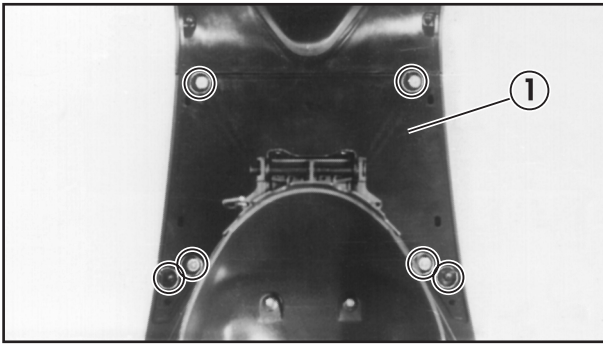

6. Remove:
- Footrest ①

INSTALLATION

When the foot support panel and the rear cover are being installed, reverse the removal process.

Remember the following points.



1. Install:
- Side covers

NOTE:

- Match up the support and hole and then apply pressure.



REAR BODYWORK, MUDGUARDS

REMOVAL

1. Remove:
 - Main switch cover.
Turn the cover to the left and pull upwards.
2. Remove:
 - Upper screws in ignition key panel
 - Rear fairing assembly and headlight

NOTE:

Disconnect the headlight cable and indicators.

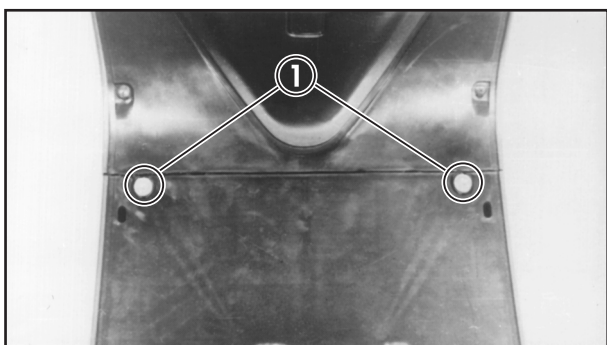

3. Remove:
 - Front lower fairing screws ①
 - Carrier hook bolt
 - Footrest lower cover screws
4. Remove:
 - Battery cover
 - Battery, fuse and starter relay
 - Bottom footrest cover
 - Footrest
 - Bottom rear fairing

NOTE:

Disconnect indicator cables.

- Mudguards

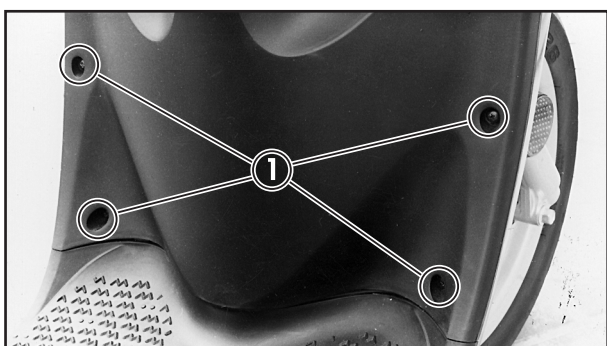

INSTALLATION

Reverse the removal process.

NOTE:

After installing all plastic parts, check that all hooks are properly attached.

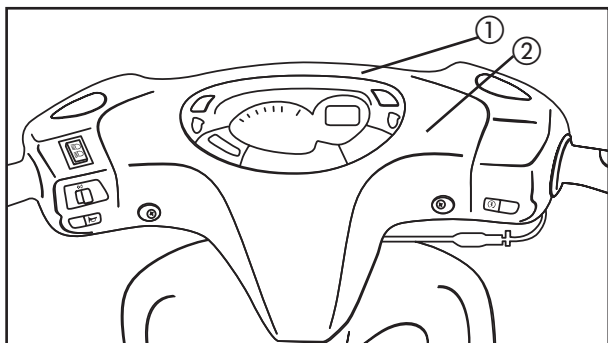

HANDLEBAR COVERS

REMOVAL

1. Remove:
 - Front handlebar cover ①
 - Rear handlebar cover ②

INSTALLATION

Reverse the removal procedure. Remember the following points.

1. Install:
 - Front handlebar cover ①
 - Rear handlebar cover ②

NOTE: _____

When installing the rear cover, check that the speedometer cables goes through its housing.

NOTE: _____

After installing the handlebar cover, ensure that all the hooks are properly coupled.

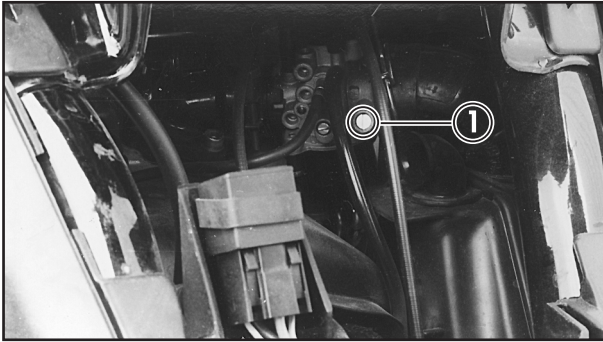

ENGINE

ADJUSTMENT OF ENGINE IDLING

1. Tighten:
 - Pilot air screw ①
Turn the pilot air screw inwards until it seats itself lightly.
2. Loosen:
 - Pilot air screw.
Unscrew it from its lightly seated position.

OUTWARDS TURNS OF THE PILOT AIR SCREW:

DELLORTO		GURTNER		
EU0	EU1	EU0	EU1	MOFA
1 1/2 ± 1/4	2 1/8 ± 1/8	1 1/8	1 7/8	1 7/8

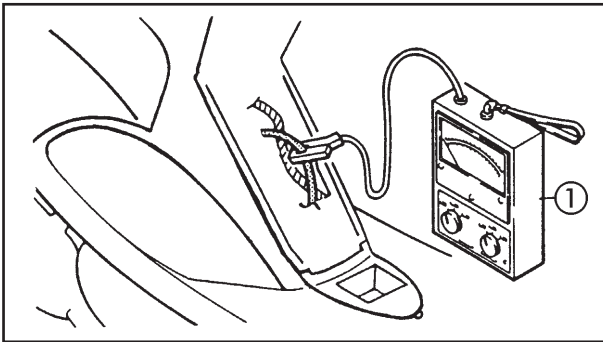

3. Start the engine and let it warm up.

⚠ WARNING

Before starting the engine, ensure that the central safety stand is being used.

4. Join:
 - Inductive tachometer ①
On the spark plug cable

	Inductive tachometer 90890-03113
---	--

5. Check:
 - Engine idling.
Outside specified value → Adjust.

	Engine idling 1.800 rpm
---	-----------------------------------

6. Adjust:
 - Engine idling



Adjustment steps:

- Turn the accelerator stop screw ① outward or inwards until the specified idling is obtained.

Turn inwards → Increases idling.
Turn outwards → Decreases idling.

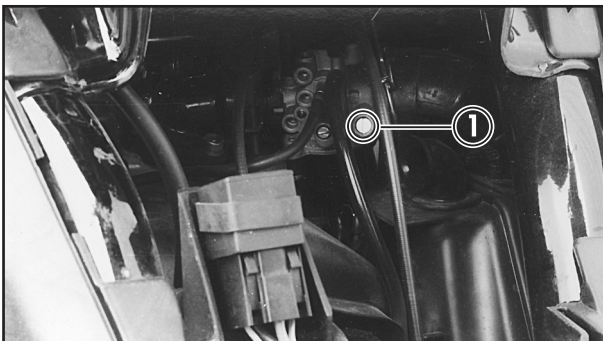

AJUSTE DEL JUEGO LIBRE DEL CABLE DEL ACELERADOR

INSP
ADJ

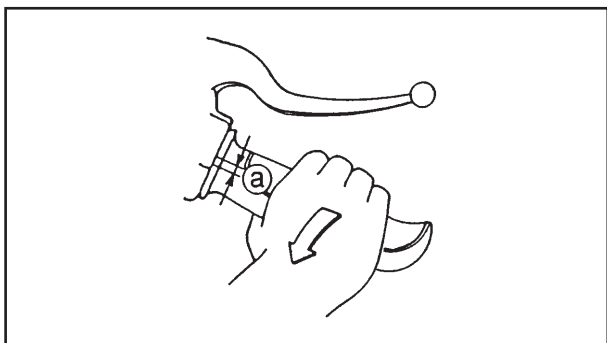

ADJUSTMENT OF FREE PLAY OF THROTTLE CABLE

1. Check:
 - Free play of throttle cable (a)
Outside specified value → Adjust.



Free play
2 ~ 5 mm

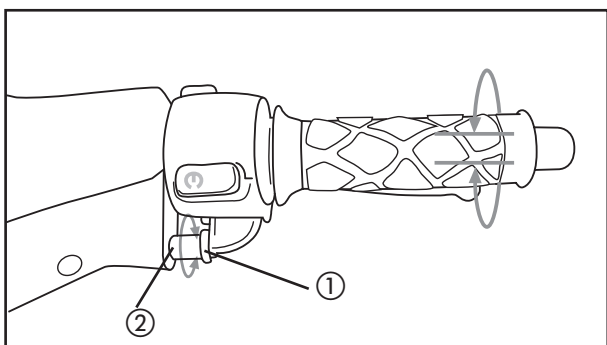

Steps for adjusting the free play of the throttle cable:

NOTE:

Before adjusting the free play of the throttle, engine idling should be adjusted.

First step:

- Loosen the lock nut (1) of the throttle cable.
- Turn the adjuster (2) inwards or outwards until the specified free play is obtained.

Turn inwards → Free play increases.
Turn outwards → Free play decreases.

- Tighten the lock nuts.

NOTE:

If the free play cannot be adjusted, adjust the cable on the side of the carburettor (second step).

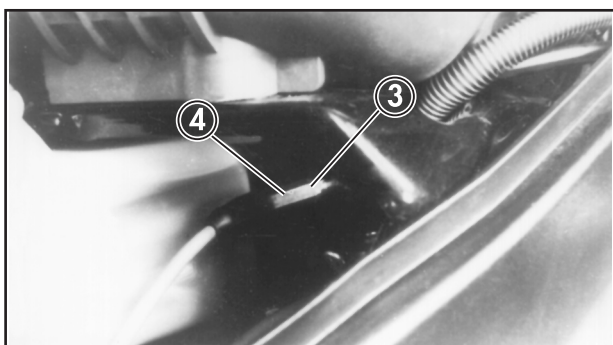

Second step:

- Remove the cover.
- Loosen the lock nut (3).
- Turn the adjuster (4) inwards or outwards until the specified free play is obtained.

Turn inwards → Free play increases.
Turn outwards → Free play decreases.

- Tighten the lock nut.
- Install the cover.

⚠ WARNING

After adjustment, turn the handlebar to the right and left and check that the idling does not vary.

SPARK PLUG INSPECTION

INSP
ADJ

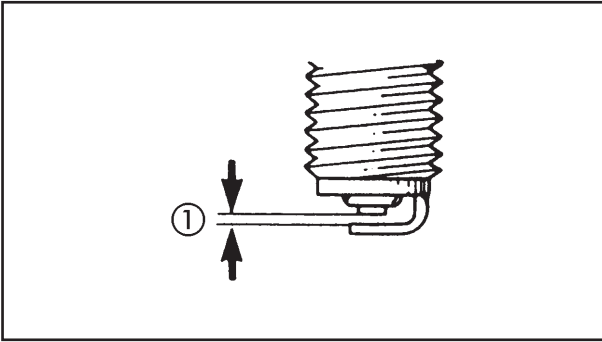

SPARK PLUG INSPECTION

1. Inspect:
 - Incorrect type of spark plug → Replace

**Standard spark plug (5AD y SA15)
BR8HS/N.G.K.
for SA19
BRP4HS/N.G.K.**

2. Inspect:
 - Electrode ①
Worn/Damaged → Replace
 - Insulator ②
Abnormal colour → Replace
The normal colour is a light to medium coffee colour.
3. Clean the spark plug with a spark plug cleaner or wire brush.
4. Measure:
 - Distance between electrodes
Use a thickness gauge.
Outside the specified value → Correct



**Gap between electrodes
0.6 ~ 0.7 mm**

5. Tighten:
 - Spark plug



**Spark plug
2.0 m • kg**

INSPECTION OF ENGINE OIL LEVEL

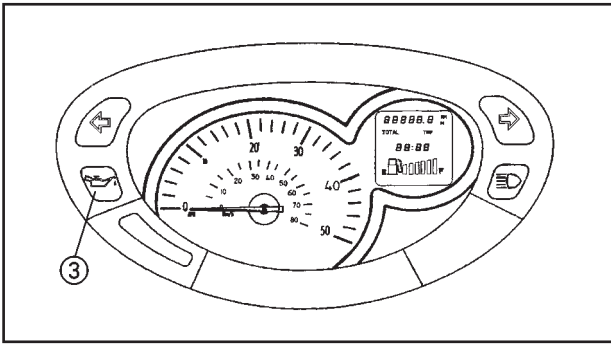



INSPECTION OF ENGINE OIL LEVEL

- Inspect:
 - Engine oil level
 - Low oil level → Add sufficient oil.

③ Oil indicator light “OIL CAUTION”

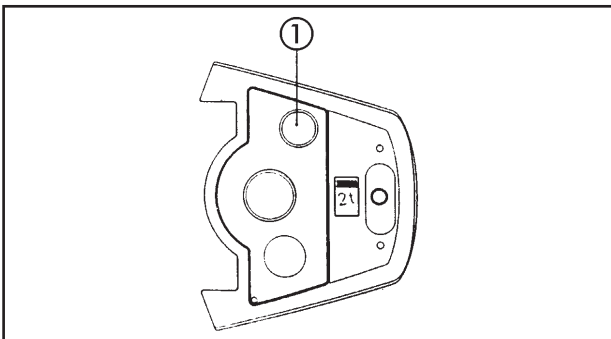
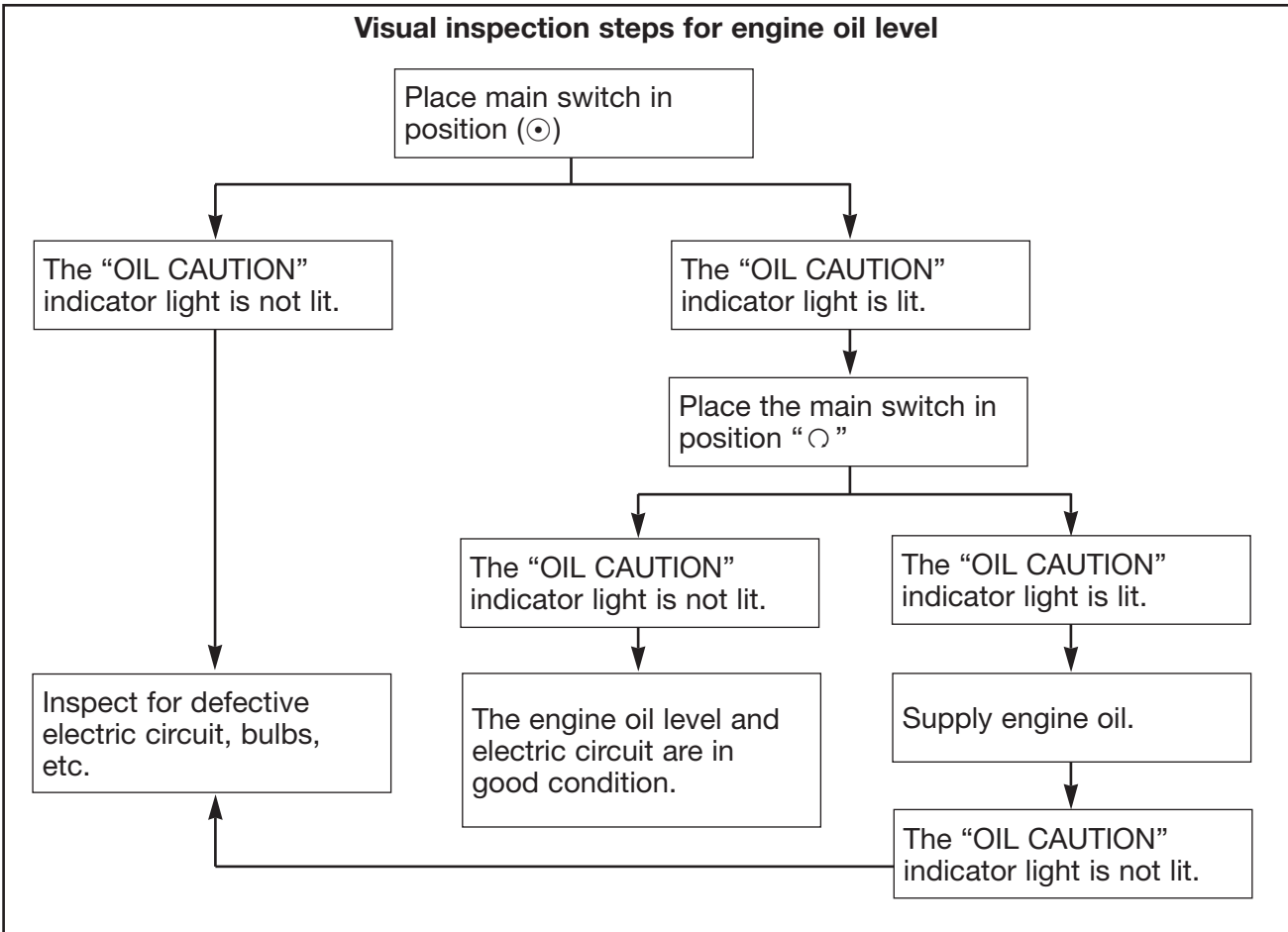
Visual inspection steps for engine oil level



 **Recommended oil:**
JASO grade FC 2 stroke engine oil or equivalent
Total:
1.2 L

NOTE: _____
 After filling the oil tank, replace the cap and close the seat.

CHANGE OF TRANSMISSION OIL / CLEANING AIR FILTER

INSP
ADJ

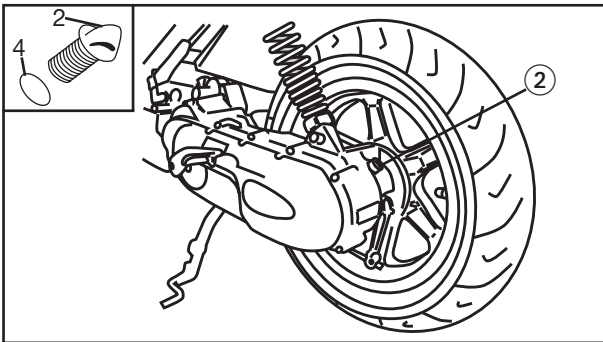
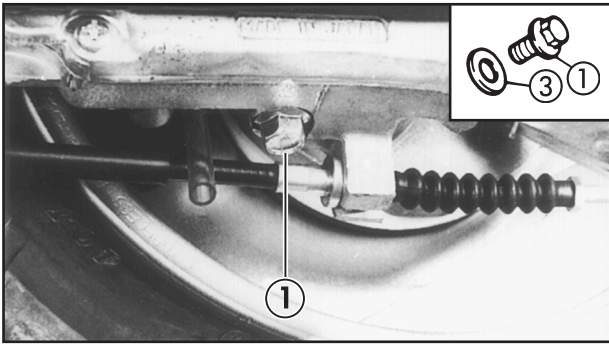

CHANGE OF TRANSMISSION OIL

1. Remove:
 - Drainage bolt ①
Drain the transmission oil.
 - Oil refill cap ②
2. Inspect:
 - Gasket ③ (drainage screw)
 - O-ring ④ (refill cap)
Damaged → Change
3. Install:
 - Gasket
 - Drainage screw



Drainage screw
18 Nm (1.8 m • kg)

4. Fill:
 - Transmission Case



Transmission oil
SE engine oil type SAE 30 or GL
gear oil
Capacity:
0.11 L

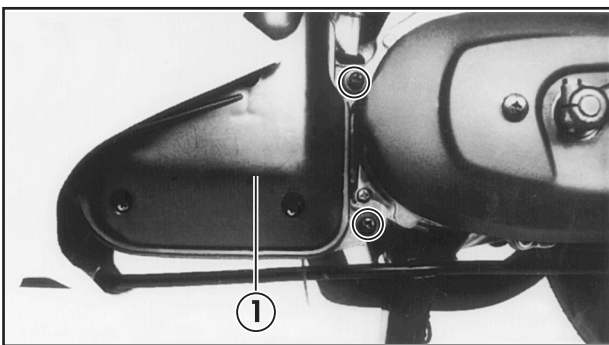

CLEANING AIR FILTER

Carburettor side

1. Remove:
 - Air filter box assembly ①

INSPECTION OF BRAKE SHOES / INSPECTION OF BRAKE FLUID LEVEL

INSP
ADJ

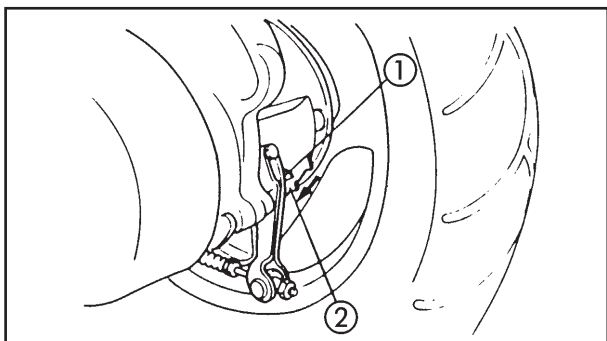

INSPECTION OF BRAKE SHOES

1. Activate the brake lever
2. Inspect:
 - Wear indicator ①Indicator on wear limit line ② → Change the brake shoes.

INSPECTION OF BRAKE FLUID LEVEL

NOTE:

Place the scooter upright when inspecting the fluid level.

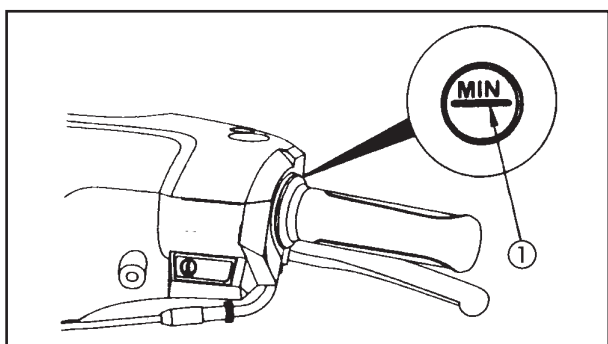

1. Inspect:
 - Fluid level.The fluid level is below the minimum level line → Refill up to correct level.



Recommended fluid:
DOT 4

ATTENTION:

The fluid may corrode painted surfaces or plastic parts. Always clean any spilt fluid immediately.

⚠ WARNING:

- Only use fluid of the designated quality. Otherwise the rubber seals may deteriorate due to leakages and poor performance of the brakes.
- Refill with the same type of fluid. The mixture of fluids may cause a damaging chemical reaction which may cause the poor performance of the brakes.
- Take care not to let water enter the pump while it is being filled. The water will lower the boiling point of the fluid significantly and may cause a steam blockage.

AIR BLEEDING (HYDRAULIC BRAKE SYSTEM) / STEERING ADJUSTMENT

INSP
ADJ

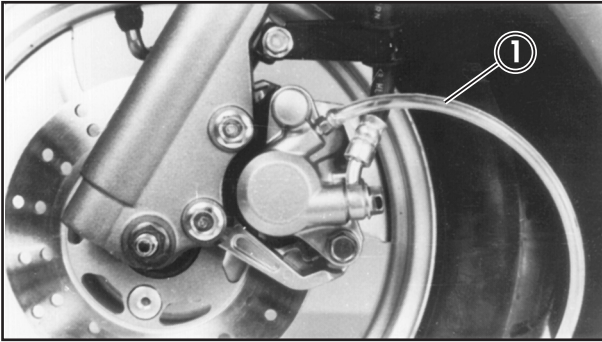

AIR BLEEDING (HYDRAULIC BRAKE SYSTEM)

1. Bleed:
 - Brake fluid



Steps for air bleeding:

- a. Add the appropriate amount of brake fluid to the sump.
- b. Install the diaphragm. Take care not to spill fluid or to let the sump overflow.
- c. Connect the clean plastic tube ①.
- d. Place the other end of the tube in a container.
- e. Slowly apply the brake lever several times.
- f. Pull the lever inwards. Keep it in this position.
- g. Loosen the bleed screw and tighten the lever as far as it will go.
- h. Tighten the bleed screw when it has reached its limit, afterwards loosen the lever.
- i. Repeat steps (e) to (h) until the air bubbles in the system have been removed.
- j. Add brake fluid to the correct level.

WARNING

Check the brake operation after bleeding the system.

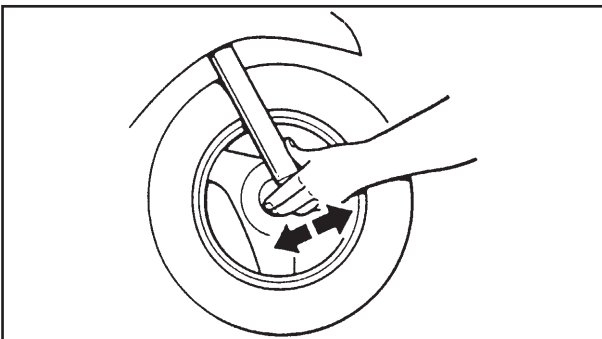

STEERING ADJUSTMENT

1. Check:
 - Steering assembly bearings Press down the bottom of the fork and carefully move the assembly forwards and backwards.
Loose → Adjust

INSPECTION OF TYRES

INSP
ADJ

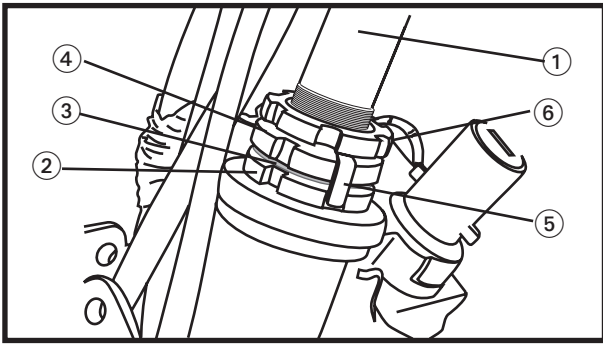

Steps for tightening the steering nut:

1. Tighten the lower ring ② to 3.8 m • kg.
2. Loosen the lower ring nut ② 1/2 of a turn and tighten to 0.65 m • kg.
3. Check the steering for smooth operation.
4. Install rubber washer ③.
5. Install central ring nut ④ and hand tighten until the lower and central ring nuts slots align.
6. Install the lock washer ⑤.
7. Supporting the lower and central ring nuts, install and thighten the upper ring nut to 7.5 m • kg.

INSPECTION OF TYRES

⚠ WARNING

- Do not try to use tubeless tyres in a wheel designed only for inner tube tyres. This may cause damage to the tyre and personal injury due to a puncture.

Wheel	Tyre
Tube type	Only inner tube type
tubeless type	With or without tube type

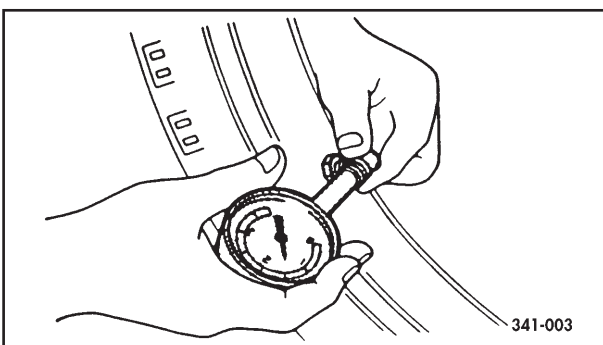

1. Measure:
 - Air pressure
 - Outside specified value → Adjust

Basic weight:		
With oil sump and fuel tank full	87 kg	
Maximum load*	155	
Cold tyre pressure	front	Rear
	1.75kg/cm ²	2.00 kg/cm ²

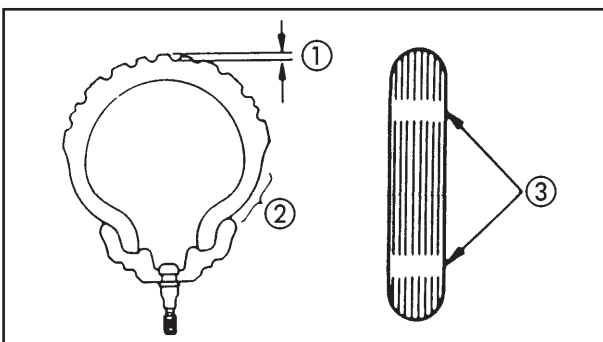

2. Inspect:
 - Tyre surface
 - Worn/Damaged → Change

	Minimum depth of thread of tyres 0.8 mm
--	--

- ① Thread depth
- ② Side wall
- ③ Wear indicator

WHEEL INSPECTION

1. Inspect:
 - Wheels damaged/warped → Replace.

⚠ WARNING: _____

Never try to make even the smallest repairs on wheels.

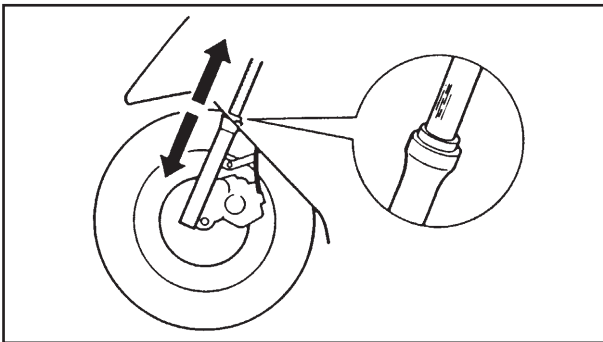

INSPECTION OF REAR FORK

1. Inspect:
 - Rear fork
 - Bent/Damaged → Fork bar → Change
 - Oil leaks → Seals → Change
 - Rough operation → Fork assembly → Change

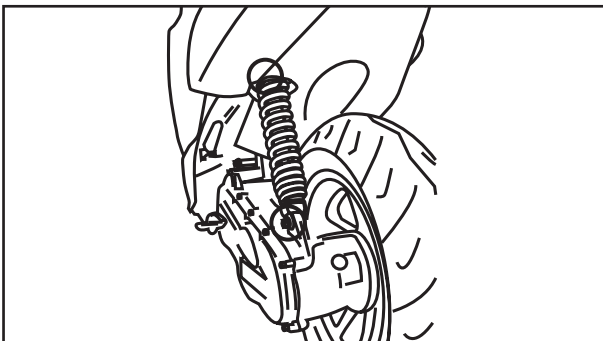

REAR SHOCK ABSORBER INSPECTION

1. Inspect:
 - Rear shock absorber
 - Oil leaks/Damage → Replace
2. Check
 - Coupling torque

	Upper (nut)	3.2 m • kg
	Lower (bolt)	1.8 m • kg



ELECTRICAL SYSTEM

BATTERY INSPECTION

1. Remove:
 - Battery cover
See "REAR BODYWORK" section

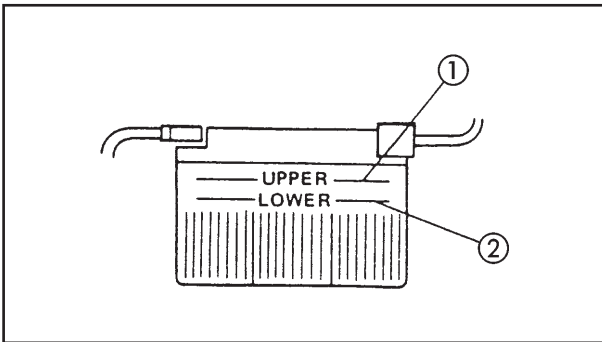

2. Inspect:
The fluid level between the maximum ① and minimum ② marks.
Incorrect → Refill

ATTENTION: _____

Add only distilled water; tap water contains minerals which are damaging to the battery.

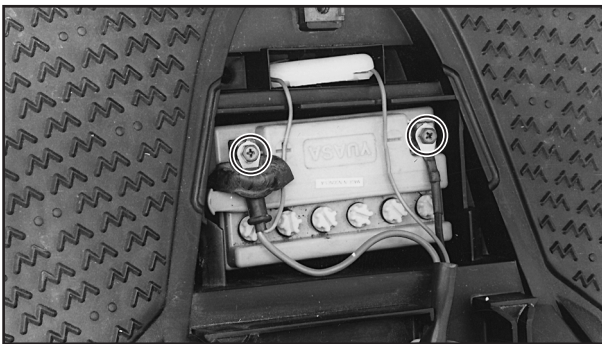

3. Inspect:
 - Battery terminals
Dirty terminals → Clean with a wire brush
Bad connection → Correct

NOTE: _____

Once the terminals are clean, apply a thin cover of grease.

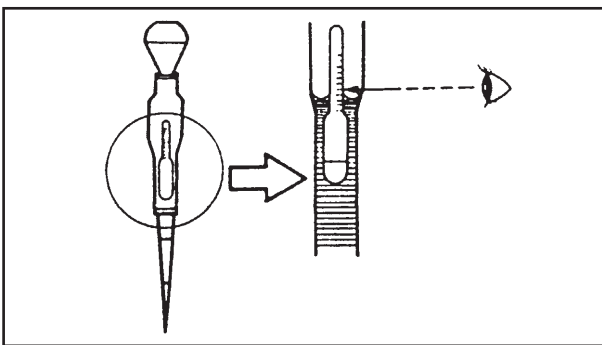

4. Check:
 - The density of the electrolyte
Less than 1,280 → Recharge the battery

**Charge current:
0.3 Amps/10 Hrs**

**Electrolyte density:
1,280 at 20 °C (68 °F)**



Change the battery in the following cases:

- When the voltage does not reach the specified value and bubbles do not appear, even after several hours of charging.
- When one or more of the trays become sulphated, which can be seen when the plates become white or material accumulates on the bottom.
- When the density readings after slow charging over a prolonged period, indicate that one of the trays is lower than the other.
- When the warping or ondulation of one of the plates or insulators is evident.

ATTENTION:

Always charge new batteries before assembling them, in order to guarantee maximum performance.



⚠ WARNING

The electrolyse in the battery is dangerous; it contains sulphuric acid and is consequently poisonous and very caustic.

Always follow the following preventive measures:

- Avoid physical contact with the electrolyte which can cause serious burns or permanent damage to sight.
- Use protective glasses when handling batteries or working near them. Antidote (EXTERNAL):
- SKIN - Wash with water.
- EYES - Wash with water for 15 minutes and consult a doctor immediately.

Antidote (INTERNAL):

- Drink large quantities of water or milk, followed by milk of magnesia, beaten egg of vegetable oil.
- See a doctor immediately.

Batteries also generate explosive hydrogen gas, so that the following preventive measures should always be observed:

- Charge the batteries in a well ventilated area.
- Maintain the batteries away from fire, sparks or flames (for example, soldering equipment, lit cigarettes, etc.).
- DO NOT SMOKE while batteries are being charged or handled.

MAINTAIN BATTERIES AND THE ELECTROLYSE OUT OF THE REACH OF CHILDREN.

INSPECTION OF FUSES

1. Remove:
 - The battery cover
See the "FRONT BODYWORK" section

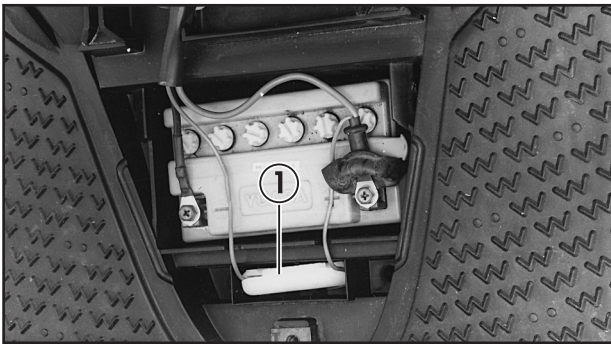

2. Inspect:
 - Fuse ①
Defective → Replace



Steps to be taken for blown fuses:

- Disconnect the ignition and circuit.
- Install a new fuse of the correct amperage.
- Connect the switches to check the correct operation of the electrical device.
- If the fuse blows immediately after, check the circuit concerned.



⚠ WARNING

Do not use fuses of a higher amperage than that recommended. This can cause extensive damage to the electrical system and fire.

Description	Amperage	Quantity
Principal	7A	1

ADJUSTMENT OF HEADLAMP BEAM / REPLACEMENT OF HEADLAMP BULB

INSP
ADJ

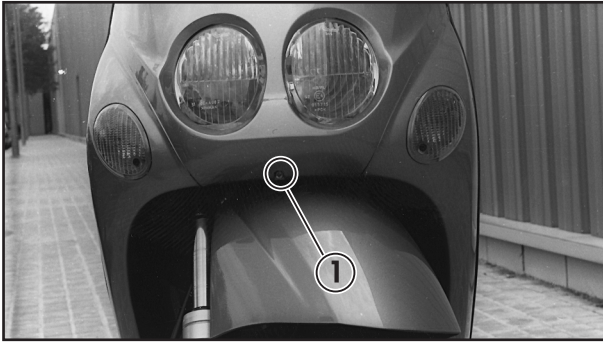

ADJUSTMENT OF HEADLAMP BEAM

1. Adjust:
 - Headlamp (vertically)

To raise the beam →
Turn the screw inwards
To lower the beam →
Turn the screw outwards

REPLACEMENT OF HEADLAMP BULB

1. Remove:
 - Front fairing
2. Disconnect
 - Headlamp cables

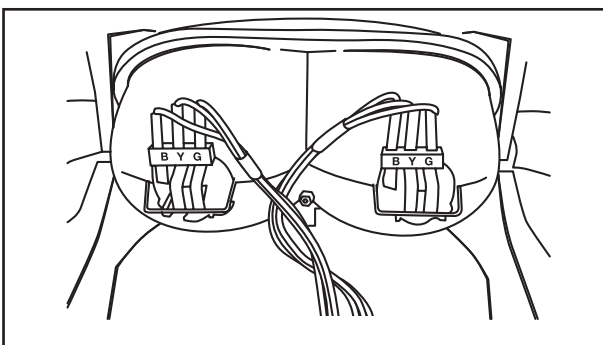

3. Remove:
 - Headlamp bulb cover
 - Headlamp bulb
4. Install:
When the front fairing is installed, reverse the removal process

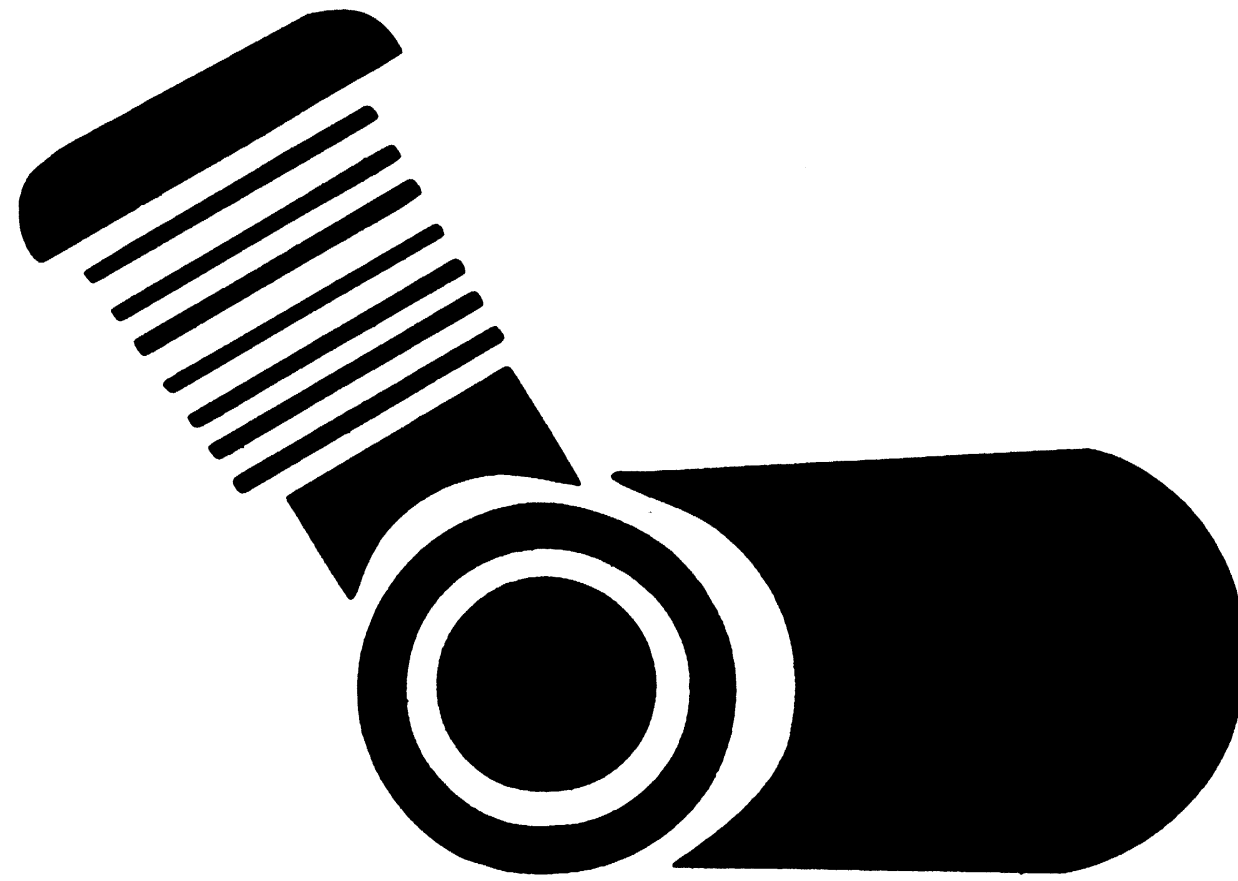

ENG

4



CHAPTER 4 GENERAL OVERHAUL OF ENGINE

ENGINE REMOVAL	4-1
REAR COVER AND FOOTREST PANEL	4-1
CARBURETTOR	4-1
SILENCER ASSEMBLY	4-1
CABLES AND TUBES	4-2
REMOVAL OF ENGINE	4-3
DISASSEMBLY THE ENGINE	4-4
REAR WHEEL	4-4
CENTRAL SUPPORT	4-4
CYLINDER HEAD AND CYLINDERS	4-4
PISTON PINS AND PISTON	4-4
KICK STARTER.....	4-5
PRIMARY PULLEY WHEEL	4-6
SECONDARY PULLEY WHEEL.....	4-6
STARTER SYSTEM	4-7
TRANSMISSION	4-8
MAGNETIC FLYWHEEL	4-8
AUTOLUBRICATION PUMP	4-9
CRANKCASE AND CRANKSHAFT	4-9
INSPECTION AND REPAIR	4-11
CYLINDER HEAD	4-11
CYLINDER AND PISTON	4-11
PISTON RINGS	4-13
PISTON PIN AND PISTON PIN BEARING	4-14
KICK STARTER	4-15
TRANSMISSION.....	4-16
AUTOLUBRICATION PUMP.....	4-16
CRANKSHAFT	4-16
PRIMARY PULLEY WHEEL	4-17
SECONDARY PULLEY WHEEL	4-18
TRAPEZOIDAL BELT.....	4-19
GEARS AND STARTER CLUTCH	4-19
ASSEMBLY AND ADJUSTMENT OF ENGINE	4-21
CRANKSHAFT AND CRANKCASE.....	4-21
AUTOLUBRICATION PUMP.....	4-23
FLYWHEEL MAGNET	4-24
TRANSMISSION.....	4-25
STARTER MOTOR.....	4-27
SECONDARY PULLEY WHEEL	4-29
PRIMARY PULLEY WHEEL	4-29
STARTER PEDAL	4-30
PISTON AND PISTON PIN	4-35
CYLINDER AND HEAD	4-36
ENGINE ASSEMBLY	4-38



GENERAL OVERHAUL OF THE ENGINE

REMOVAL OF ENGINE

REAR BODYWORK AND FOOTREST

1. Remove:
 - Side covers (left and right)
 - Rear cover
 - Footrest panel See section in chapter 3 "REAR BODYWORK AND FOOTREST"

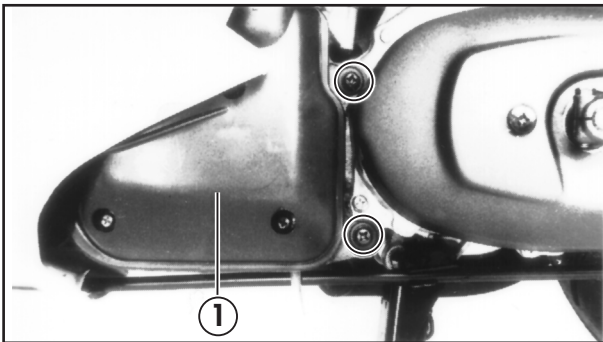

CARBURETTOR

1. Remove:
 - Air filter box assembly ①

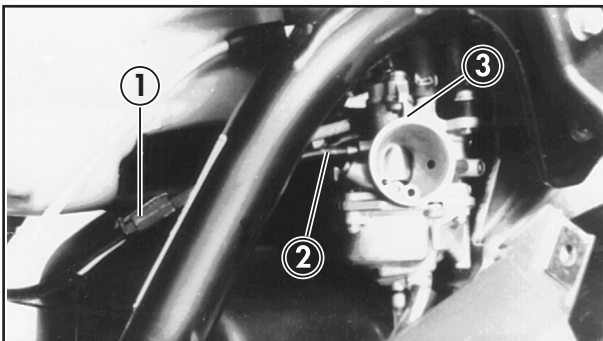

2. Disconnect:
 - Autochoke wire ①
 - Throttle cable
3. Remove:
 - Oil discharge tube ②
 - Fuel supply tube
 - Carburettor ③

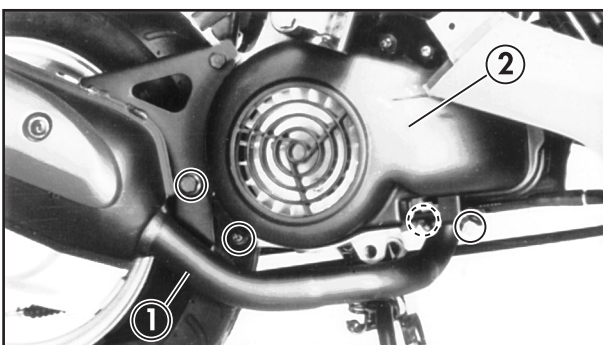

SILENCER ASSEMBLY

1. Remove:
 - Silencer assembly ①
 - Ventilator cover ②

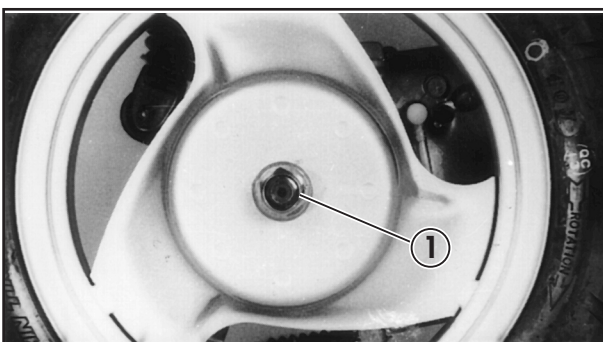

2. Loosen:
 - Rear axle nut ①

NOTE: _____

When the rear wheel axle nut is loosened, apply the rear brake.



CABLES AND PIPES

1. Remove:

- Oil pipe ① from side of oil pump.

NOTE: _____

Position oil pipe so that the oil does not spill out.

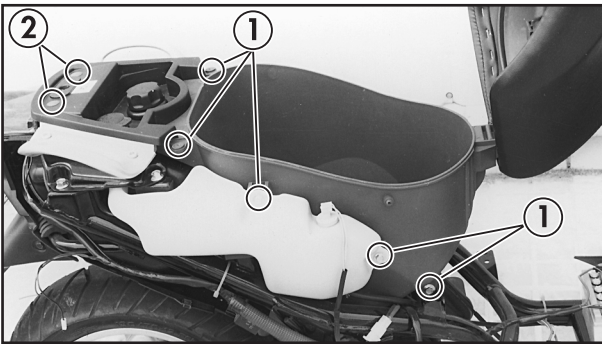

2. Remove:

- Bolts ① (trunk)
- Overflow bowl rivets

NOTE: _____

To remove the overflow bowl, take off the fuel and oil caps and replace them immediately after removing the bowl.

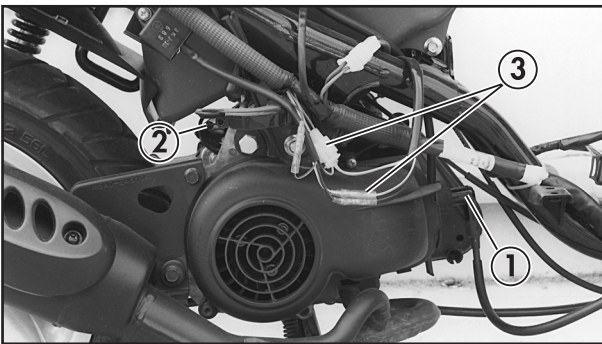

3. Disconnect:

- Battery cable ①
- Starter motor cable ②
- Magnetic flywheel cable ③
- Spark plug pipe

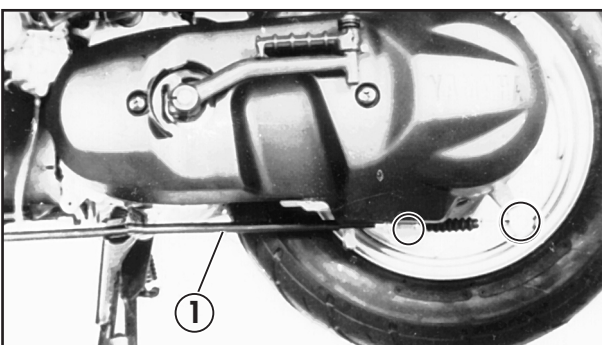

4. Remove:

- Rear brake cable ①

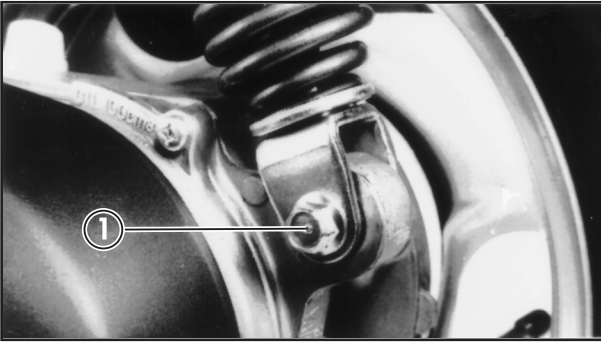

ENGINE REMOVAL

1. Remove:
 - Rear shock absorber screw ① (lower)
2. Remove:
 - Engine assembly screw ①
 - Engine Lift the frame and remove the engine
3. Place the frame on a suitable support

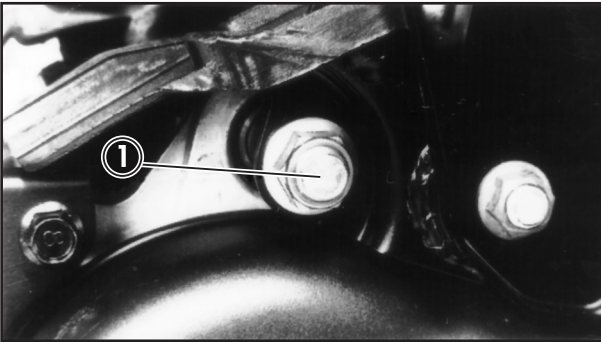

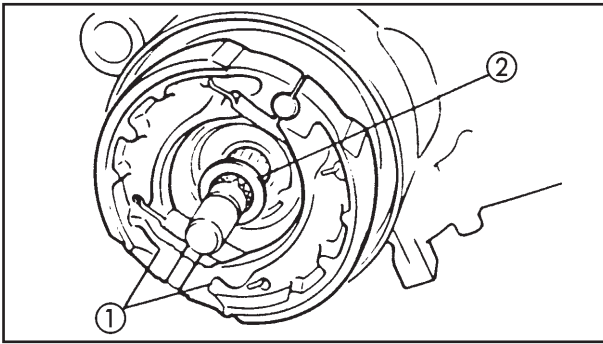

DISASSEMBLY ENGINE

REAR WHEEL

- Remove:
 - Rear wheel
 - Brake shoes (1)
 - Flat washer (2)

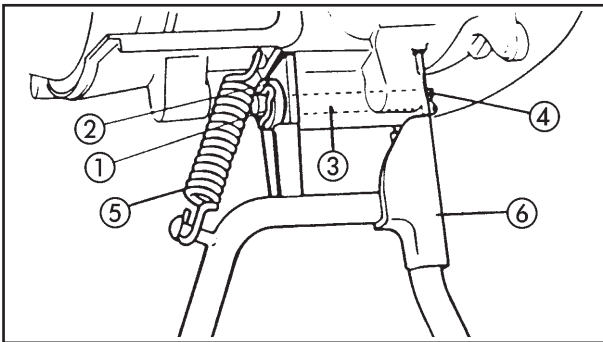

CENTRAL STAND

- Remove:
 - Clip (1)
 - Rubber washer (2)
 - Axle (3)
 - Clasp (4)
 - Spring (5)
 - Central stand (6)

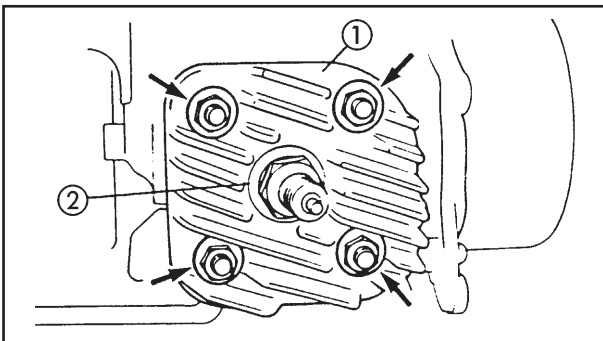

CYLINDER HEAD AND CYLINDER

- Remove:
 - Cover
 - Cylinder head (1)
 - Cylinder head gasket

NOTE:

- Before loosening the cylinder head, loosen the spark plug (2).
- The position nuts of the cylinder head should be loosened by 1/2 a turn each time and then removed.

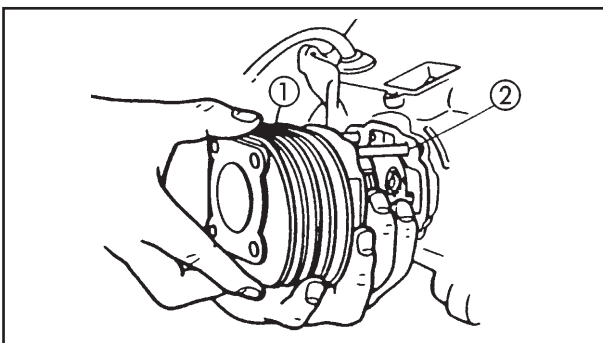

- Remove:
 - Cylinder (1)
 - Cylinder gasket (2)

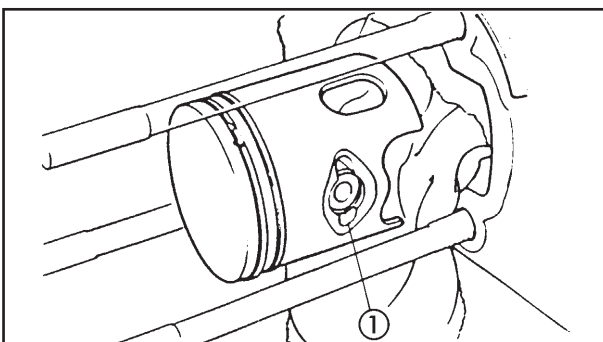

PISTON PIN AND PISTON

- Remove:
 - Piston pin clip (1)

NOTE:

Before removing the piston pin clip, cover the crankcase with a clean cloth so that it does not accidentally fall into the crankcase.

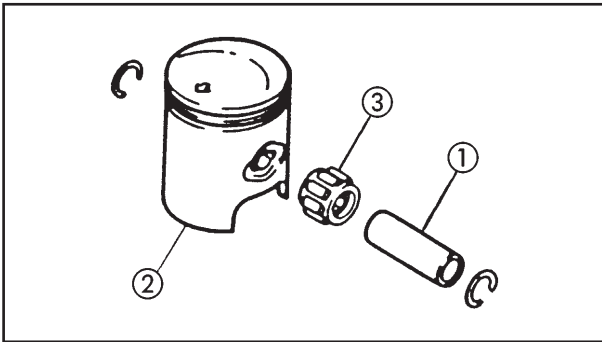

2. Remove:
- Piston pin ①
 - Piston ②
 - Piston pin bearing ③

ATTENTION: _____

Do not use a hammer to take out the piston pin.

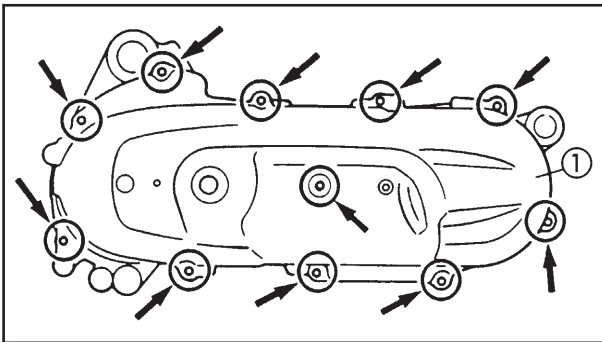

KICKSTART SYSTEM

1. Remove:
- Kickstart pedal
 - Crankcase cover ① (left)

2. Remove:
- Guide(air filter)
 - Air filter

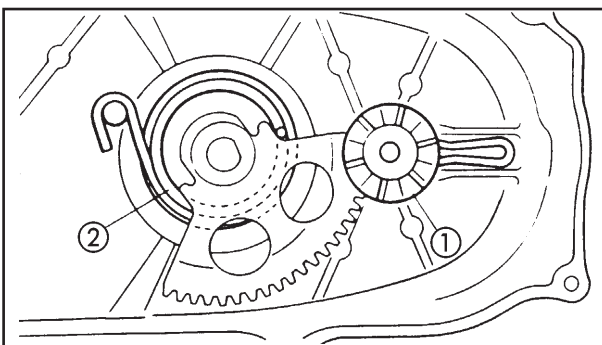

3. Remove:
- Pedal gear ①

NOTE: _____

When the pedal gear removed, move the pedal axle.

4. Unhook:
- Return spring ②

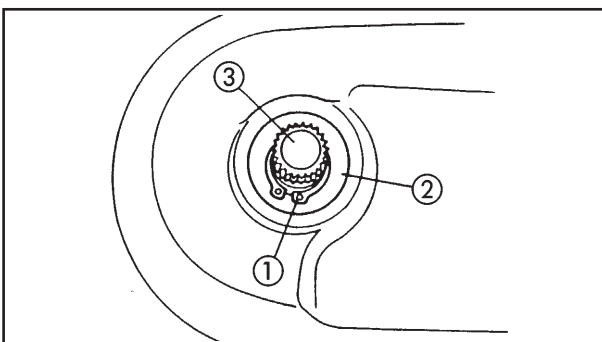

5. Remove:
- Circlip ①
 - Flat washer ②
 - Pedal axle ③

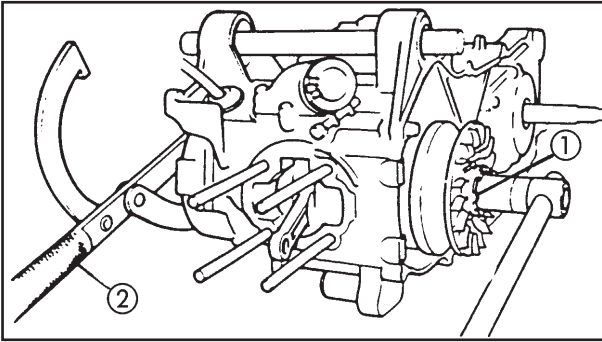

PRIMARY PULLEY WHEEL

1. Remove:
 - Fan
2. Remove:
 - Nut ① (primary pulley wheel)

NOTE:

When the nut is loosened (primary pulley wheel), support the magnetic flywheel using the engine wheel support tool ②

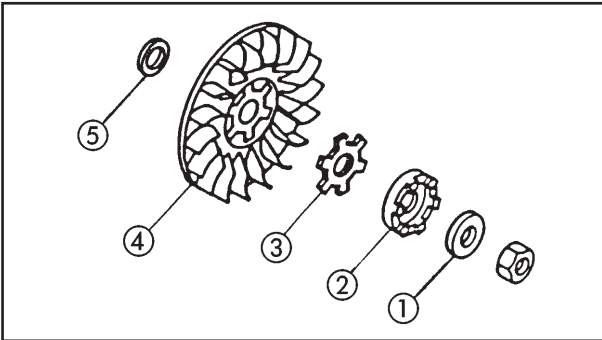

Engine wheel holding tool:
90890-01235

3. Remove:
 - Conical spring washer ①
 - One-way clutch ②
 - Washer ③
 - Fixed primary pulley wheel ④
 - Shim ⑤
 - Trapezoidal belt
4. Remove:
 - Hub ①
 - Primary pulley wheel assembly ②

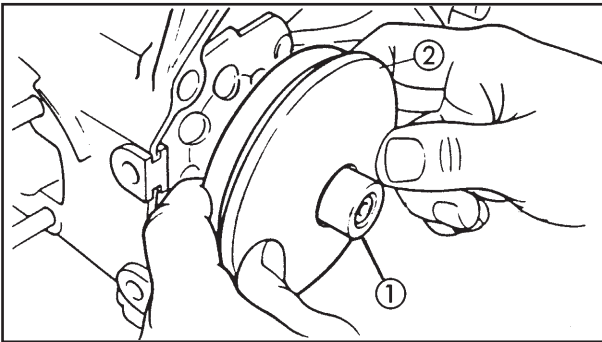

SECONDARY PULLEY WHEEL

1. Remove:
 - Nut ① (secondary pulley wheel)

NOTE:

Support the secondary pulley wheel using the pulley wheel clamp ③.

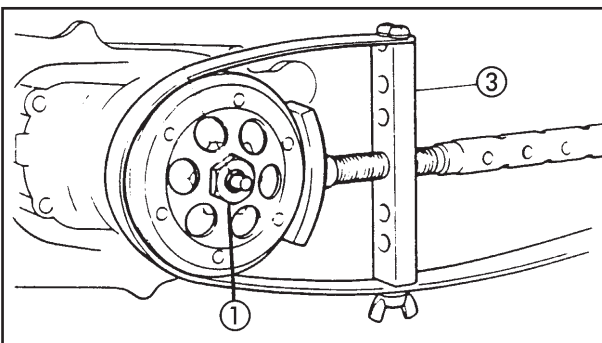

Pulley wheel clamp:
90890-01701

2. Remove:
 - Clutch drum ①
 - Secondary pulley wheel assembly ②
 - Crankcase cover gasket
 - Centring devices

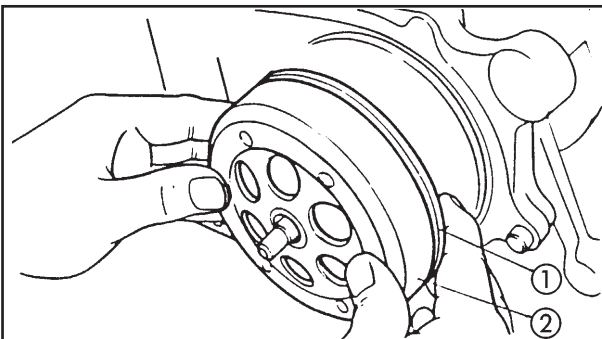

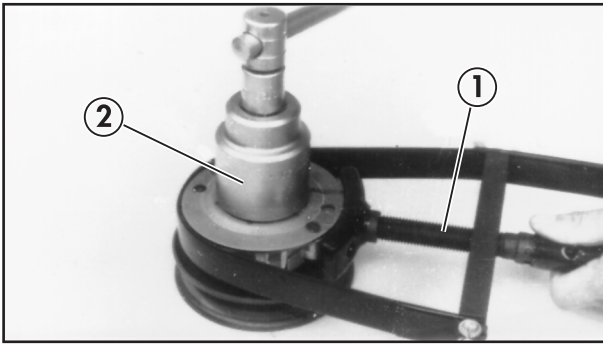

3. Apply:
 - Pulley wheel clamp ①
 - Nut spanner ② (41MM)



Pulley wheel clamp:
90890-01701

4. Loosen:
 - Clutch positioning nut

ATTENTION: _____

Do not remove the clutch positioning nut yet.

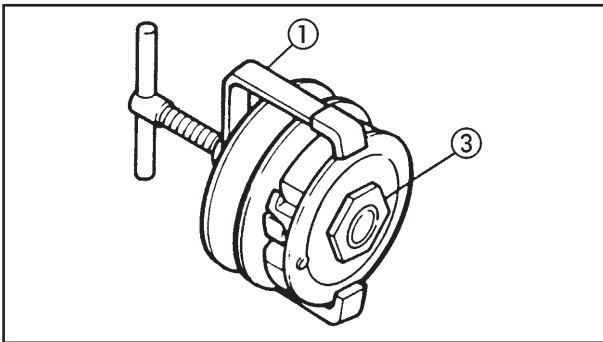

5. Apply:
 - Clutch spring compressor ①



Clutch spring compressor:
90890-01337

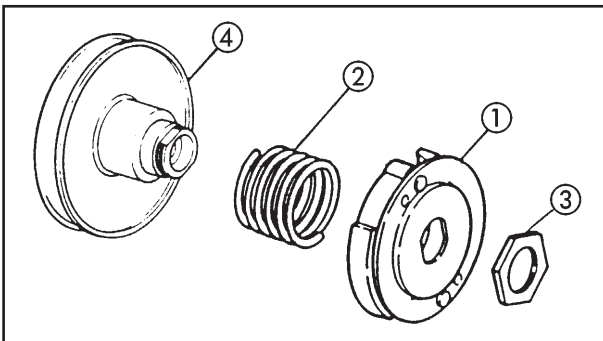

6. Remove:
 - Clutch positioning nut ③
7. Remove:
 - Clutch assembly ①
 - Clutch spring ②
 - Spring seat ④
 - Guide pins
 - Secondary sliding pulley wheel

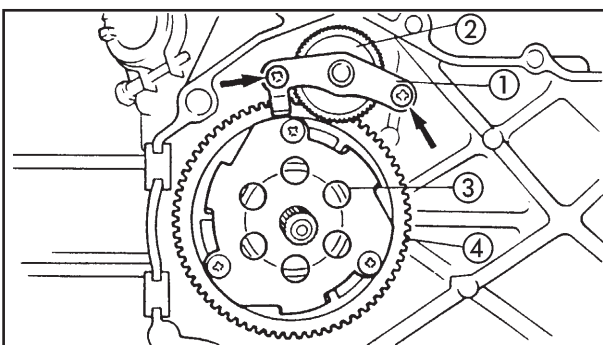

STARTER SYSTEM

1. Remove:
 - Plate ① (intermediate gearing)
 - Intermediate gearing ②
 - Starter clutch assembly ③
 - Washer
 - Starter wheel gearing ④
2. Remove:
 - Bushing ①
 - Bearing ②
 - Washer ③
 - Starter motor

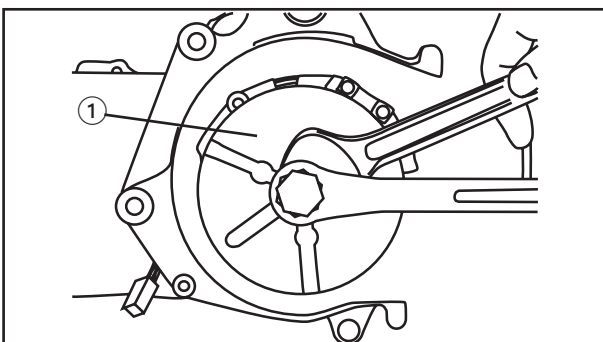

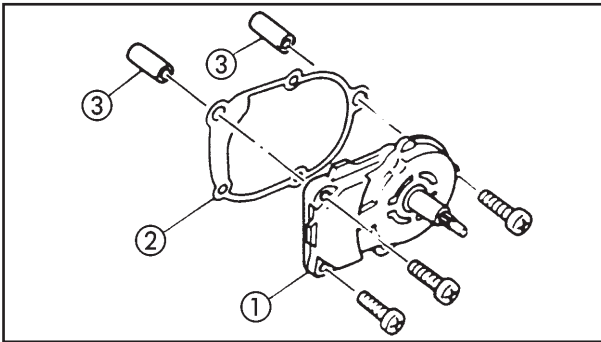

TRANSMISSION

- Remove:
 - Transmission box cover ①
 - Gasket ②
 - Centring devices ③

NOTE:

Before proceeding to disassemble the transmission cap, empty the oil.

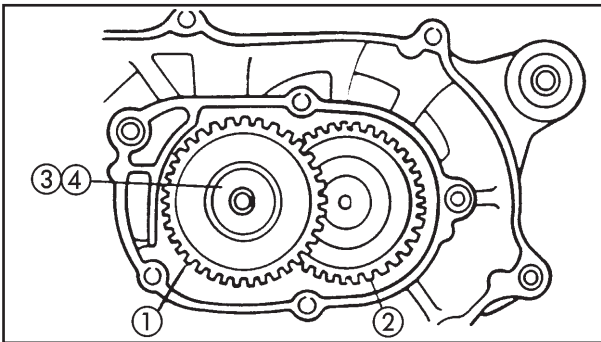

- Remove:
 - Main axle ①
 - Drive axle ②
 - Flat washer ③
 - Conical spring washer ④

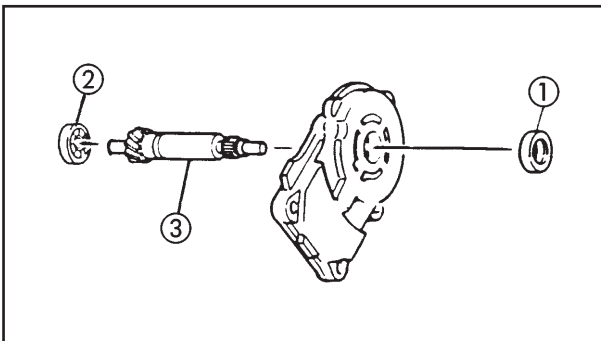

- Remove:
 - Oil seal ①
 - Bearing ②
 - Secondary pulley wheel axle ③

MAGNETIC FLYWHEEL

- Remove:
 - Nut ① (rotor)
 - Flat washer

NOTE:

Support the rotor to loosen the nut with the engine flywheel support tool ②.

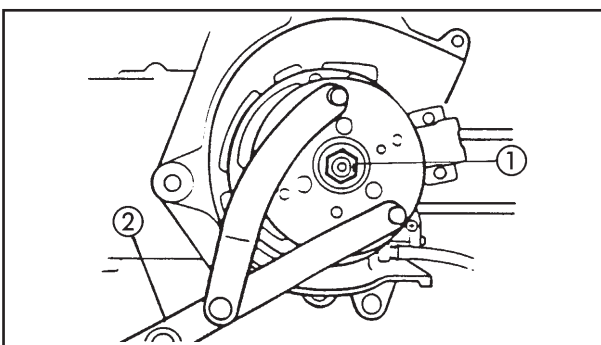

	Engine flywheel support tool 90890-01235
---	--

- Remove:
 - Rotor ①
 - Woodruff key

Use the magnetic flywheel extractor ②

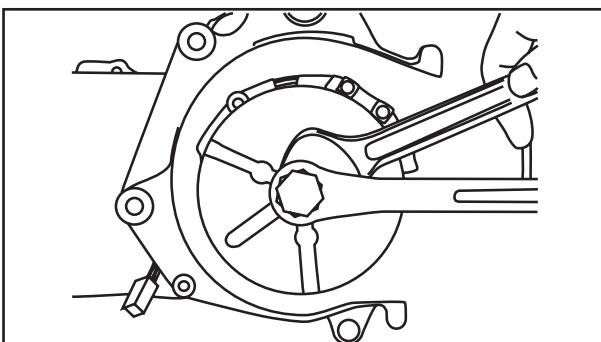

	Magnetic flywheel extractor 90890-01362
---	---

- Stator assembly
- Gasket

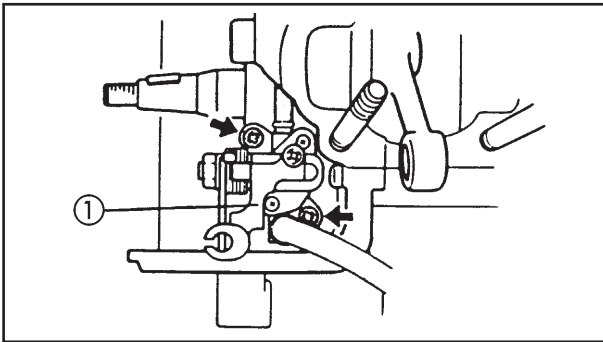

AUTOLUBRICATION PUMP

1. Remove:
 - Autolubrication pump ①

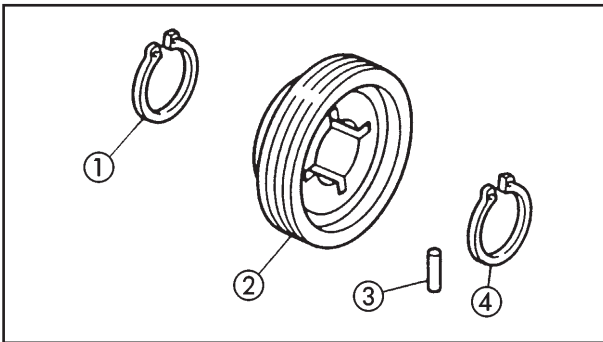

2. Remove:
 - Elastic circlip ①
 - Pump drive gearing ②
 - Pin ③
 - Elastic circlip ④

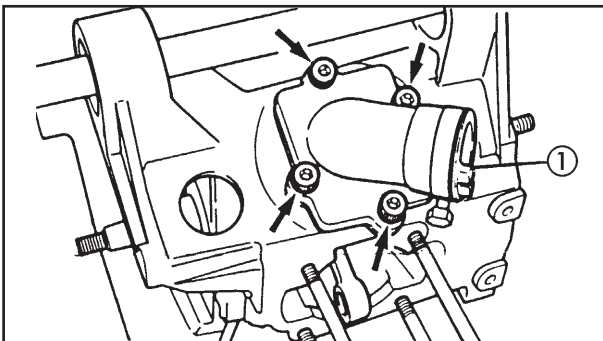

3. Remove:
 - Carburetor gasket ①
 - Reed valve ②
 - Reed valve gasket ③

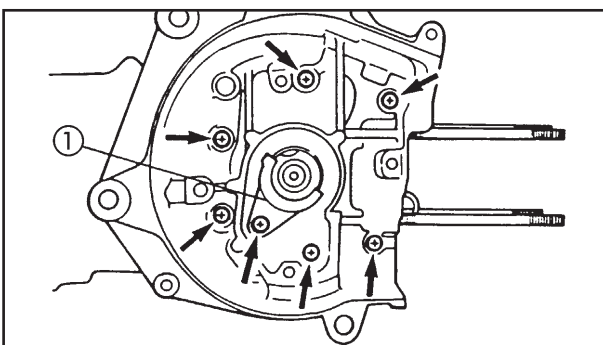

CRANKCASE AND CRANKSHAFT

1. Remove:
 - Oil seal catch ①
 - Screws (crankcase) ②

NOTE: _____

Loosen each screw 1/4 of a turn and remove them after loosening them.

2. Apply:
 - Crankcase separation tool ①



NOTE: _____

Fully tighten the positioning nuts of the tool, but ensure that the tool body is parallel with the box. If necessary, slightly loosen one of the screws to level the body of the tool.

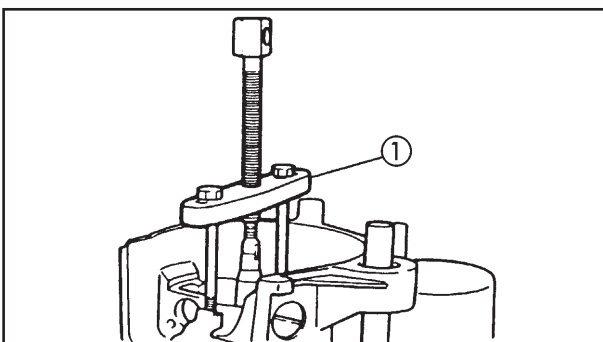

DISASSEMBLY THE ENGINE

ENG

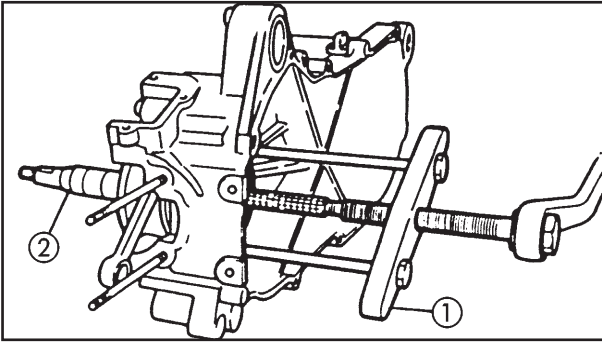

3. Remove:
 - Crankcase (right)
While pressure is applied, strike alternately on the engine assembly hubs.
4. Apply:
 - Crankcase separation tool ①



Crankcase separation tool
90890-01135

5. Remove:
 - Crankshaft ②

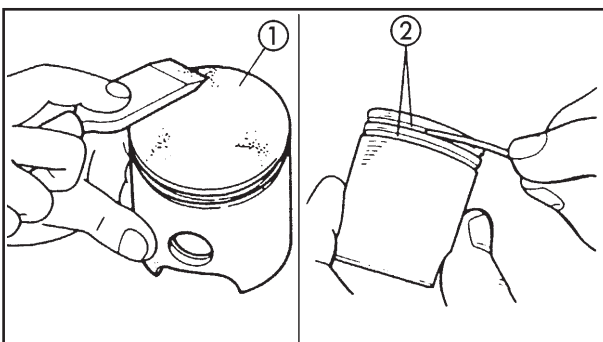
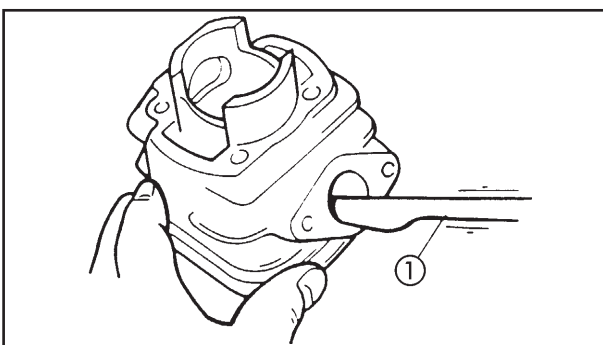
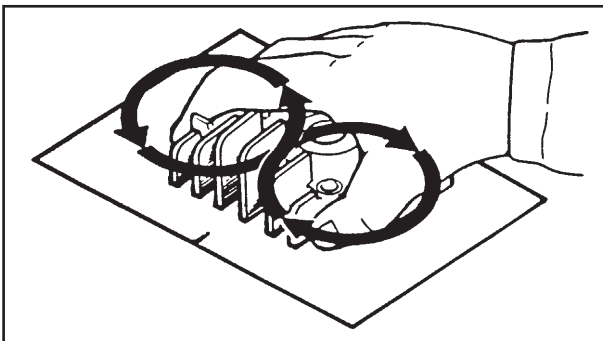
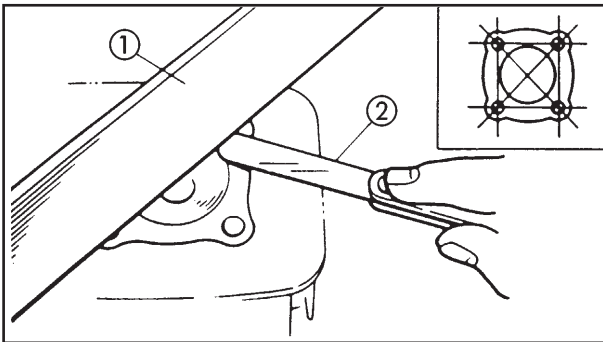
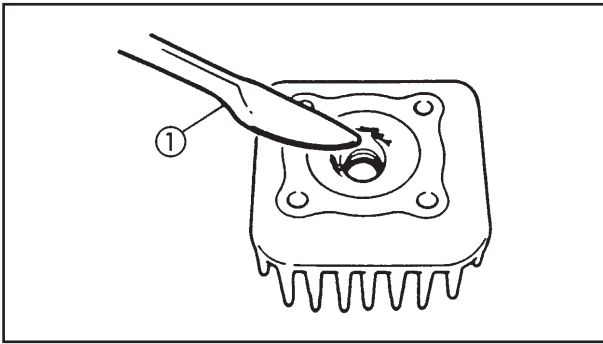

INSPECTION AND REPAIR

CYLINDER HEAD

1. Eliminate:
 - Carbon deposits Use a rounded scraper ①

2. Inspect:
 - Cylinder head warping.
Outside specified value → Rectify



Steps for measuring warping and rectification:

- Join a straight edge ① and a thickness calibration ② on the cylinder head
- Measure the limit of the warping

	Warping limit 0.02 mm
--	---------------------------------

- If the warping is outside the specified value, rectify the cylinder head

NOTE: _____

Turn the cylinder head several times to avoid removing too much material from one side



CYLINDER AND PISTON

1. Eliminate:
 - Carbon deposits Use a rounded file ①

2. Inspect:
 - Cylinder wall Wear/stripping → Rectify or change

3. Eliminate:
 - Carbon deposits ① ②
From the piston crown and ring grooves.

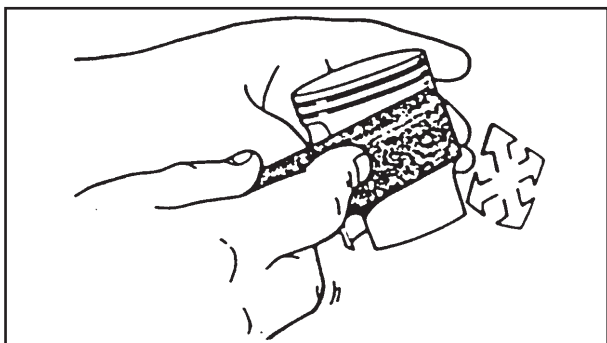

4. Remove:
 - Cracking marks and carbon deposits on piston sides.
5. Inspect:
 - Piston wall
Wear/stripping/damage → Change

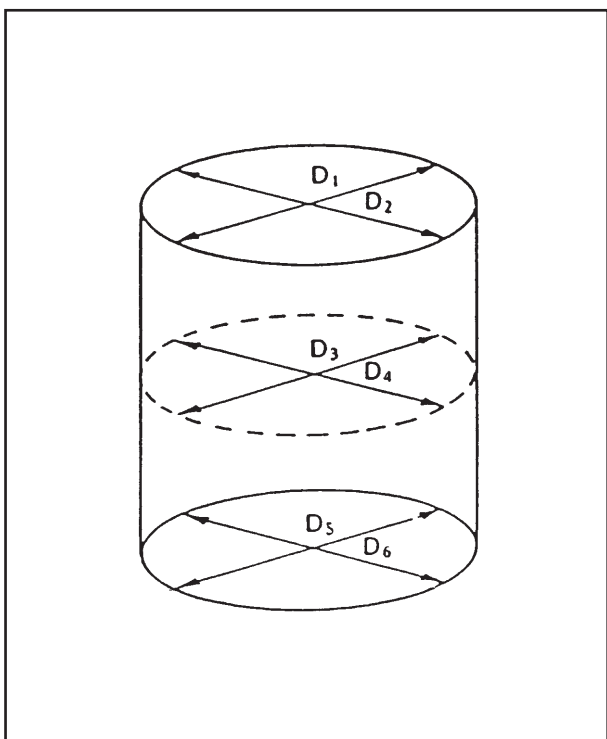

6. Measure:
 - Cylinder piston clearance

Steps for measuring the clearance of the cylinder piston

First step:

- Measure the lower diameter “C” with a dial gauge.

NOTE:

Measure the inner diameter of cylinder “C” in parallel and at right angles to the crankshaft. Then find the mean of the measurements.

	Standard	Wear limit
Inner diameter of cylinder “C”	40.0 mm	40.10 mm
Taper “T”	-	0.05 mm
Eccentricity “R”	-	0.01 mm
“C” = Maximum D		
“T” = (Maximum D₁ or D₂) - (Maximum D₅ or D₆)		
“R” = (Maximum D₁ D₃ or D₅) - (Maximum D₂ D₄ or D₆)		

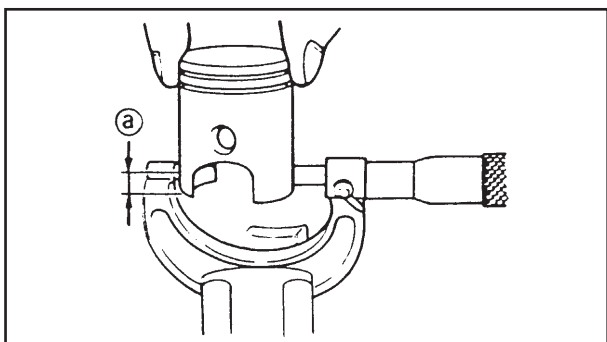

- If this is outside the specified value, rectify or change the cylinder, change the piston and the set of rings.

Second step:

- Measure the diameter of the piston skirt “P” with a micrometer.
 - Ⓐ 5.0 mm (0.20 in) from the inner edge of the piston

	Size of the piston P	
Standard	39.952 ~ 39.997 mm	
1st Clearance	40.25 mm	
2st Clearance	40.50 mm	

- If this is outside the specified value change the piston and the set of rings.

Third step:

- Calculate the clearance of the piston to the cylinder using the following formula:

<p>Clearance of piston to cylinder = Inner diameter of cylinder "C" - Diameter of piston skirt "P"</p>

- If this is outside the specified value, rectify or change the cylinder and change the piston and set of rings.

	<p>Cylinder-piston clearance 0.034 ~ 0.047 mm Limit 0.1 mm</p>
---	--

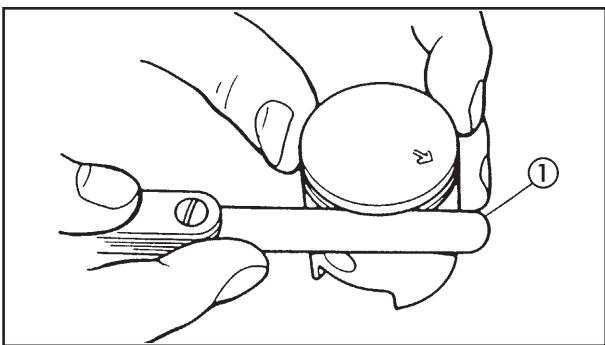

PISTON RINGS

1. Measurement:

- Lateral clearance Outside specified value → Change the piston and/or rings. Use a thickness gauge ①.

	Standard	Limit
Top ring	0.03~0.05 mm	0.10 mm
Second ring	0.03~0.05 mm	0.10 mm

2. Install:

- Piston rings on the cylinder
Press the ring and the piston crown together.

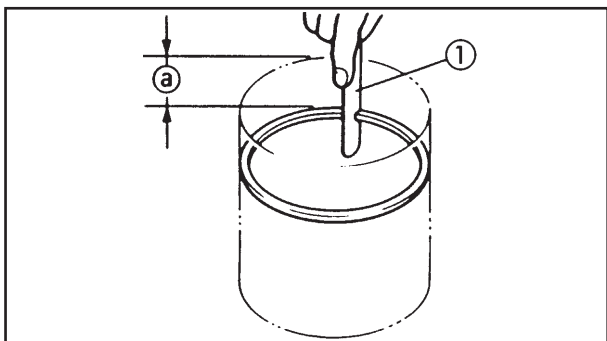

3. Measure:
 - Gap between ends
Outside specified value → Change set of rings.
Use a thickness gauge ①.

	Standard	Limit
Top ring	0.15~0.35 mm	0.60 mm
Second ring	0.15~0.35 mm	0.60 mm

① Measurement point 20 mm (0.8 in)

4. Clearance of piston rings:
The size of the rings is not stamped on its upper part.

Piston ring clearance	
1st Clearance	40.25 mm
2st Clearance	40.50 mm

PISTON PIN AND PISTON PIN BEARING

1. Inspect:
Piston pin
Blue discolouring/Groove → Change, then inspect the lubrication system.

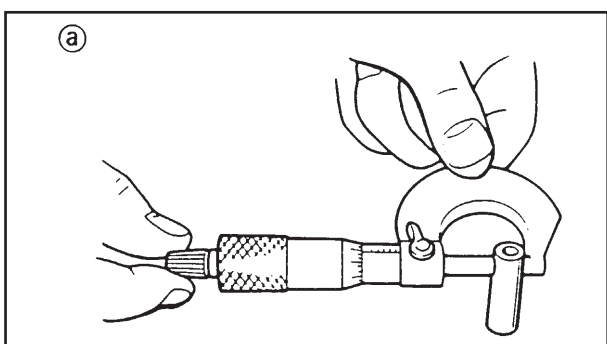

2. Measure:
 - External diameter ① (Piston pin clip)
Outside specified value → Change

	External diameter (piston pin clip) 9.996 ~ 10.00 mm
---	--

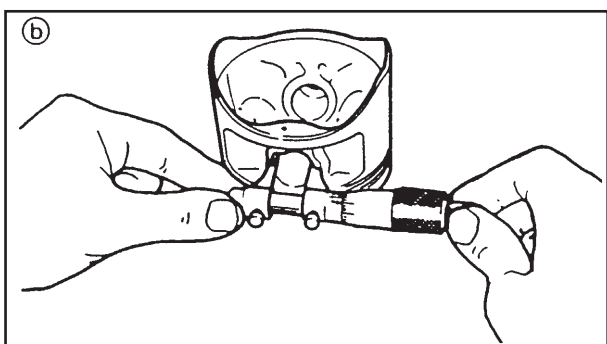

3. Measure:
 - Clearance of piston pin to piston:
Outside specified value → Change the piston

Clearance of piston pin to piston= Size of inner diameter (Piston pin) ② - External diameter (piston pin housing) ①
--

	Clearance of piston pin to piston 0.004 ~ 0.016 mm Limit 0.07 mm
---	--

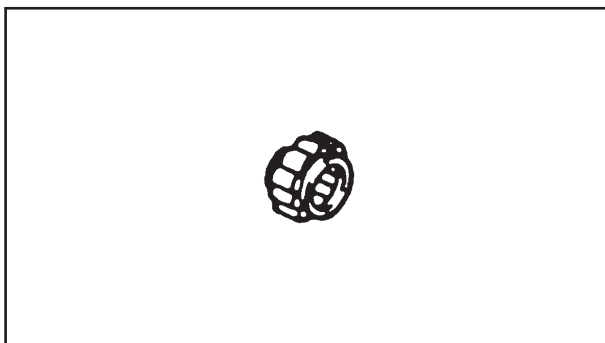

4. Inspect:
 Bearing (piston pin)
 Pitting/Damage → Change

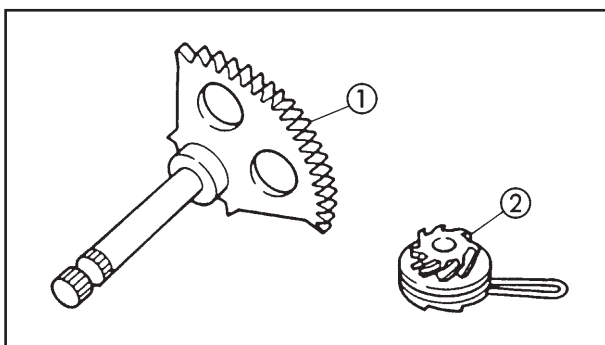

KICKSTART

1. Inspect:
- Pedal gear teeth ①
 - Pedal pinion gear teeth ②
- Burrs/Spalling/Non-uniformity/Wear → Change

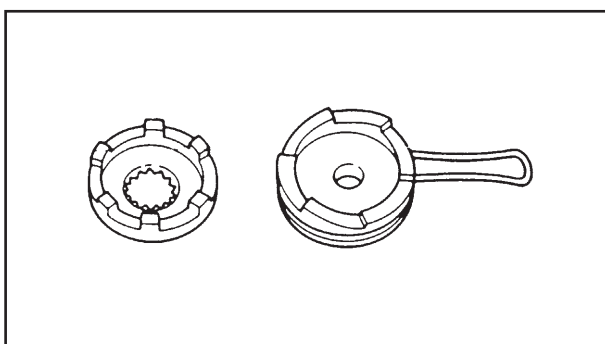

2. Inspect:
- Locking bolt (pedal pinion gear and one way clutch)
- Rounded edges/Wear → Change

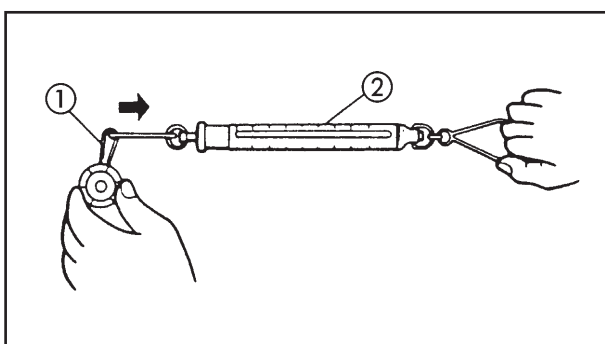

3. Measure:
- Spring tension (pedal pinion gear)
- Outside specified value → Change
 Use a dynamometer



Standard tension
 150 ~ 250 gr

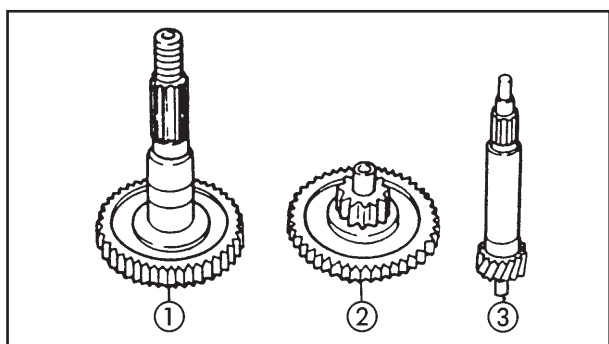

TRANSMISSION

- Inspect:
 - Drive axle ①
 - Main axle ②
 - Secondary pulley wheel axle ③
 Burrs/Spalling/Non-uniformity/Wear → Change

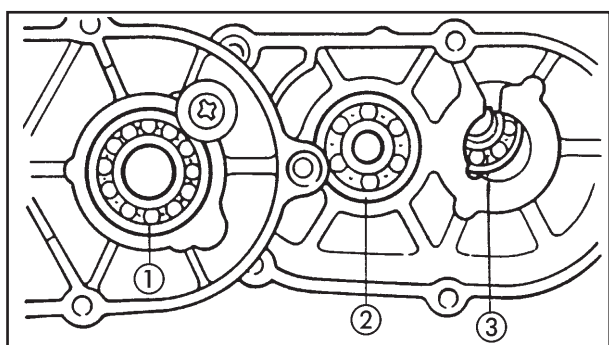

- Inspect:
 - Secondary pulley wheel axle bearing ①
 - Main axle bearing ②
 - Drive axle bearing ③
 Pivot the inner guide of the bearing.
 Excessive play/Non-uniformity → Change
 Pitting/Damage → Change

AUTOLUBRICATION PUMP

Internal wear or poor operation may cause the pump to deviate from its factory adjustment. However, this is very uncommon. If incorrect operation is suspected, inspect the following:

- Inspect:
 - Supply line Obstruction → Apply air under pressure
 - O-ring Wear/Damage → Change
- Inspect:
 - Drive gear teeth of the autolubrication pump ①
 - Gear teeth driven by autolubrication pump ② Pitting/Wear/Damage → Change

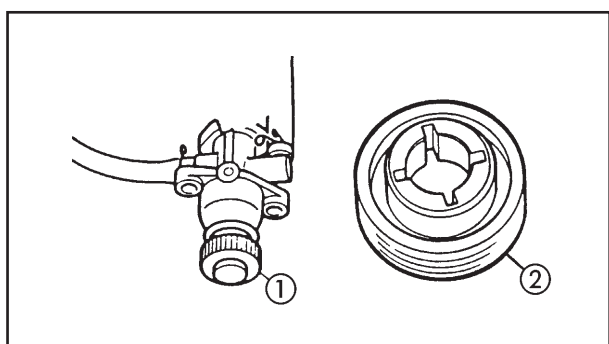

CRANKSHAFT

- Measurement:
 - Deflection limit "C"
 - Clearance on big end side "D"
 - Limit of free play at small end of connecting rod "F"
 Outside specified value → Change.
 Use V blocks, dial gauges and thickness gauge.

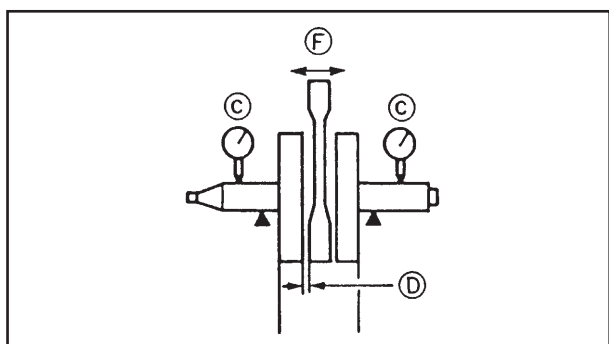



Deflection limit "C":
 0.03 mm
Clearance on big end side "D":
 0.2 ~ 0.5 mm
Free play at small end "F":
 0.4 ~ 0.8 mm

2. Inspect:
 - Bearings (crankshaft) Pivot the inner bearing guide.
 Excessive play/Non-uniformity → Change
 Pitting/Damage → Change

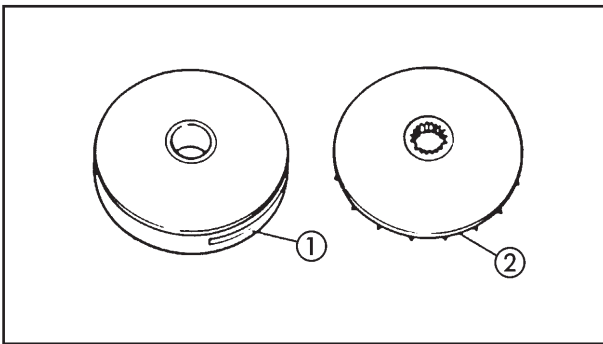

PRIMARY PULLEY WHEEL

1. Inspect:
 - Primary sliding pulley wheel ①
 - Primary fixed pulley wheel ②
 - Wear/Cracks/Striping/Damage → Change

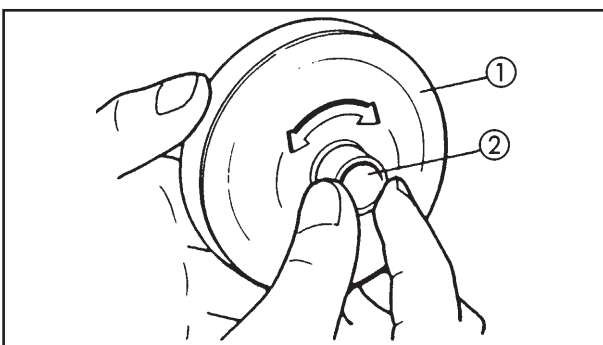

2. Check:
 - Free movement Insert the bushing in the primary sliding pulley wheel and check if there is free movement.
 If it catches or there is excessive play → Change the pulley wheel or the bushing.

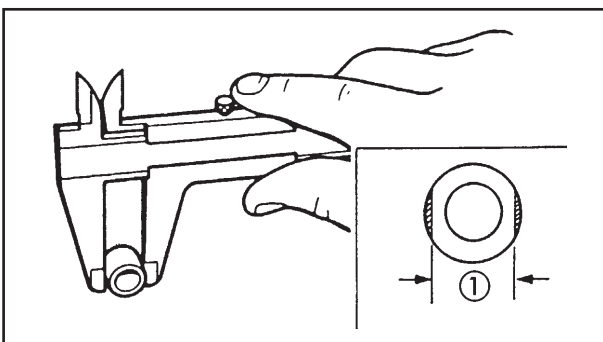

3. Measure:
 - External diameter ① (roller)
 Outside specified value → Change.



External diameter (roller)
 15.0 mm
Limit:
 14,5 mm

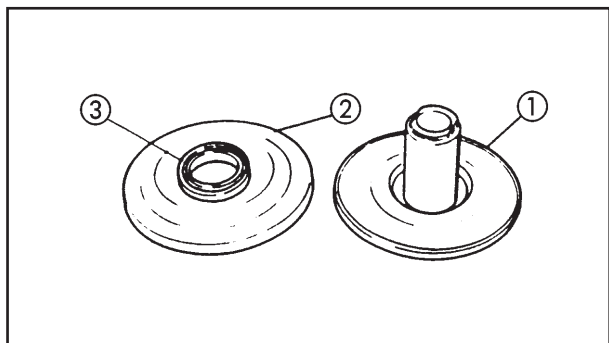

SECONDARY PULLEY WHEEL

- Inspect:
 - Secondary fixed pulley wheel ①
 - Secondary sliding pulley wheel ②
Striping/Cracks/Damage → Change set.
 - Oil seal ③
Damage → Change.

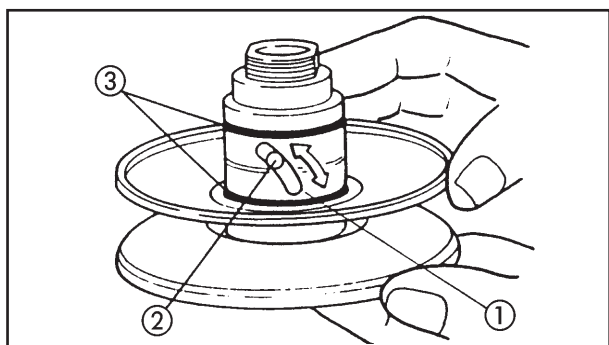

- Inspect:
 - Turning cam groove ①
 - Guide pin ②
Wear/Damage → Change set.
 - O-ring ③
Damaged → Change.

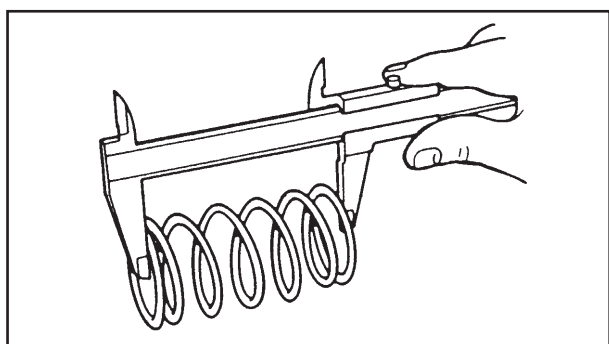

- Measure:
 - Free length of variator spring.
Outside specified value → Change

	Free length of secondary pulley wheel 109.6 mm <Limit> 90.4 mm
--	--

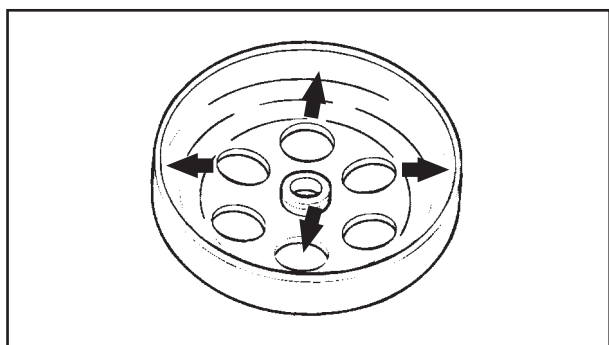

- Inspect:
 - Inner surface of the clutch hub
Oil/Striping → Clean

Oil	Use a cloth dampened with dissolvent
Striping	Use sand paper (polish lightly and uniformly)

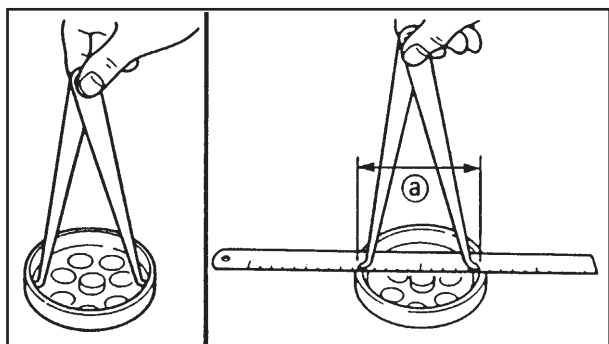

- Measure:
 - Internal diameter of the clutch hub (a)
Outside specified value → Change

	Internal diameter of clutch hub 105.0 mm <Wear limit> 105.4 mm
--	--

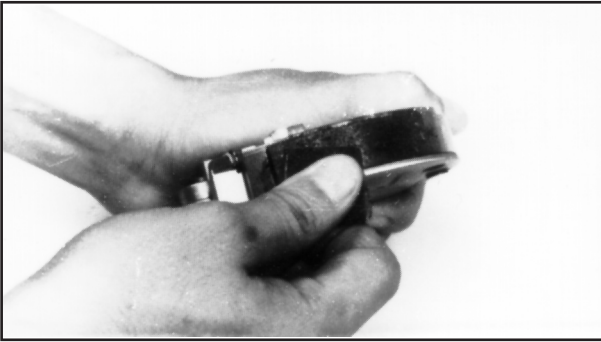

6. Inspect:

- Clutch shoes shiny parts → Polish with sand paper.

NOTE: _____

After using sand paper, clean the polished particles with a cloth.

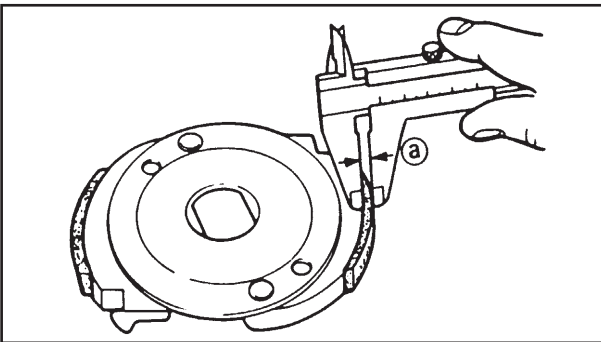

7. Measure:

- Thickness of clutch shoe (a)
Outside specified value → Change

	Thickness of clutch shoe
	2.0 mm
	<Wear limit> 1.0 mm

TRAPEZOIDAL BELT

1. Inspect:

- Trapezoidal belt
Cracks/Wear → Change

NOTE: _____

Replace the trapezoidal belt if it is dirty with oil or grease.

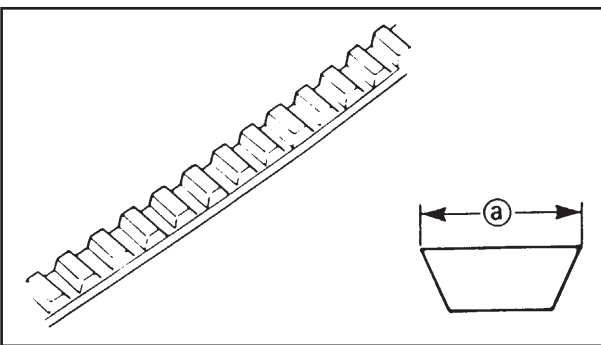

2. Measure:

- Width of trapezoidal belt (a)
Outside specified value → Change

	Width of trapezoidal belt
	16.5 mm
	<Wear limit> 15.7 mm

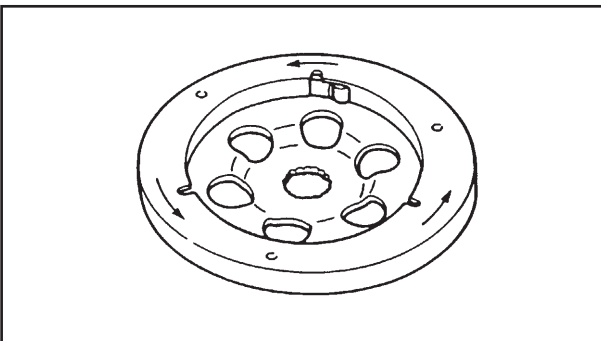

STARTER CLUTCH AND GEARS

1. Inspect:

- Starter clutch Press the conical pin in the direction of the arrow.
Rough operation → Change the starter clutch assembly

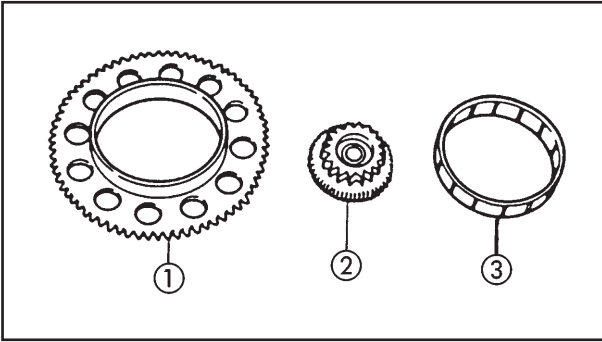

2. Inspect:

- Starter wheel gear teeth ①
- Intermediate gear teeth ②
Burr/Spalling/Non-uniformity/Wear → Change
- Bearing ③ (starter wheel gear)
Pitting/Damage → Change



ASSEMBLY AND ADJUSTMENT OF ENGINE

CRANKSHAFT AND CRAKCASE

- ① Oil seal
- ② Oil seal catch
- ③ Crankcase (right)
- ④ Centring device
- ⑤ Bearing
- ⑥ Crankcase (right)
- ⑦ Bearing
- ⑧ Crankshaft pin
- ⑨ Connecting rod
- ⑩ Crankcase (left)
- ⑪ Bearing
- ⑫ Engine mounting spacer
- ⑬ Crankcase (left)
- ⑭ Oil seal

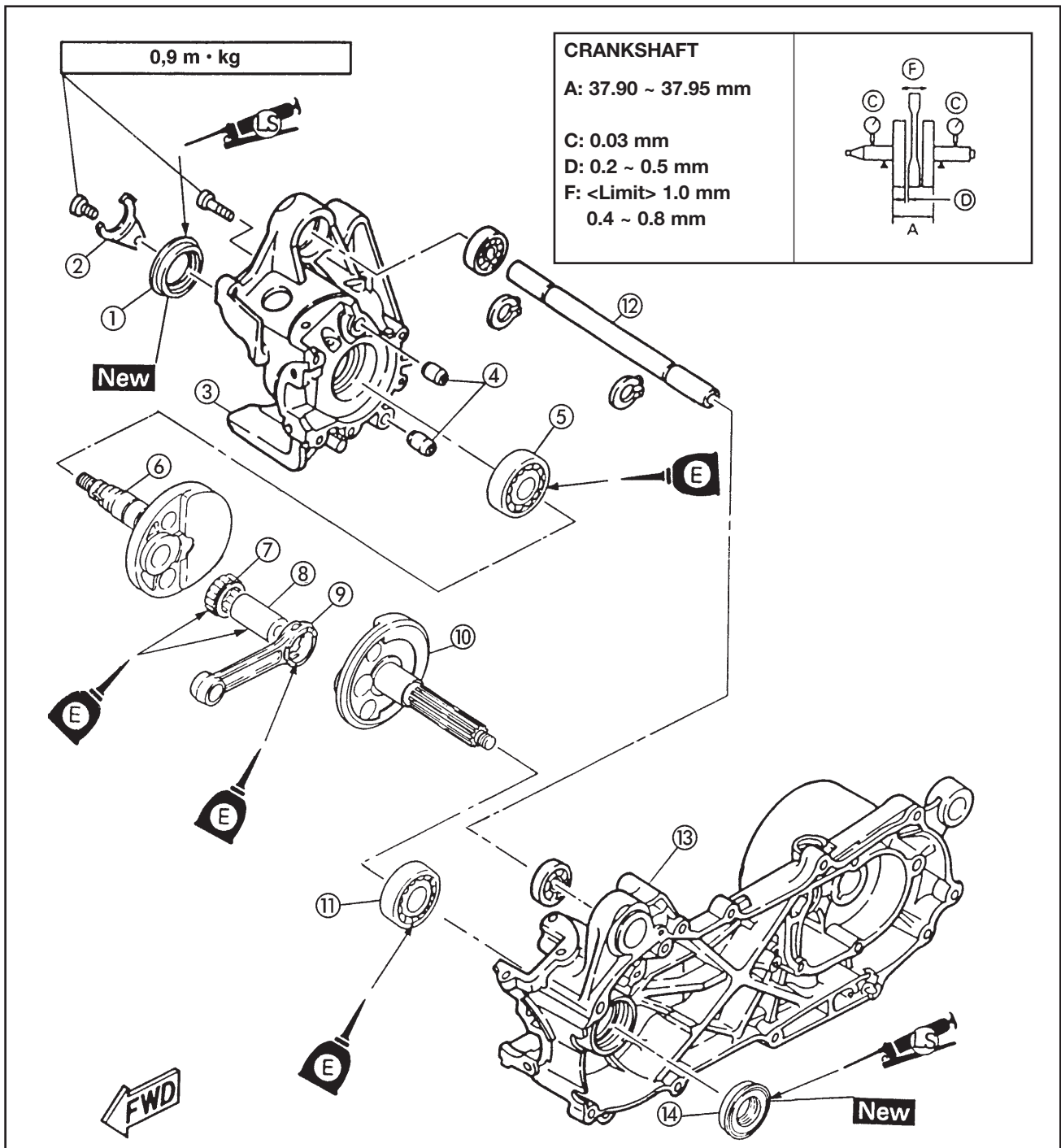

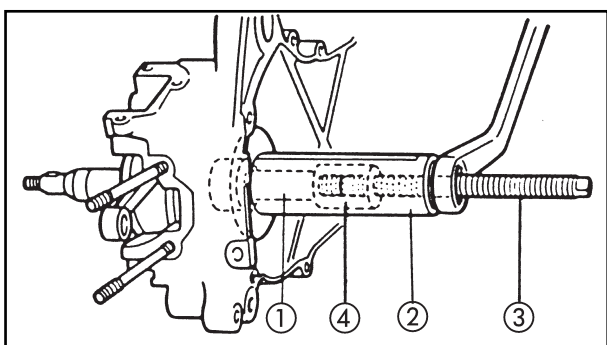

CRANKSHAFT AND CRANKCASE

- Place:
 - Crankshaft installation tool



Crankshaft installation tool:

- ①: 90890-01411
- ②: 90890-01274
- ③: 90890-01275
- ④: 90890-01277

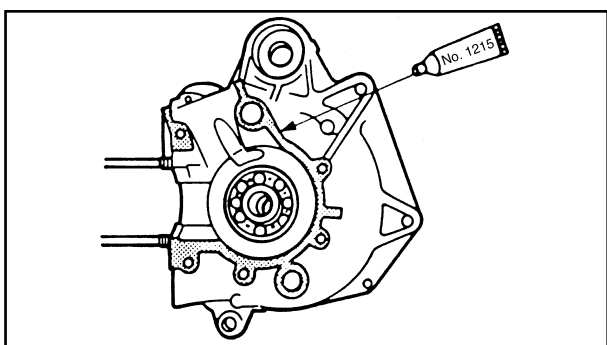

- Install:
 - Crankshaft
(in left crankcase)
- Install:
 - Centring device
 - Engine mounting spacer
- Apply:
 - Yamaha N.° 1215 adhesive on the corresponding surfaces of both halves of the crankcase



Yamaha N. 1215 adhesive: 90890-85505

- Place:
 - Crankshaft installation tool

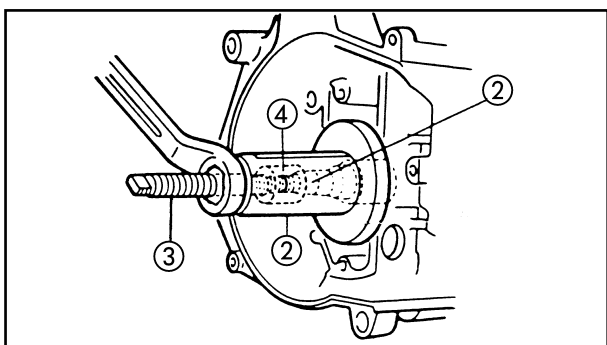

Crankshaft installation tool:

- ①: 90890-01411
- ②: 90890-01274
- ③: 90890-01275
- ④: 90890-01277

- Install:
 - Right crankcase
- Tighten:
 - Crankcase positioning screws

NOTE:

Tighten the crankcase positioning screws in stages, using a crossed method for tightening.

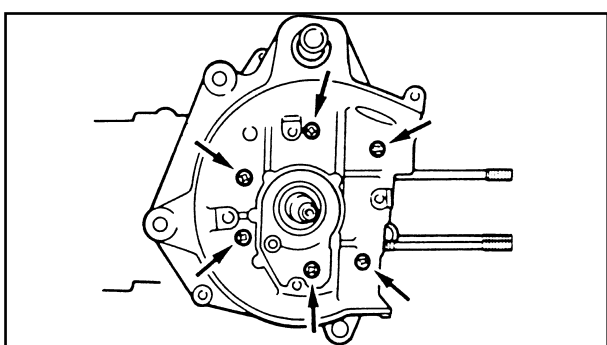

Crankcase screws 0.9 m • kg

- Check:
 - Rotation of crankshaft
Rough turning → Repair
- Install:
 - Oil seal catch plate ①

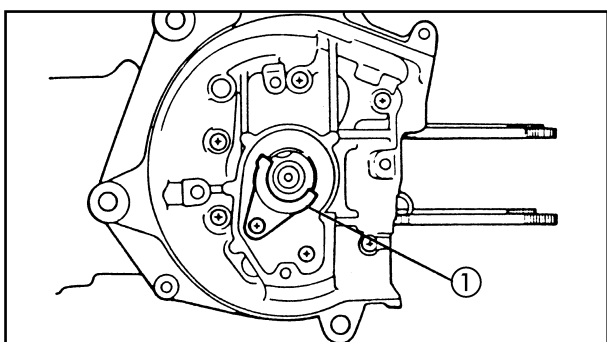

Screw (oil seal catch plate) 0.9 m • kg

ASSEMBLY AND ADJUSTMENT OF ENGINE

MOT



AUTOLUBRICATION PUMP AND MAGNETIC FLYWHEEL

- | | |
|-------------------|------------------------|
| ① Fan | ⑩ Oil outlet pipe |
| ② Flat washer | ⑪ Oil pipe |
| ③ Rotor assembly | ⑫ Bushing |
| ④ Charge coil | ⑬ Autolubrication pump |
| ⑤ Lighting coil | ⑭ O-ring |
| ⑥ Harnessing coil | ⑮ Elastic circlip |
| ⑦ Stator plate | ⑯ Oil pump drive gear |
| ⑧ Oil seal | ⑰ Pin |
| ⑨ Gasket | |

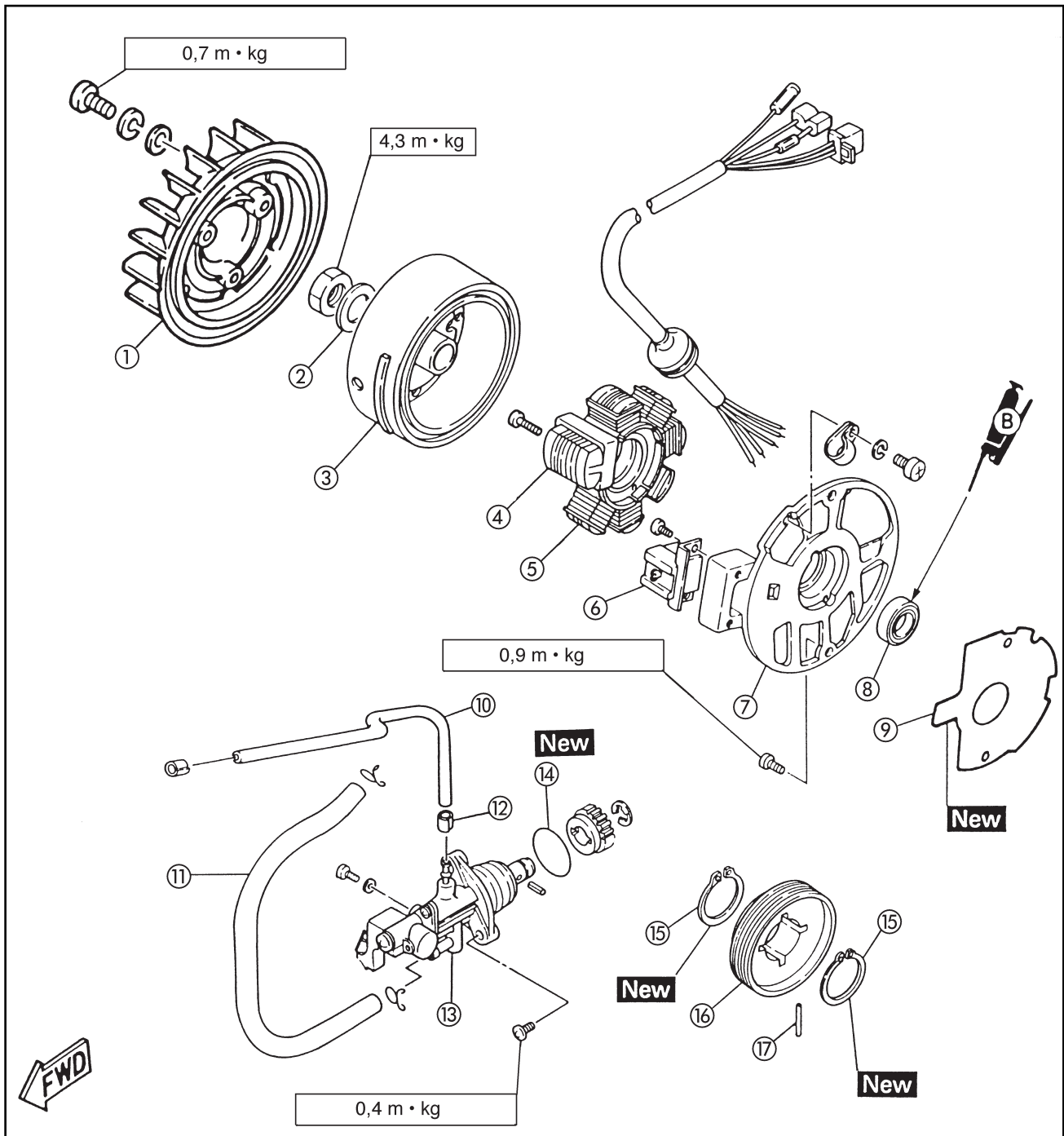

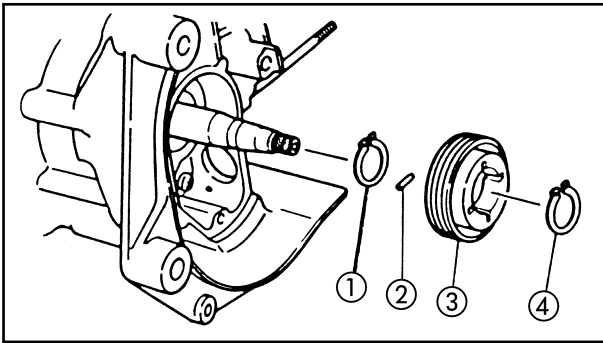

AUTOLUBRICATION PUMP

1. Install:
 - Elastic circlip ①
 - Pin ②
 - Pump drive gear ③
 - Elastic circlip ④

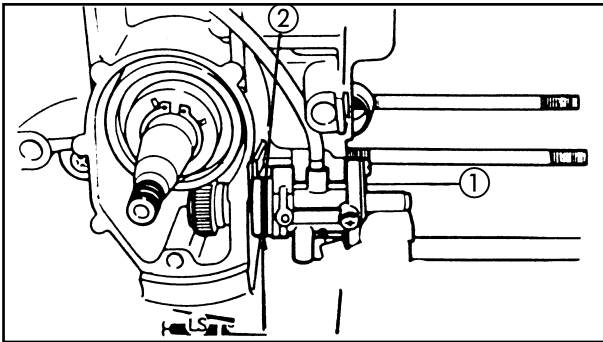

2. Apply:
 - Grease with lithium soap base (on the o-ring ②)
3. Install:
 - Autolubrication pump ①

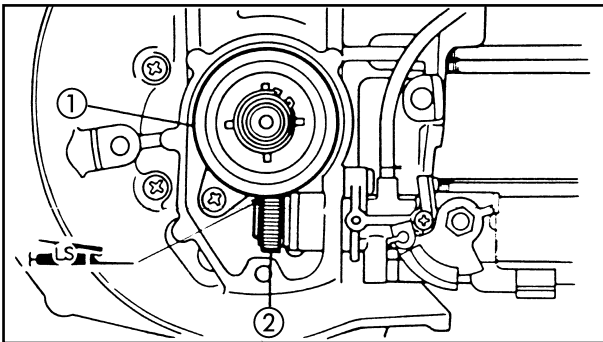
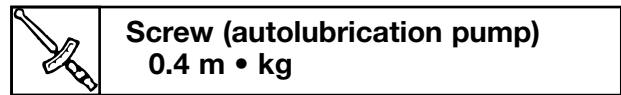

4. Apply:
 - Grease with lithium soap base (on the autolubrication pump gear ①, ②)

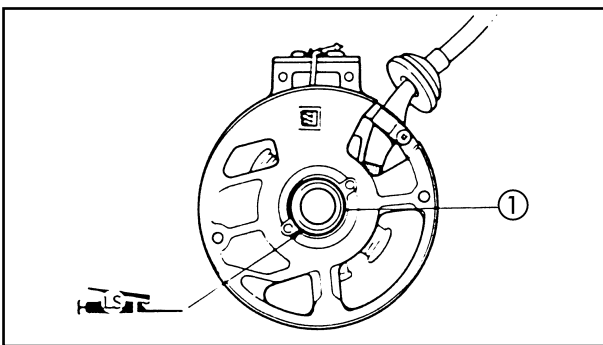

FLYWHEEL MAGNETO

1. Install:
 - Seal
2. Apply:
 - Grease with lithium soap base (on the oil reten ①)
3. Pass the wheel cable through the crankcase orifice.
4. Install:
 - Stator assembly



5. Install:
 - Key
 - Magnetic wheel
 - Flat washer
 - Nut



TRANSMISSION

- | | |
|-------------------------|-------------------------------|
| ① Circlip | ⑨ Secondary pulley wheel axle |
| ② Bearing | ⑩ Bearing |
| ③ Oil seal | ⑪ Centring device |
| ④ Drive axle | ⑫ Seal |
| ⑤ Bearing | ⑬ Transmission box cover |
| ⑥ Main axle | ⑭ Bearing |
| ⑦ Conical spring washer | ⑮ Oil seal |
| ⑧ Flat washer | |

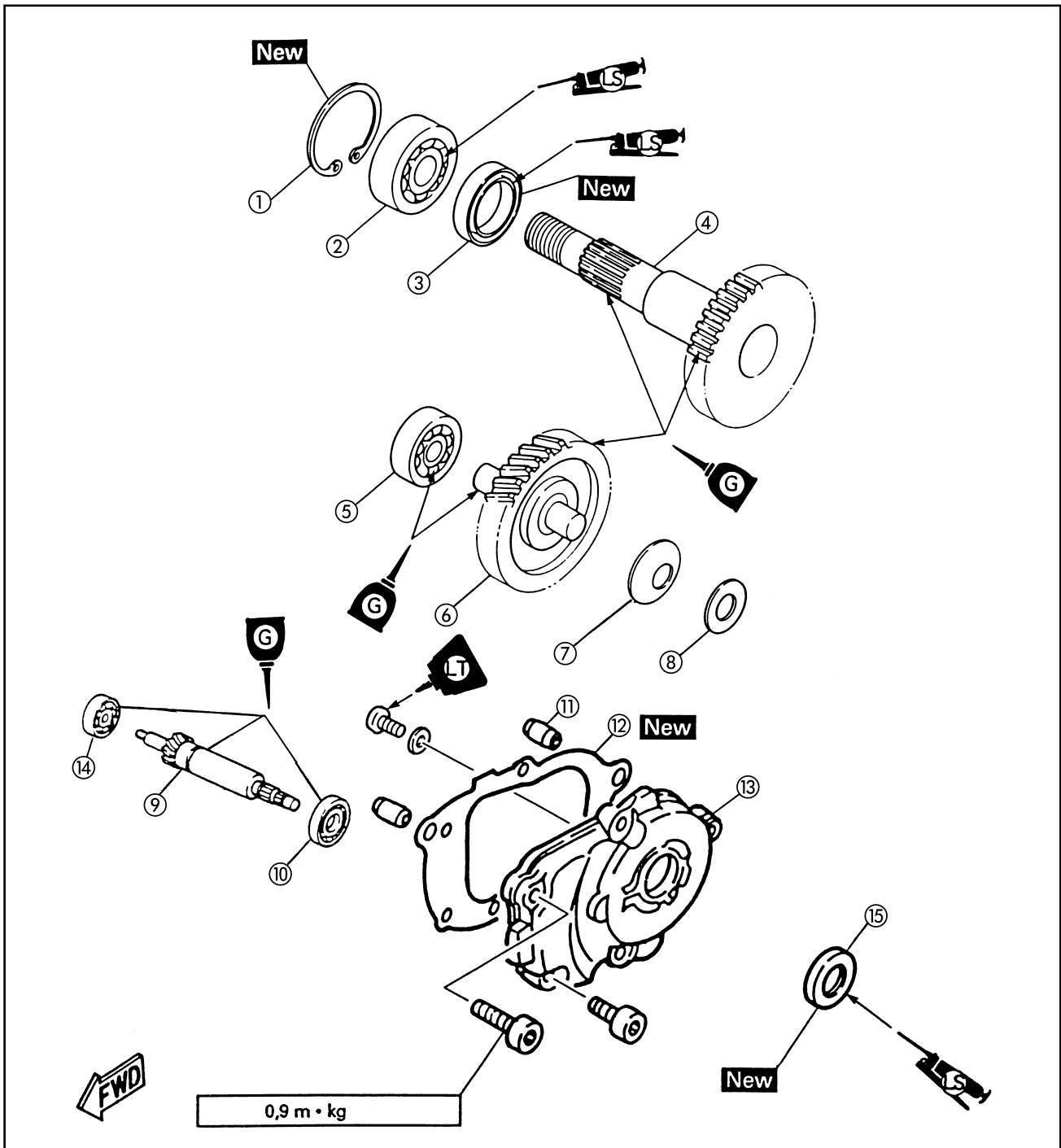

ASSEMBLY AND ADJUSTMENT OF ENGINE

MOT

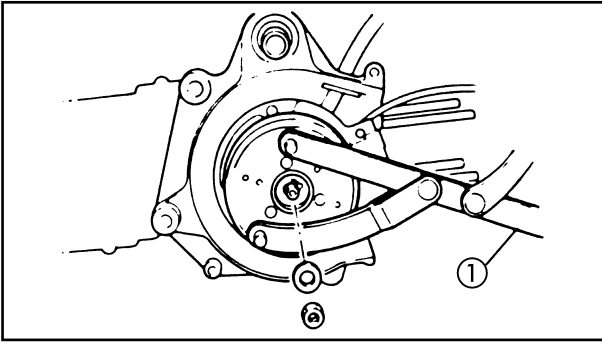

6. Tighten:
 - Nut (flywheel magneto)
 - Use the engine wheel support tool ①.



Engine wheel support tool
90890-01235



Flywheel nut
4.3 m • kg

TRANSMISSION

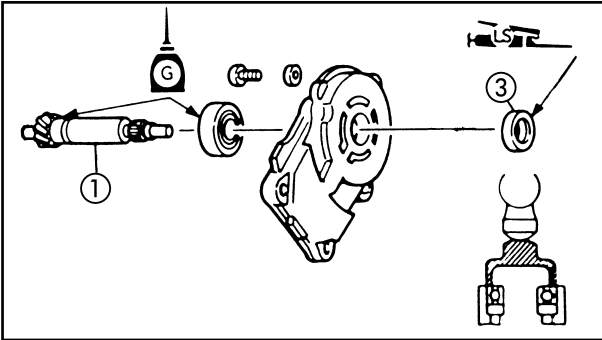

1. Apply:
 - SE engine oil type 10W30
(on the transmission box cover bearing)
2. Install:
 - Secondary pulley wheel axle ①
(on transmission box cover)
3. Install:
 - Circlip ②
 - Oil seal ③

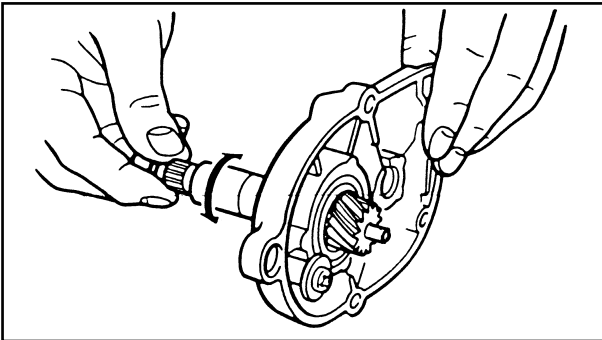

NOTE:

Apply grease with lithium soap based on the oil seal lips.

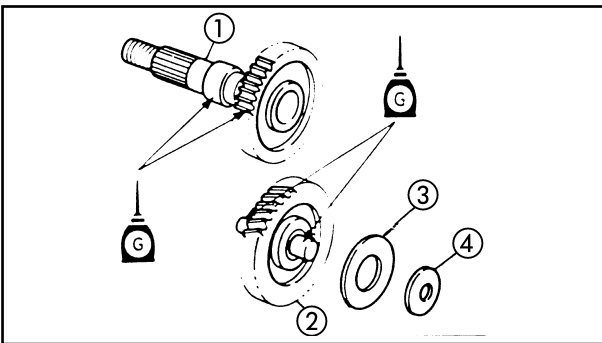

4. Check:
 - Rotation of secondary pulley wheel axle.
Rough rotation → Repair.
5. Apply:
 - SE type 10W30 engine oil
(on bearing of main axle and drive axle bearing)
6. Install:
 - Drive axle ①
 - Main axle ②
 - Conical spring washer ③
 - Flat washer ④

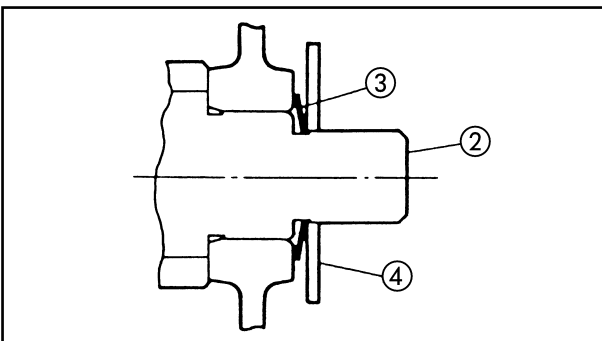

7. Install:
 - Gasket
 - Conical pins
 - Transmission box cover



Screw (box cover)
0.9 m • kg



STARTER SYSTEM

- | | |
|----------------------|---------------------|
| ① Bushing | ⑥ Axle |
| ② Bearing | ⑦ Flat washer |
| ③ Starter wheel gear | ⑧ Intermediate gear |
| ④ Starter clutch | ⑨ O-ring |
| ⑤ Plate | ⑩ Starter engine |

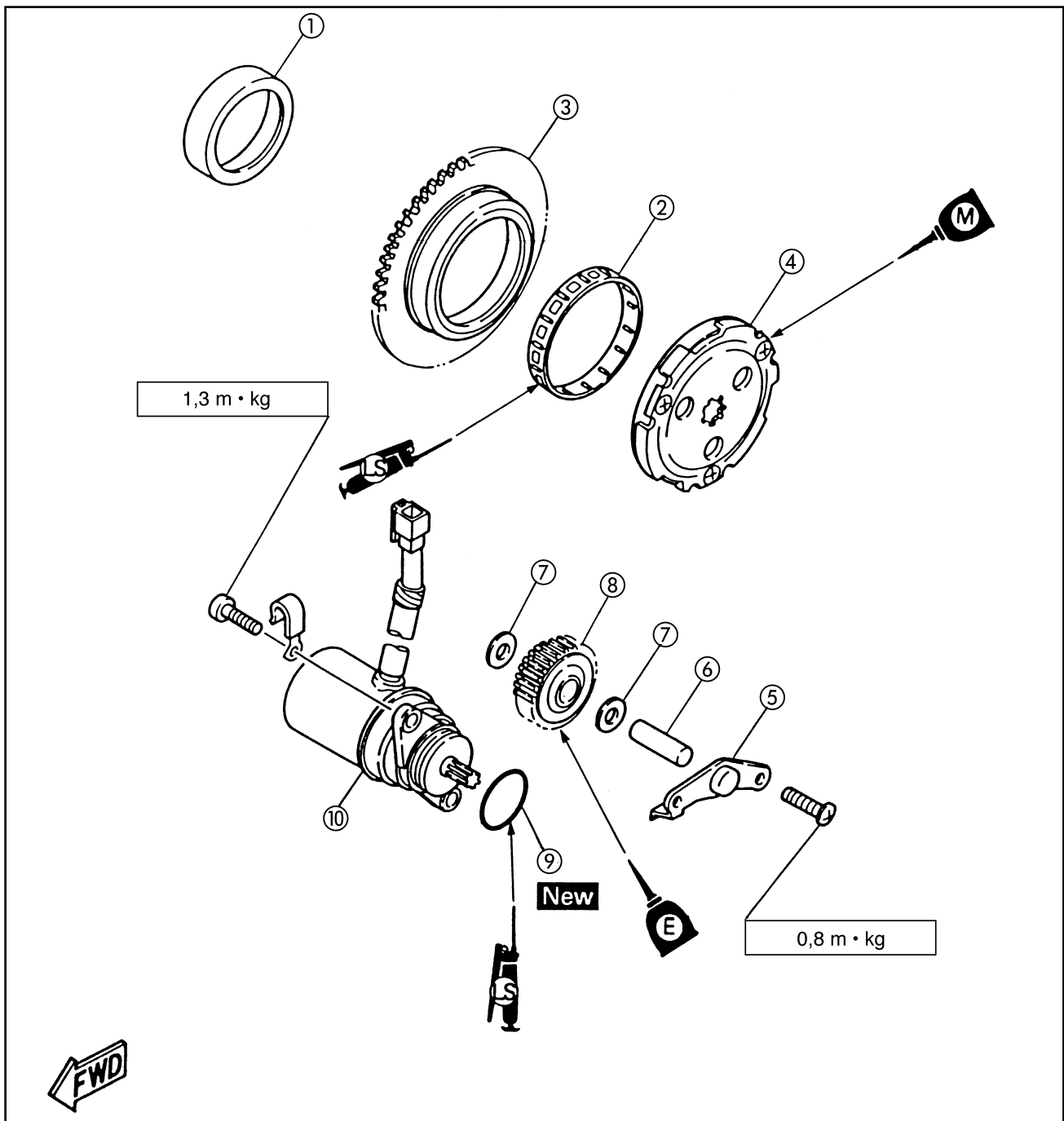

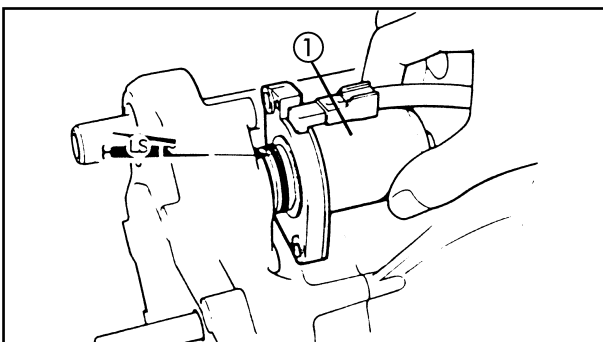
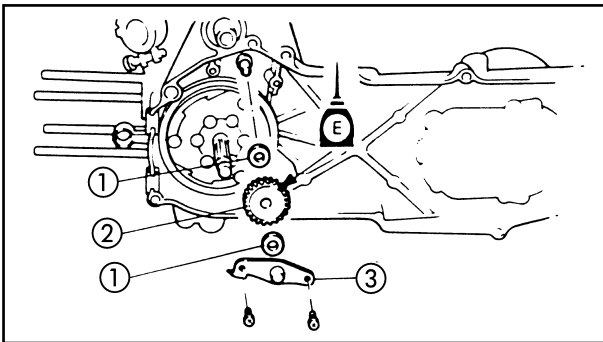
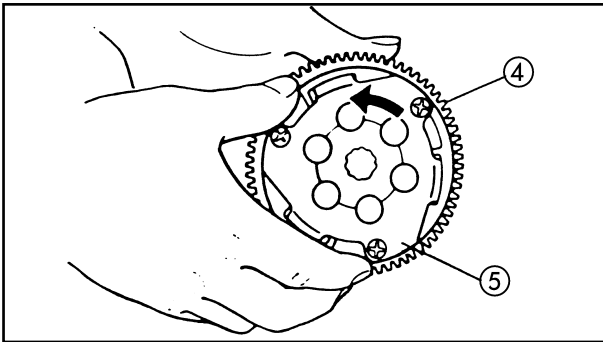
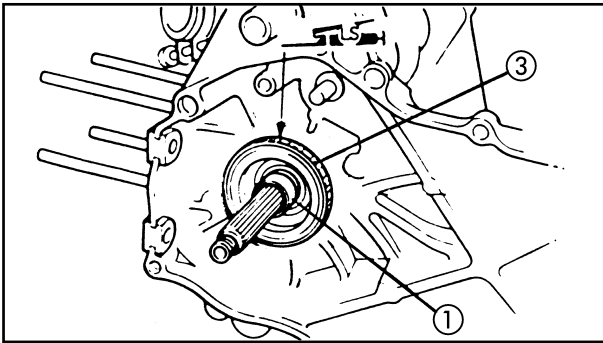

STARTER SYSTEM

1. Install:

- Bushing ①
- Bearing ③
- Starter wheel gear ④
- Starter clutch ⑤

NOTE: _____

- Apply grease with a lithium soap base on the bearing ③.
- Apply molybdenum disulphide oil on the pin (starter clutch) ⑤.

2. Install:

- Flat washer ①
- Intermediate gear ②
- Flat washer ①
- Plate ③ (intermediate gear)



Screw (intermediate gear plate)
0,8 m • kg

NOTE: _____

Apply engine oil on the intermediate gear ②.

3. Install:

- Starter motor ①



Starter motor bolts
1,3 m • kg

NOTE: _____

Apply grease with a lithium soap base on the o-ring of the starter motor.



SECONDARY AND PRIMARY PULLEY WHEEL

- | | | |
|-----------------|----------------------------------|--------------------------------|
| ① Nut | ⑨ Secondary sliding pulley wheel | ⑰ Shim |
| ② Clutch drum | ⑩ Trapezoidal belt | ⑱ Hub |
| ③ Clutch plate | ⑪ Guide pin | ⑲ Sliding primary pulley wheel |
| ④ Shoe spring | ⑫ Secondary fixed pulley wheel | ⑳ Rollers |
| ⑤ Clutch spring | ⑬ Conical washer | ㉑ Runner |
| ⑥ Spring seat | ⑭ One-way clutch | ㉒ Cam |
| ⑦ Oil seal | ⑮ Washer | ㉓ Washer |
| ⑧ O-ring | ⑯ Fixed primary pulley wheel | |
- *: Apply assembly lube

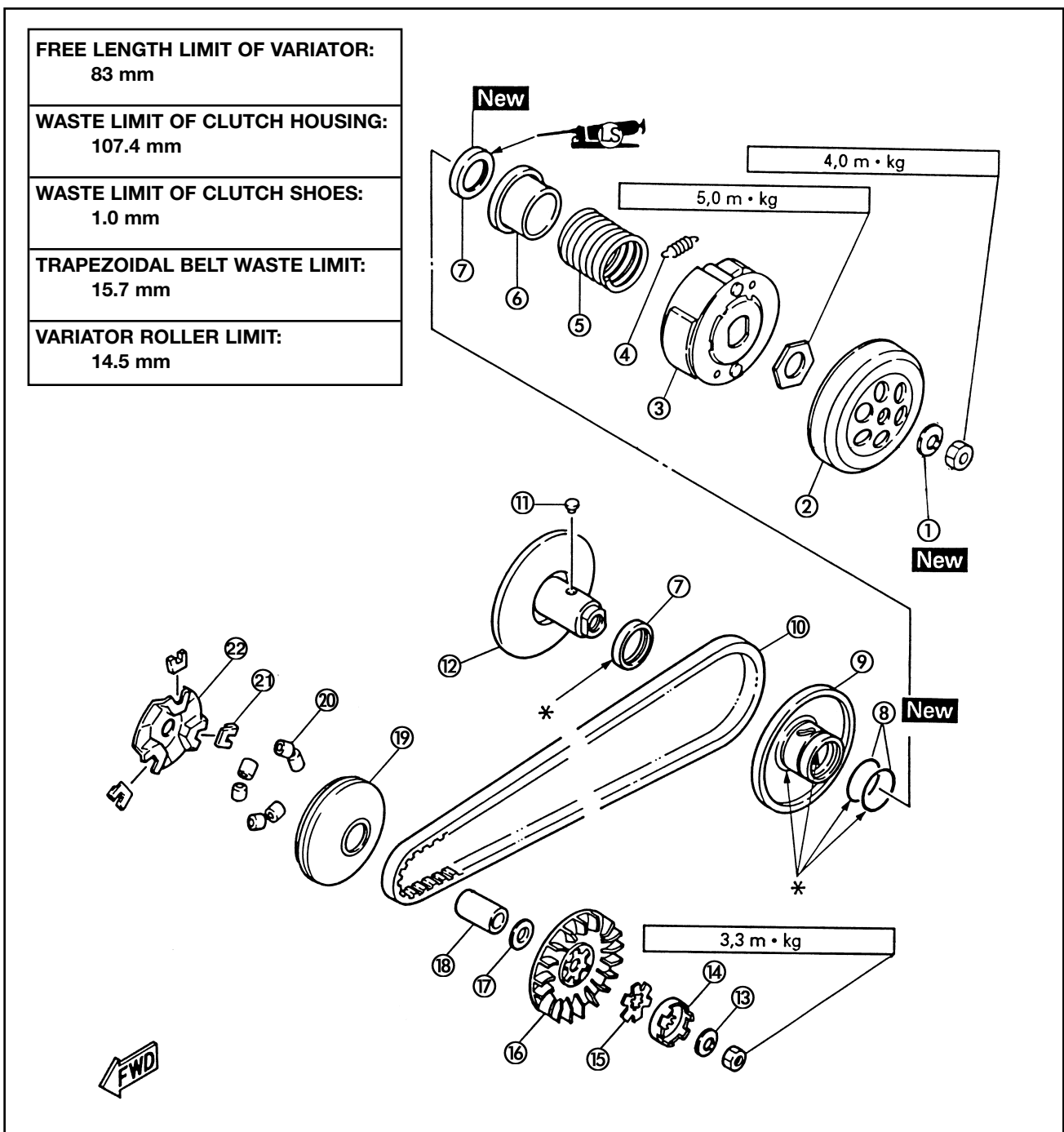



KICKSTART PEDAL

- ① Pedal axle
- ② Return spring
- ③ Bushing
- ④ Flat washer
- ⑤ Elastic retainer
- ⑥ Starter pedal
- ⑦ Spring
- ⑧ Pedal pinion gear

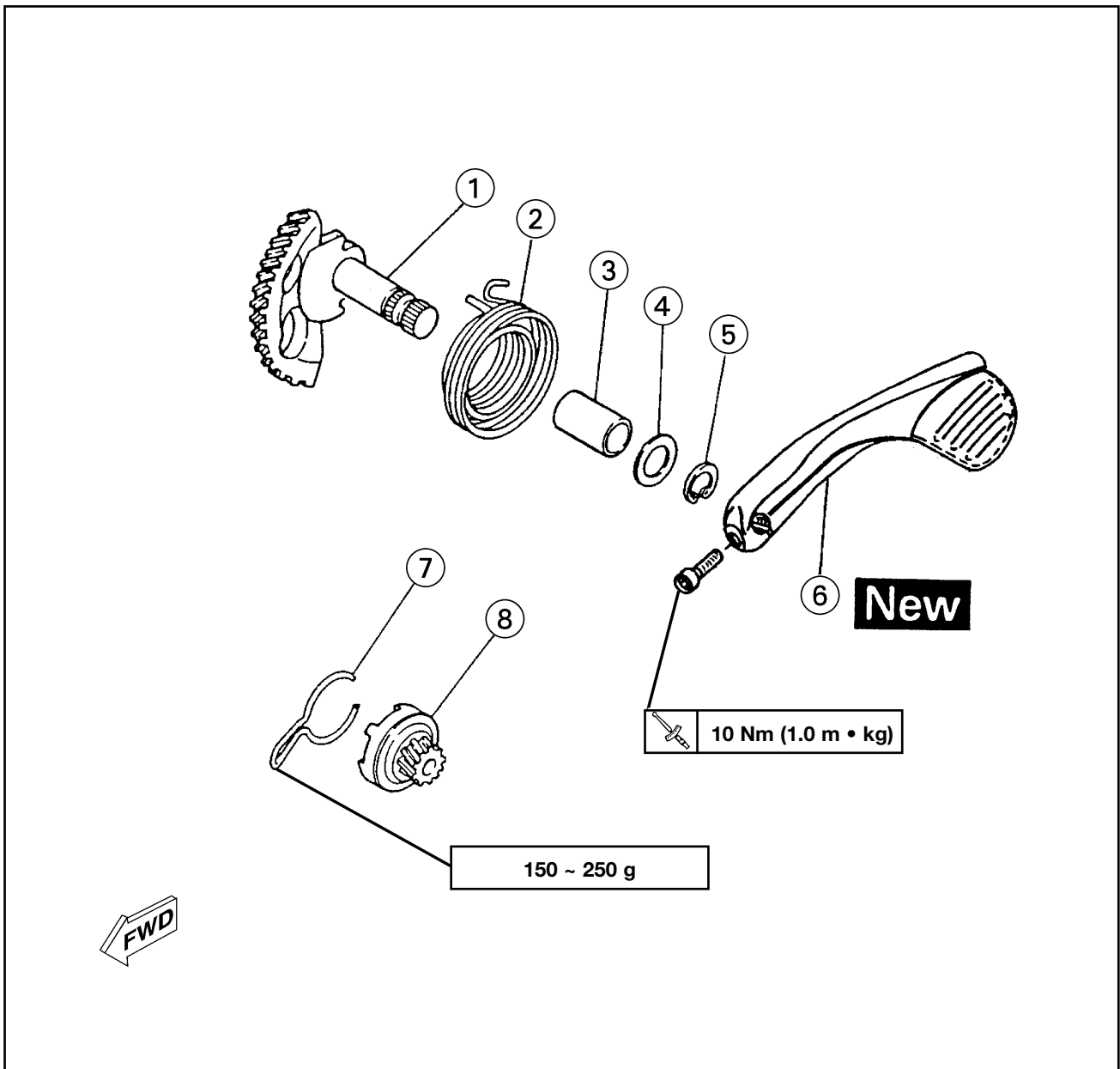

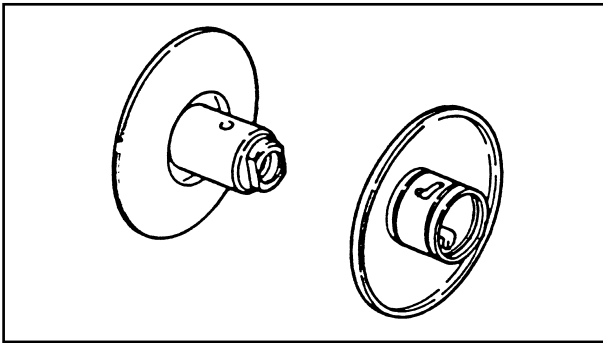

SECONDARY PULLEY WHEEL

When assembling the secondary pulley wheel, reverse the disassembly procedure. Remember the following points:

1. Apply:
 - Assembly grease
(in the sliding/fixed pulley wheel)

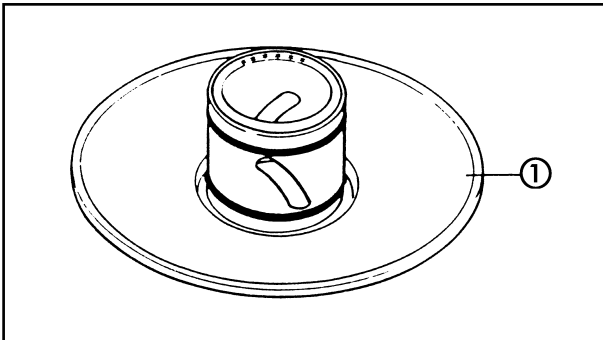

2. Install:
 - Sliding pulley wheel ①

NOTE: _____

Take care that the lips of the oil seals do not turn when the pulley wheel is installed.

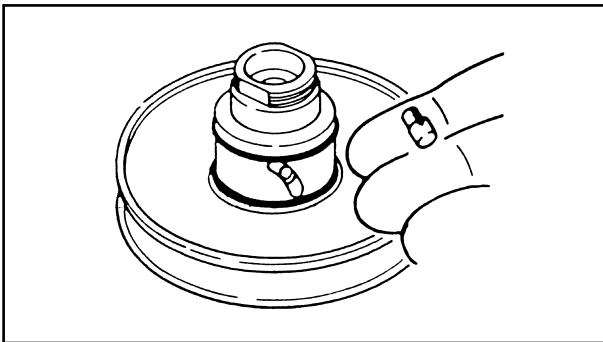

3. Apply:
 - Assembly grease
(on the torsion cam grooves and o-rings)
4. Check:
 - Sliding pulley wheel.
Faulty operation → Repair.

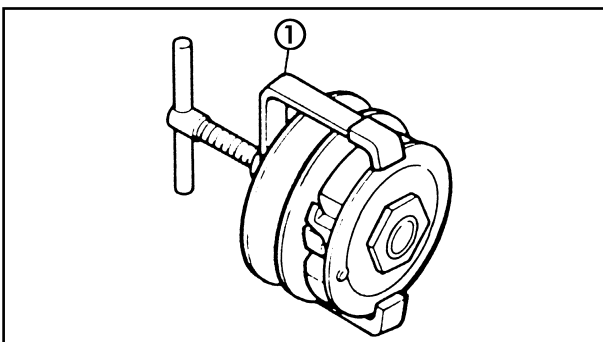

5. Install:
 - Clutch positioning bolt
Use the clutch spring compressor ①



Clutch spring compressor
90890-01337

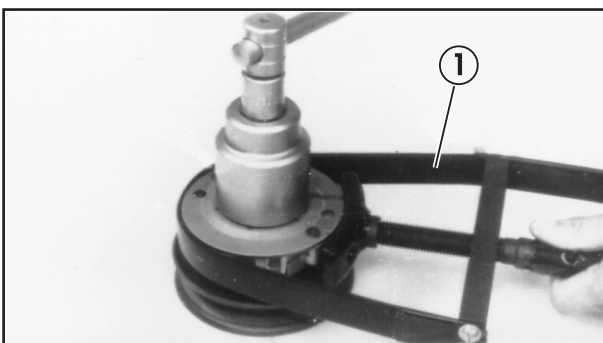

6. Tighten:
 - Clutch positioning nut
Use the pulley wheel clamp ①
Spanner (41 MM).



Pulley wheel clamp
90890-01701



5.0 m • kg

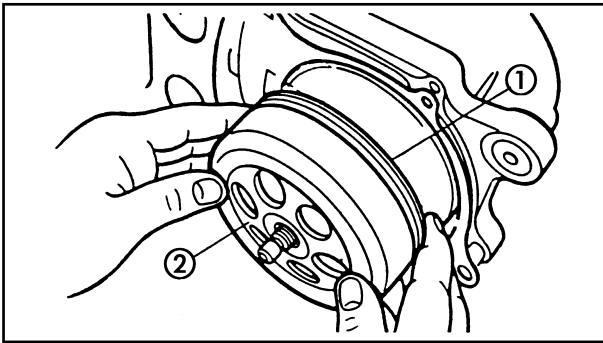

7. Install:
 - Conical pin
 - Crankcase cover seal
 - Secondary pulley wheel assembly ①
 - Clutch drum ②

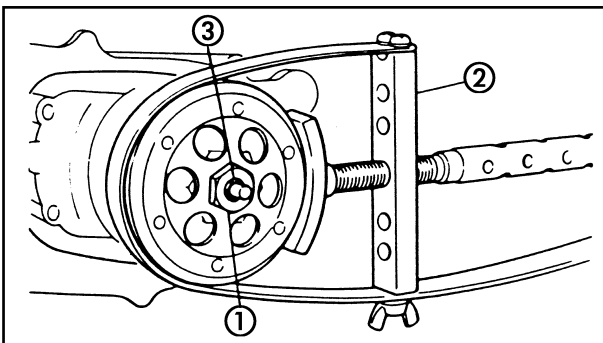

8. Tighten:
 - Nut ① (secondary pulley wheel)
 - Use the pulley wheel support ②

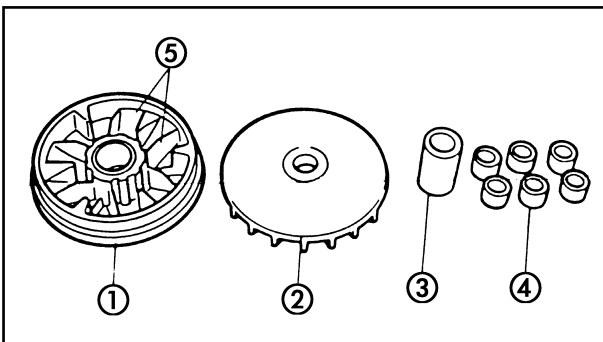
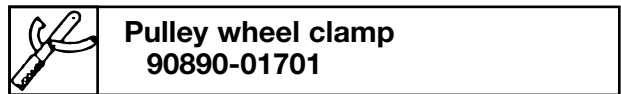

9. Install
 - O-ring ③

PRIMARY PULLEY WHEEL

1. Clean:
 - Surface of primary sliding pulley wheel ①
 - Surface of primary fixed pulley wheel ②
 - Hubs ③
 - Rollers ④
 - Roller races ⑤

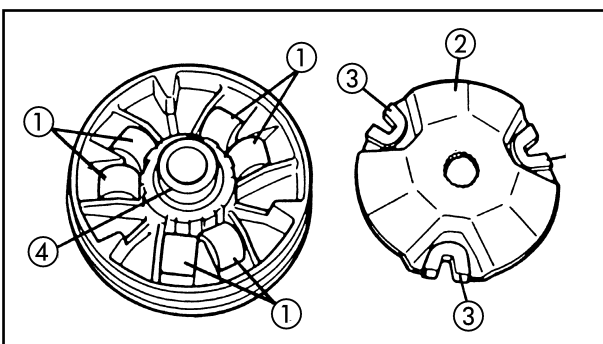

2. Install:
 - Counterbalance ①
 - Race ②
 - Runner ③
 - Hub ④
3. Check:
 - Operation of race Rough operation → Repair.

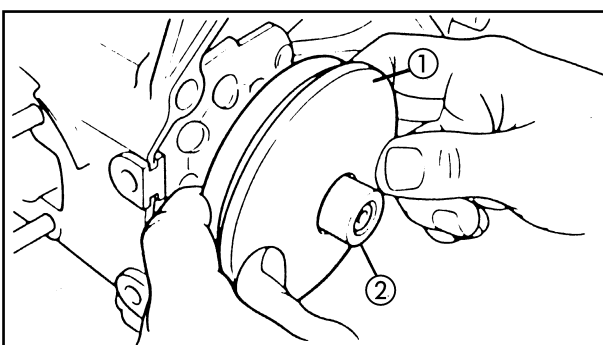

4. Install:
 - Primary pulley wheel assembly ①
 - Hub ②
5. Install:
 - Trapezoidal belt

NOTE: _____
 The trapezoidal belt should be installed with the arrow facing towards the front.

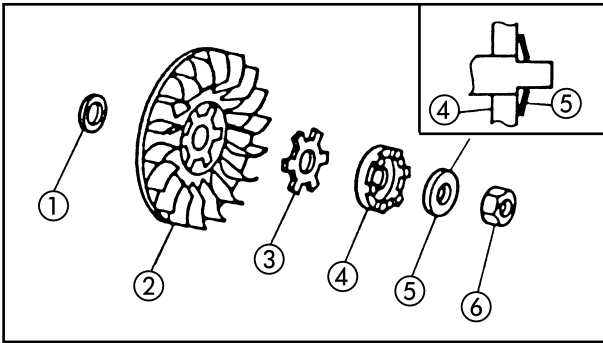

6. Install:
- Shim ①
 - Primary fixed pulley wheel ②
 - Washer ③
 - One-way clutch ④
 - Conical spring washer ⑤
 - Nut ⑥

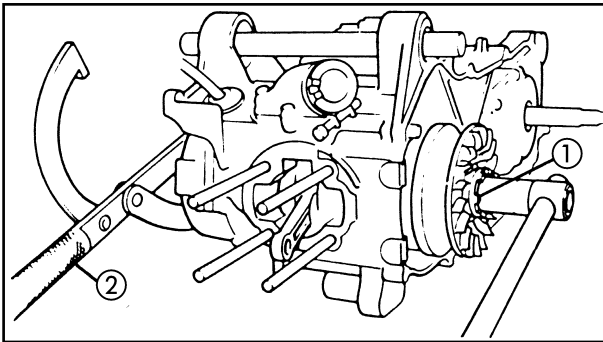

7. Tighten:
- Nut ① (primary pulley wheel)



NOTE:

When the nut is tightened (primary pulley wheel), support the magnetic flywheel using the engine wheel support tool ②

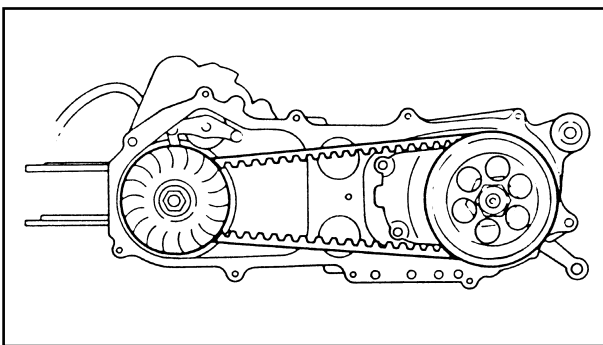
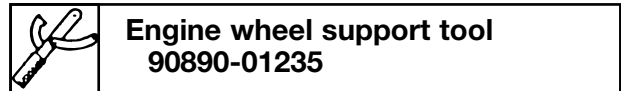

8. Adjust:
- Trapezoidal belt
Tense the trapezoidal belt by turning the primary pulley wheel several times

9. Install:
- Fan

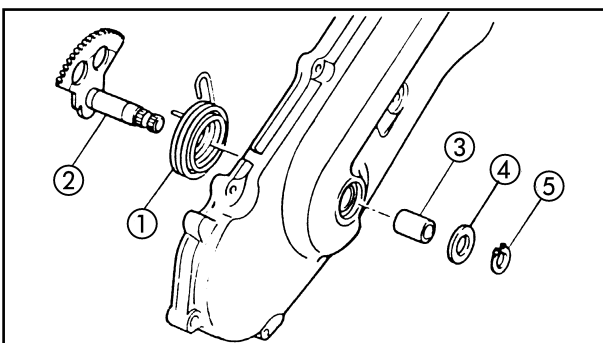
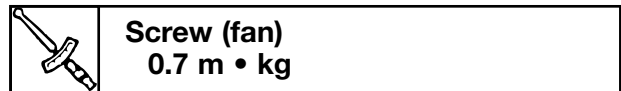

KICKSTART PEDAL

1. Install:
- Return spring ①
 - Pedal axle ②
 - Bushing ③
 - Flat washer ④
 - Elastic circlip ⑤

ASSEMBLY AND ADJUSTMENT OF ENGINE

MOT

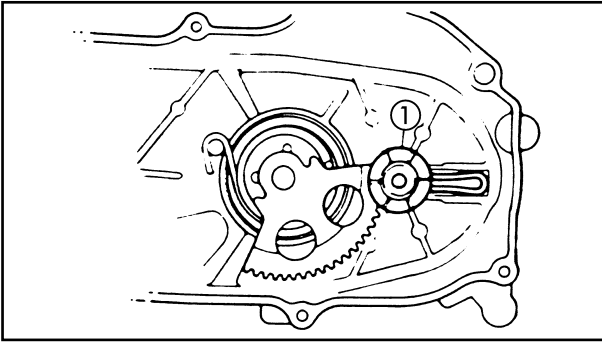

2. Hook on:
 - Return spring (on pedal gear and hub)
3. Install:
 - Pedal pinion gear ①

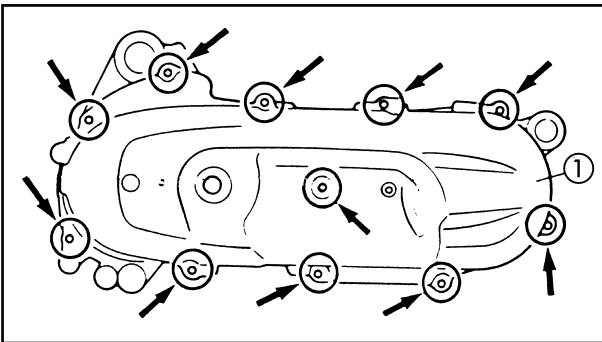

4. Install:
 - Crankcase cover ①



Screw (crankcase cover)
7 Nm (0.7 m • kg)

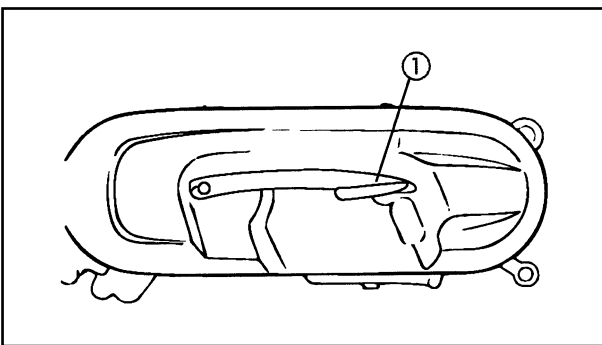

5. Install:
 - Kickstart pedal ①



Kickstart pedal
0.9 m • kg



PISTON, CYLINDER AND CYLINDER HEAD

- | | |
|------------------------|-----------------|
| ① Carburettor gasket | ⑦ Cylinder seal |
| ② Reed valve | ⑧ Piston rings |
| ③ Gasket | ⑨ Piston |
| ④ Cylinder head | ⑩ Piston pin |
| ⑤ Cylinder head gasket | ⑪ Circlips |
| ⑥ Cylinder | ⑫ Bearing |

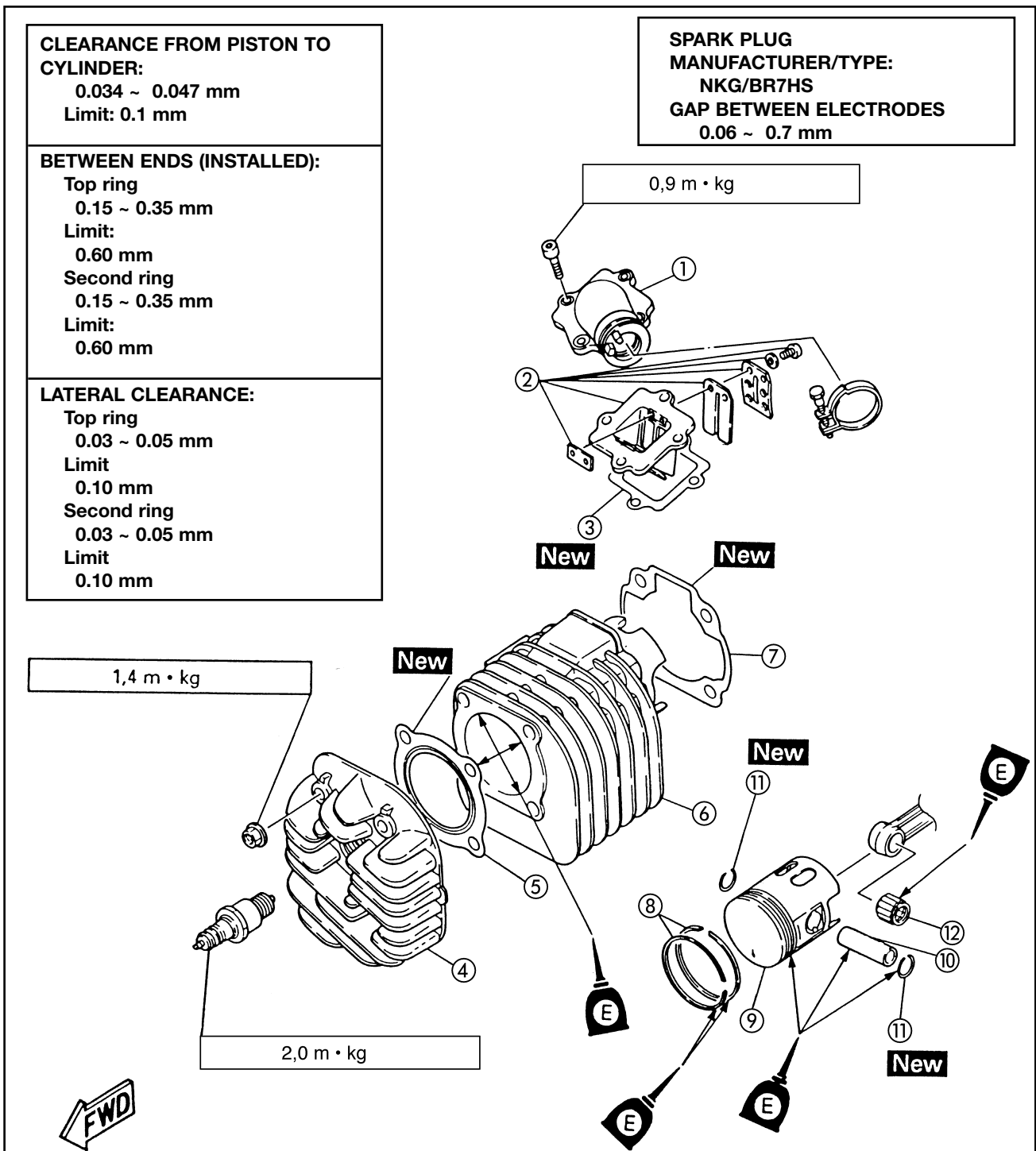

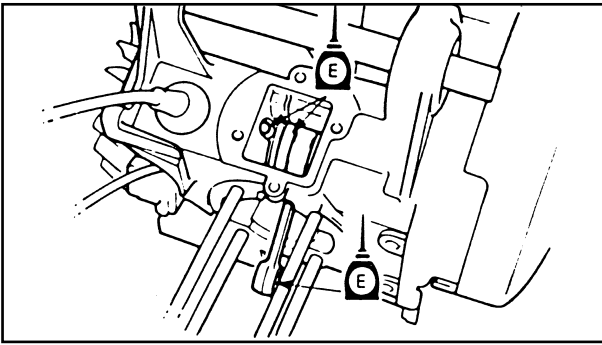

PISTON AND PISTON PIN

1. Apply:
 - Engine oil
(in the crankshaft bearing, big end bearing, small end bearing, piston pin, piston ring grooves and piston skirt areas.)
2. Install:
 - Reed valve gasket
 - Reed valve ①
 - Carburettor gasket ②

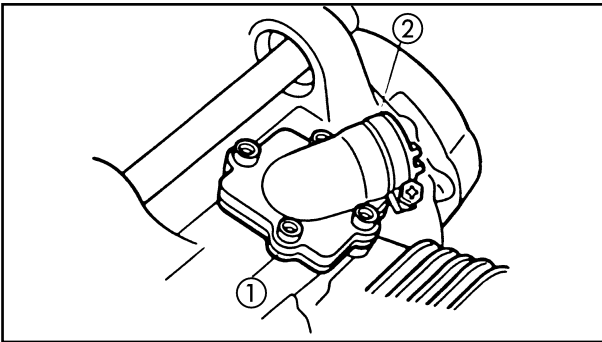

Carburettor gasket
0.9 m • kg

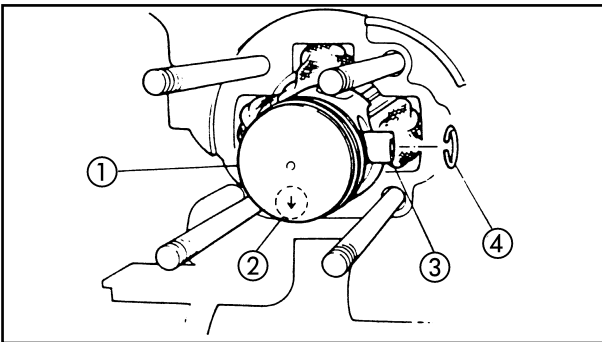

3. Install:
 - Small end bearing
 - Piston ①
 - Piston pin ③
 - Piston circlips ④

NOTE:

- The arrow ② of the piston should point to the exhaust side.
- Before installing the piston circlip, cover the crankcase with a towel or clean cloth so that the circlip and other materials do not accidentally fall into the crankcase.
- Always use new piston circlips.

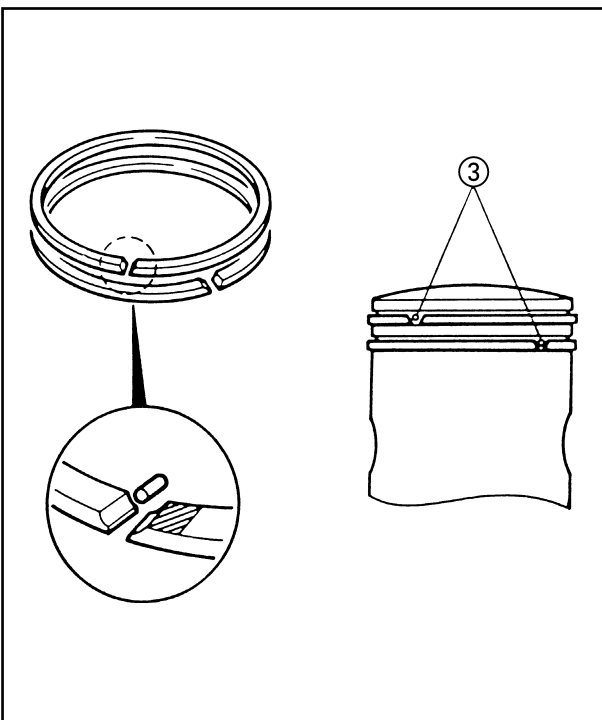

CYLINDER AND CYLINDER HEAD

1. Install:
 - Cylinder gasket (Use a new gasket)
2. Check:
 - Piston rings

NOTE:

- Ensure that the ends of the rings are correctly coupled around the centring devices ③ on the piston grooves.
- Check that the manufacturers symbols or numbers printed on the rings are on the upper side of same.

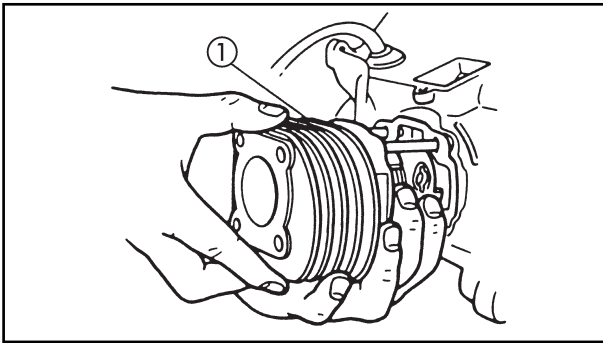

3. Install:
- Cylinder ①

NOTE:

Install the cylinder with one hand while compressing the piston rings with the other.

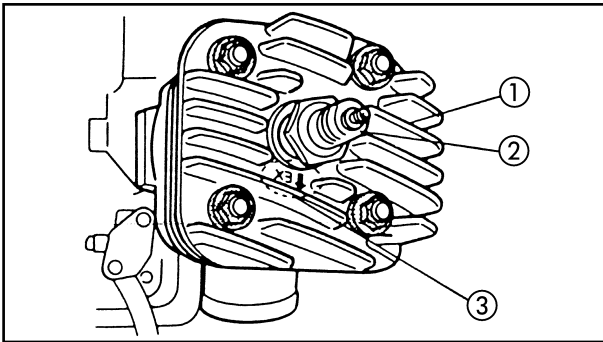

4. Install:
- Cylinder head gasket (new gasket)
5. Install:
- Cylinder head ①
 - Spark plug ②
 - Air protector

NOTE:

- The arrow ③ “EX” from the cylinder head should point to the exhaust side.
- Tighten the cylinder head positioning nuts in several steps, using a *cris-cross pattern*



Cylinder head positioning screws
 1.4 m • kg
 spark plug
 2.0 m • kg

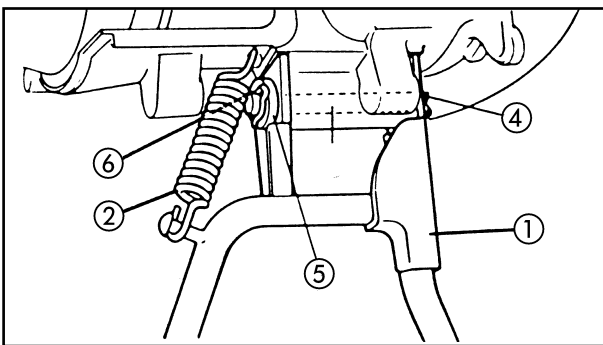

6. Install:
- Central stand ①
 - Spring ②
 - Axle ③
 - Clasp ④
 - Rubber washer ⑤
 - Strap loop ⑥

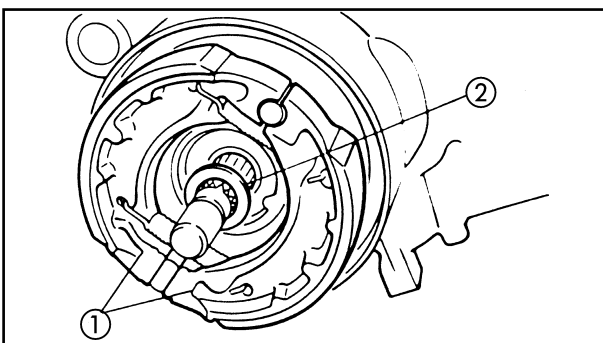

7. Install:
- Brake shoes ①
 - Flat washer ②
 - Rear wheel

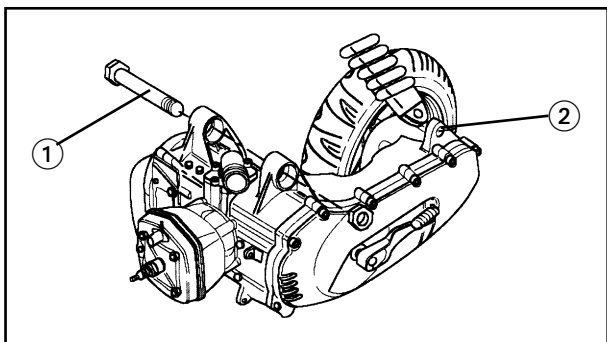

ASSEMBLY OF ENGINE

When the engine is being assembled, reverse the removal procedure

1. Install:
 - Engine assembly bolt ①
 - Rear shock absorber bolt ② (lower)



Engine assembly bolt

8.4 m • kg

Rear shock absorber bolt (lower)

1.8 m • kg

2. Install:
 - Carburettor
 - Oil supply pipe
 - Fuel pipes
 - Air filter box assembly

NOTE:

- Align the projection of the carburettor with the projections of the head
- Before installing the oil supply pipe, fill it with oil.

3. Install:
 - Oil pipe
 - Oil supply pipe

NOTE:

Pass the oil supply pipe and the oil pipe through as shown.

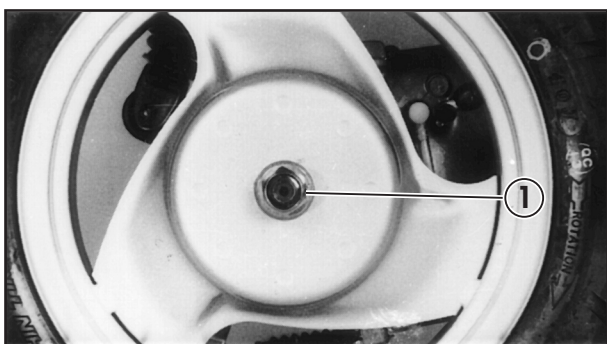

4. Bleed the air:
 - Autolubrication pump

Consult chapter 3, section – “BLEEDING OF AIR FROM THE AUTOLUBRICATION PUMP”.

5. Tighten:
 - Rear wheel axle nut ①

NOTE:

When the rear wheel axle nut is tightened, apply the rear brake.



rear wheel axle bolt

12.5 m • kg

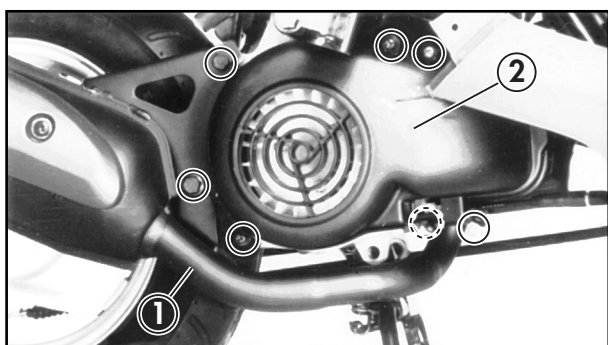

6. Install:
- Silencer ①
 - Fan cover ②

	Bolt (silencer)
	2.6 m • kg
	Bolt (exhaust pipe)
	0.9 m • kg

7. Apply:
- Transmission oil.
See chapter 3 section - “CHANGING TRANSMISSION OIL”.
8. Adjust:
- Free play of brake levers.
See chapter 3, section - “ADJUSTMENT OF FREE PLAY OF FRONT/REAR BRAKE LEVER”.
 - Free play of accelerator cable See section “ADJUSTMENT OF FREE PLAY OF ACCELERATOR CABLE”.

9. Install:
- Helmet carrier
 - Overflow bowl
 - Footrest
 - Rear bodywork
 - Rear cover
- Follow the reverse process to the removal procedure.

10. Install:
- Battery in its footrest housing

11. Connect:
- Battery cables

<p>Positive cable + to positive terminal + of battery</p> <p>Negative cable – to negative terminal – of battery</p>

12. Place:
- Front cover

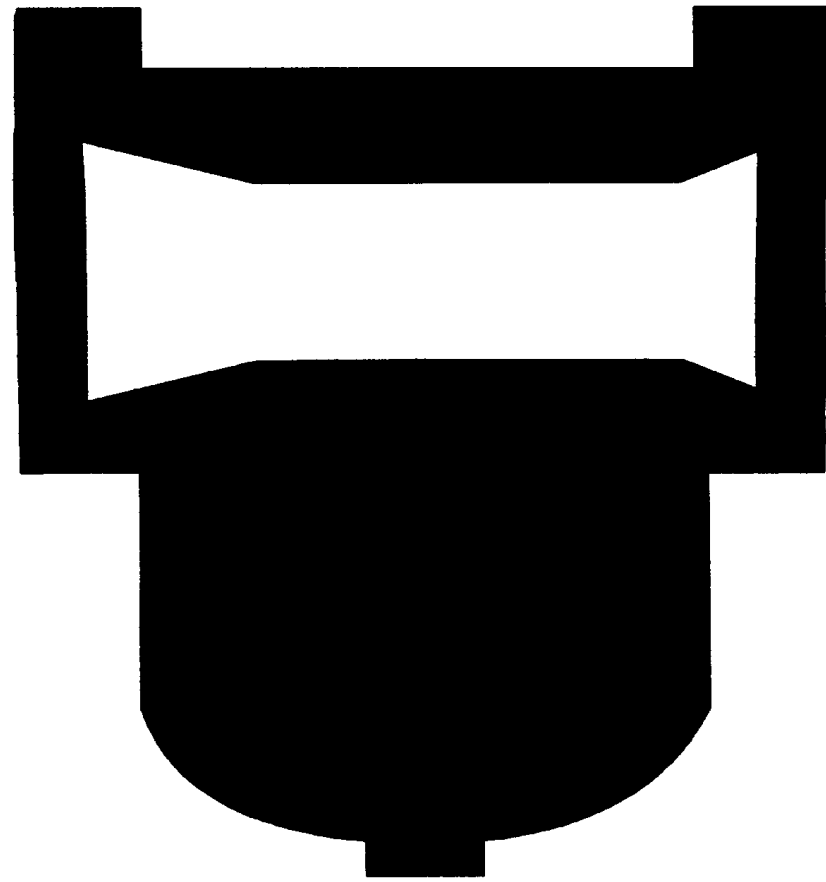

CARB

5



CHAPTER 5 CARBURETOR

CARBURETOR	5-1
REMOVING THE CARBURETOR	5-2
DISASSEMBLING THE CARBURETOR	5-2
CHECKING THE CARBURETOR	5-3
ASSEMBLING THE CARBURETOR	5-5
CHECKING THE AUTOCHOKE UNIT	5-6
INSTALLING THE CARBURETOR.....	5-7
FUEL COCK	5-7
CHECKING THE FUEL COCK	5-7
REED VALVE	5-8
REMOVING THE REED VALVE	5-8
CHECKING THE REED VALVE	5-8
INSTALLING THE REED VALVE.....	5-9



EAS00480

CARBURETOR

CARBURETOR

- ① Throttle valve spring
- ② Spring catch
- ③ Throttle valve
- ④ Jet needle
- ⑤ Pilot air screw
- ⑥ Throttle stop screw
- ⑦ Needle jet
- ⑧ Main jet
- ⑨ Pilot jet
- ⑩ Float
- ⑪ Float gasket
- ⑫ Drain screw
- ⑬ Needle valve
- ⑭ Float chamber
- ⑮ Autochoke unit

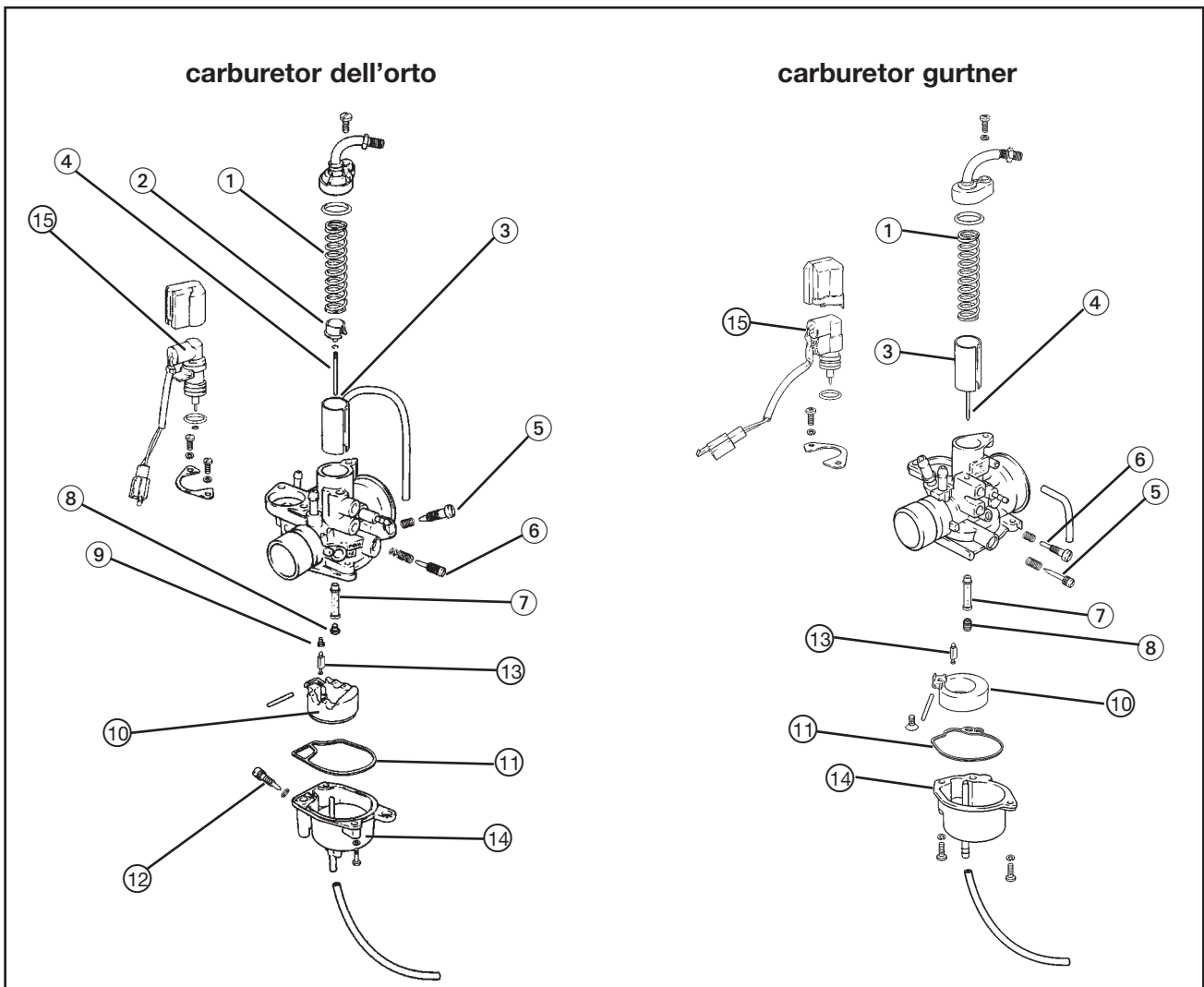

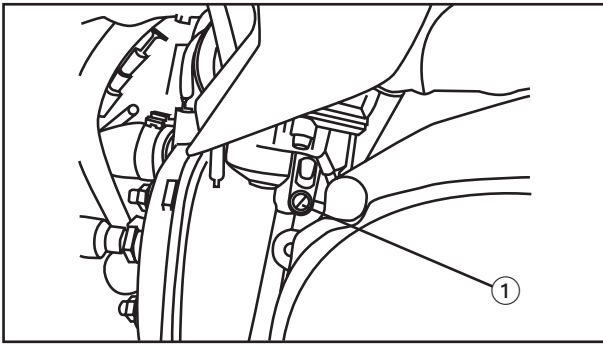

REMOVING THE CARBURETOR

1. Remove:
 - air filter box
 - helmet box
 Refer to "REAR BODYWORK, MUD-GUARD" in chapter 3
2. Drain:
 - fuel (from drain screw ①)

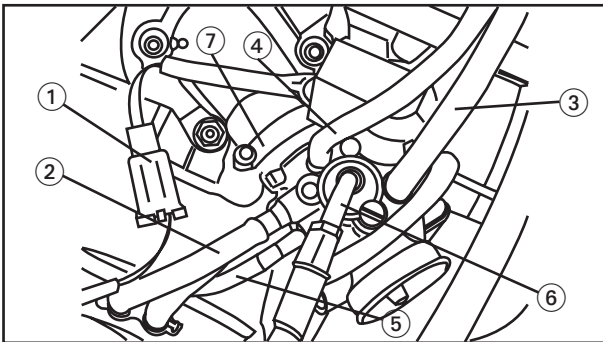

3. Disconnect:
 - autochoke lead coupler ①
 - fuel hose ③
 - vacuum hose ④
 - oil delivery hose ⑤
 - throttle cable (with throttle valve) ⑥
 - clamp (fixing clip) ⑦

4. Remove:
 - carburetor

DISASSEMBLING THE CARBURETOR

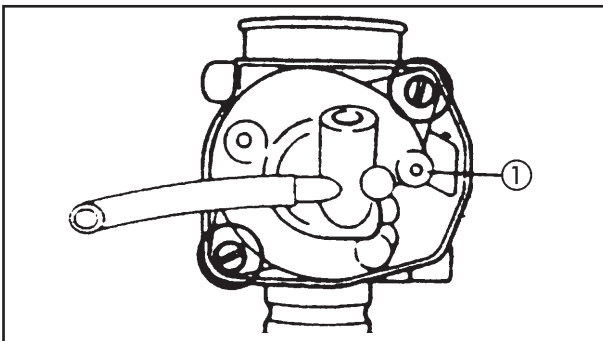

1. Remove:
 - float chamber ①

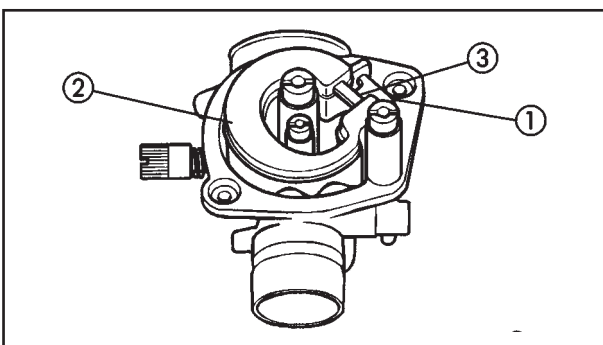

2. Remove:
 - float pin ①
 - float ②
 - needle valve ③

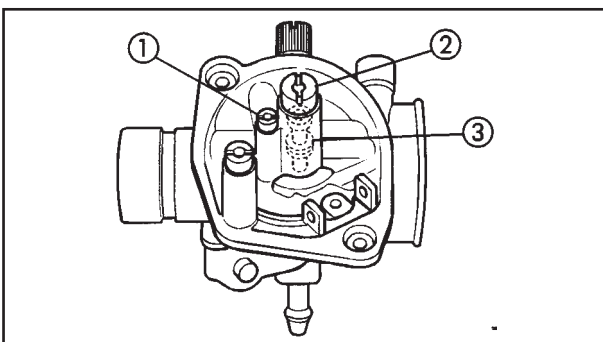

3. Remove:
 - pilot jet ①
 - main jet ②
 - needle jet ③

CARBURETOR

CARB

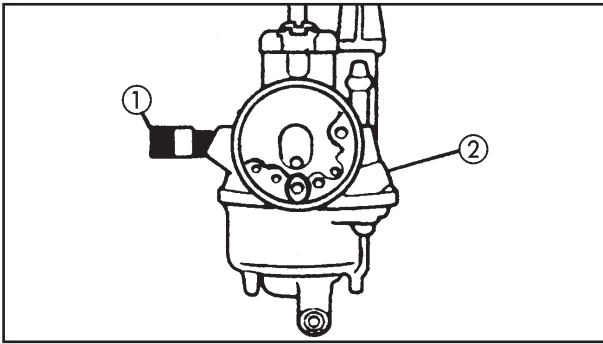

4. Remove:
- throttle stop screw ① (with spring, washer and o-ring)
 - pilot air screw ② (with spring)

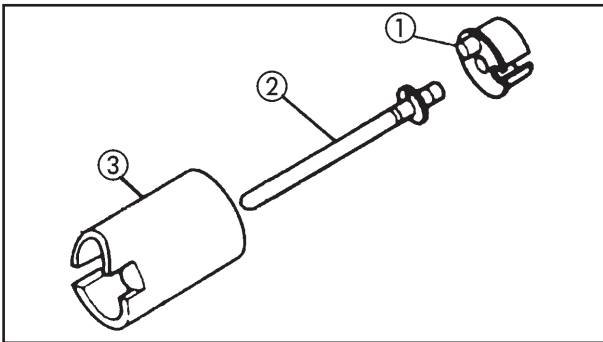

5. Remove:
- spring seat ①
 - jet needle ②
 - throttle valve ③
 - throttle valve spring

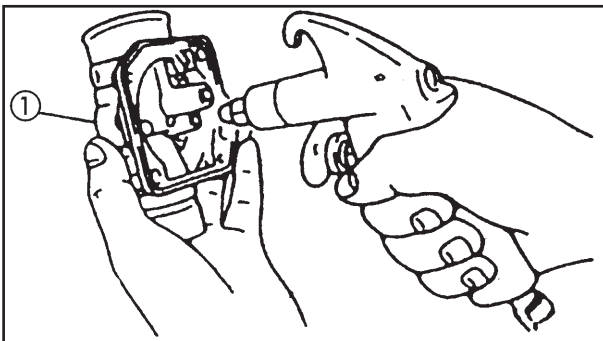

EAS00485

CHECKING THE CARBURETOR

1. Check:
- carburetor body ①
Dirty → Clean

NOTE:

For cleaning, use a petrol based solvent. Clean the pipes and jets with compressed air

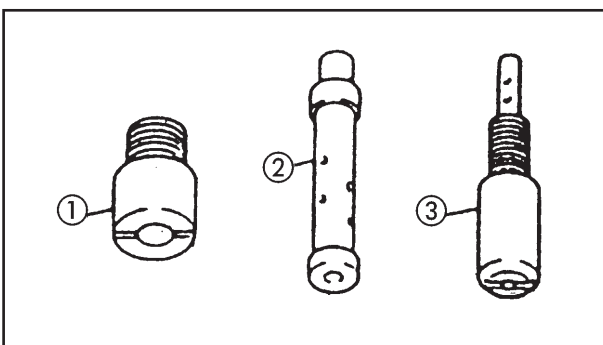

2. Check:
- main jet ①
 - needle jet ②
 - pilot jet ③
Dirty → Clean

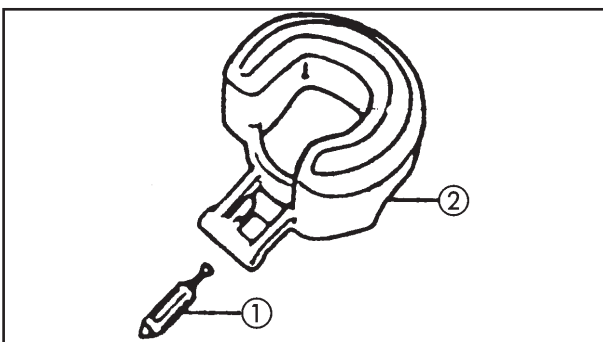

3. Check:
- needle valve ①
Wear/Dirty → Clean
 - float ②
Damage → Change
 - gasket Damage → Change



NOTE: _____

The arm of the float should be supported on the valve without compressing it.

- If the height of the float is not within the specified limits, inspect the valve and its seat.
- Substitute both parts if any part of them is worn.
- If both are in good condition, replace the float.
- Check the height of the float again.

NOTE: _____

The height of the float is adjusted in the factory. Do not try to modify it under any circumstances.

EAS00487

ASSEMBLING THE CARBURETOR

The assembly of the carburetor is carried out following the reverse procedure to “DISASSEMBLY”. Bear in mind the following points:

CAUTION: _____

- Before assembling the carburetor, wash all of the parts in a petroleum-based solvent.
- Always use new gaskets.

1. Install:

- jet needle ①
- clip ②
- throttle valve ③
- spring seat
- spring



Jet needle clip position:
 3/5 (Dell'orto)
 2/3 (Gurtner)
 1/3 (Mofa Version)

2. Install:

- throttle valve ①

NOTE: _____

Align the groove ② with the carburetor projection ③.

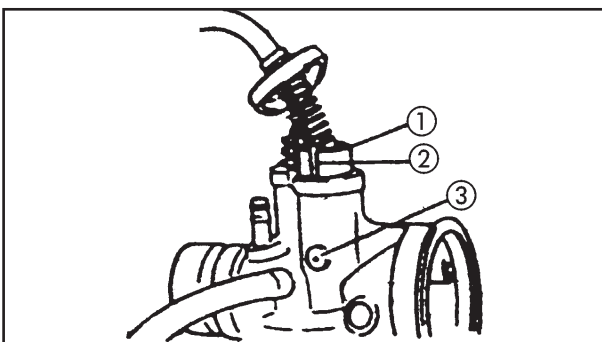
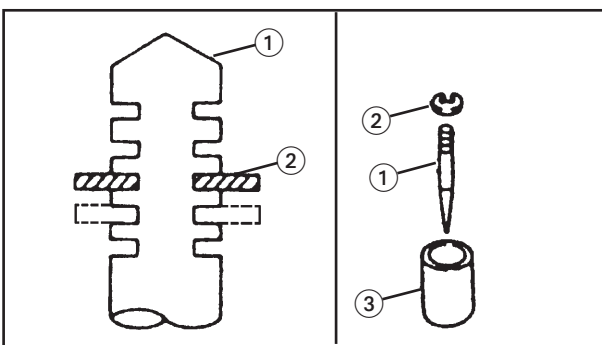

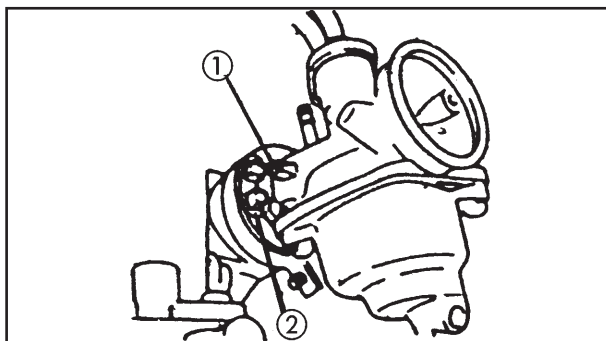

EAS00492

INSTALLING THE CARBURETOR

- Adjust:
 - engine idling speed



Engine idling speed
1.800 rpm

Refer to “ADJUSTING THE ENGINE IDLING SPEED” in chapter 3.

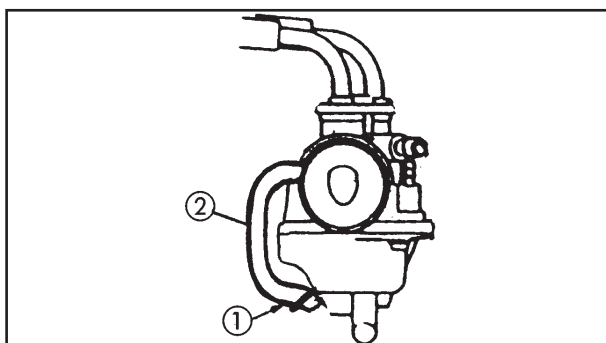

- Adjust:
 - throttle cable free play



Throttle cable free play (at the flange of the throttle grip)
2 ~ 5 mm

Refer to “ADJUSTING THE ENGINE IDLING SPEED” in chapter 3.

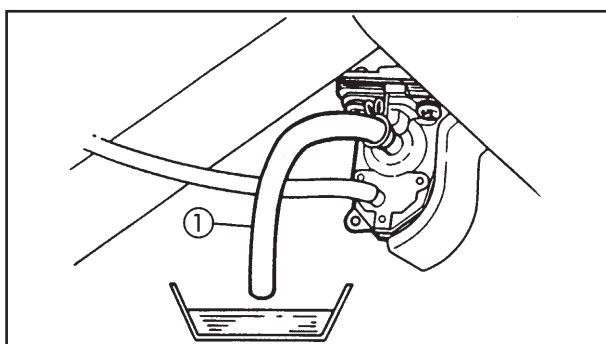

EAS00505

FUEL COCK

CHECKING THE FUEL COCK

- Stop the engine.
- Remove:
 - helmet box
Refer to chapter 3, “REAR BODYWORK, MUDGUARD” section.
- Inspect:
 - fuel cock

Steps for inspecting fuel cock:

- Disconnect the fuel hose ①
- Place a receptacle under the end of the fuel hose.
- Disconnect the vacuum hose ② and suction to create a vacuum
- If the fuel comes out of the fuel hose as a result of applying a vacuum and stops when the vacuum is stopped, the cock is in good condition. If not, clean or replace the vacuum hose, the fuel hose and cock.

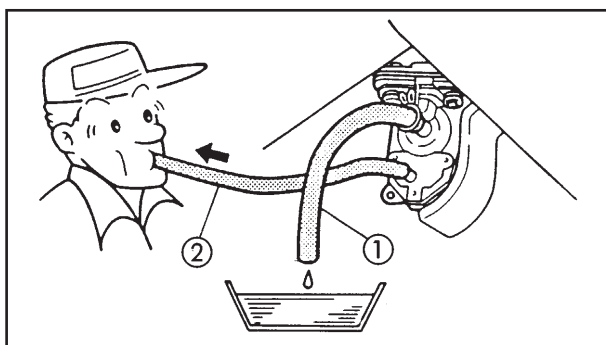

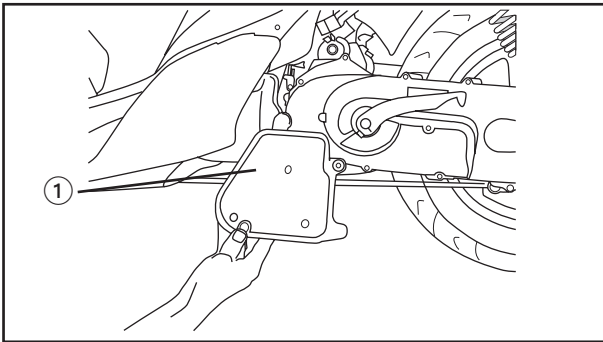

REED VALVE

REMOVING THE REED VALVE

1. Remove:
 - helmet box
Refer to "REAR BODYWORK, MUD-GUARD" in chapter 3.
 - air filter box assembly ①

2. Remove:
 - carburetor
See section "REMOVING THE CARBURETOR"

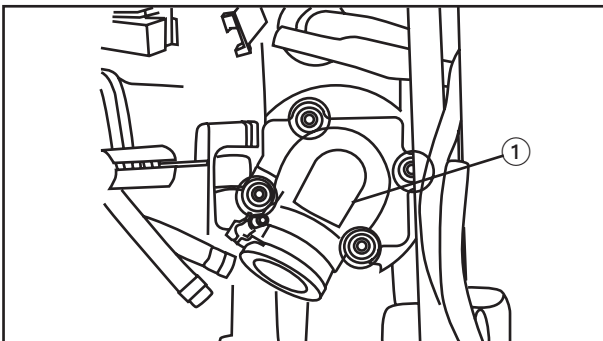

3. Remove:
 - carburetor joint ①
 - reed valve assembly

CHECKING THE REED VALVE

1. Inspect:
 - carburetor joint
Damage/Cracks → Change
 - reed valve
Fatigue/Cracks → Change



Inspection steps:

- Visually inspect the reed valve.
- If there is any doubt on how to seal, apply suction on the carburetor side.
- Leaks should be light or moderate.



REED VALVE

CARB

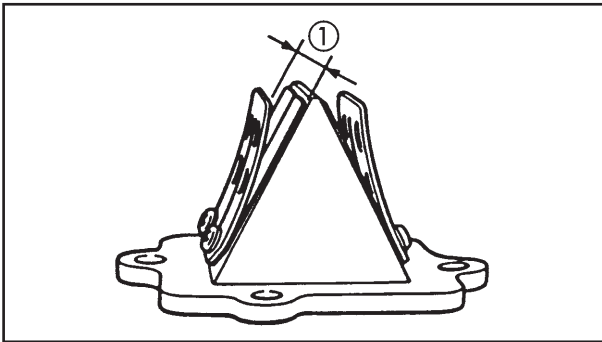

2. Measure:

- valve stopper height ①
Out of specification → Adjust the stopper/Replace the valve stopper.



Height of valve stopper ①
6.0 ~ 6.4 mm

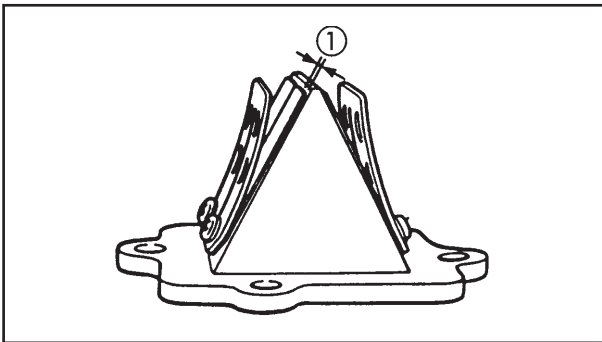

3. Measure:

- clearance of reed valve ①
Out of specification → Replace the reed valve.



Clearance of reed valve ①
Less than 0.2 mm

INSTALLING THE REED VALVE

When the reed valve assembly is installed, reverse the removal procedure. Bear in mind the following points.

1. Install:

- gasket **New**

2. Tighten:

- tighten the bolts for reed valve



Reed valve
11 Nm (1.1 m • kg)

NOTE: _____

Tighten each bolt gradually to avoid it being deformed.

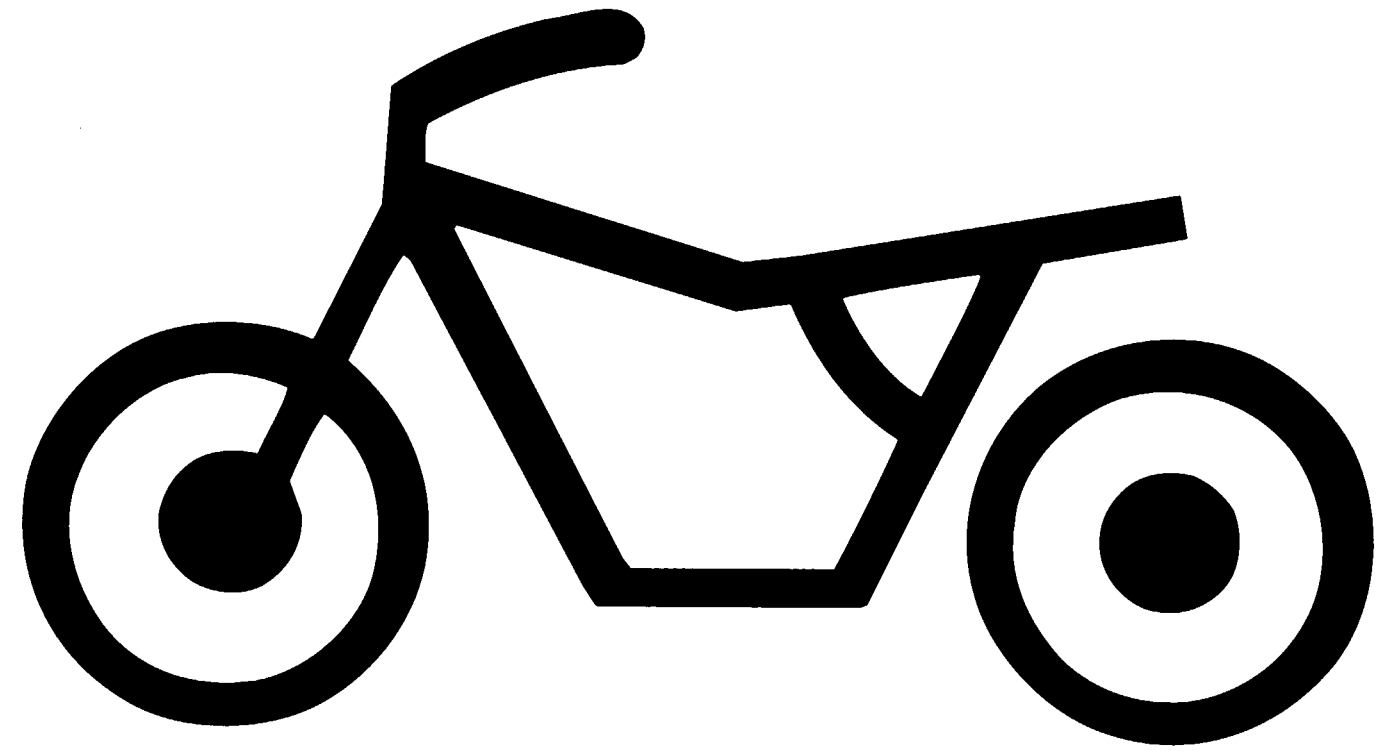

CHAS

6



CHAPTER 6 CHASSIS

FRONT WHEEL	6-1
EXTRACTION	6-2
INSPECTION	6-2
INSTALLATION	6-3
REAR BRAKE	6-4
CHANGE OF BRAKE BLOCKS	6-5
DISASSEMBLY OF CALLIPER	6-6
INSPECTION AND REPAIR	6-7
ASSEMBLY OF CALLIPER	6-7
ASSEMBLY OF PUMP	6-8
REAR WHEEL	6-9
EXTRACTION	6-10
INSPECTION	6-10
ASSEMBLY	6-11
INSTALLATION	6-12
REAR FORK	6-13
EXTRACTION	6-14
DISASSEMBLY	6-14
INSPECTION	6-15
ASSEMBLY	6-16
INSTALLATION	6-18
HANDLEBAR AND STEERING	6-19
REMOVAL	6-20
INSPECTION	6-21
INSTALLATION	6-22



CHASSIS

FRONT WHEEL

- ① Wheel axle
- ② Speedometer gear unit
- ③ Bearing
- ④ Spacer
- ⑤ Hub
- ⑥ Rim assembly
- ⑦ Tyre
- ⑧ Oil seal
- ⑨ Spacer
- ⑩ Nut
- ⑪ Washer

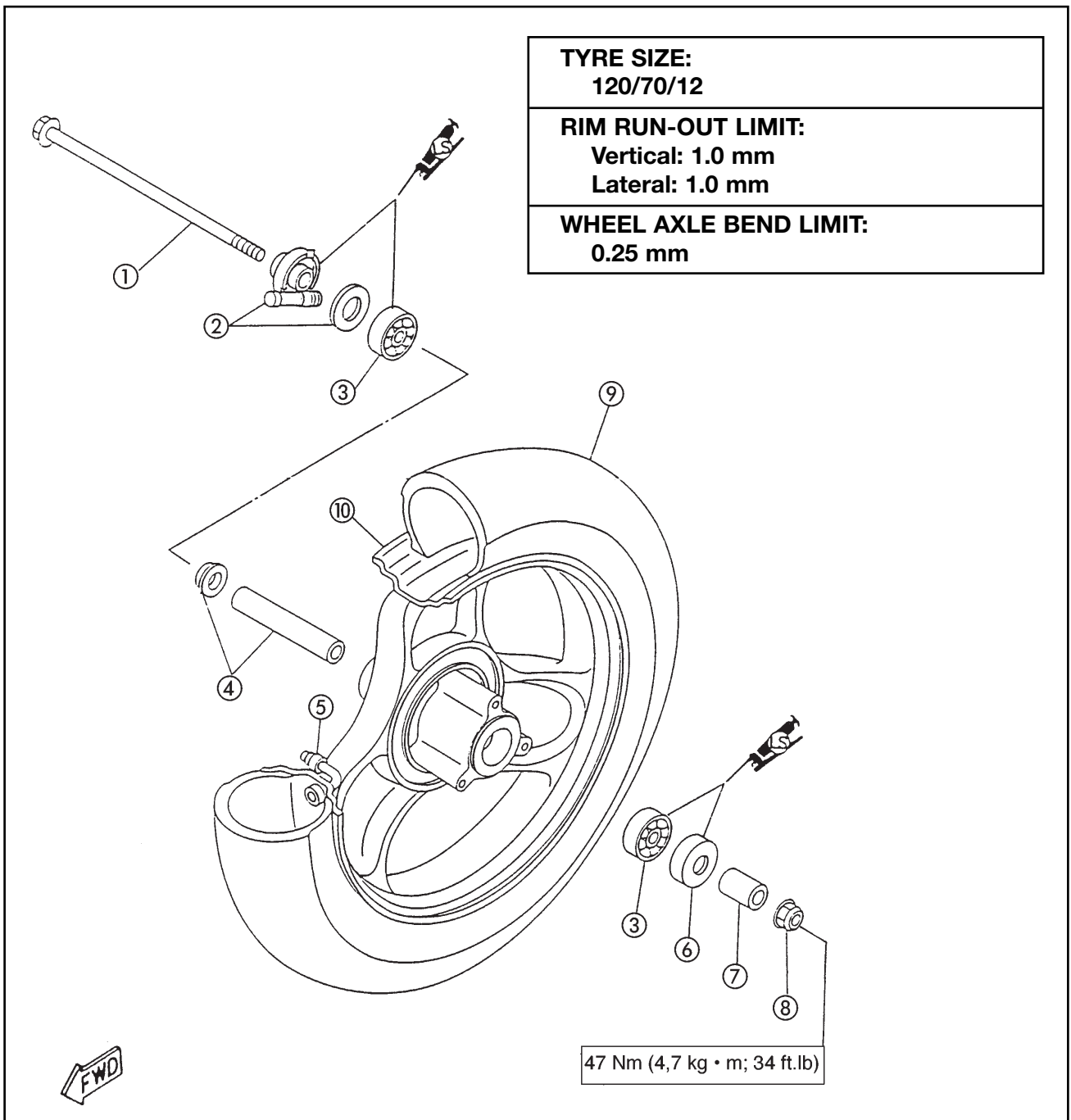

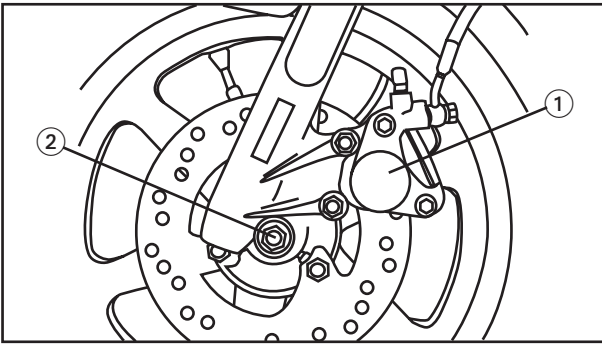

REMOVAL

1. Remove:
 - brake caliper ①
 - Axle ②
 - Wheel

NOTE:

Do not press the brake lever when the wheel is removed from the scooter, otherwise the brake blocks will be closed under force.

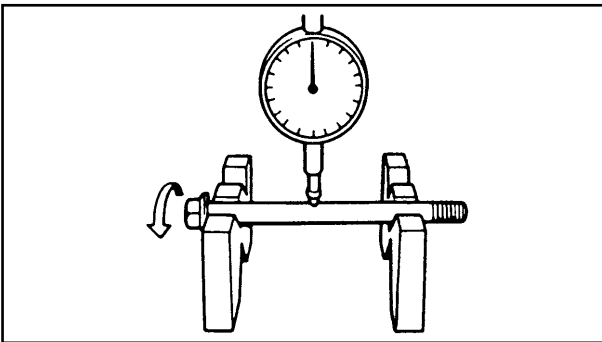

INSPECTION

1. Measure:
 - Bend of wheel axle
Outside specified value → Change

	Bend limit of wheel axle 0.25 mm
--	--

⚠ WARNING

Do not try to straighten a bent axle

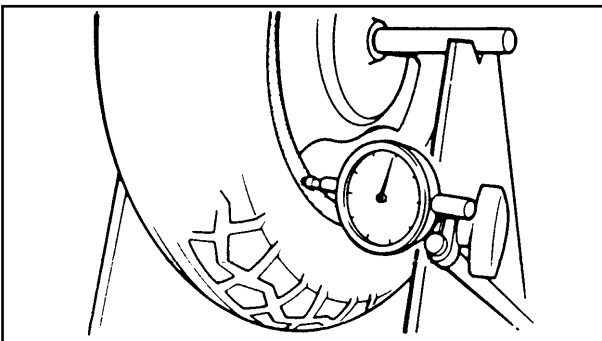

2. Measure:
 - Run out of wheel
Outside specified value → Change

	Run-out limit: Vertical: 1.0 mm Lateral: 1.0 mm
--	--

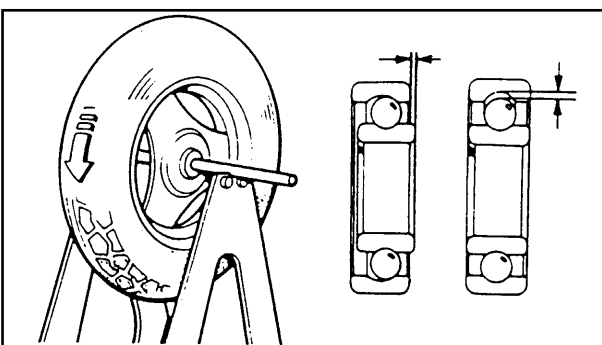

3. Inspect:
 - Wheel Cracks/Marked/Deformed → Change
4. Inspect:
 - Wheel bearings
Bearings allow play on the wheel hub or the wheel turns abruptly → Change

5. Inspect:
 - Speedometer gear unit ①
Wear/Damage → Change



INSTALLATION

Reverse the removal process. Bear in mind the following points.

1. Lubricate:
 - Front wheel axle
 - Bearings
 - Oil seal (edges)
 - Drive gear (speedometer)



Recommended lubricant:
Grease with lithium soap base

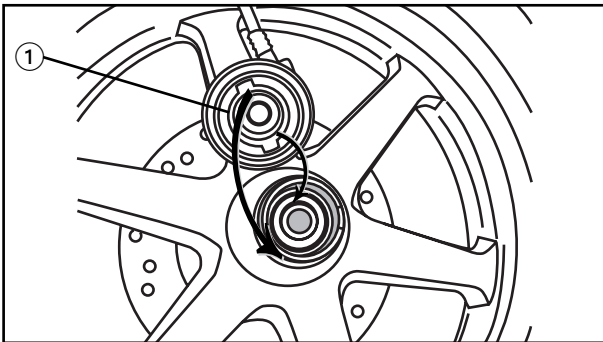

2. Install:
 - Speedometer gear unit ①

NOTE: _____

Ensure that the two projections in the gear unit are engaging with the flat surface of the gear unit.

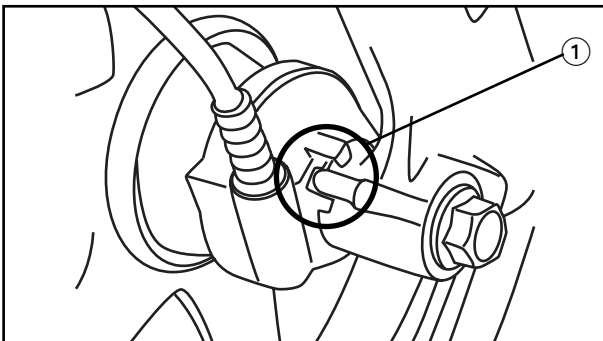

3. Install:
 - Front wheel

NOTE: _____

Ensure that the projection (torsion stopper) ① of the casing of the gear unit is correctly positioned.

4. Tighten:
 - Front wheel axle:



Front wheel axle:
4.8 m • kg

⚠ WARNING: _____

Ensure that the brake pipe is correctly positioned.



FRONT BRAKE

- ① Retaining bolt
- ② Bleed screw
- ③ Calliper assembly
- ④ Block spring
- ⑤ Pad set
- ⑥ Piston seal
- ⑦ Piston
- ⑧ Brake disc
- ⑨ Master cylinder cap
- ⑩ Diaphragm
- ⑪ Hose
- ⑫ Brake pump assembly
- ⑬ Assembly plate
- ⑭ Copper washer
- ⑮ Assembly bolt
- ⑯ Brake light switch cable

TYPE OF BRAKE FLUID
DOT 3 or 4

WEAR LIMIT OF BRAKE PADS:
0.8 mm

WEAR LIMIT OF BRAKE DISC:
3.0 mm

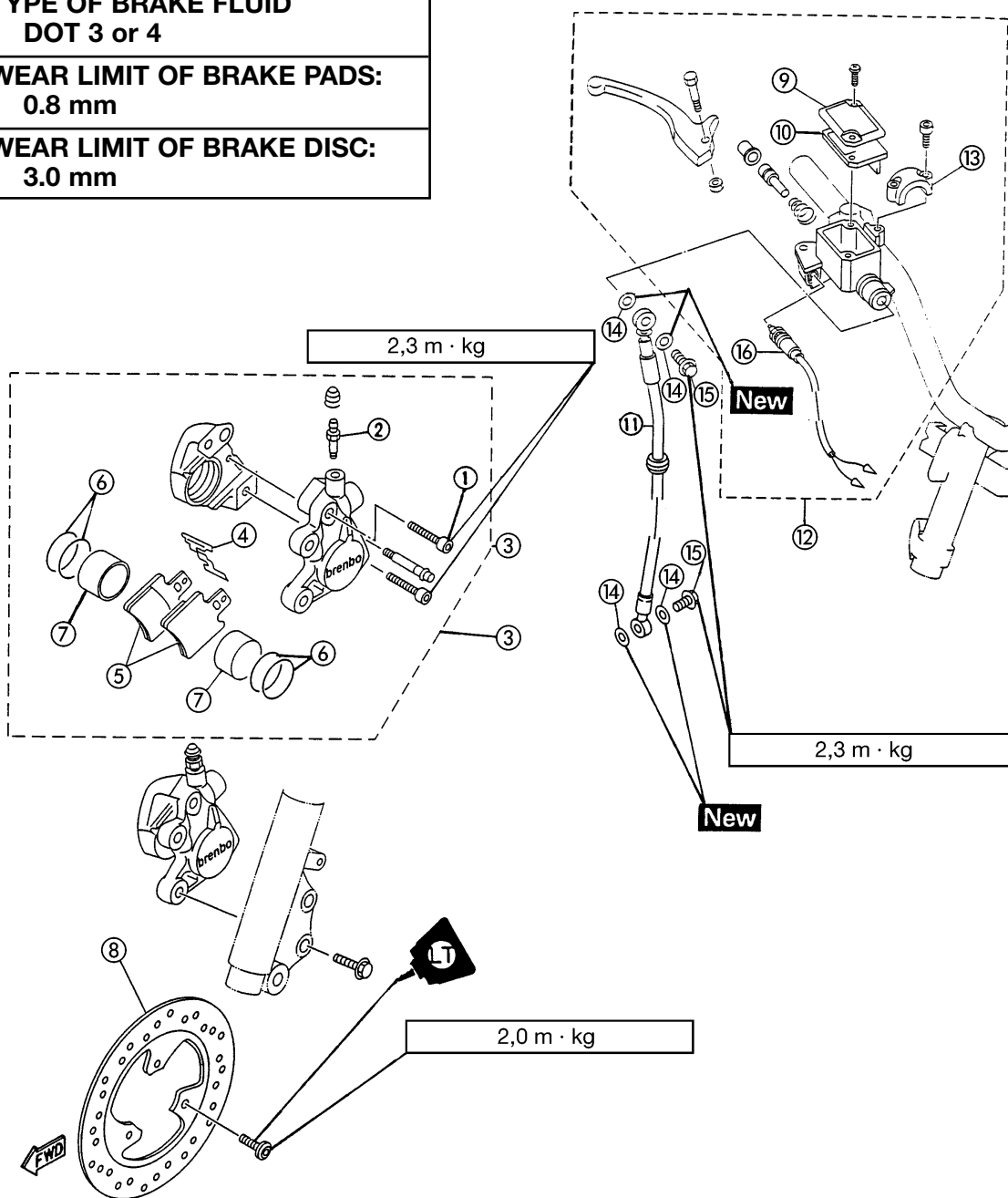

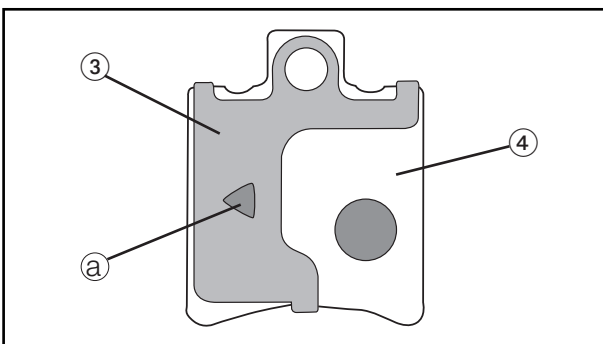
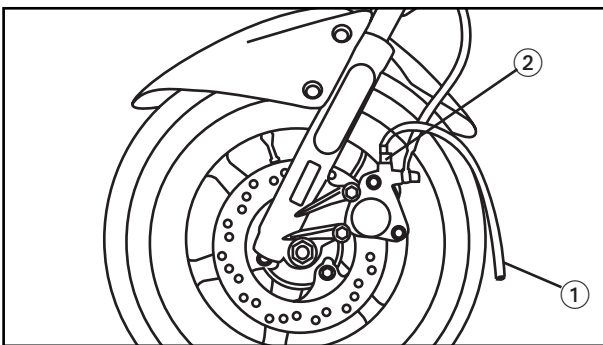
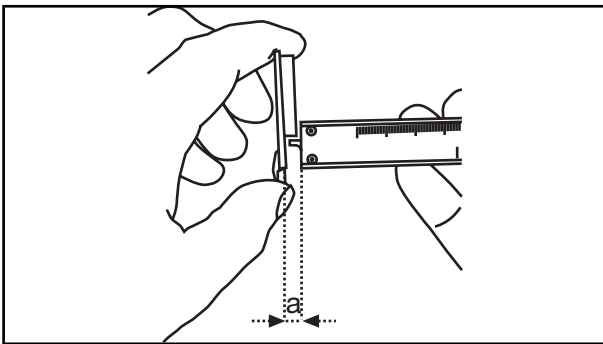
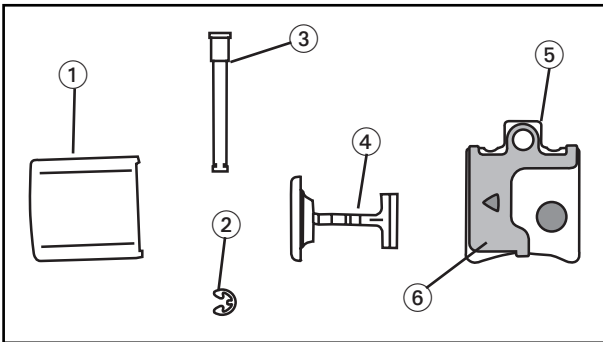
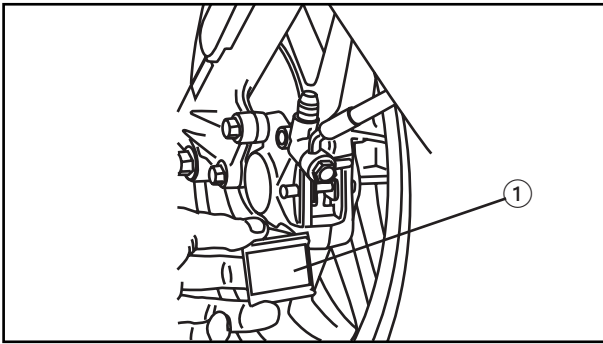

EAS00583

REPLACING THE FRONT BRAKE PADS

NOTE:

When replacing the brake pads, it is not necessary to disconnect the brake hose or disassemble the brake caliper.

1. Remove:

- brake pad cover ①
- brake pad clip ②
- brake pad pin ③
- brake pad spring ④

2. Remove:

- brake pads ⑤
(along with the brake pad shims ⑥)

3. Measure:

- brake pad wear limit @
Out of specification → Replace the brake pads as a set.



Brake pad wear limit
0.5 mm

4. Install:

- brake pad shims
(onto the brake pads)
- brake pads
- brake pad spring

NOTE:

Always install new brake pads, brake pad shims, and a brake pad spring as a set.



- Connect a clear plastic hose ① tightly to the bleed screw ②. Put the other end of the hose into an open container.
- Loosen the bleed screw and push the brake caliper pistons into the brake caliper with your finger.
- Tighten the bleed screw.



Bleed screw
6 Nm (0.6 m• kg)

- Install a new brake pad shim ③ onto each new brake pad ④.

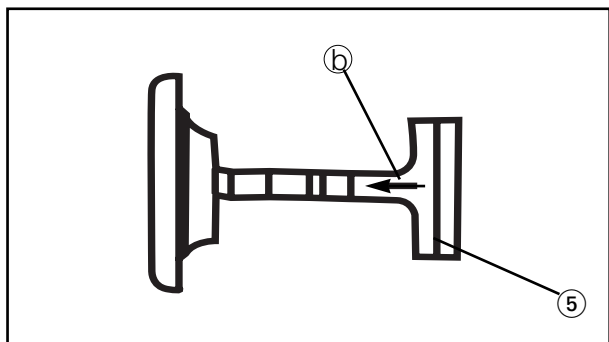

NOTE: _____

The triangle mark (a) on the brake pad shim must point in the direction of disc rotation.

e. Install new brake pads and a new brake pad spring (5).

NOTE: _____

The arrow mark (b) of the brake pad spring must point in the direction of disc rotation.



5. Install:
- brake pad pins
 - brake pad clips
 - brake pad cover

6. Check:
- brake fluid level
- Below the minimum level mark → Add the recommended brake fluid to the proper level. Refer to “CHECKING THE BRAKE FLUID LEVEL” in chapter 3.

7. Check:
- brake lever operation
- Soft or spongy feeling → Bleed the brake system. Refer to “BLEEDING THE HYDRAULIC BRAKE SYSTEM” in chapter 3.

REMOVING THE BRAKE HOSE

NOTE: _____

Before replacing the brake hose, drain the brake fluid from the entire brake system.

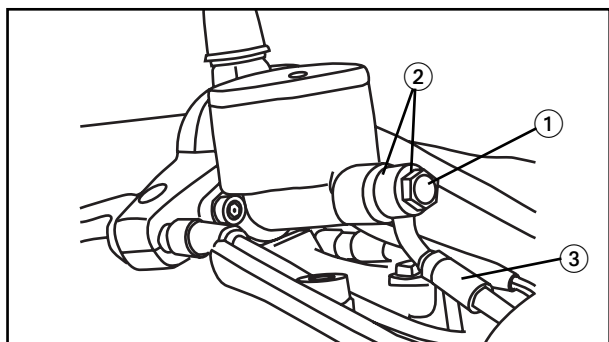

1. Remove:
- union bolt (1)
 - copper washers (2)
 - brake hose (3)

NOTE: _____

To collect any remaining brake fluid, place a container under the end of the brake hose.

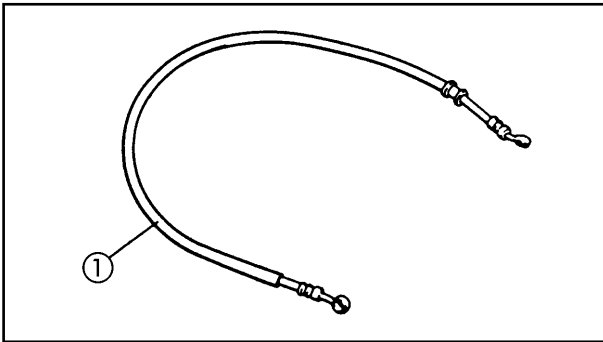

CHECKING THE BRAKE HOSE

1. Check:
 - brake hoses ①
cracks/damage/wear → Replace.

BRAKE HOSE ASSEMBLY

⚠ WARNING

- All internal parts should be cleaned only in new brake fluid.
- Internal parts should be lubricated with brake fluid when installed.



Recommended brake fluid
DOT 4

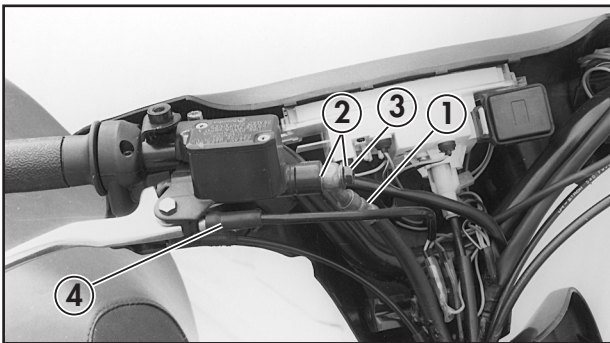

1. Install:
 - Brake hose ①
 - Copper washers ②
 - Assembly bolts ③
 - Brake switch ④



Assembly bolt:
2.3 m • kg

⚠ WARNING

- The correct positioning of the hose is essential to ensure the safe operation of the scooter. See “CABLE ROUTING”.
- Always use new copper washers.

2. Ensure that the brake hose does not touch other parts (accelerator cable, installation, cables, etc.) by turning the handlebar to the left and right. If it does touch, correct this.

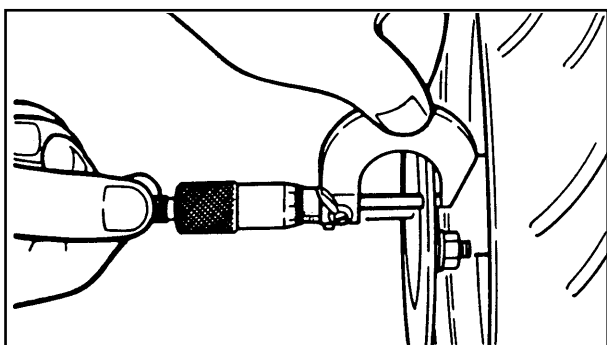
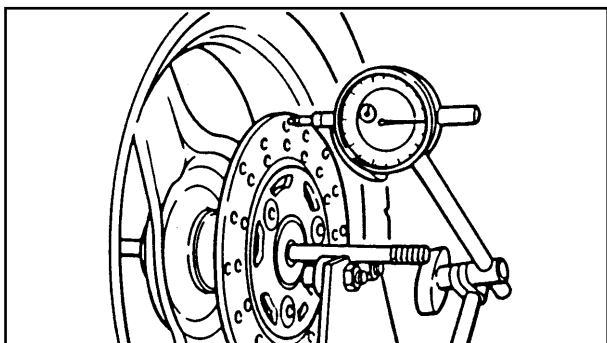

CHECKING THE BRAKE DISC

1. Measure:

- Deflection of brake disc
Outside specified value → Inspect run-out of wheel.
If the wheel is in good condition, change the brake disc



Maximum deflection
0.5 mm

- Brake disc thickness
Outside specified value → Change



Minimum thickness
3.0 mm



Bolt (brake disc)
2.0 m • kg
LOCTITE®



REAR WHEEL

- ① Flat washer
- ② Valve
- ③ Nut
- ④ Flat washer
- ⑤ Return spring
- ⑥ Brake shoe
- ⑦ Brake cam
- ⑧ Shoe axle
- ⑨ Wear indicator
- ⑩ Brake lever

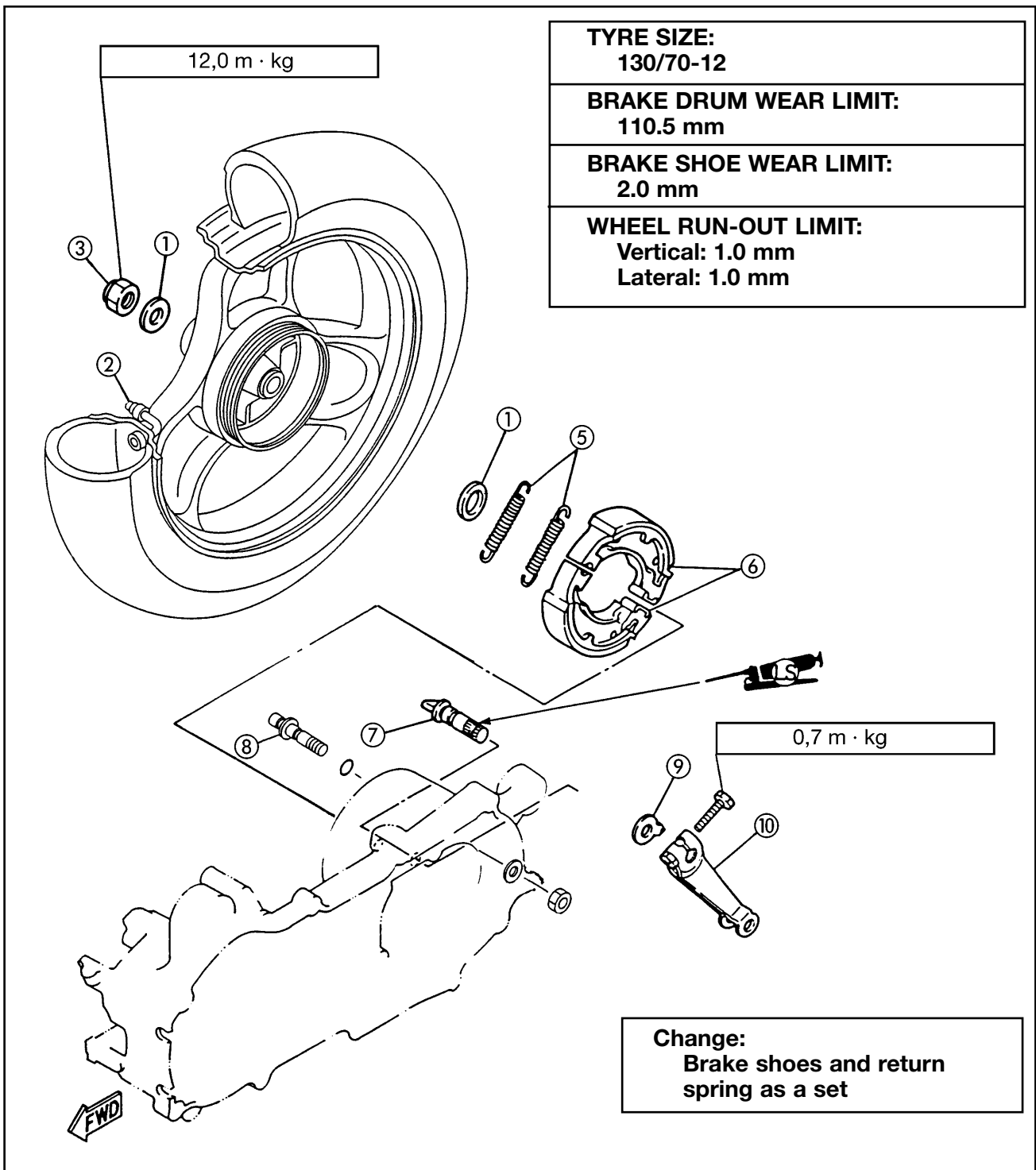

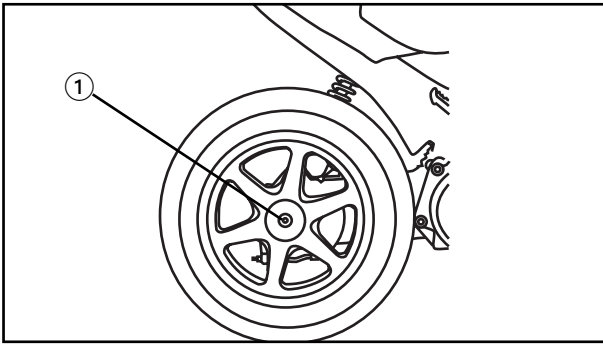

REMOVAL

1. Remove:
 - Exhaust pipe assembly
2. Loosen:
 - Rear axle nut ①

NOTE:

When the axle nut is loosened, apply rear brake.

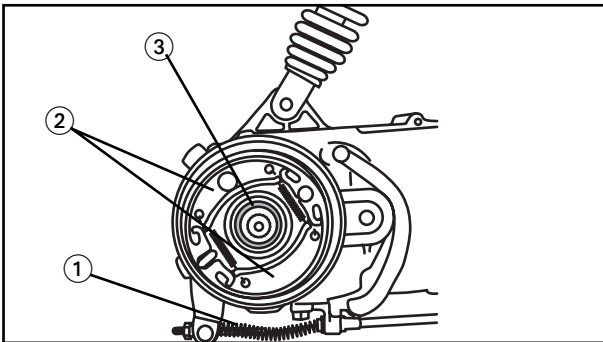

3. Remove:
 - Rear wheel
4. Remove:
 - Rear brake cable ①
 - Brake shoes ②
 - Flat washer ③

INSPECTION

1. Inspect:
 - Wheel
See "INSPECTION OF REAR WHEEL" section
2. Measure:
 - Wheel run-out
See "INSPECTION OF REAR WHEEL" section



Rim run-out limits:
Vertical: 1.0 mm
Lateral: 1.0 mm

3. Check:
 - Wheel bearings Consult the "INSPECTION OF REAR WHEEL" section

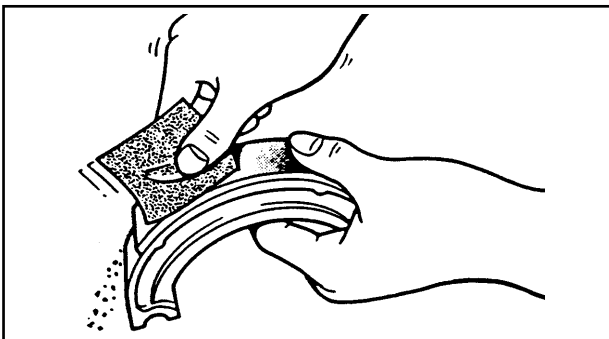

4. Inspect:
 - Brake shoes Crystallisation → Polish with sand paper.

NOTE:

After using sand paper, clean the polished particles with a cloth.

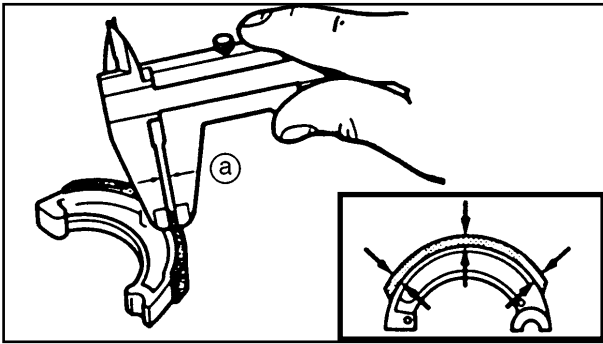

5. Measure:
- Thickness of brake shoes (a)
 - Outside specified value → Change



Brake shoes thickness
4.0 mm
Limit: 2.0 mm

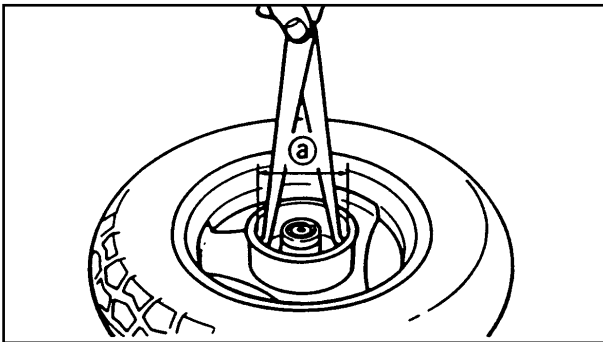

6. Inspect:
- Drum brake inner surface
 - Oil/Scratches → Change
7. Measure
- Drum brake inner diameter (a)
 - Out of specification → Change



Wear limit of brake drum
110.5 mm

ASSEMBLY

When the brake shoe carrier plate is assembled, reverse the removal procedure. Bear in mind the following points.

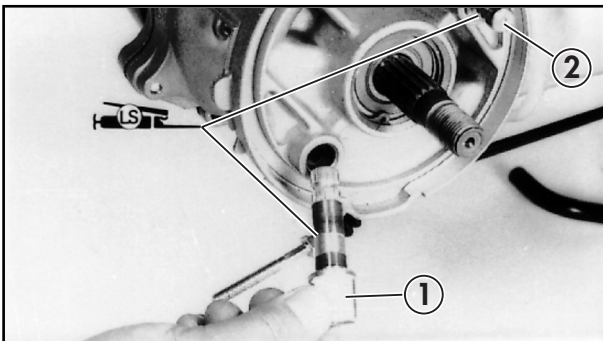

1. Install:
- Brake cam (1)

NOTE:

Apply Grease with a lithium soap base on the brake cam (1) and pin (2).

ATTENTION:

After installing the brake cam, remove excess grease.

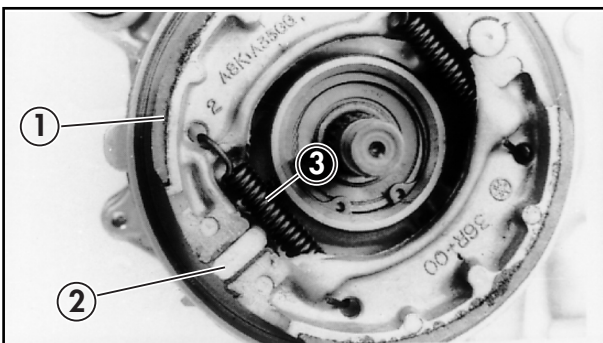

2. Install:
- Brake shoes (1)
 - Return spring (2)

NOTE:

Install with the mark (3) outwards.

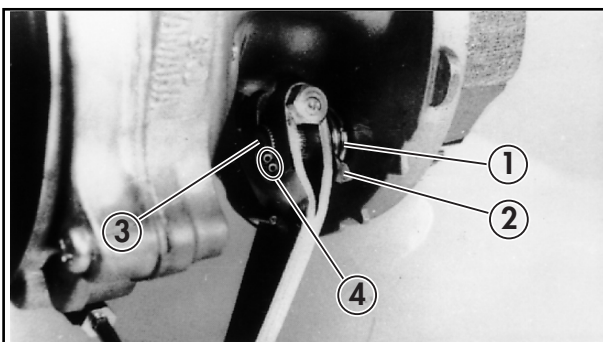

3. Install:
- Torsion spring (1)
 - Wear indicator (2)
 - Cam lever (3)

NOTE:

- Align the projection of the wear indicator (2) with the line as shown.
- Align the punch marks (4).

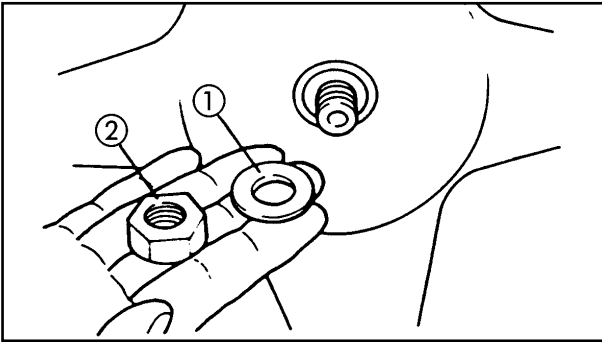
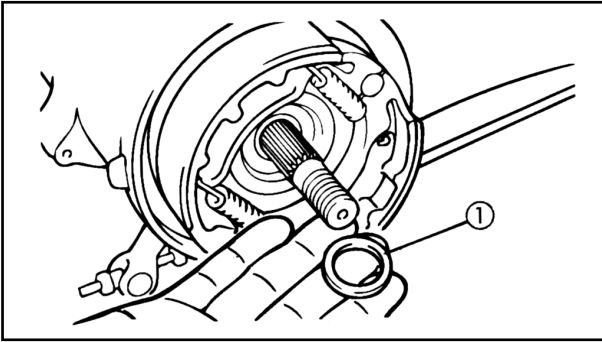

	Bolt (cam lever): 0.7 m • kg
--	---

4. Install:
- Flat washer ①
 - Brake cable

INSTALLATION

When installing the rear wheel, reverse the removal procedure. The following points should be remembered.

1. Install:
- Rear wheel
 - Flat washer ①
 - Nut ②

	Nut (Rear wheel axle): 12.5 m • kg
--	---

2. Install:
- Silencer

	Bolt (exhaust pipe side): 0.9 m • kg Bolt (silencer side): 2.6 m • kg
--	--

3. Adjust:
- Free play of rear brake lever
 See section in chapter 3 "CHECKING FREE PLAY OF REAR BRAKE LEVER".



FRONT FORK

- ① Front fork assembly (left)
- ② Rubber cap
- ③ Restraining ring
- ④ Restraining ring
- ⑤ Cap
- ⑥ O-ring
- ⑦ Dust guard
- ⑧ Retainer
- ⑨ Oil seal
- ⑩ Fork spring
- ⑪ Sliding metal
- ⑫ Shock absorber rod
- ⑬ Return spring
- ⑭ Bar
- ⑮ Oil lock piece
- ⑯ Outer tube
- ⑰ Front fork assembly (right)

FREE LENGTH OF FORK SPRING:

LIMIT:

LEFT 226 mm

RIGHT 226 mm

FORK OIL CAPACITY:

50 cc ± 1 cc

GRADE:

10 W oil fork or equivalent

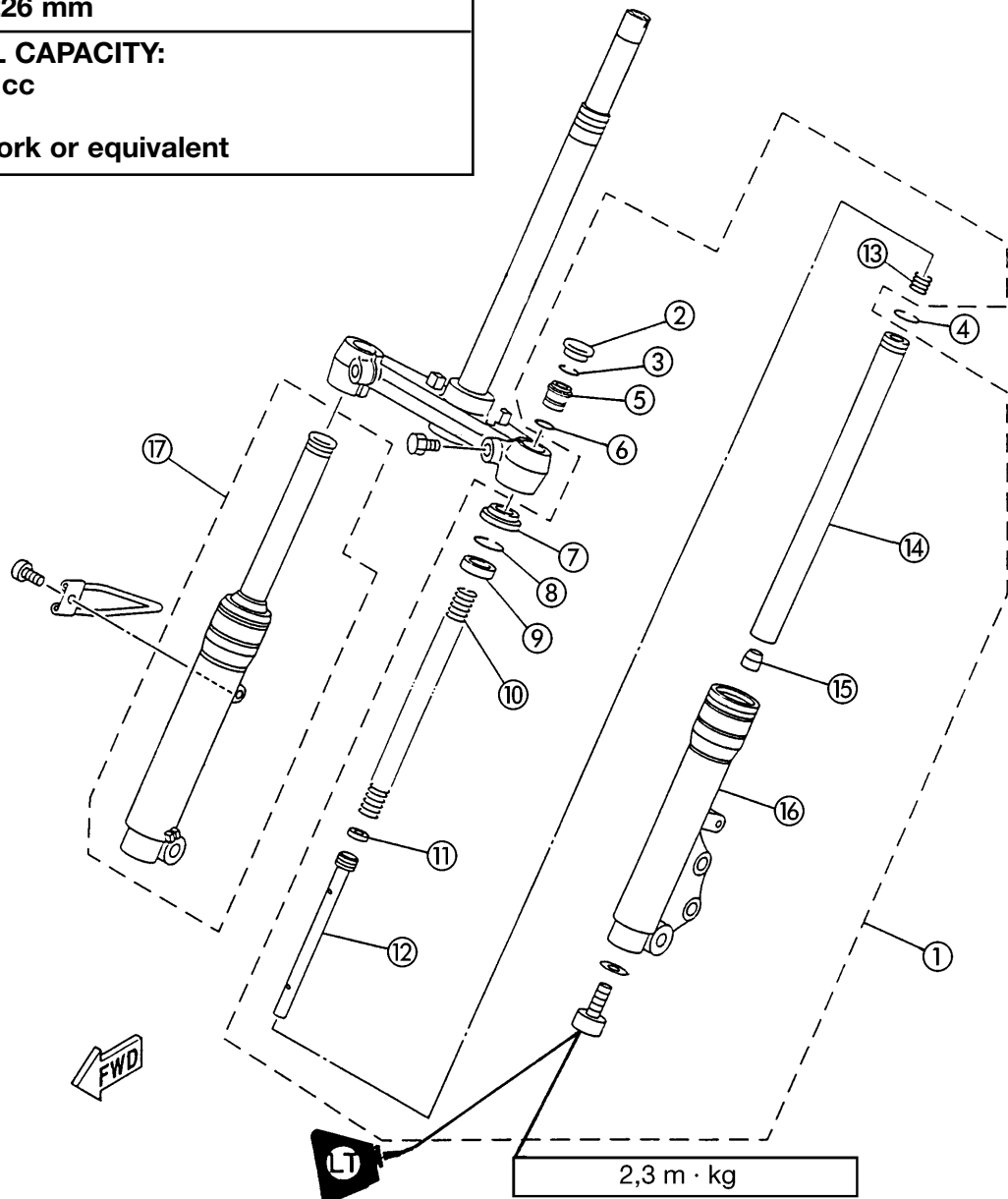



REMOVAL

1. Place the scooter on its central stand and place an adequate support under the engine
2. Remove:
 - Brake callipers
 Consult "FRONT BRAKE REMOVAL" section
3. Remove:
 - Front wheel
 See "FRONT WHEEL REMOVAL SECTION"
4. Remove:
 - Mudguard, front fairing
 See chapter 3 "FRONT BODYWORK, MUDGUARD"

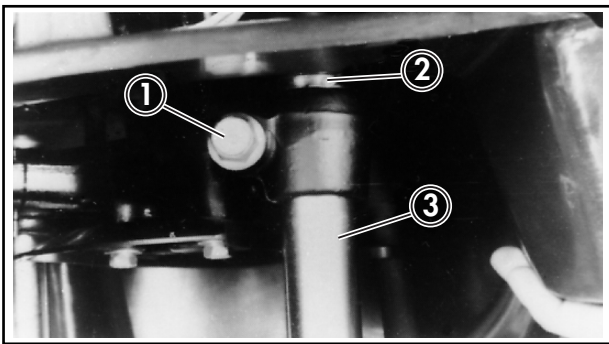

5. Loosen:
 - Positioning bolt ① (fork)
6. Remove:
 - Restraining ring ②
 - FRONT FORK ③

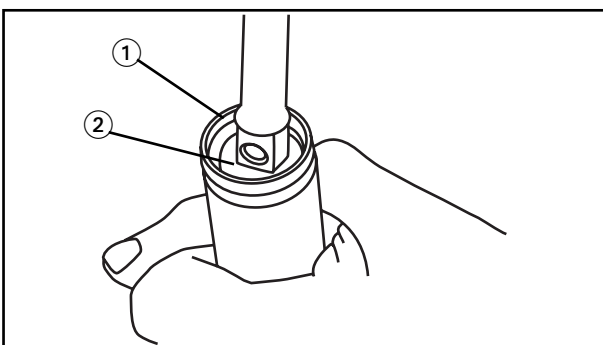

DISASSEMBLY

1. Remove:
 - Rubber cap
 - Restraining ring ①
 - Cap ②
 - Fork spring
2. Drain:
 - Fork oil
3. Remove:
 - Mudguard
 - Retainer ①

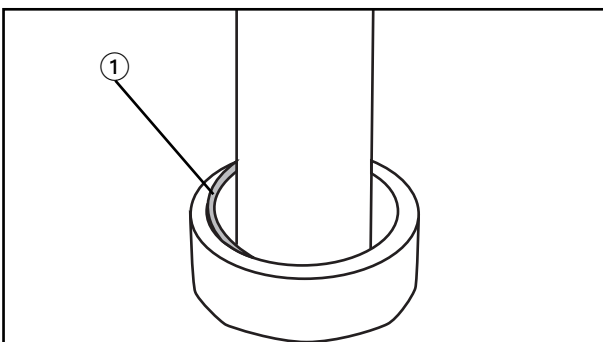

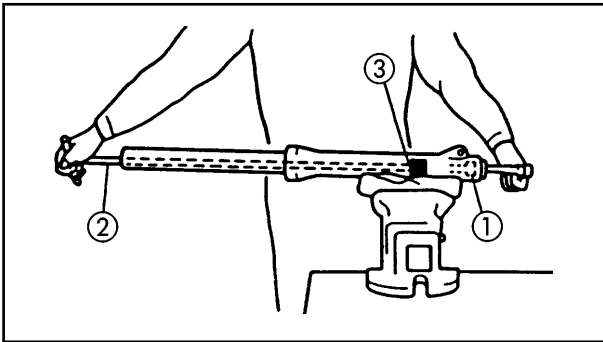

4. Remove:
- Bolt (shock absorber rod) ①
 - Copper washer

NOTE:

Remove the bolt (shock absorber rod) while the shock absorber rod is held with the T-handle ② and a support ③



T-handle:
90890-01326
Support:
90890-01294-A

5. Remove:
- Inner pipe
 - Shock absorber rod
 - Oil lock piece (left side)
 - Oil seal

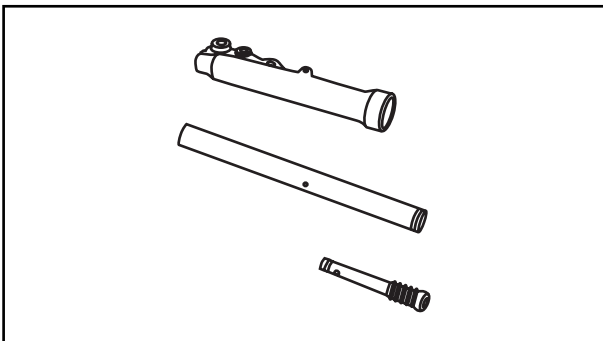

INSPECTION

1. Inspect:
- Fork bar
 - Outer tube
 - Shock absorber rod
- Striping/Warping/Wear/Damage → Change

⚠ WARNING

Do not try to straighten a fork bar or an outer tube as this may dangerously weaken the tube.

2. Measure:
- Fork spring
- Above specified limit → Change



Free length of fork spring (limit) ①:
Left 226 mm
Right 226 mm

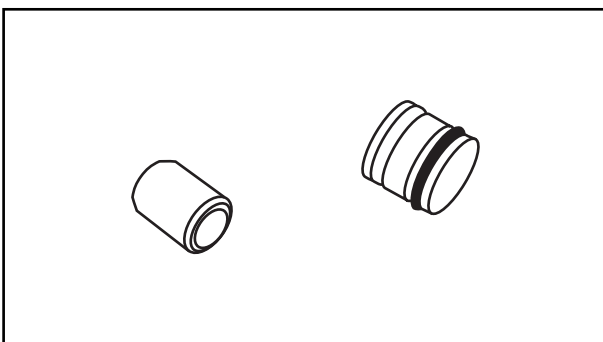
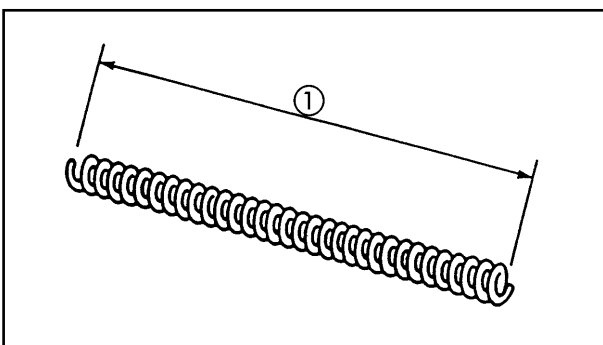

3. Inspect:
- Oil lock piece
 - O-ring (cover)
- Wear/Damage → Change



ASSEMBLY

Reverse the disassembly procedure. Bear in mind the following points.

NOTE:

- When assembling the fork, ensure that the following new parts are used.
- Oil seal
- Mudguard
- Sliding metal
- Ensure that all components are clean before assembly.

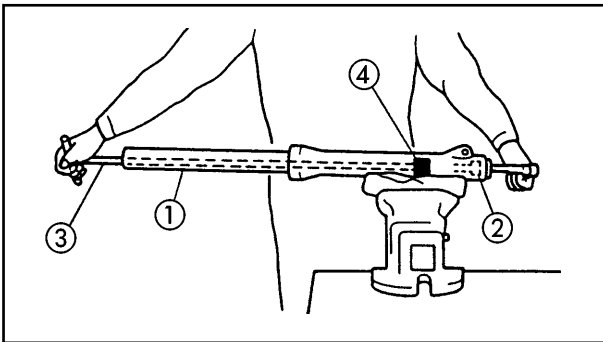

1. Install:

- Shock absorber rod
- Oil lock piece (left side)
- Bar ①
- Copper washer (new)
- Bolt (shock absorber rod) ②



Bolt (hydraulic rod):
23 Nm (2.3 m • kg, 17 • lb)
LOCTITE®

NOTE:

Tighten the bolt (hydraulic rod) while supporting the bar with the T-handle ③ and the support ④.



T-handle:
90890-01326
Support:
90890-01294-A

2. Install:

- Oil seal ①
- Use a counterbalance for installing fork seals ③ and an adaptor ②.

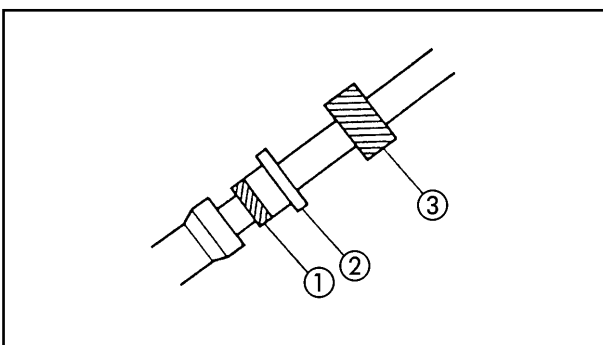

Counterbalance for installing oil seals:
90890-01184
Adaptor:
90890-01186

NOTE:

Before installing the oil seal, apply grease with a lithium soap base on the edges of same.

ATTENTION:

Ensure that the numbered side of the seal is facing upwards.

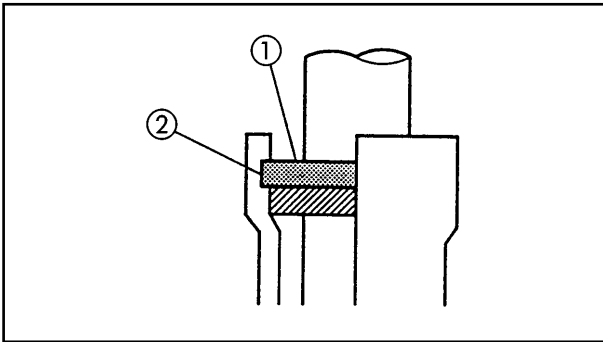

3. Install:
- Retainer ①
 - Dust guard

NOTE: _____

Couple the retainer correctly on the groove of the outer tube ②.

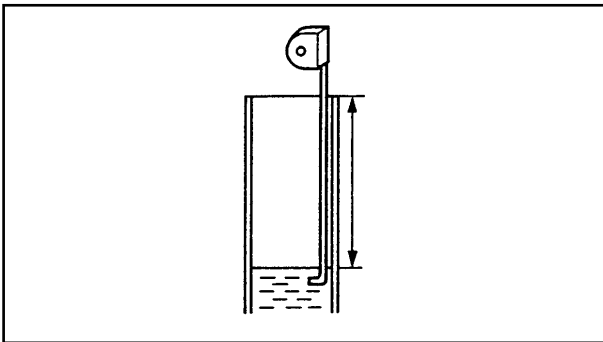

4. Fill :
- Fork oil



Each fork:
50 cm³
10 W fork oil or equivalent after filling, slowly pump the fork to distribute the oil.



Oil level:
95 mm
From the upper part of the inner fork tube totally compressed without the spring.

NOTE: _____

Place the fork in a vertical position.

5. Install:
- Fork spring
 - Cover
 - Restraining ring
 - Rubber cap

NOTE: _____

- Before installing the cover, apply grease to the o-ring.
 - Couple the restraining ring correctly on the inner tube groove.
-



INSTALLATION

Reverse the removal procedure.

The following points should be remembered

1. Install:
 - Front fork:
 - Stopper ring

NOTE:

Attach the stopper ring correctly on the inner tube groove.



2. Tighten:
 - Positioning bolt (lower bracket)



Positioning bolt (inner lever arm)
30 Nm (3.0 m • kg, 22 ft • lb)

3. Install:
 - Front wheel
 - Brake calliper
 - Clasp (brake hose)
 - Speedometer cable
See "FRONT WHEEL" section
 - Front mudguard
See chapter 3, section "FRONT BODY-WORK MUDGUARD"



Wheel axle
48 Nm (4.8 m • kg, 35 ft • lb)

HANDLEBAR AND STEERING

- | | |
|---|---|
| <ul style="list-style-type: none"> ① Handlebar ② Grip cap ③ Throttle grip ④ Throttle grip guide ⑤ Grip ⑥ Nut ⑦ Bolt ⑧ Throttle cable ⑨ Brake cable ⑩ Upper ring nut | <ul style="list-style-type: none"> ⑪ Lock washer ⑫ Center ring nut ⑬ Rubber washer ⑭ Lower ring nut ⑮ Bearing cover ⑯ Upper bearing race ⑰ Bearing cage ⑱ Bearing race ⑲ Lower bracket |
|---|---|

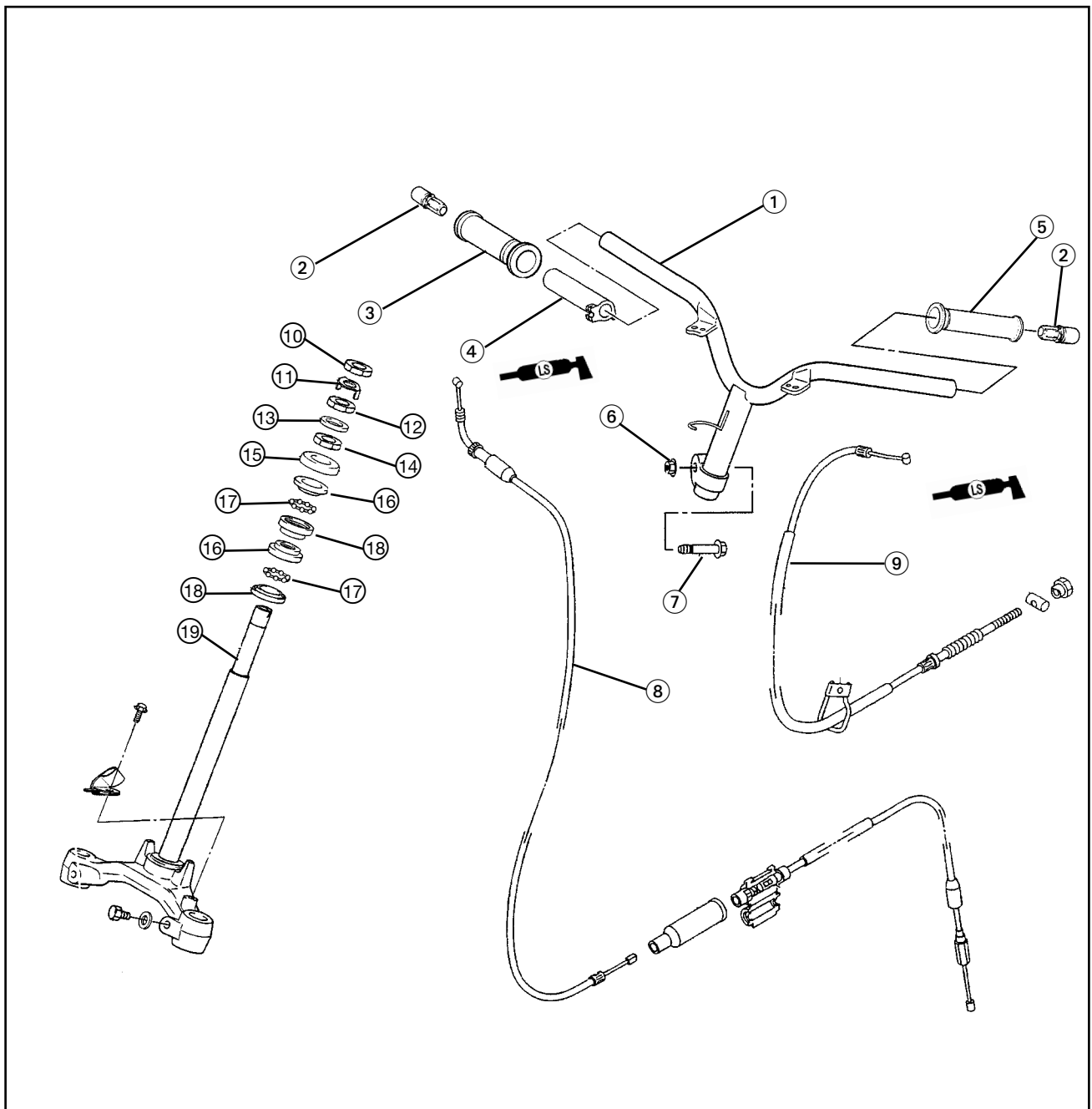



REMOVAL

1. Place the scooter on its central stand and place a suitable support under the engine.
2. Remove:
 - Front wheel
See section "REMOVAL OF FRONT WHEEL"
3. Remove:
 - Mudguard
 - Front fairing
See chapter 3, "FRONT BODYWORK, MUDGUARDS" section.
4. Remove:
 - Handlebar covers See chapter 3 "HANDLEBAR COVER" section

NOTE:

Before completely removing the rear cover with the speedometer, disconnect the speedometer cable and the signalling and lighting system cables.

5. Remove:
 - Front fork
See "REMOVAL OF FRONT FORK" section

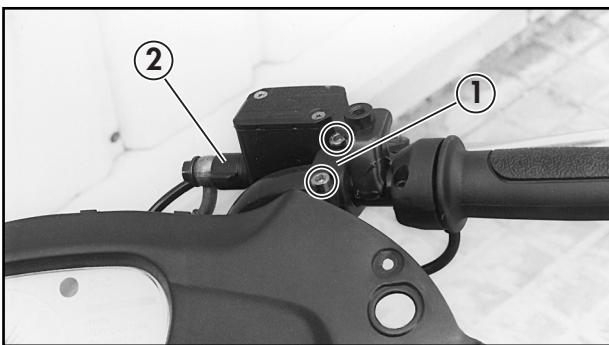

6. Remove:
 - Brake pump support
 - Brake pump.
 - Throttle grip

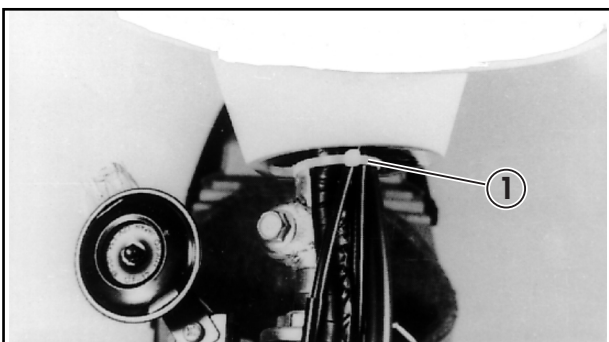

7. Remove:
 - Flange ① (electrical installation)

8. Remove:
- Upper ring nut

	Ring nut wrench for steering 90890-01403
---	--

⚠ WARNING

Support the steering axle so that it does not fall.

9. Remove:
- Lock washer
 - Central ring nut
 - Rubber washer
 - Lower ring nut
 - Bearing cover
 - Lower bracket

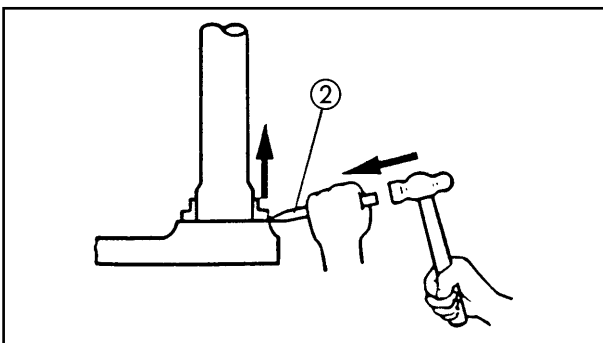
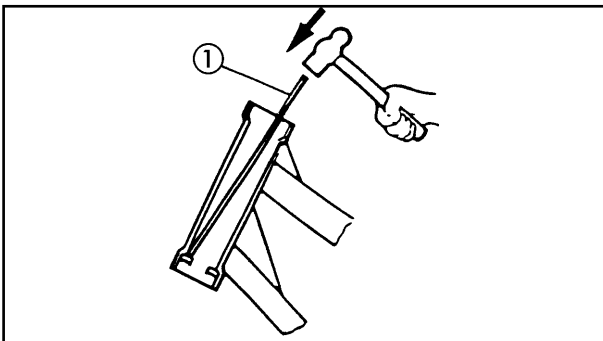

INSPECTION

1. Wash the bearing and race with solvent.
2. Inspect:
 - Bearings
 - Bearing race
 - Pitted/Damage → Change



Steps for replacing the bearing race:

- Remove steering bearing races using a long rod ① and the hammer as shown.
- Remove the bearing race from the shaft using a chisel ② and the hammer as shown.
- Install the new mudguard and the guides.





NOTE:

- Always change the bearing and the races together.
- Change the mudguard whenever the steering head is disassembled.

ATTENTION:

If the bearing race is not coupled correctly, the steering tube may be damaged.

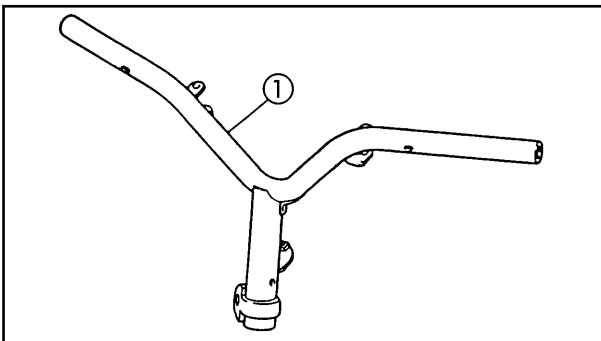
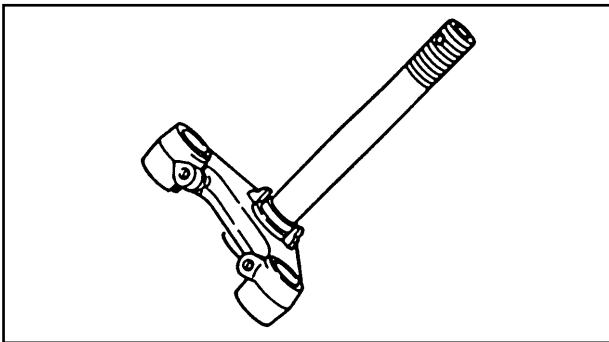

3. Inspect:

- Lower lever arm (with steering rod)
Cracks/Damage → Change

4. Inspect:

- Handlebar ①
Cracks/Damage → Change

⚠ WARNING

Do not try to straighten a bent handlebar since this can weaken it dangerously.

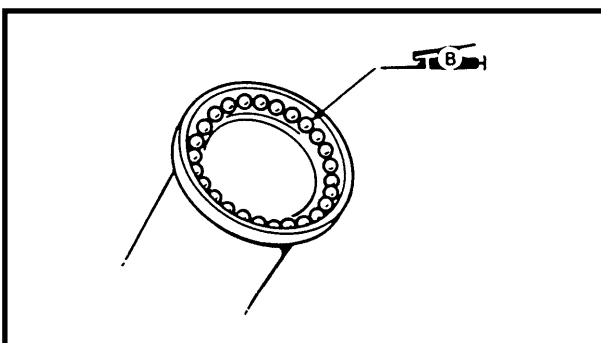

INSTALLATION

Reverse the steps for disassembly and removal. The following points should be remembered

1. Apply:

- Wheel bearing grease
(on upper bearings and lower bearings.)

2. Install:

- Lower bracket ①
- Lower ring nut ②
- Rubber washer ③
- Central ring nut ④
- Lock washer ⑤
- Upper ring nut ⑥

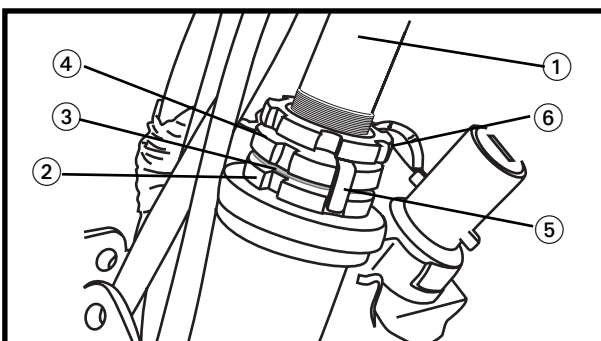

ATTENTION:

Support the steering column until it is in position.

3. Tighten:
 - Steering nut



Steps for tightening the steering nut:

1. Tighten the lower ring nut ② to 3.8 m•kg.
2. Loosen the lower ring nut ② 1/2 of a turn and tighten to 0.65 m•kg.
3. Check the steering for smooth operation.
4. Install rubber washer ③.
5. Install central ring nut ④ and hand tighten until the lower and central ring nuts slots align.
6. Install the lock washer ⑤.
7. Supporting the lower and central ring nuts, install and tighten the upper ring nut to 7.5 m•kg.

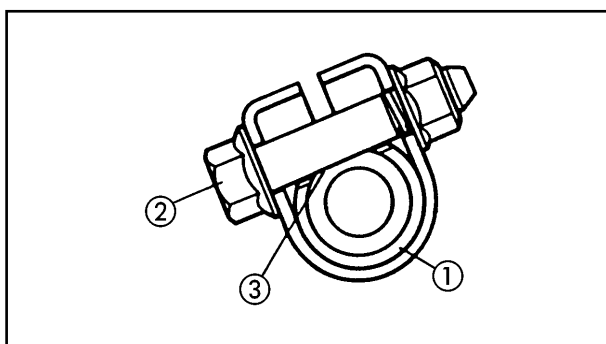

4. Install:
 - Handlebar ①
 - Bolt ②
 - Nut

NOTE: _____

Match up the bolt ② on the tooth of the steering column ③.

	<p>Bolt (handlebar) 4.3 m • kg</p>
---	---

5. Install:
 - Flange

NOTE: _____

Support electrical installation

6. Apply:
 - Grease with lithium soap base (on the end of the accelerator cable and right end of the handlebar.)

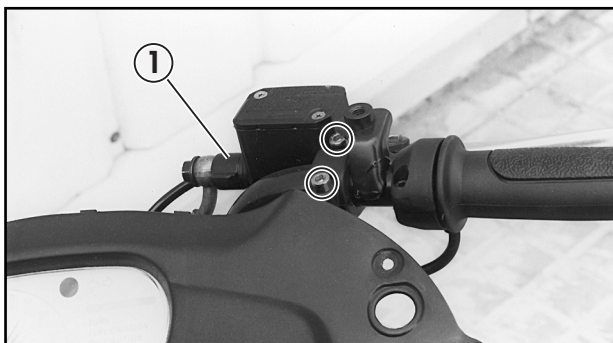

7. Install:
- Brake pump ①

NOTE: _____

First tighten the upper bolt, then the lower bolt.



Bolt (brake pump)
0.9 m • kg

8. Install:
- Rear handlebar cover with speedometer
 - Front handlebar cover

NOTE: _____

Connect the speedometer cables, signalling and lighting systems.

ATTENTION: _____

Situate the speedometer cable through its housing in the rear cover.

9. Install:
- Front fork
See "INSTALLATION OF FRONT FORK SECTION".
10. Install:
- Front wheel
See section "INSTALLATION OF FRONT WHEEL"

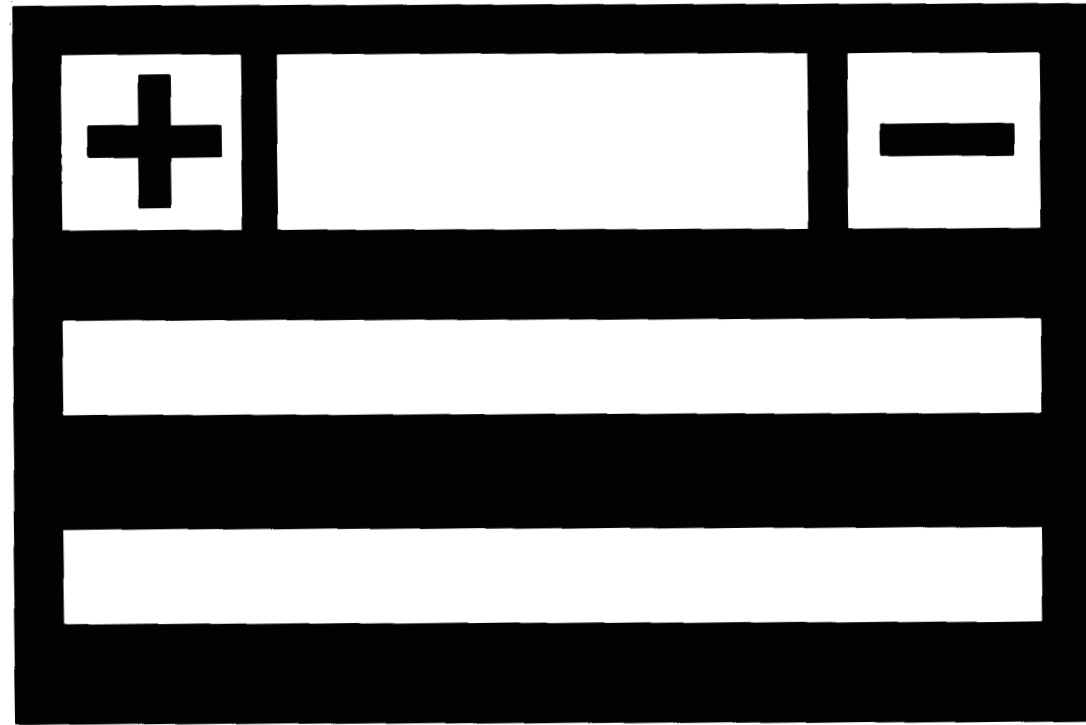

ELEC

7

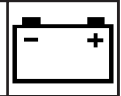

CHAPTER 7 ELECTRICAL SYSTEM

ELECTRICAL COMPONENTS	7-1
IGNITION AND STARTER SYSTEM	7-3
CIRCUIT DIAGRAM	7-3
IGNITION AND STARTER CIRCUIT SYSTEM	7-4
TROUBLESHOOTING	7-5
CHARGING SYSTEM	7-10
CIRCUIT DIAGRAM	7-10
LOCATION AND REPAIR OF FAULTS	7-11
LIGHTING SYSTEM	7-13
CIRCUIT DIAGRAM	7-13
LOCATION AND REPAIR OF FAULTS	7-14
CHECKING OF LIGHTING SYSTEM	7-15
SIGNALLING SYSTEM	7-17
CIRCUIT DIAGRAM	7-17
LOCATION AND REPAIR OF BREAKDOWNS	7-18
CHECKING OF SIGNALLING SYSTEM.....	7-19

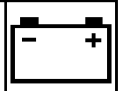

ELECTRICAL SYSTEM

ELECTRICAL COMPONENTS

- ① Wire harness
- ② Starter motor
- ③ CDI unit
- ④ Engine oil level gauge
- ⑤ Starter relay
- ⑥ Fuel level gauge
- ⑦ Battery
- ⑧ Ignition coil

BATTERY SPECIFIC GRAVITY: 1,280
IGNITION COIL: PRIMARY COIL RESISTANCE: 0.56 ~ 0.84 Ω at 20 °C (68 °F) SECONDARY COIL RESISTANCE: 5.7 ~ 8.5 Ω at 20 °C (68 °F)

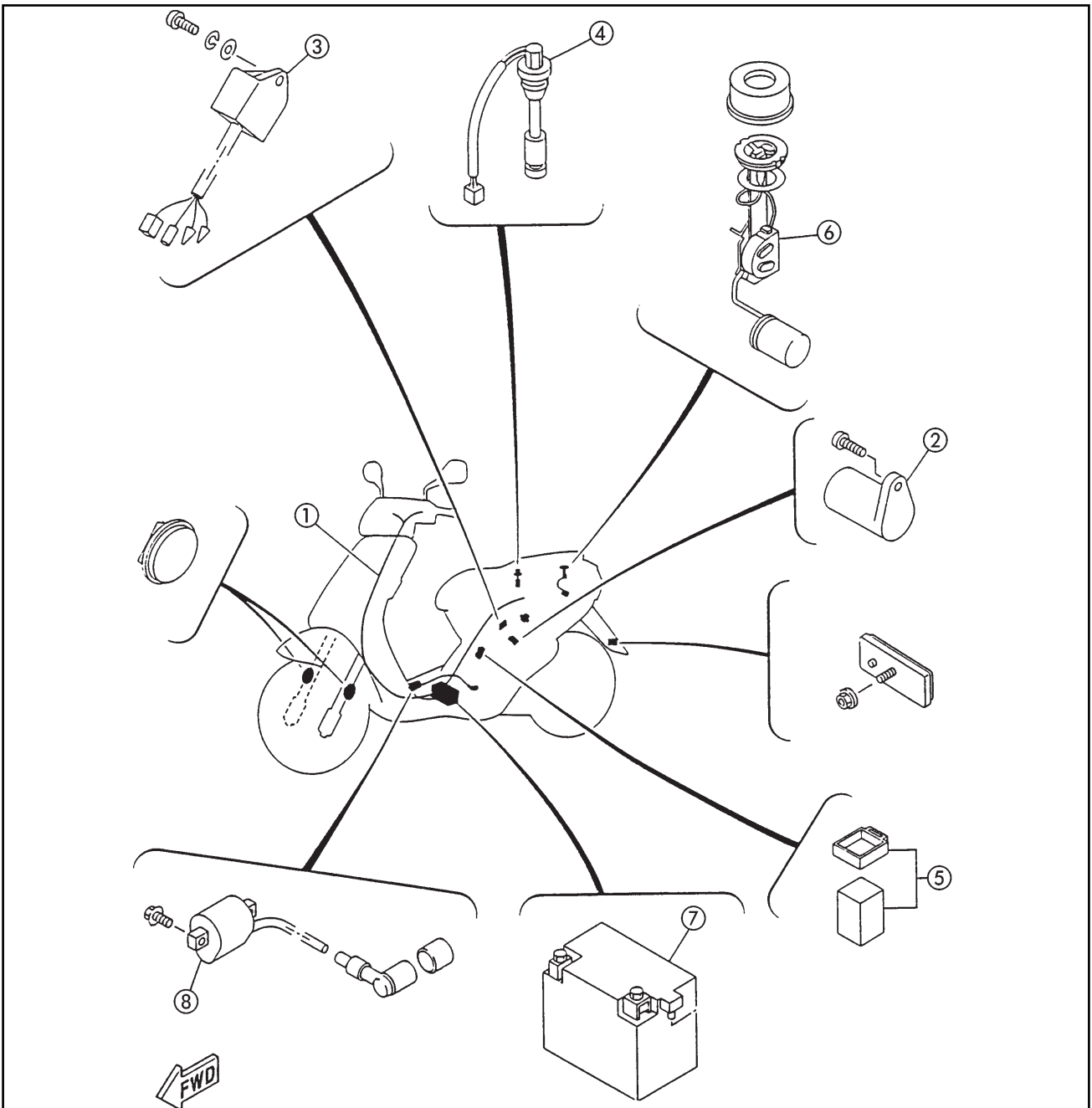

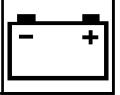

- ① Main switch/seat lock
- ② Turn signal relay
- ③ Rectifier/regulator
- ④ Horn

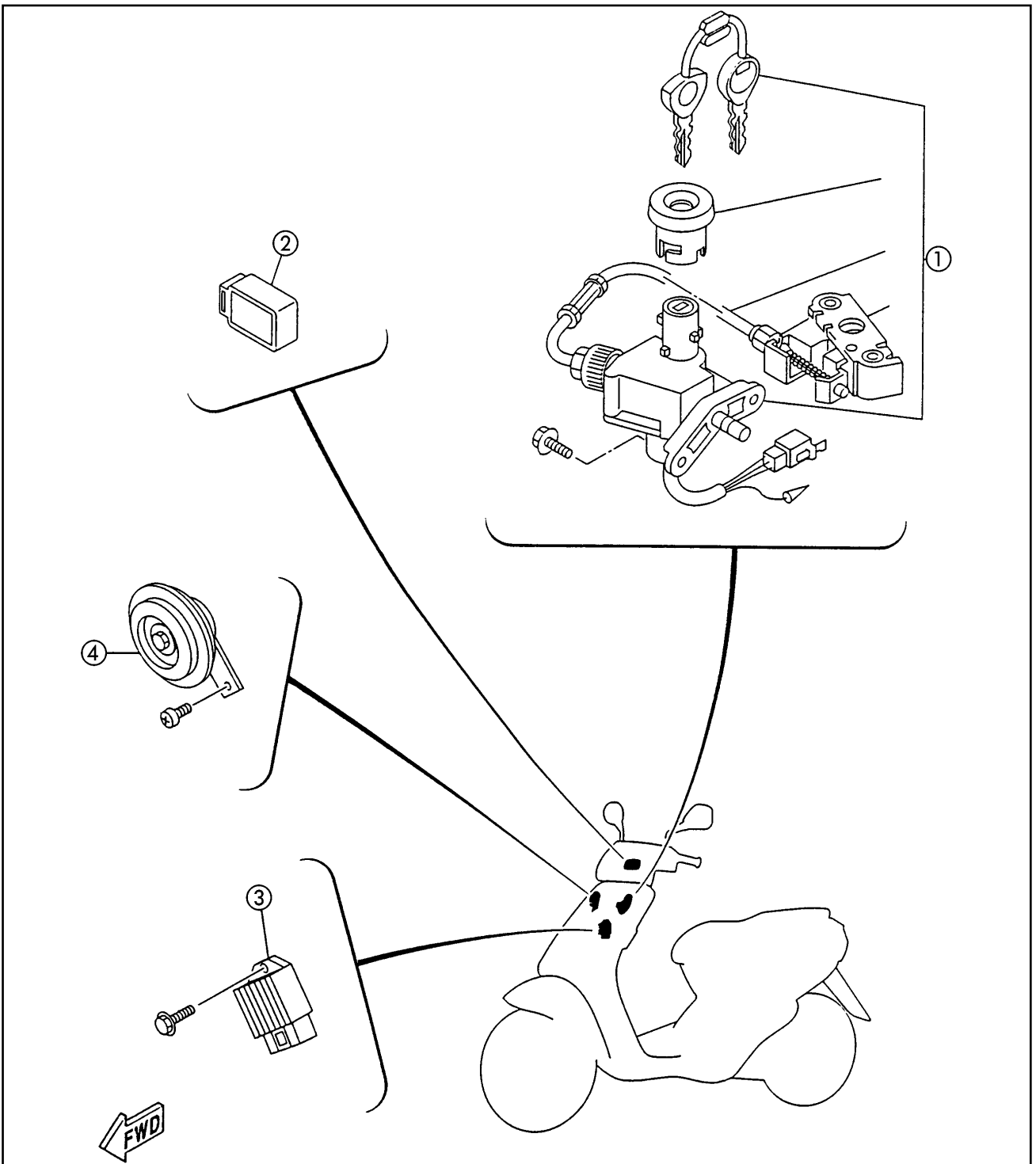

IGNITION AND STARTER SYSTEM

ELEC

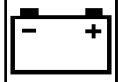

IGNITION AND STARTER SYSTEM CIRCUIT DIAGRAM

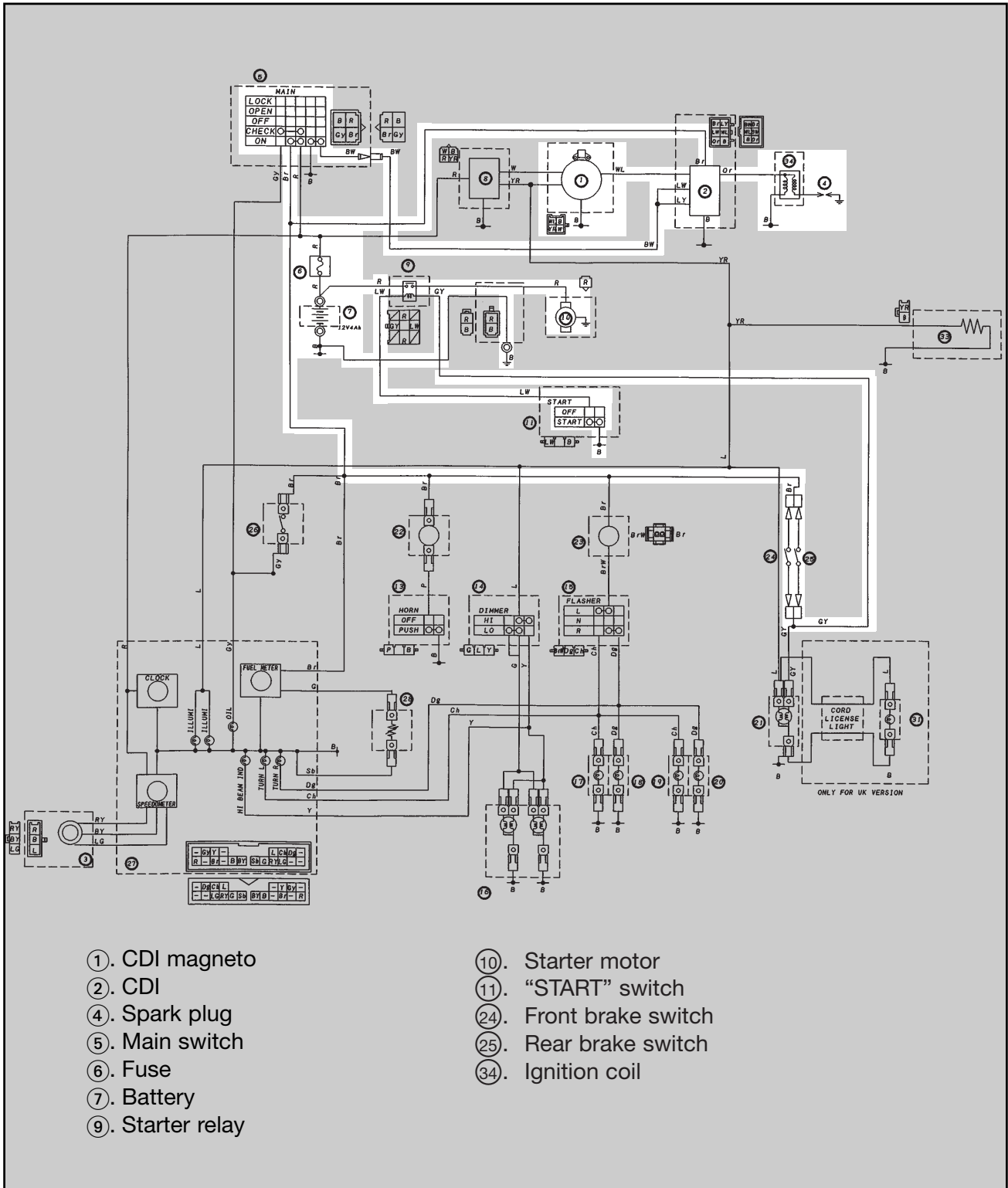

IGNITION AND STARTER SYSTEM

ELEC

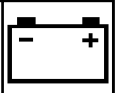

SISTEMA DE ENCENDIDO Y ARRANQUE

- ① Spark plug
- ② Ignition coil
- ④ CDI unit
- ⑦ Starter motor
- ⑧ Starter relay
- ⑨ Fuse
- ⑩ Battery
- ⑪ Starter switch
- ⑫ Main switch
- ⑬ Front brake switch
- ⑭ Rear brake switch
- ⓑ Pick-up coil
- ⓒ To oil level switch

INDUCED COIL RESISTANCE:
0.05 ~ 0.06 Ω at 20 °C (68 °F)

BRUSH WEAR LIMIT:
0.9 mm

COMMUTATOR WEAR LIMIT:
16.6 mm

MICA LOWER CUT-OFF:
1.35 mm

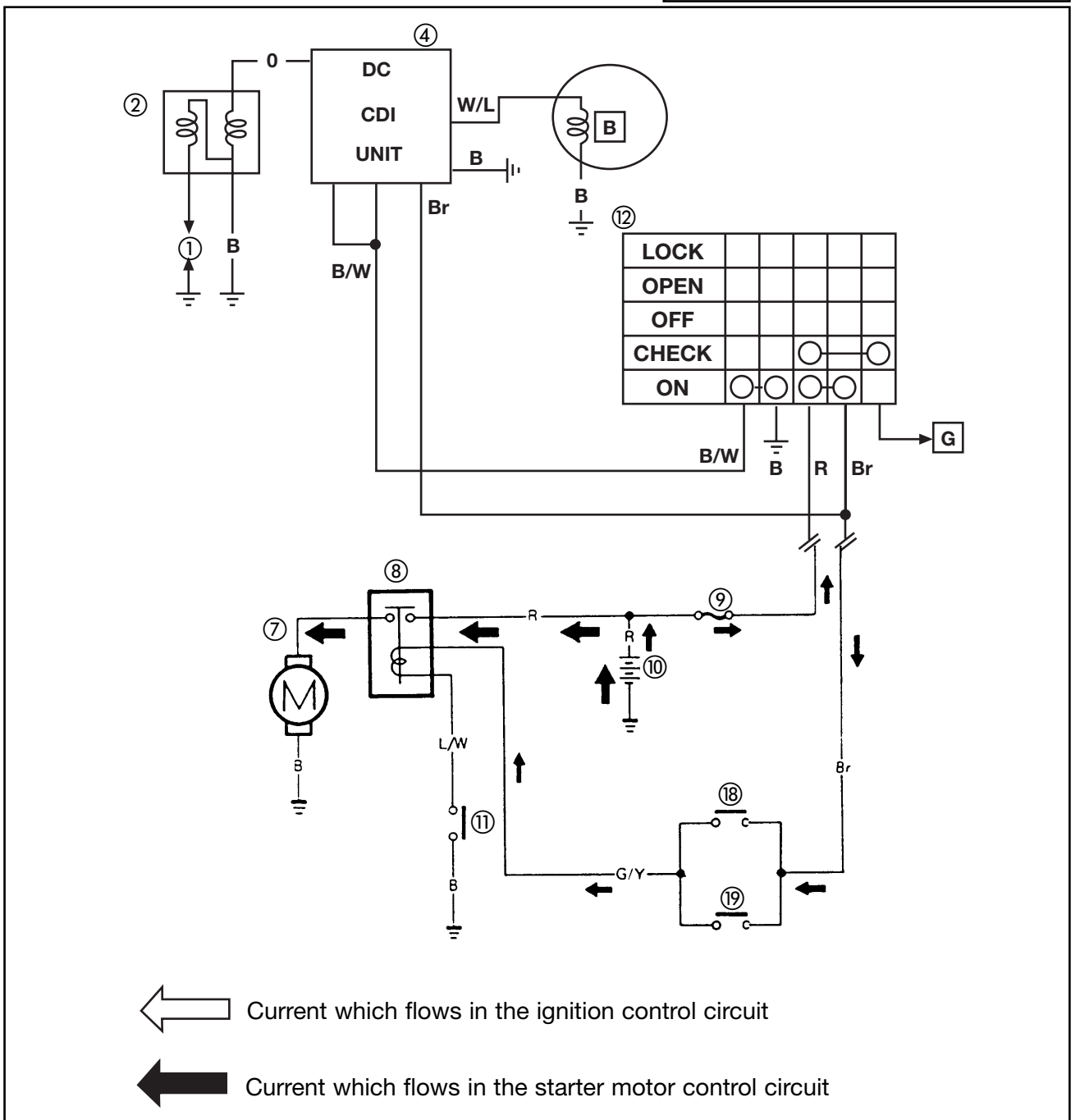

IGNITION AND STARTER SYSTEM

ELEC

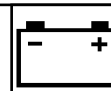

TROUBLESHOOTING

IF THE IGNITION SYSTEM IS NOT OPERATING (NO SPARK OR INTERMITTENT SPARK)

NOTE:

- Remove the following parts before carrying out the repair of fault .
 - 1) Side covers (right and left)
 - 2) Rear cover
 - 3) Footrest panel
- Use the following special tools to repair faults.



Ignition tester:
90890-06754



Pocket tester:
90890-03112

1. Spark plug

- Check spark plug conditions.
- Check type of spark plug.
- Check distance between electrodes .
Consult chapter 3 “INSPECTION OF SPARK PLUG”

**Standard spark plug
BR7HS (NGK)**



**Distance between electrodes
0.6 ~ 0.7 mm**



CORRECT

INCORRECT



Defective spark plug, change or adjust the distance between the electrodes

2. Gap of the ignition spark plug

- Disconnect the spark plug pipe from the spark plug.
- Connect the ignition tester ① as shown.
- ② Spark plug pipe
- ③ Spark gap
- Check spark gap
- Start the engine and increase the spark jump until ignition fails.

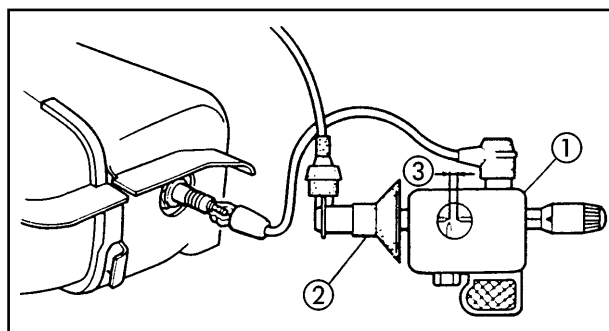

**Minimum spark gap:
6.0 mm**

SATISFIES THE SPECIFIED VALUE



*

OUTSIDE
SPECIFIED
VALUE OR
NO SPARK



The ignition system is in good condition.

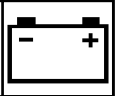

*



3. Spark plug cap resistance

- Remove spark plug cap
- Connect the pocket tester ($\Omega \times 1k$) on the spark plug cap.
- Check if the spark plug pipe has the specified resistance



Resistance of spark plug:
5 k Ω at 20 °C (68 °F)



SATISFIES
THE
SPECIFIED
VALUE

4. Resistance of ignition coil

- Disconnect the ignition coil cables.
- Connect the pocket tester ($\Omega \times 1$) on the ignition coil .

Ignition coil:

Cable (+) of tester → Terminal + (orange)

Cable (-) of tester → Terminal - (ground)

- Check if the primary coil has the specified resistance.



Primary coil resistance:
0.56 ~ 0.84 Ω at 20 °C (68 °F)

- Connect the pocket tester ($\Omega \times 1k$) on the ignition bobbin.

Cable (+) of tester → Cable of spark plug

Cable (-) of tester → Ground

- Check if the secondary coil has the specified resistance.



Secondary coil resistance:
5.7 ~ 8.5 k Ω at 20 °C (68 °F)
(Spark plug cable - Coil cable)



BOTH SATISFY
THE SPECIFIED
VALUE

*

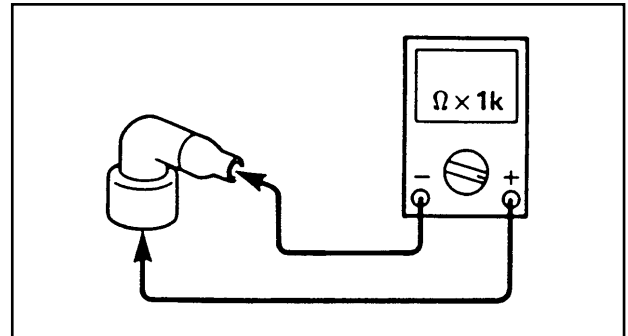

OUTSIDE SPECIFIED VALUE



Replace the spark plug cap

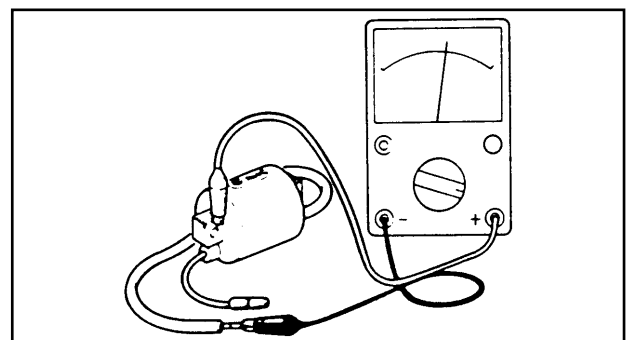
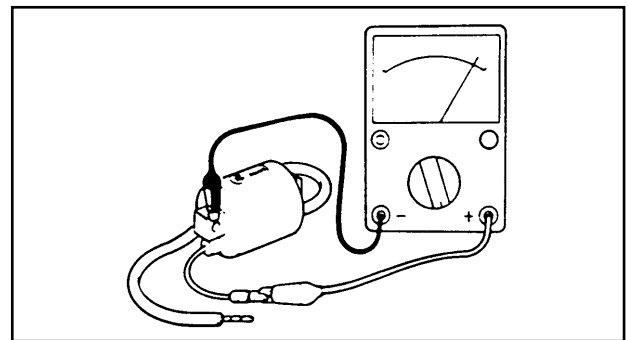

OUTSIDE SPECIFIED VALUE



The ignition coil is defective, replace it

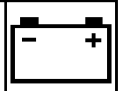

*



5. Pick up coil resistance	
<ul style="list-style-type: none"> • Disconnect the Pick up coil coupler of the installation • Connect the pocket tester ($\Omega \times 100$) on the pick up coil terminal. 	
Cable (+) of tester → White blue Cable (-) of tester → Black	
<ul style="list-style-type: none"> • Check if the pick up coil has the specified resistance. 	
	Resistance of harnessing coil 250 ~ 370 Ω at 20 °C (68 °F)

OUTSIDE SPECIFIED VALUE



The pick up coil is defective, replace it



SATISFIES THE SPECIFIED VALUE

6. Connections
Check the connections throughout the ignition system for connections. Consult the "ELECTRICAL DIAGRAM" section



Correct



CORRECT

Replace the CDI unit.

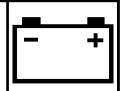

THE STARTER MOTOR DOES NOT FUNCTION

NOTE:

- Remove the following parts before repairing the faults.
 - 1) Side covers (right and left)
 - 2) Rear cover
 - 3) Front mudguard
 - 4) Handlebar cover (upper)
- Use the following special tool for these repairs.



**Pocket tester:
90890-03112**

1. Fuse

- Remove the fuse.
- Connect the pocket tester ($\Omega \times 1$) on the fuse.
- Check the fuse to see if there is continuity.

CONTINUITY

NO CONTINUITY

The fuse is defective

2. Battery

- Check the conditions of the battery. Consult the "INSPECTION OF THE BATTERY" section in chapter 3.

**Open circuit voltage:
12.8 V or more at 20 °C (68 °F)**

CORRECT

INCORRECT

- Clean the battery terminals
- Recharge or change battery.

⚠ WARNING:

- The bridge cable should have the same capacity as the cable or more, otherwise the cable may burn .
- This composition may cause sparks, as a result, ensure that there are no gases or inflammable liquids in the area.

3. Starter motor

- Connect the positive terminal of the battery (1) and the starter motor cable (2) using a bridge cable (3)*

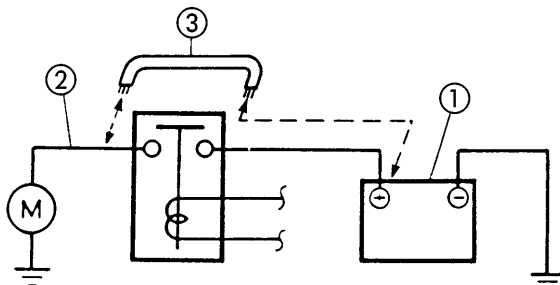

- Check the operation of the starter motor.

STARTER MOTOR
TURNS

STARTER MOTOR DOESN'T TURN

The starter motor is defective, repair or change.

IGNITION AND STARTER SYSTEM

ELEC

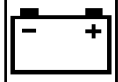

*



4. Starter relay

- Disconnect the starter relay cable from the installation.
- Connect the battery to the starter relay cables as shown using the bridge cables ①.
- Check the operation of the starter motor.

INCORRECT



The main switch is defective, change.



DOES MOVE

5. Main switch

- Disconnect the coupler of the main switch from the installation.
- Check the switch component to see if there is continuity between "Red ① and Brown ②".

DOESN'T MOVE



The starter relay is defective, change



CORRECT

6. Starter switch

- Disconnect the coupler of the handlebar switch (right) from the installation.
- Check the starter switch component to see if there is continuity between "Blue/White ① and Black ②"

INCORRECT



The starter switch is defective, change the handlebar switch (right).



CORRECT

*

7. Connections

- Check the connections throughout the ignition system.
See the "ELECTRICAL DIAGRAM"

BAD CONNECTION



Correct

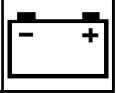

CHARGING SYSTEM CIRCUIT DIAGRAM

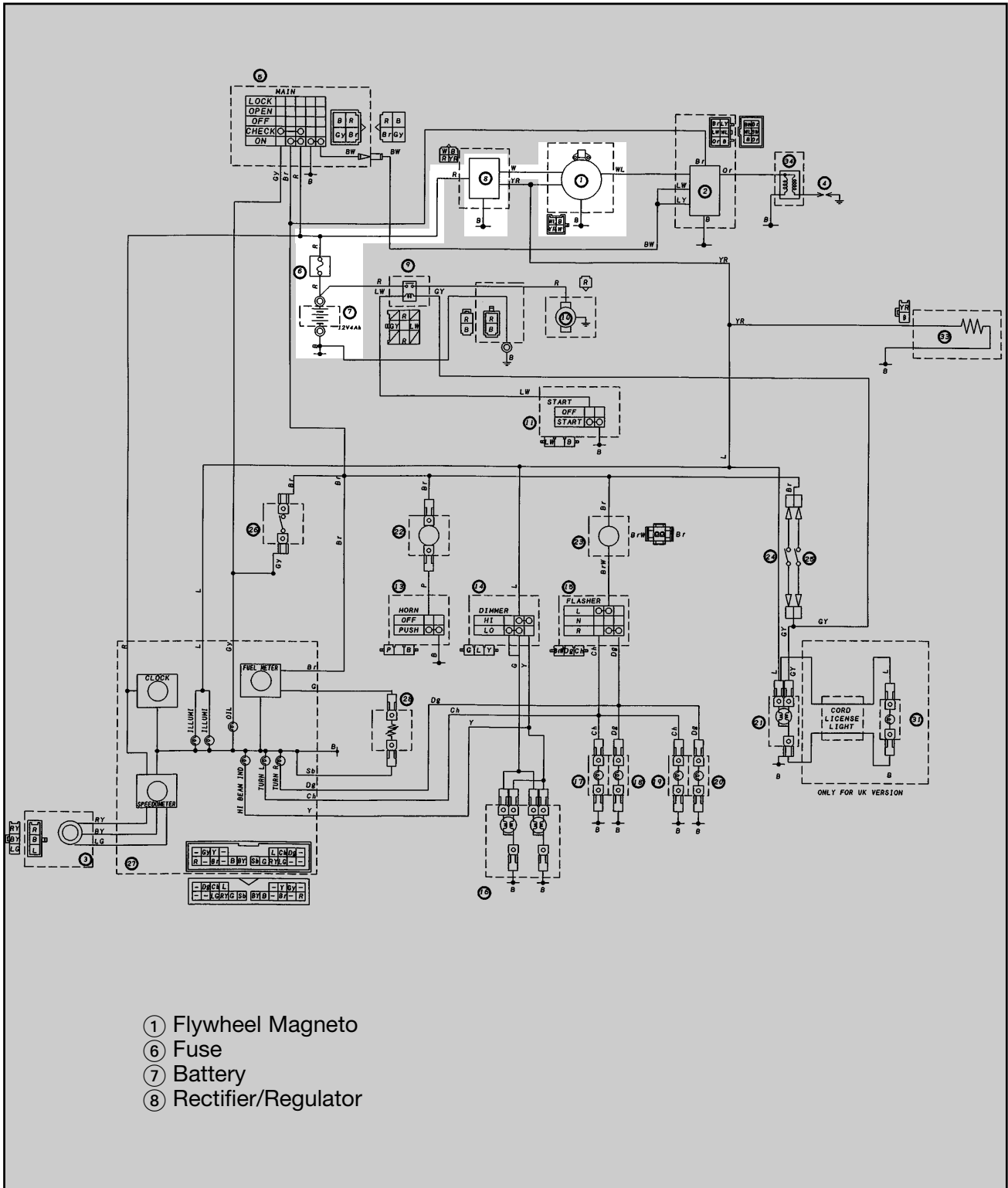

- ① Flywheel Magneto
- ⑥ Fuse
- ⑦ Battery
- ⑧ Rectifier/Regulator

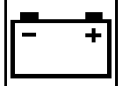

TROUBLESHOOTING

THE BATTERY IS NOT CHARGED

NOTE:

- Remove the following parts before carrying out the repair of the fault.
 - 1) Side covers (right and left)
 - 2) Rear cover
- Use the following special tool for this repair.



Inductive tachometer:
90890-03113



Pocket tester:
90890-03112

1. Fuse (main)

- Remove the fuse.
- Connect the pocket tester ($\Omega \times 1$) to the fuse.
- Check the fuse to see if there is continuity



CONTINUITY

2. Battery

- Check the condition of the battery. See chapter 3, section "INSPECTION OF THE BATTERY".

Open circuit voltage:
12.8 V or more at 20 °C (68 °F)



CORRECT

3. Charging voltage

- Connect the inductive tachometer on the spark plug cable
- Connect the pocket tester (20 V CC) on the battery.

Cable (+) of the tester → Terminal (+)
Cable (-) of the tester → Terminal (-)

- Start the engine and accelerate to 5,000 rpm/min.
- Check charging voltage.



Charging voltage:
14 ~ 15 V at 5,000 rpm/min.

NOTE:

Use a fully charged battery.



OUTSIDE SPECIFIED VALUE

*

NO CONTINUITY

The fuse is defective, change.

INCORRECT

- Clean the battery terminals
- Recharge or change the battery.

SATISFIES THE SPECIFIED VALUE

The charging circuit is in good condition.

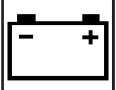

*



4. Charge coil resistance

- Disconnect the charge coil coupler from the installation.
- Connect the pocket tester($\Omega \times 1$) on the charge coils.
- Measure the resistances of the charge coil.

Cable (+) of the tester → White cable ①
Cable (-) of tester → Yellow/Red Cable ②

 Charge coil resistance:
0,288 ~ 0.432 Ω at 20 °C (68 °F)



SATISFIES THE SPECIFIED VALUE

OUTSIDE SPECIFIED VALUE



The charge coil is defective, change

5. Connections

Check the connections throughout the ignition system.
Consult the "ELECTRICAL DIAGRAM" section.



GOOD

BAD CONNECTION



Correct.

Change the rectifier/regulator

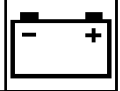

LIGHTING SYSTEM CIRCUIT DIAGRAM

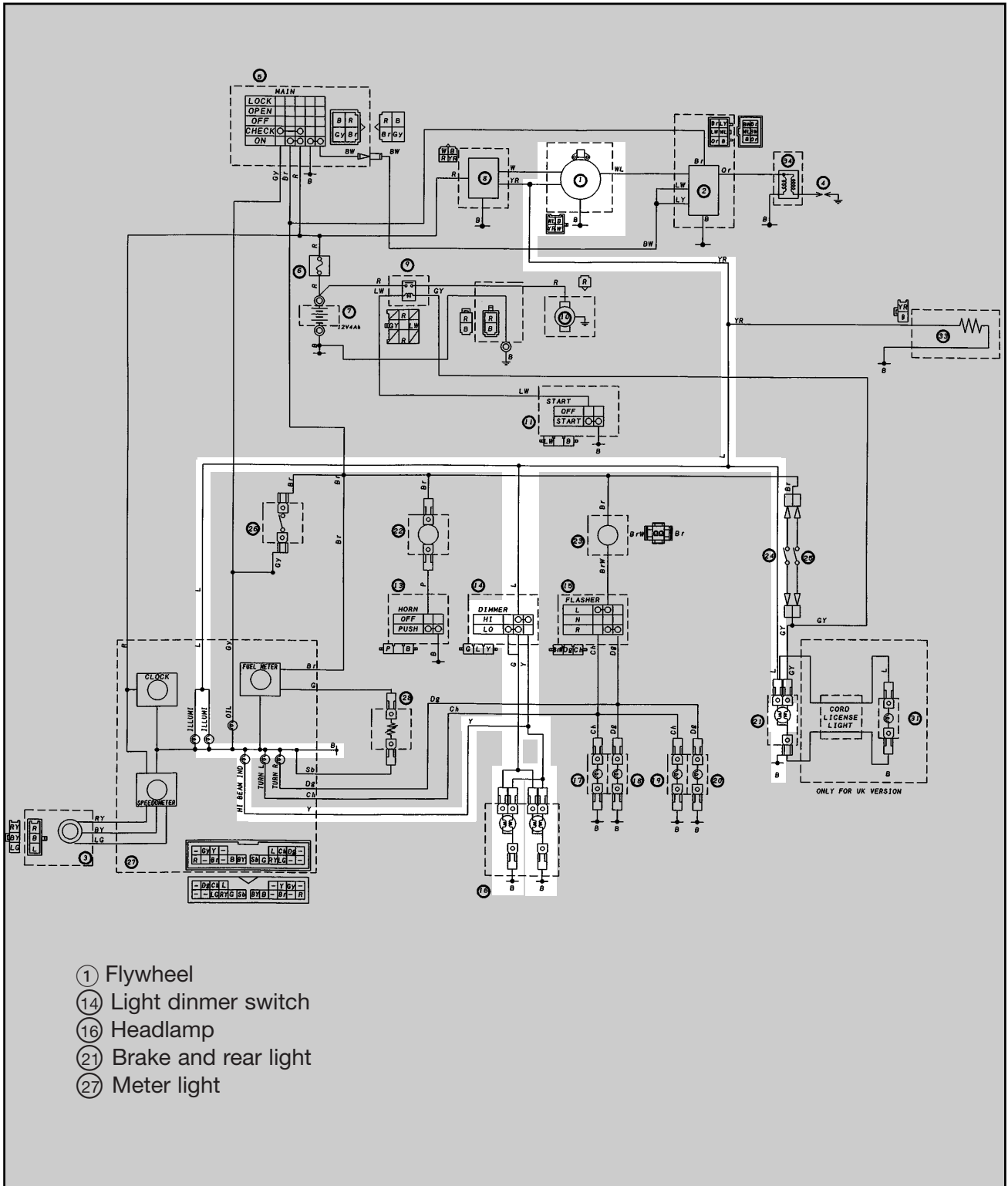

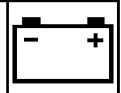

TROUBLESHOOTING

HEADLAMP, "HIGH BEAM" LIGHT INDICATOR, REAR LIGHT AND/OR METER LIGHT DO NOT LIGHT UP

NOTE:

- Remove the following parts before repairing the faults.
 - 1) Side covers (right and left)
 - 2) Rear cover
 - 3) Handlebar cover (upper)
- Use the following special tool for these repairs.



Pocket tester:
90890-03112

1. Light switch “ ”

- Disconnect the coupler of the main switch (left) from the installation.
- Place the switch “ ” in position “ ”.
- Check the switch component to see if there is continuity between “Blue/Yellow” and “Blue/Green ”.

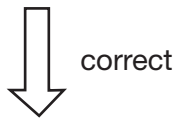

INCORRECT



The “LIGHTS” switch (intensity control) is defective, Change the handlebar switch (left).

2. Resistance of the lighting coil

- Disconnect the lighting coil coupler from the installation
- Connect the pocket tester ($\Omega \times 1$) on the lighting coils.
- Measure the resistances of the lighting coil.

Cable (+) of tester → Yellow/Red
Cable (-) of tester → Ground



Lighting coil resistance:
0,176 ~ 0,264 Ω at 20 °C (68 °F)

OUTSIDE SPECIFIED VALUE



The lighting coil is defective, change.

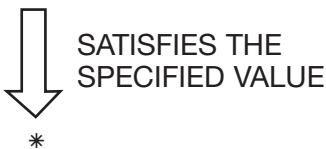

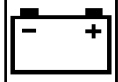

*



3. Connections
 Check the connections throughout the lighting system.
 See "ELECTRICAL DIAGRAM" section



CORRECT

The circuit is in good condition

BAD CONNECTION



Correct

CHECKING LIGHTING SYSTEM

1. The headlight does not light

1. Bulb and bulb holder
 • Check the bulb and bulb holder to see if there is continuity.



CONTINUITY

NO CONTINUITY



Replace the bulb and/or bulb holder.

2. Voltage
 • Connect the pocket tester (20 V AC) on the headlight.
Headlamp light:
Cable (+) of → Yellow or Green
Cable (-) of tester → Black
 [A] When the switch "☰☱☲" (intensity control) is in position "☱".
 [B] When the switch "☰☱☲" (intensity control) is in position "☲".
 • Place the main switch on "O".
 • Start the engine.
 • Place the switch "☰☱☲" (dimmer switch) in position "☱" or "☲".
 • Check if there is a voltage (12 V) in the "Green" and "Yellow" cable in the connectors of the bulb holder.



SATISFIES THE SPECIFIED VALUE (12 V)

The circuit is in good condition.

OUTSIDE SPECIFIED VALUE



The connection circuit of the main switch to the bulb holder connector is defective, repair it.

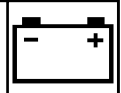

2. The panel light does not light.

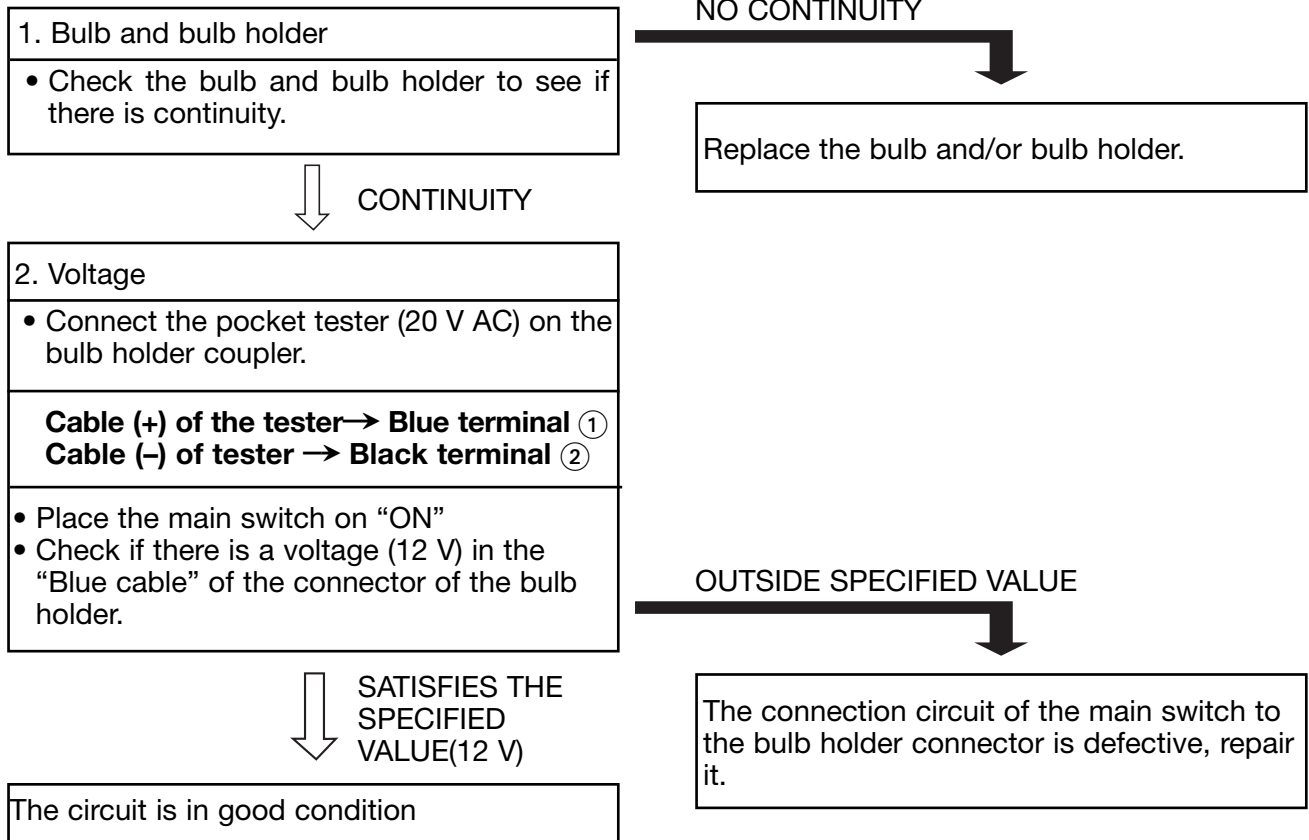

3. The rear light does not light.

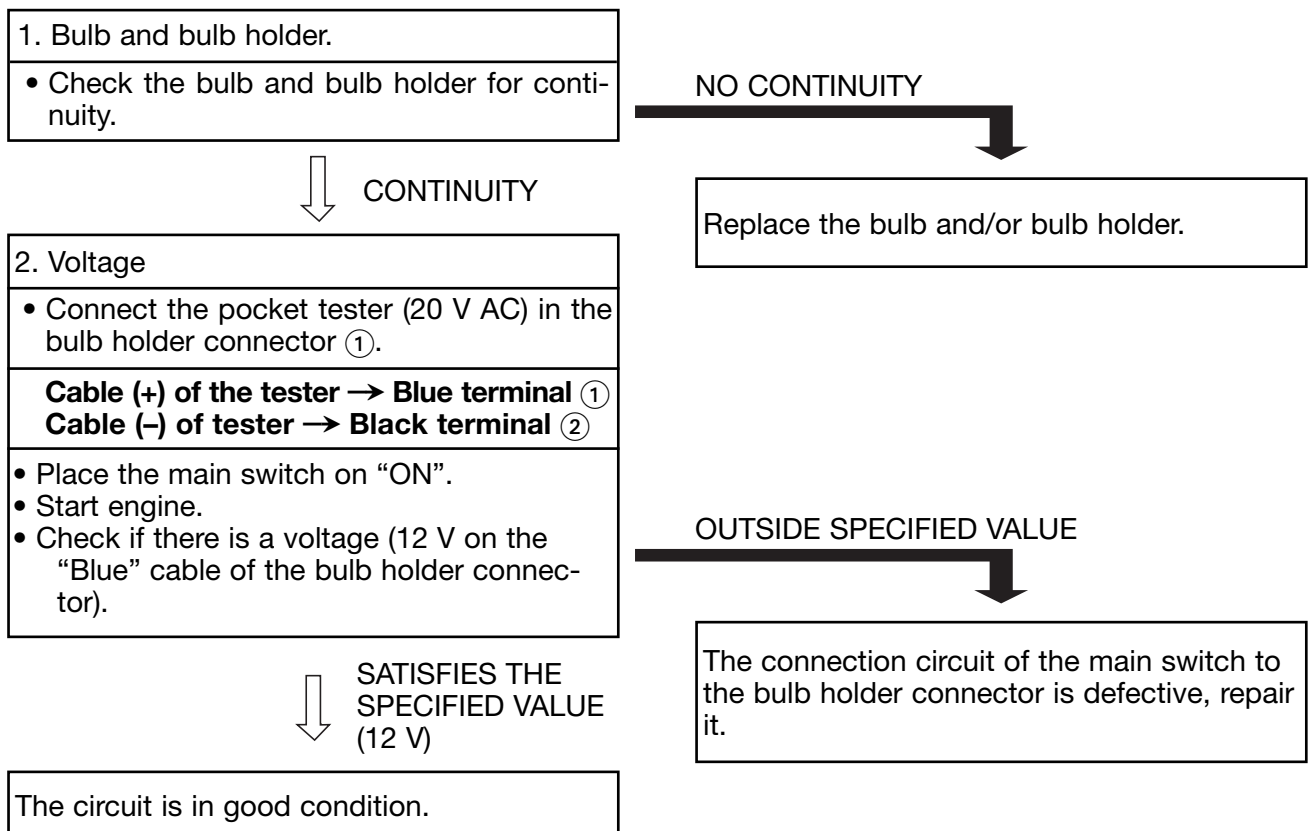

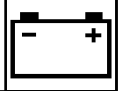

SIGNALLING SYSTEM CIRCUIT DIAGRAM

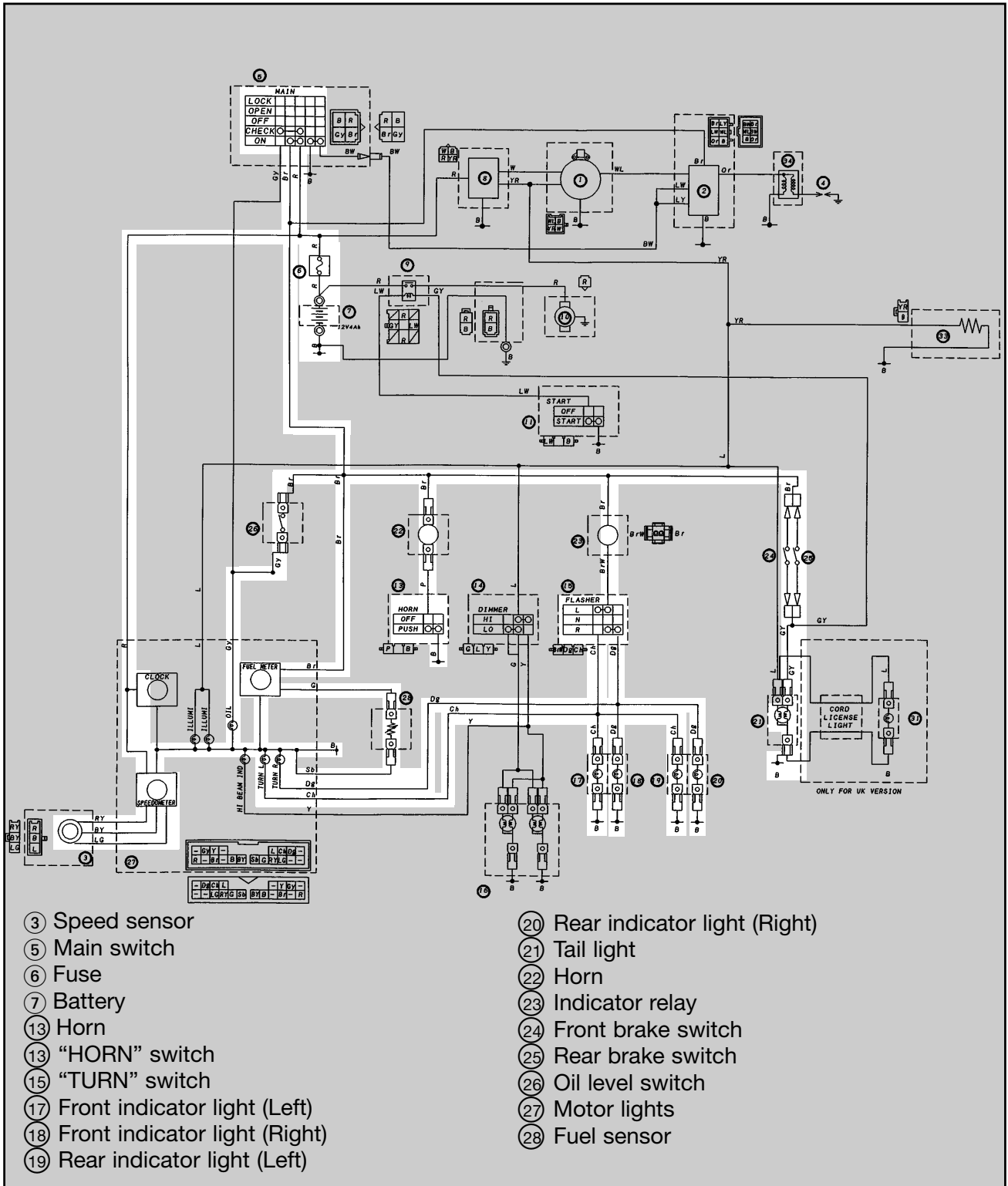

- ③ Speed sensor
- ⑤ Main switch
- ⑥ Fuse
- ⑦ Battery
- ⑬ Horn
- ⑬ "HORN" switch
- ⑮ "TURN" switch
- ⑰ Front indicator light (Left)
- ⑱ Front indicator light (Right)
- ⑲ Rear indicator light (Left)
- ⑳ Rear indicator light (Right)
- ㉑ Tail light
- ㉒ Horn
- ㉓ Indicator relay
- ㉔ Front brake switch
- ㉕ Rear brake switch
- ㉖ Oil level switch
- ㉗ Motor lights
- ㉘ Fuel sensor

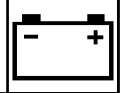

TROUBLESHOOTING

- INDICATOR LIGHT, BRAKE LIGHT, AND/OR INDICATING LIGHTS DO NOT LIGHT.
- THE HORN DOES NOT SOUND

NOTE:

- Remove the following parts before repairing the faults .
 - 1) Front cover .
 - 2) Inner cover
 - 3) Rear panel (battery box)
 - 4) Front lower fender
- Use the following special tool for the repairs.



Pocket tester:
90890-03112

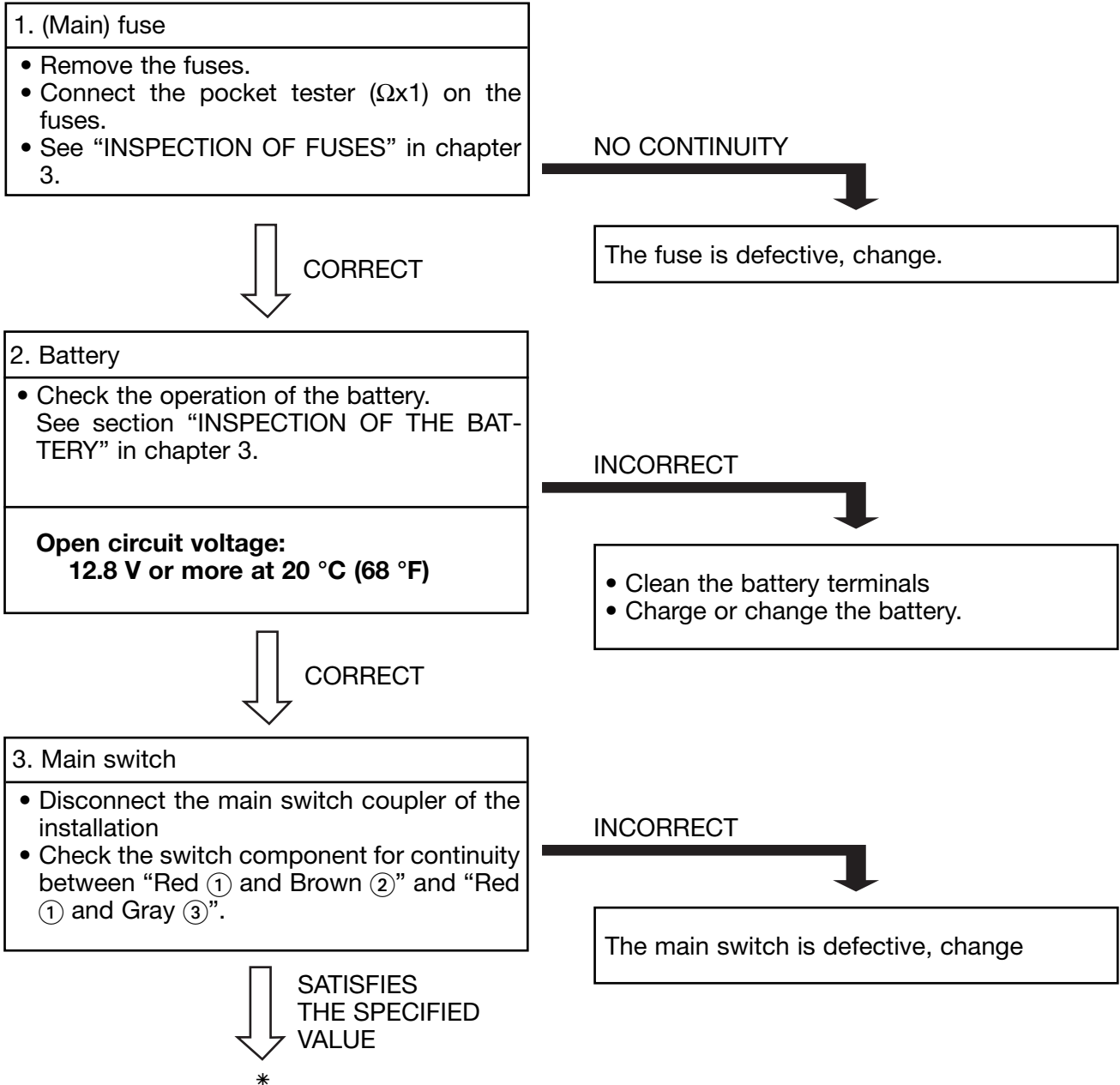

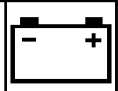

*



4. Connections

- Check the connections throughout the signalling system.
- See the “ELECTRICAL DIAGRAM” section



CORRECT

Check the conditions for each signalling system circuit.
Consult the “CHECKING SIGNALLING SYSTEM” section.

BAD CONNECTION

Repair

CHECKING SIGNALLING SYSTEM

1. Horn does not operate

1. “HORN” switch.

- Disconnect the coupler of the handlebar switch (left) from the installation and horn cable.
- Check the switch component for continuity between “Black ① and Red ②”.



CORRECT

INCORRECT

The “HORN” switch is defective, change the handlebar switch (left).

2. Voltage

- Connect the pocket tester (20 V DC) on the horn cable.

Cable (+) of the tester → Brown ①
Cable (-) of tester → Frame earth

- Place the main switch on “ON”
- Check if there is a voltage (12 V) in the brown cable of the horn terminal.

OUTSIDE SPECIFIED VALUE

The connection circuit from the main switch to the horn terminal is defective, repair.



SATISFIES THE SPECIFIED VALUE (12 V)

*

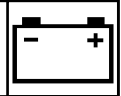

*



3. Horn
<ul style="list-style-type: none"> • Disconnect the “Pink” cable from the horn terminal. • Connect a bridge cable ① on the horn terminal and earth the bridge cable. • Place the main switch on “ON”.

THE HORN SOUNDS

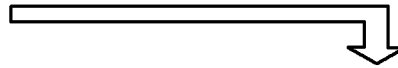

The horn is in good condition.



THE HORN DOES NOT SOUND.

4. Voltage
<ul style="list-style-type: none"> • Connect the pocket tester (20 V DC) on the horn, on the “Pink” terminal.
<p>Cable (+) of tester → Pink ① Cable (-) of tester → Earth of frame</p>
<ul style="list-style-type: none"> • Place main switch on “ON”. • Check if there is a voltage (12 V) in the “Pink” cable on the horn terminal.

OUTSIDE SPECIFIED VALUE



The horn is defective.



SATISFIES THE SPECIFIED VALUE

Adjust the horn.

2.The brake lights do not light.

1.Bulb and bulb holder.
<ul style="list-style-type: none"> • Check the bulb and bulb holder for continuity

NO CONTINUITY



Change the bulb and/or bulb holder.



CONTINUITY

2.Brake switch
<ul style="list-style-type: none"> • Disconnect the brake switch cables from the installation. • Check the switch component for continuity between “Brown ① and Green/Yellow ②”.

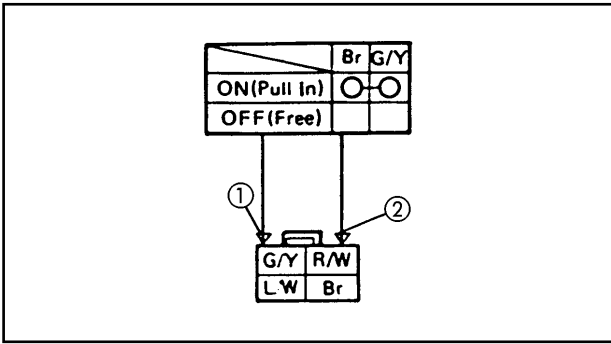

INCORRECT

The brake switch is defective, change.

CORRECTO

3. Voltage

- Connect the pocket tester (20 V DC) on the bulb holder connector.

Cable (+) of tester → Green/Yellow ①
 Cable (-) of tester → Black ②

- Place the main switch on “ON”.
- Activate the brake lever.
- Check if there is a voltage (12 V) on the “Green/Yellow” cable of the bulb holder connector.

OUTSIDE SPECIFIED VALUE

The connection circuit from the main switch to the connector of the bulb holder is defective, change.

SATISFIES THE SPECIFIED VALUE (12 V)

The circuit is in good condition.

3. The Master lights do not flash.

1. Bulb and bulb holder.

- Check the bulb and bulb holder for continuity.

NO CONTINUITY

Change the bulb and/or bulb holder.

CONTINUITY

2. Turning signal switch “↔”

- Disconnect the handlebar switch coupler (left) from the installation.
- Check the switch component for continuity between “Brown/white” ① and “Chocolate ②” and “Brown/White” ① and “Dark green” ③

CORRECT

*

SIGNALLING SYSTEM

ELEC

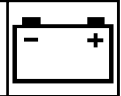

*



3. Voltage
<ul style="list-style-type: none"> Connect the pocket tester (20 V DC) on the flasher relay .
Cable (+) of tester → Brown Cable (-) of tester → Fame ground
<ul style="list-style-type: none"> Place the main switch on "ON". Check if there is a voltage (12 V) on the "Brown" cable and "Frame ground" of the flasher relay terminal.



SATISFIES THE SPECIFIED VALUE (12 V)

4. Voltage
<ul style="list-style-type: none"> Connect the pocket tester (20VDC) on the flaster relay.
Cable (+) of tester → White/Brown Cable (-) of tester → Frame ground
<ul style="list-style-type: none"> Place the main switch on "ON" Chek it there is a vollàge (12V) on the "Brown / White" cable and "Frame ground" of the flasher relay terminal.



SATISFIES THE SPECIFIED VALUE (12V)

5. Voltage
<ul style="list-style-type: none"> Connect the pocket tester (20 V DC) on the bulb holder receptacle.
On the indicator light (left): Cable (+) of the tester → Chocolate ① Cable (-) of tester → Frame ground
On the indicator light (right): Cable (+) of tester → Dark Green ② Cable (-) of tester → Frame ground

INCORRECT



The "TURN" is defective, change the hand-lebar switch (left).

OUTSIDE SPECIFIED VALUE



The indicator relay is defective, change

OUTSIDE SPECIFIED VALUE



The flasher relay is faulty, change

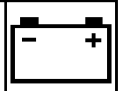

- Place the main switch on “○”.
- Place the switch “↔” on position “←” or “→”.
- Check if there is a voltage (12 V) on the “Chocolate” or “Dark Green” cable of the bulb holder connector.

↓ SATISFIES THE SPECIFIED VALUE (12 V)

The circuit is in good condition.

OUTSIDE SPECIFIED VALUE

The connection circuit from the “TURN” switch to the bulb holder connector is defective, review.

4. The oil indicator light “OIL” does not light.

1. Bulb and bulb holder
- Check the bulb and bulb holder for continuity.

↓ CONTINUITY

NO CONTINUITY

Change the bulb and/or bulb receptacle.

2. Oil level switch
- Remove the oil sump oil level switch.
 - Connect the pocket tester ($\Omega \times 1$) on the oil level switch.

Cable (+) of tester → Terminal ①
Cable (-) of tester → Terminal ②

- Check the oil level measurer for continuity.

Switch position	Good condition	Bad condition		
		○	x	○
A Vertical position upwards	x	○	x	○
B Reverse position	○	x	x	○

○: Continuity x: No continuity

↓ GOOD CONDITION

POOR CONDITION

Change the oil level switch.

3. Voltage
- Connect the pocket tester (20 V DC) on the bulb holder connector .
- Cable (+) of tester → Gray ①**
Cable (-) of tester → Frame ground

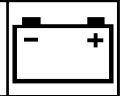

- Place main switch on “*”
- Check if there is a voltage (12 V) on the “Gray” cable of the bulb holder connector

↓ SATISFIES THE SPECIFIED VALUE (12 V)

The circuit is in good condition.

OUTSIDE SPECIFIED VALUE

4. Connections

- Check the connections throughout the signalling system. See the “ELECTRICAL DIAGRAM” section.

5. The speedometer fails to come on.

1. Voltage

- Connect the pocket tester (DC 20 V) to the multi-function meter socket coupler (wire harness side) as shown.

Positive tester probe → red/yellow ①

Negative tester probe → black/yellow ②

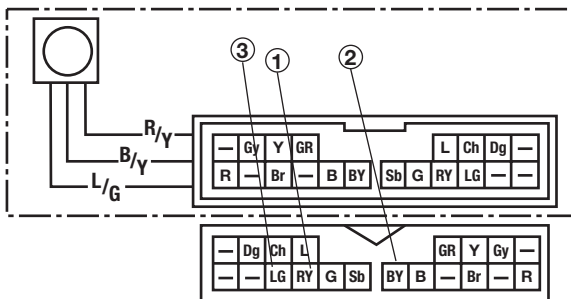

- Set the main switch to “ON”.
- Measure the voltage (DC 12 V) of red/yellow ① on the multi-function meter coupler (wire harness side).
- Is the voltage within specification?

↓ YES

This circuit is OK.

↓ NO

Replace the speed sensor.

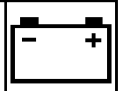

2. Speed sensor

- Connect the pocket tester (DC 20 V) to the speed sensor coupler (wire harness side) as shown.

Positive tester probe → blue/green ①
Negative tester probe → black/yellow ②

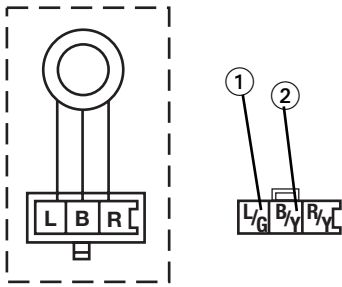

- Set the main switch to “ON”.
- Elevate the front wheel and slowly rotate it.
- Measure the voltage (DC 12 V) of red/yellow and black/yellow. With each full rotation of the front wheel, the voltage reading should cycle from 0 V to 5 ~ 11V to 0 V to 5 ~ 11V, etc.
- Does the voltage reading cycle correctly?

↓ YES

The circuit is OK.

↓ NO

Replace the speed sensor.

?

**LOC
AVER**

8

CHAPTER 8
LOCATION AND REPAIR OF BREAKDOWNS

LOCATION AND REPAIR OF ENGINE BREAKDOWNS	8-1
ELECTRICAL SYSTEM	8-1
COMPRESSION SYSTEM	8-2
INLET AND EXHAUST SYSTEM	8-3

ELECTRICAL DIAGRAM YN50

ELECTRICAL SYSTEM

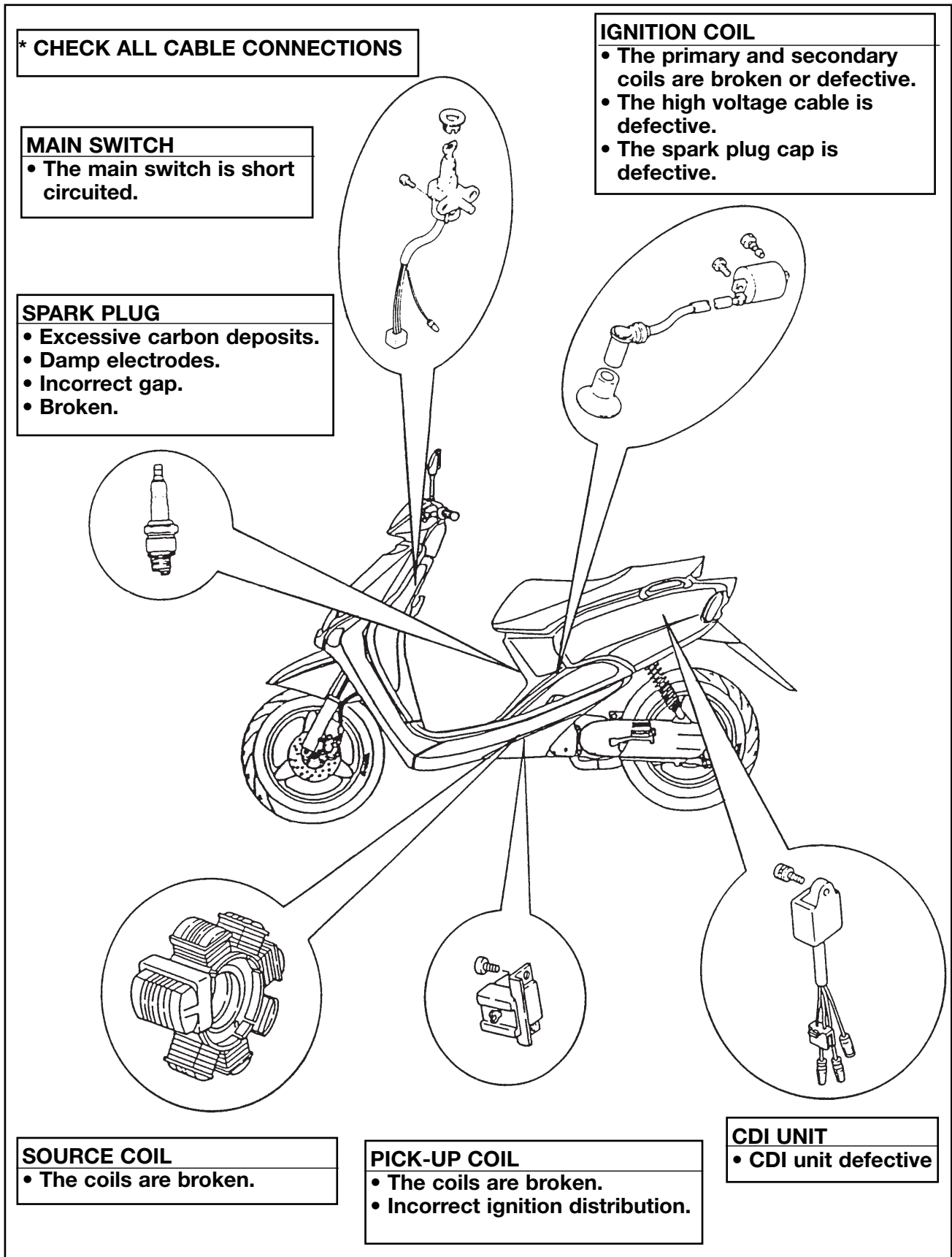

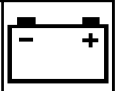

COMPRESSION SYSTEM

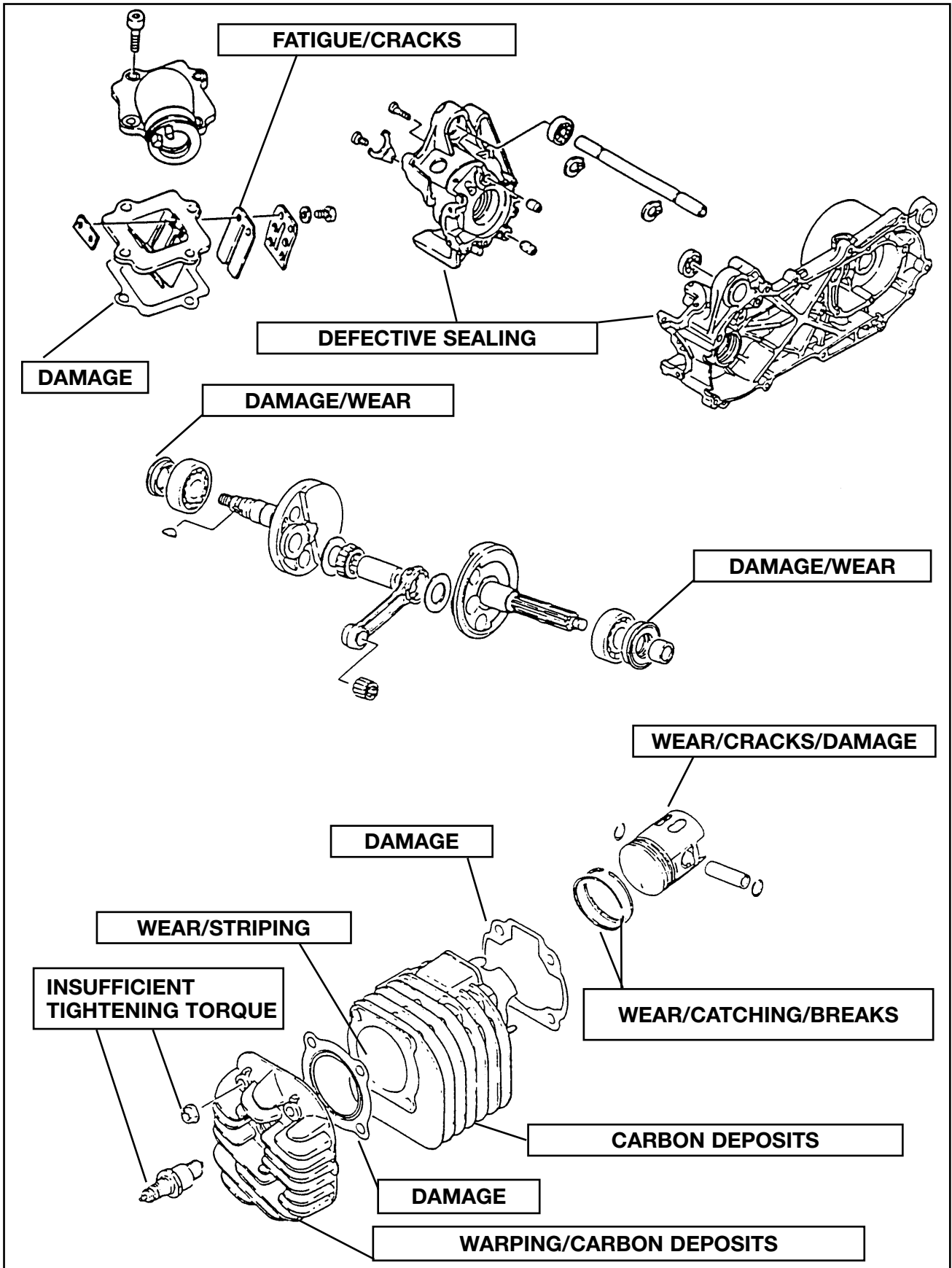

INLET AND EXHAUST SYSTEM

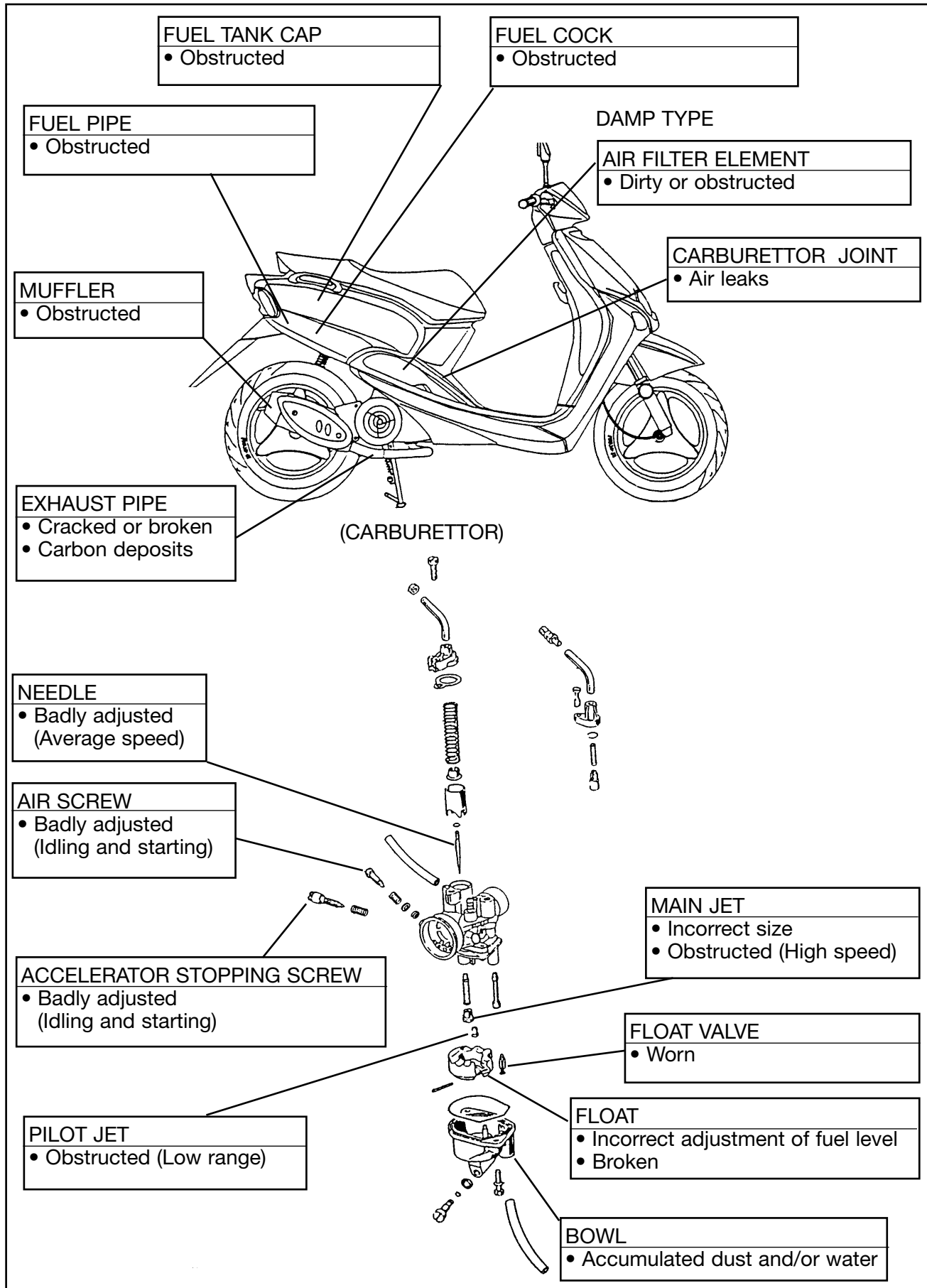

ELECTRICAL DIAGRAM YN50

COLOUR CODE

B	BLACK
R	RED
L	BLUE
G	GREEN
O	ORANGE
Y	YELLOW
P	PINK
BR	BROWN
CH	CHOCOLATE
SB	SKY BLUE
DG	DARK GREEN
W	WHITE
B/BR	BLACK/BROWN
B/Y	BLACK/YELLOW
B/R	BLACK/RED
B/W	BLACK/WHITE
G/R	GREEN/RED
G/Y	GREEN/YELLOW
BR/W	BROWN/WHITE
W/R	WHITE/RED
W/B	WHITE/BLACK
W/G	WHITE/GREEN
Y/L	YELLOW/BLUE
Y/R	YELLOW/RED
L/B	BLUE/BLACK
L/W	BLUE/WHITE
L/Y	BLUE/YELLOW
R/Y	RED/YELLOW
L/G	BLUE/GREEN

COMPONENTS

1. Flywheel magneto
2. CDI UNIT
3. SPEED SENSOR
4. Spark plug
5. Main switch
6. Fuse
7. Battery
8. Rectifier/regulator
9. Starter relay
10. Starter motor
11. Starter switch
13. Horn switch
14. Dimmer switch
15. Turn lights switch
16. Headlight
17. Front left turn light
18. Front right turn light
19. Rear left turn light
20. Rear right turn light
21. Tail light
22. Horn
23. Turn lights relay
24. Front stop switch
25. Rear stop switch
26. Oil level switch
27. Instrument panel
28. Fuel sender
31. License light (UK only)
33. Auto choke
34. Ignition coil

