



YAMAHA

OWNER'S MANUAL

CRYPTON

5AV-F8199-E1

**T105E/SE
OWNER'S MANUAL
© 2003 by Yamaha Motor Co, Ltd.
Manufacturing
1st edition, July 2003
All rights reserved.
Any reprinting or unauthorized use
without the written permission of
Yamaha Motor Co, Ltd.
is expressly prohibited.
Printed in China**

INTRODUCTION

Congratulations on your purchase of the Yamaha T105E/SE. This model is the result of Yamaha's vast experience in the production of fine sporting, touring, and pacesetting racing machines. It represents the high degree of craftsmanship and reliability that have made Yamaha a leader in these fields. This manual will give you an understanding of the operation, inspection, and basic maintenance of this motorcycle. If you have any questions about the operation or maintenance of your motorcycle, please consult a Yamaha dealer.

Particularly important information is distinguished in this manual by the following notations:



The Safety Alert Symbol means ATTENTION! BECOME ALERT! YOUR SAFETY IS INVOLVED!

⚠️ WARNING

Failure to follow WARNING instructions could result in severe injury or death to the motorcycle operator, a bystander or a person inspecting or repairing the motorcycle.

CAUTION:

A CAUTION indicates special precautions that must be taken to avoid damage to the motorcycle.

NOTE:

A NOTE provides key information to make procedures easier or clearer.

NOTE:

- Yamaha continually seeks advancements in product design and quality. Therefore, while this manual contains the most current product information available at the time of printing, there may be minor discrepancies between your machine and this manual. If there is any question concerning this manual, please consult your Yamaha dealer.
- This manual should be considered a permanent part of this motorcycle and should remain with it even if the motorcycle is subsequently sold.

⚠️ WARNING

PLEASE READ THIS MANUAL CAREFULLY AND COMPLETELY BEFORE OPERATING THIS MOTORCYCLE.

CONTENTS

GIVE SAFETY THE RIGHT OF WAY	5	Steering lock.....	19
GENERAL NOTE.....	6	Seat	20
DESCRIPTION.....	8	Helmet holder	21
MOTORCYCLE IDENTIFICATION.....	9	Side cover removal.....	21
Identification numbers record	9	PRE-OPERATION CHECKS	22
Key identification number	10	Fuel.....	24
Frame serial number	10	Engine oil.....	25
Engine serial number	10	Tires.....	26
CONTROL FUNCTIONS.....	11	OPERATION AND IMPORTANT	
Main switch	11	RIDING POINTS.....	28
Indicator lights	12	Starting and warming up a	
Instrument panel.....	13	cold engine	28
Handlebar switches	14	Starting a warm engine	30
Shift pedal	16	Shifting.....	31
Front brake lever	16	To start out and accelerate.....	31
Rear brake pedal	17	To decelerate	33
Fuel tank cap	17	Engine break-in	34
Starter lever ↘	18	Parking	36
Kick starter	18		

PERIODIC MAINTENANCE AND MINOR REPAIR.....	37	Drive chain slack adjustment	57
Tool kit.....	38	Drive chain lubrication	59
Periodic maintenance/lubrication	39	Brake lever and pedal.....	60
Engine oil	41	Center and sidestand	60
Air filter	44	Front fork inspection	61
Throttle cable adjustment.....	46	Battery.....	62
Carburetor adjustment.....	47	Replenishing the battery fluid	64
Idle speed adjustment.....	47	Fuse replacement	65
Spark plug inspection	48	Troubleshooting.....	66
Front brake adjustment(T105E).....	50	CLEANING AND STORAGE	67
Front brake adjustment (T105SE)	50	Cleaning.....	67
Checking the front brake pads (T105SE)	51	Storage	67
Checking the brake fluid level (T105SE).....	51	SPECIFICATIONS	69
Changing the brake fluid (T105SE)	53		
Rear brake adjustment	54		
Brake light switch adjustment.....	55		
Checking the brake shoes	55		
Drive chain slack check	56		

GIVE SAFETY THE RIGHT OF WAY

Motorcycles are fascinating vehicles, which can give you an unsurpassed feeling of power and freedom. However, they also impose certain limits, which you must accept; even the best motorcycle does not ignore the laws of physics.

Regular care and maintenance are essential for preserving your motorcycle's value and operating condition. Moreover, what is true for the motorcycle is also true for the rider: good performance depends on being in good shape. Riding under the influence of medication, drugs and alcohol is, of course, out of the question. Motorcycle riders - more than car drivers - must always be at their mental and physical best. Under the influence of even small amounts of alcohol, there is a tendency to take dangerous risks.

Protective clothing is as essential for the motorcycle rider as seat belts are for car drivers and passengers. Always wear a complete motorcycle suit (whether made of leather or tear-resistant synthetic materials with protectors), sturdy boots, motorcycle gloves and a properly fitting helmet. Optimum protective wear, however, should not encourage carelessness. Though full-coverage helmets and suits, in particular, create an illusion of total safety and protection, motorcyclists will always be vulnerable. Riders who lack critical self-control run the risk of going too fast and are apt to take chances. This is even more dangerous in wet weather. The good motorcyclist rides safely, predictably and defensively - avoiding all dangers, including those caused by others. Enjoy your ride!

GENERAL NOTE

Much can be gained from the correct use and maintenance of a motorcycle.

1 THE CUSTOMERS CAN USE THE FULLEST POTENTIAL OF YAMAHA MOTORCYCLES

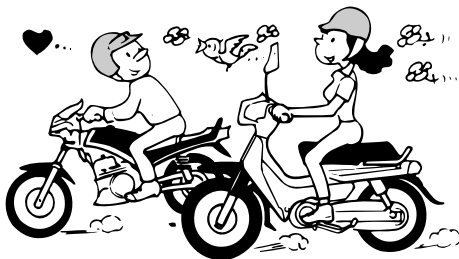

2 A MOTORCYCLE CAN KEEP ITS PERFORMANCE CAPABILITY FOR A LONGER TIME

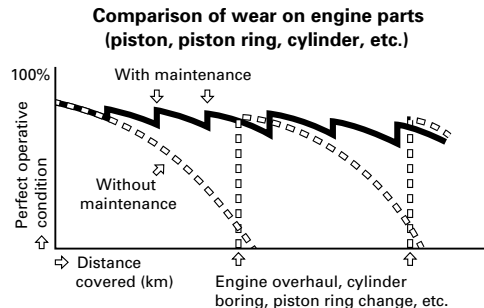

GENERAL NOTE

3 FUEL COST AND REPAIR EXPENSES CAN BE KEPT TO A MINIMUM

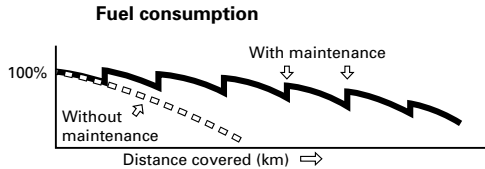

Customer's running cost (fuel cost plus maintenance and repair expenses)

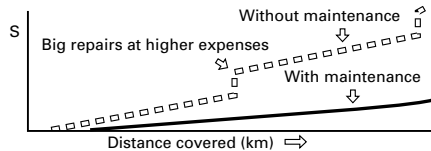

4 A MOTORCYCLE CAN DEMAND A HIGH PRICE WHEN IT IS TRADED IN AS A USED PRODUCT

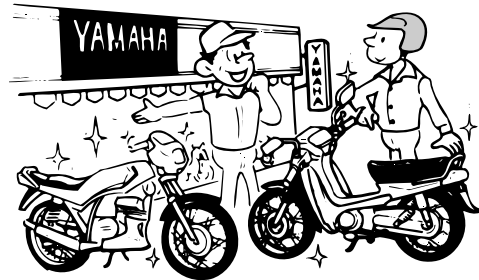

DESCRIPTION

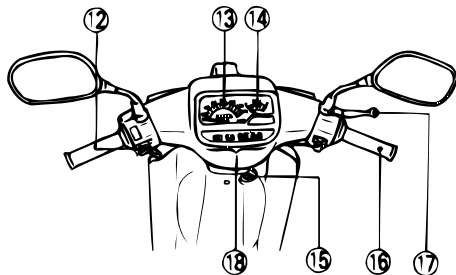
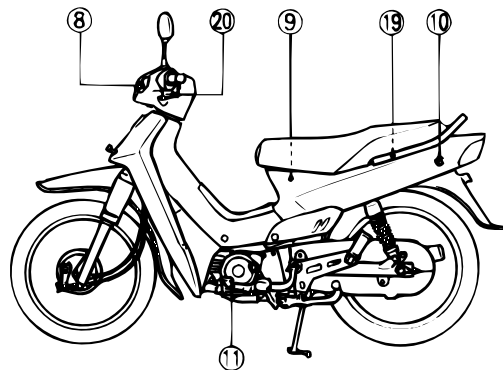
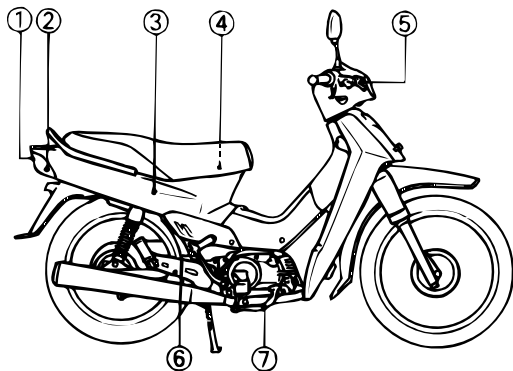

- | | |
|------------------------|-------------------------------|
| 1. Tail/Brake light | 11. Shift pedal |
| 2. Rear flasher light | 12. Handlebar switch |
| 3. Side cover | 13. Speedometer |
| 4. Fuel tank cap | 14. Fuel gauge |
| 5. Front flasher light | 15. Main switch/steering lock |
| 6. Kick starter | 16. Throttle grip |
| 7. Rear brake pedal | 17. Front brake lever |
| 8. Head light | 18. Indicator light |
| 9. Fuel tank | 19. Helmet holder |
| 10. Seat lock | 20. Starter lever |

MOTORCYCLE IDENTIFICATION

1. KEY IDENTIFICATION NUMBER:

2. FRAME SERIAL NUMBER:

3. ENGINE SERIAL NUMBER:

EAA61101

Identification numbers record

Record the key identification number, frame serial number and engine serial number in the spaces provided for assistance when ordering spare parts from a Yamaha dealer for reference in case the vehicle is stolen.

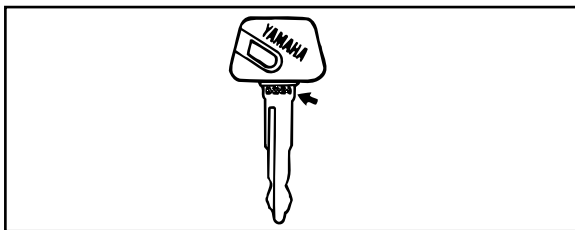

EAA61400

Key identification number

The key identification number is stamped on the key.

Record this number in the space provided and use it for reference when obtaining a new key.

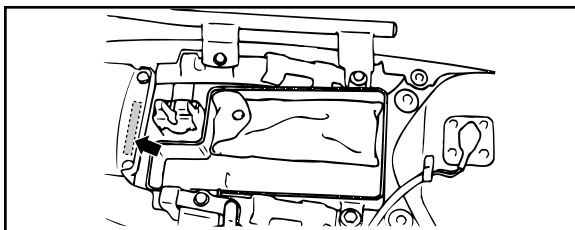

EAA60700

Frame serial number

The frame serial number is stamped into the the frame.

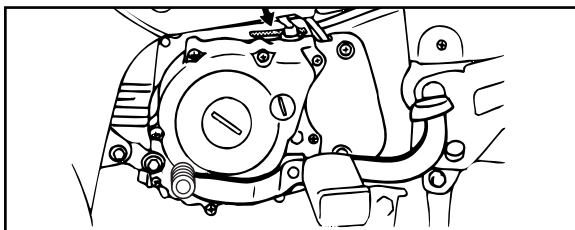

EAA70001



Engine serial number

The engine serial number is stamped into the crankcase.

CONTROL FUNCTIONS

Main switch

The main switch controls the ignition and lighting systems. Its operation is described below.

Position	Function	Key removal
ON 	Electrical circuits are switched on. The engine can be started.	Cannot be removed.
OFF 	All electrical circuits are switched off.	Can be removed.
LOCK 	The steering is locked and all electrical circuits are switched off.	Can be removed.

Indicator lights

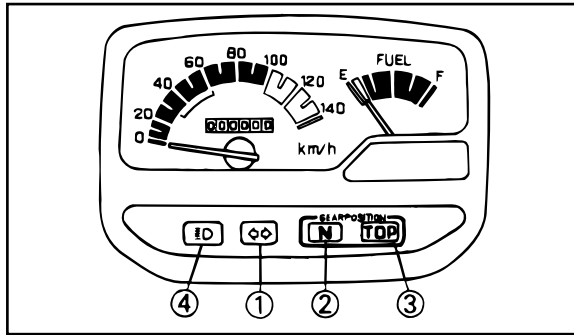

- ① Turn indicator light
- ② Neutral indicator light
- ③ Top gear indicator light
- ④ High beam indicator light

Description	Function
Turn indicator light “↔”:	Flashes when the turn switch is “ON”.
Neutral indicator light “N”:	Lights when the transmission is in neutral.
Top gear indicator light “TOP”:	Light when the transmission is in top (4th) gear.
High beam indicator light “≡▷”:	Lights when the headlight high beam is used.

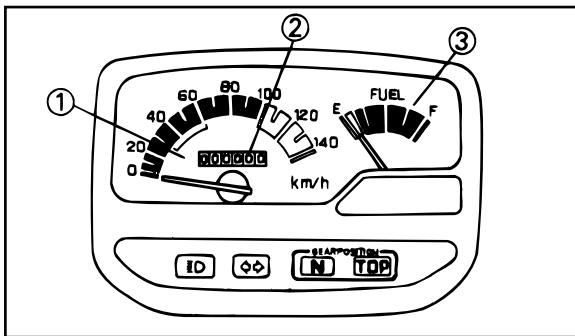

- ① Speedometer
- ② Odometer
- ③ Fuel gauge

Instrument panel

Description	Function
Speedometer	Shows riding speed.
Odometer	Shows accumulated mileage.
Fuel gauge	Shows the fuel level in the fuel tank.

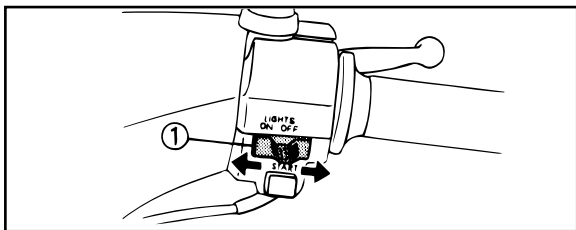

① Lights switch

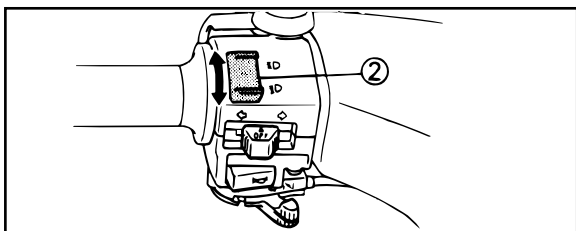

② Dimmer switch

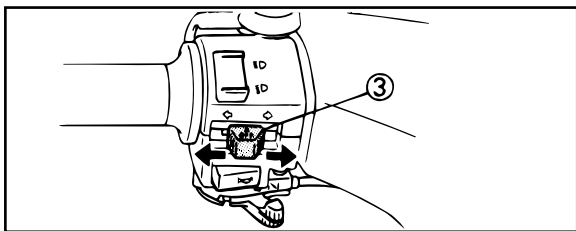

③ Turn signal switch

Handlebar switches

Lights switch

Position	Function
ON	Headlight, taillight and meter lights comes on when engine is running.
OFF	Headlight, taillight and meter lights does not come on.

Dimmer switch

Position	Function
☰ (HI)	Turns on the headlight high beam.
☷ (LO)	Turns on the headlight low beam.

Turn signal switch

Position	Function
←	Turns on the left flasher.
→	Turns on the right flasher.
△ OFF	Turns off the flasher. Push the switch in after it has returned to center position.

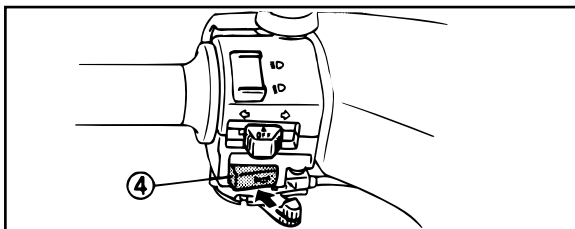

④ Horn switch

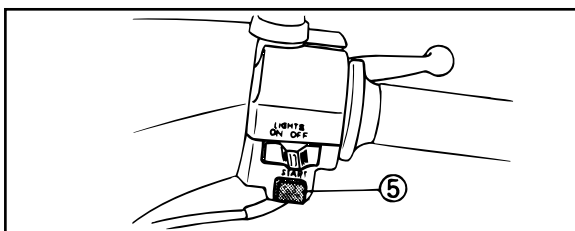

⑤ Start switch

Horn switch

Position	Function
 (HORN)	The horn sounds when pushing the switch.

Start switch

Position	Function
START 	The starter motor cranks the engine when pushing the switch.

EAB80001

Shift pedal

This motorcycle is equipped with a constant-mesh 4-speed transmission. The shift pedal is located on the left side of the engine.

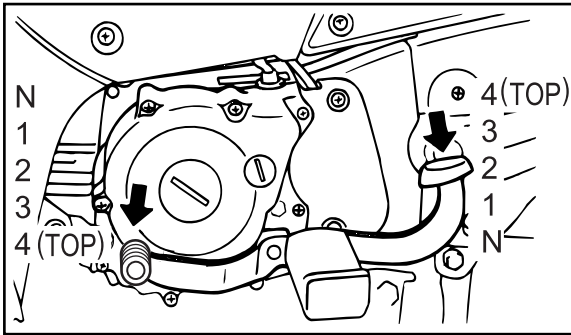

① Shift pedal

N. Neutral

EAB90001

Front brake lever

The front brake lever is located on the right handlebar. Pull it toward the handlebar to apply the front brake.

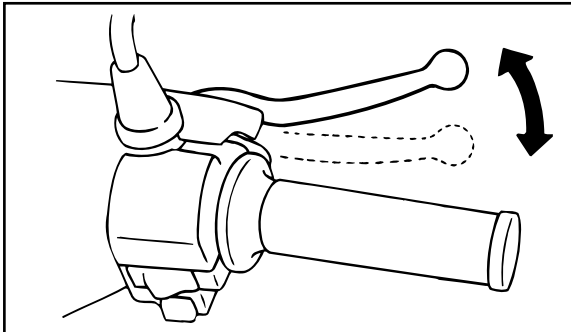

① Front brake lever

EAB90101

Rear brake pedal

The rear brake pedal is on the right side of the motorcycle. Press down on the brake pedal to apply the rear brake.

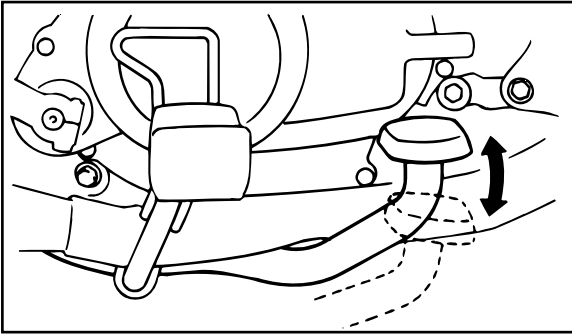

① Rear brake pedal

EAC01300*

Fuel tank cap

To add fuel, open the seat. Then remove the fuel tank cap by turning it counterclockwise.

(See page 20 to open the seat.)

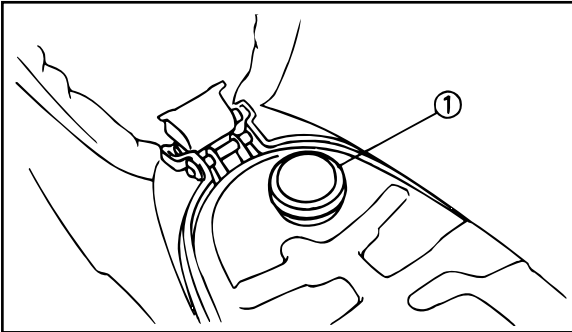

① Fuel tank cap

EAC20100

Starter lever |↖|

The starter lever is located on the left handlebar. Starting a cold engine requires a richer fuel mixture. In such a case, turn the starter lever to the left. After the engine is warm, turn the lever to its original position.

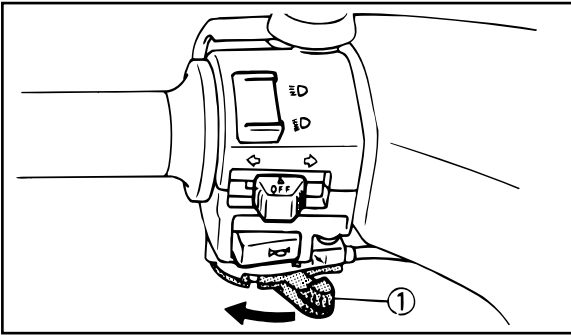

① Starter lever

EAC60700

Kick starter

Rotate the kick starter away from the engine. Push the starter down lightly with your foot until the gears engage, then kick smoothly and forcefully to start the engine.

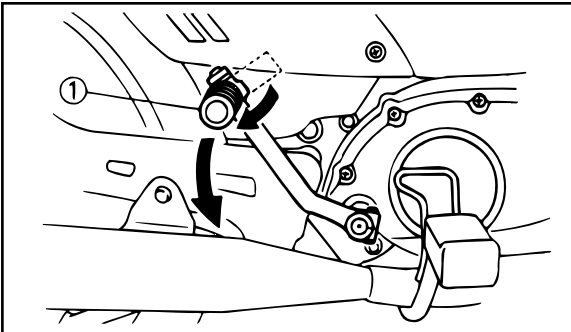

① Kick starter

Steering lock

The steering is locked when the main switch is turned to "LOCK". To lock the steering, turn the handlebars all the way to the left. With the key at "OFF", push it into the main switch and release it, turn it counterclockwise to "LOCK", and remove it. To release the lock, turn the key to "OFF".

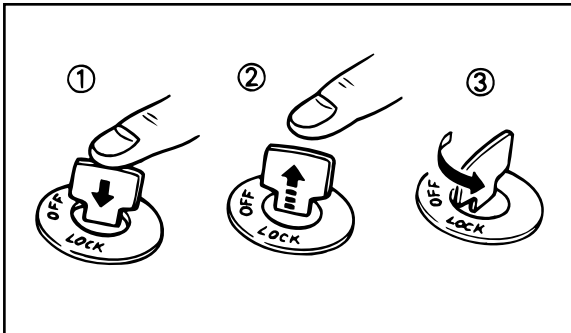
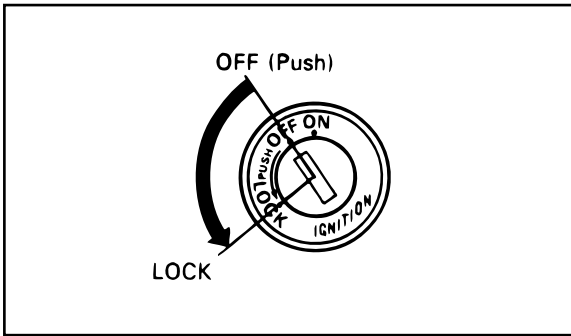

① Push

② Release

③ Turn

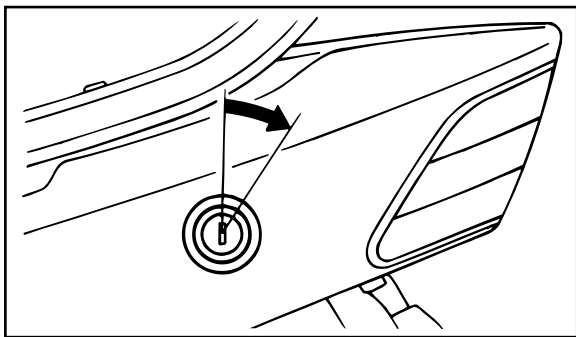

EAC42301

Seat

To open the seat:

1. Insert the key in the lock and turn it as shown.
2. Lift the end of the seat up to open.

To lock the seat:

1. Replace the seat in the original position.
2. Slightly push the end of the seat down to lock.

EUU01700

NOTE: _____

Make sure that the seat is securely fitted.

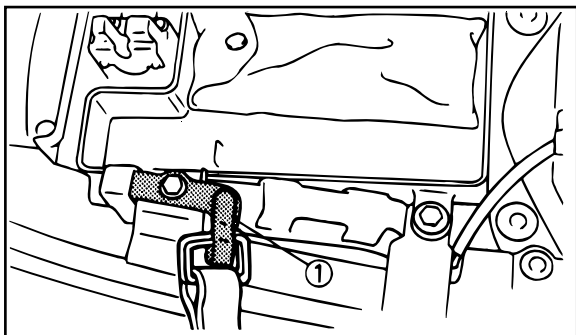

① Helmet holder

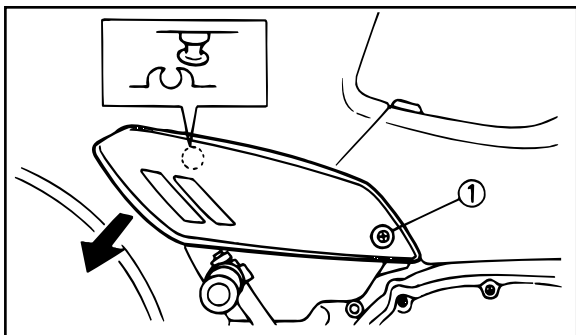

① Screw

EAC50001

Helmet holder

To open the helmet holder, insert the key in the lock and turn it as shown. To lock the helmet holder, replace the holder in its original position.

EUU72900

⚠WARNING

Never ride with a helmet in the helmet holder. The helmet may hit objects, causing loss of control and possibly an accident.

Side cover removal

Remove the screw. Then remove the side cover by pulling outward as shown.

PRE-OPERATION CHECKS

Before using this motorcycle, check the following points:

Item	Routine	Page
Fuel	<ul style="list-style-type: none">• Check fuel level/top up as required.	24
Engine oil	<ul style="list-style-type: none">• Check oil level/add oil as required.	25, 41~43
Front brake	<ul style="list-style-type: none">• Check operation, condition and free play. Adjust if necessary.• Check fluid level and fluid leakage. Fill with DOT3 or DOT4 brake fluid if necessary. (T105SE)	50~53
Rear brake	<ul style="list-style-type: none">• Check operation and pedal free play. Adjust if necessary.	54
Throttle grip/Housing	<ul style="list-style-type: none">• Check for smooth operation. Lubricate/Adjust if necessary.	—
Drive chain	<ul style="list-style-type: none">• Check chain slack and condition. Adjust if necessary.	56~59
Wheels/Tires	<ul style="list-style-type: none">• Check tire pressure, wear, damage and spoke tightness.	26~27
Control/Meter cable	<ul style="list-style-type: none">• Check for smooth operation. Lubricate if necessary.	—
Brake and shift pedal shafts	<ul style="list-style-type: none">• Check for smooth operation. Lubricate if necessary.	60
Brake lever pivots	<ul style="list-style-type: none">• Check for smooth operation. Lubricate if necessary.	60
Center and sidestand pivots	<ul style="list-style-type: none">• Check for smooth operation. Lubricate if necessary.	60
Fittings/fasteners	<ul style="list-style-type: none">• Check all chassis fittings and fasteners.• Tighten/Adjust, if necessary.	—
Lights and signals	<ul style="list-style-type: none">• Check for proper operation.	—
Switches	<ul style="list-style-type: none">• Check for proper operation.	—
Battery	<ul style="list-style-type: none">• Check fluid level, top-up with distilled water if necessary.	62~64

NOTE:

Pre-operation checks should be made each time the motorcycle is used. Such an inspection can be thoroughly accomplished in a very short time; and the added safety it assures is more than worth the time involved.

 WARNING

If any item in the Pre-Operation Check is not working properly, have it inspected and repaired before operating the motorcycle.

EAE80000

Fuel

Make sure there is sufficient fuel in the tank.

EUU61000

⚠ WARNING

Do not overfill the fuel tank. Avoid spilling fuel on the hot engine. Do not fill the fuel tank above the bottom of the filler tube as shown in the illustration or it may overflow when the fuel heats up later and expands.

EUU39302

CAUTION:

Always wipe off spilled fuel immediately with a dry and clean soft cloth. Fuel may deteriorate painted surfaces or plastic parts.

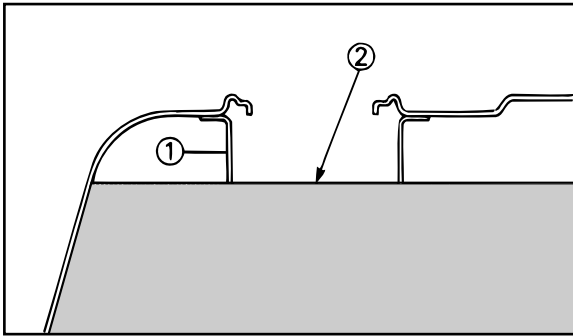

1. Filler tube

2. Fuel level

EAE80300

Recommended fuel:
Regular gasoline
Fuel tank capacity:
4.3 L

Engine oil

Make sure the engine oil is at the specified level. Fill with oil as necessary (see page 41 for details).

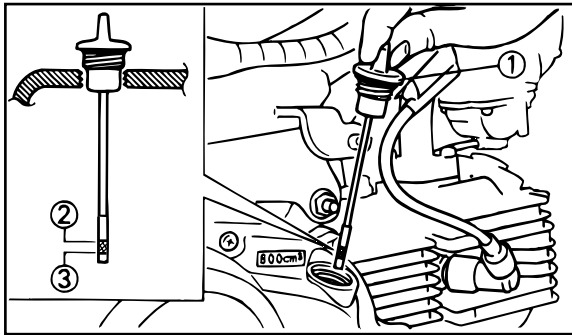

① Oil level gauge ② Upper level ③ Lower level

Recommended oil:

Yamalube 4 (20W40) or equivalent
SAE 20W40 type SE motor oil

Oil quantity:

Total amount:

1.0 L

Periodic oil change:

0.8 L

Cold tire pressure:	Front	Rear
Solo rider	175 kPa (1.75 kgf/cm ²)	200 kPa (2.0 kgf/cm ²)
With passenger	200 kPa (2.0 kgf/cm ²)	225 kPa (2.25 kgf/cm ²)

Tires

To ensure maximum performance, long service, and safe operation, note the following:

1. Tire air pressure

Always check and adjust the tire pressure before operating the motorcycle.

⚠WARNING

Tire inflation pressure should be checked and adjusted when the temperature of the tire equals the ambient air temperature. Tire inflation pressure must be adjusted according to total weight of cargo, rider, and passenger.

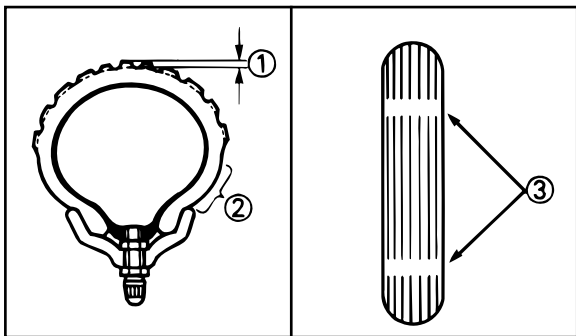

1. Tread depth 2. Side wall 3. Wear indicator

FRONT	Size
	2.25-17 33L

REAR	Size
	2.50-17 38L

Minimum tire tread depth (front and rear)	1.0 mm
--	--------

2. Tire inspection

Always check the tires before operating the motorcycle. If center tread depth reaches the limit as shown, if the tire has a nail or glass fragments in it, or if the side wall is cracked, contact a Yamaha dealer immediately and have the tire replaced.

⚠ WARNING

It is dangerous to ride with a worn-out tire. When a tire tread begins to show lines, have a Yamaha dealer replace the tire immediately. Brakes, tires, and related wheel parts replacement should be left to a Yamaha Service Technician.

EAF00000

OPERATION AND IMPORTANT RIDING POINTS

EAF18800*

Starting and warming up a cold engine

1. Turn the main switch to "ON".
2. Shift transmission into neutral.

EUU03000

NOTE: _____

When the transmission is in neutral, the neutral indicator light (green) should be on. If the light does not come on, ask a Yamaha dealer to inspect it.

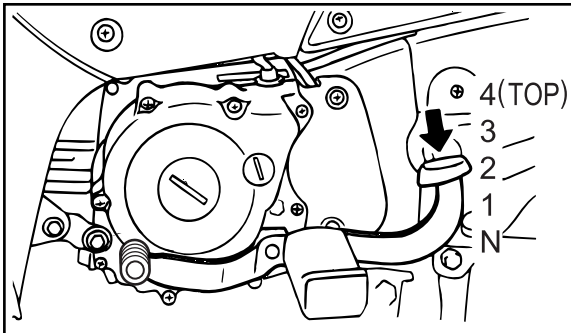
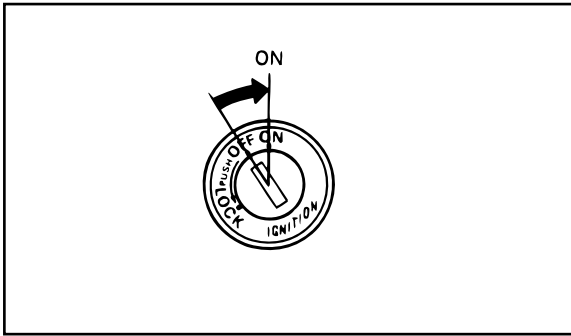

N. Neutral

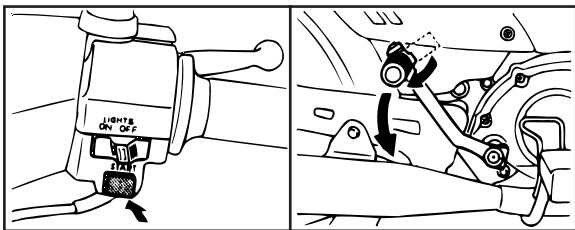
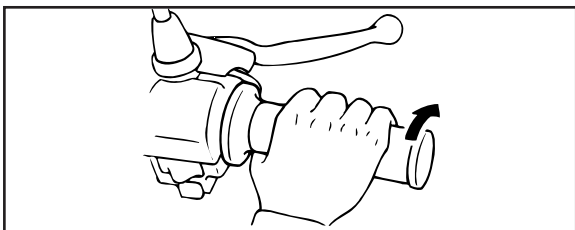
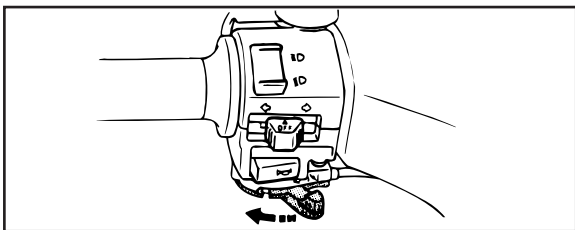

3. Fully open the starter lever “|””, and completely close the throttle grip.
4. Start the engine by pushing the starter switch or by kicking the kick starter.

EUU03401

NOTE: _____

If the engine fails to start, release the starter switch, wait a few seconds, then try again. Each attempt should be as short as possible to preserve the battery. Do not crank the engine more than 10 seconds on any one attempt. If the engine does not start with the starter motor, kick the kick starter to start the engine.

5. After starting the engine, move the starter lever to warming up position (about halfway).

EUU02600

NOTE: _____

For maximum engine life, always warm up the engine before starting off. Never accelerate hard with a cold engine!

6. After warming up the engine, turn off the starter completely.

EUU02700

NOTE: _____

The engine is warm when it responds normally to the throttle with the starter turned off.

EAF10802*

Starting a warm engine

The starter lever “|↘|” is not required when the engine is warm.

CAUTION: _____

Make sure the starter is turned off before starting a warm engine.

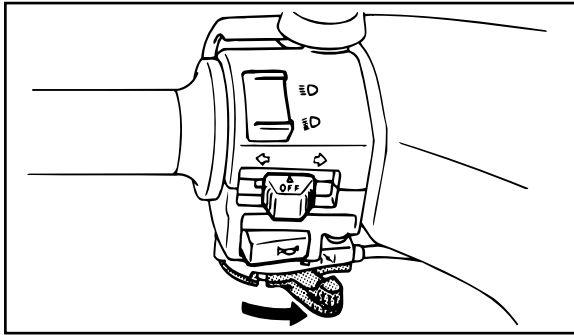

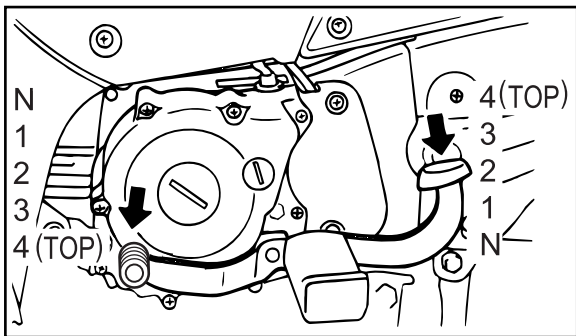

① Shift pedal

N. Neutral

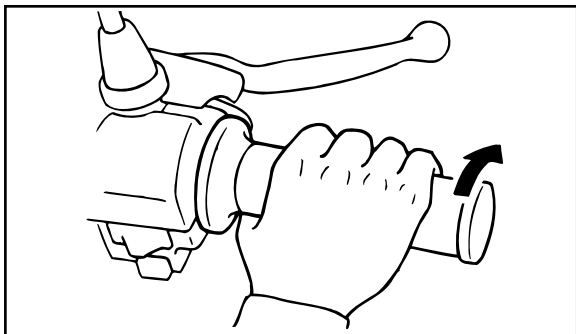

Shifting

The transmission lets you control the amount of power you have available at a given speed for starting, accelerating, climbing hills, etc. The use of the shift pedal is shown in the illustration.

To start out and accelerate

1. Close the throttle completely.

CAUTION:

Always close the throttle while shifting gears. Otherwise, damage to the engine and drive train can result.

2. Shift into FIRST gear.
3. Open the throttle gradually.

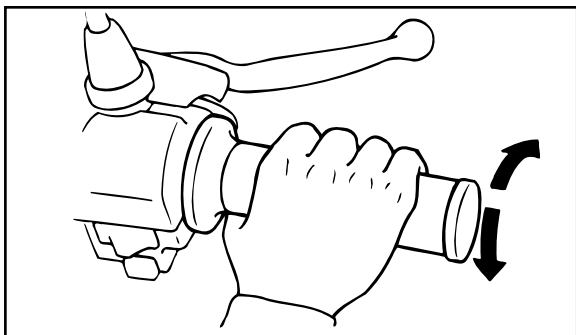
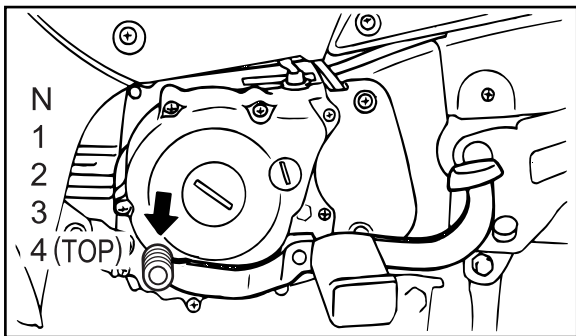

4. Once the motorcycle has reached a high enough speed to change gears, close the throttle.
5. Shift into SECOND gear.
6. Open the throttle gradually.
7. Follow the same procedure when shifting to the next higher gear.
8. The speed can be adjusted by opening and closing the throttle grip. Turning it toward you increases the speed, and turning it in the opposite direction decreases the speed.

Recommend shift point

Gear position	Recommend speed
1 st	0~20 km/h
2 nd	20~40 km/h
3 rd	30 km/h~
4 th (Top)	40 km/h~

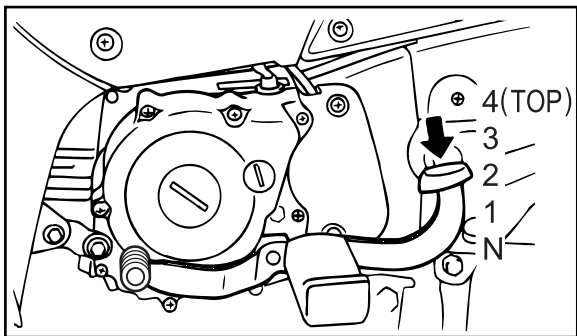

To decelerate

1. Close the throttle and apply both the front and the rear brakes at the same time to slow the motorcycle.
2. Downshift through the gears and when the motorcycle is almost completely stopped, shift into neutral.

Recommend shift point:

Gear position	Recommend speed
4th → 3rd	0~40 km/h
3rd → 2rd	0~30 km/h
2nd → 1st	0~15 km/h

Engine break-in

There is never a more important period in the life of your motorcycle than the period between zero and 1,000 km. Because the engine is brand new, prolonged full throttle operation, or any condition which might result in excessive heating of the engine must be avoided during this period.

EAF30800

1. 0~150 km:

Avoid prolonged operation above 1/3 throttle. Vary the speed of the motorcycle from time to time. Do not operate it at one set throttle position.

2. 150~500 km:

Avoid prolonged operation above 1/2 throttle. Rev the engine freely through the gears, but do not use full throttle at any time.

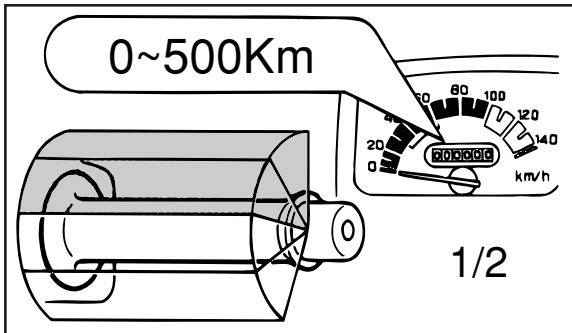
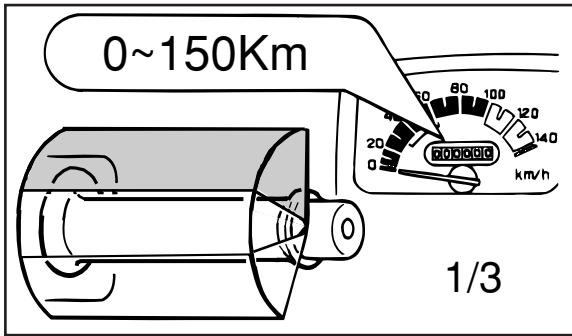

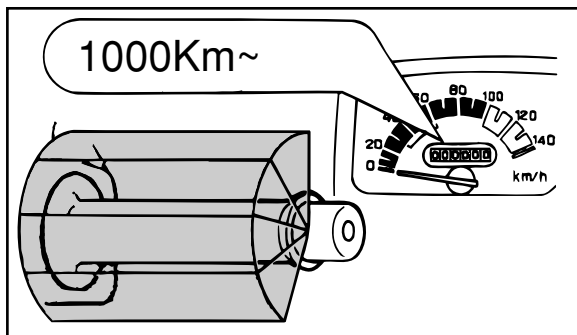
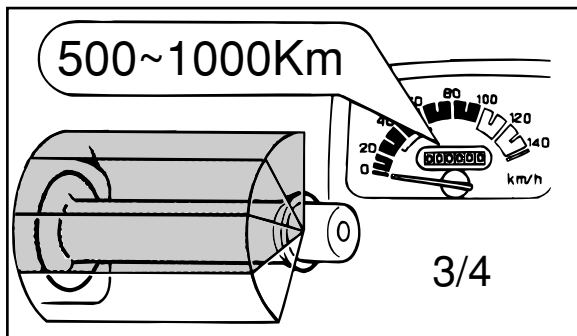

3. 500~1,000 km:
Avoid cruising speeds in excess of 3/4 throttle.

EUU40400

CAUTION: _____

After 1,000 km of operation, be sure to replace the engine oil.

4. 1,000 km and beyond:
Avoid prolonged full-throttle operation. Vary speed occasionally.

EUU32200

CAUTION: _____

If any engine trouble should occur during the break-in period, consult a Yamaha dealer immediately.

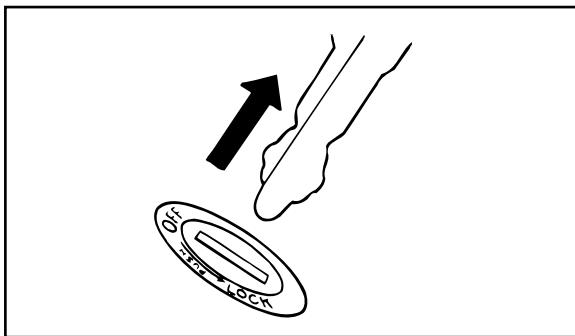

EAF40000

Parking

When parking the motorcycle, stop the engine and remove the ignition key.

EUU63000

⚠WARNING

The muffler and exhaust pipe are hot. Park the motorcycle in a place where pedestrians or children are not likely to touch the motorcycle. Do not park the motorcycle on a slope or soft ground; the motorcycle may overturn.

EAH00000

PERIODIC MAINTENANCE AND MINOR REPAIR

EAH00400

Periodic inspection, adjustment and lubrication will keep your motorcycle in the safest and most efficient condition possible. Safety is an obligation of the motorcycle owner. The maintenance and lubrication schedule chart should be considered strictly as a guide to general maintenance and lubrication intervals.

EUU63200

⚠ WARNING

If you are not familiar with motorcycle service, this work should be done by a Yamaha dealer.

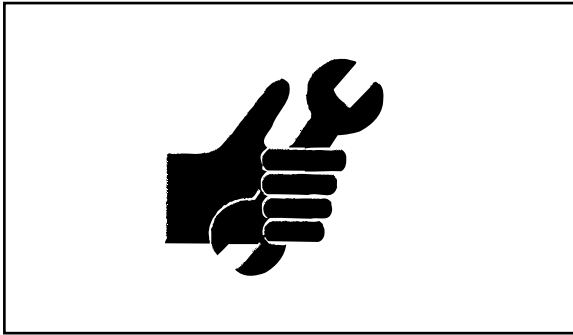

EAH10101*

Tool kit

The tools provided in the owner's tool kit are to assist you in the performance of periodic maintenance. However, some other tools such as a torque wrench are also necessary to perform the maintenance correctly.

EUU67100

⚠WARNING

Modifications to this motorcycle not approved by Yamaha may cause loss of performance, and render it unsafe for use. Consult a Yamaha dealer before attempting any changes.

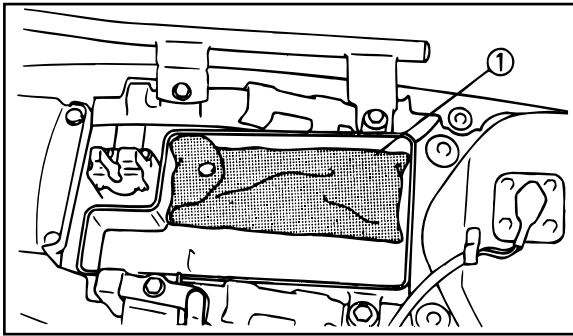

① Tool kit

PERIODIC MAINTENANCE/LUBRICATION

ITEM	REMARKS	INITIAL		EVERY	
		500 km	2,000 km	4,000 km	8,000 km
* Valve(s)	Check valve clearance. Adjust if necessary.	○	○	○	○
Spark plug	Check condition. Clean or replace if necessary.	○	○	○	○
Air filter	Clean. Replace if necessary.			○	○
* Carburetor	Check idle speed/stater operation. Adjust if necessary.	○	○	○	○
* Fuel line	Check fuel hose and vacuum pipe for cracks or damage. Replace if necessary.			○	○
Engine oil	Replace (Warm engine before draining).	○	○	EVERY 2,000 km	
* Engine oil filter	Check/clean/replace if necessary	○	○	○	○
* Front brake (T105SE)	Check operation, fluid level and fluid leakage. Replace brake pads if necessary.			○	○
* Front brake (T105E)	Check operation and adjust brake lever free play. Replace brake shoes if necessary.			○	○
* Rear brake	Check operation and adjust brake pedal free play. Replace brake shoes if necessary.			○	○
* Rear arm pivot	Check rear arm assembly for looseness. Correct if necessary. Moderately repack every. 16,000 km***				○
* Wheels	Check balance/damage/runout/spoke tightness. Replace if necessary.			○	○
* Wheel bearings	Check bearing assembly for looseness/damage. Replace if damaged.	○	○		○

ITEM	REMARKS	INITIAL		EVERY	
		500 km	2,000 km	4,000 km	8,000 km
* Steering bearing	Check bearing assembly for looseness. Correct if necessary. Moderately repack every 8,000 km. **			○	○
* Front forks	Check operation/oil leakage. Repair if necessary.			○	○
* Rear shock absorber	Check operation/oil leakage. Repair if necessary.			○	○
Drive chain	Check chain slack/alignment. Adjust if necessary. Clean and lube.	EVERY 500 km			
* Fittings/Fasteners	Check all chassis fitting and fasteners. Correct if necessary.	○	○	○	○
* Centerstand and sidestand	Check operation. Repair if necessary.	○	○	○	○
* Battery	Check specific gravity. Check that the breather pipe is working properly. Correct if necessary			○	○

*: It is recommended that these items be serviced by a Yamaha dealer.

** : Medium weight wheel bearing grease. (bearing type)

***: Lithium soap base grease. (bush type)

EAH48201*

Engine oil

1. Oil level measurement
 - a. Place the motorcycle on the center-stand. Warm up the engine for several minutes.

EUU03901

NOTE:

Be sure the motorcycle is positioned straight up when checking the oil level. A slight tilt toward the side can result in false readings.

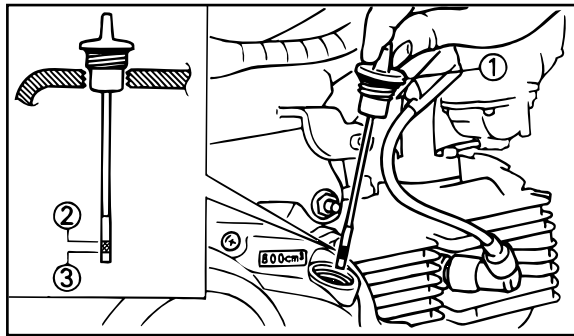

① Oil level gauge ② Upper level ③ Lower level

- b. With the engine stopped, wait a few minutes and then remove the oil level gauge.
 - c. Wipe the oil level gauge off with a clean rag and insert it in the filler hole without screwing it in.

- d. The oil level should be between the maximum and minimum marks. If the level is low, add sufficient oil to raise it to the proper level.

2. Engine oil replacement

- a. Warm up the engine for a few minutes.
- b. Stop the engine. Place an oil pan under the engine, and remove the oil level gauge.
- c. Remove the drain plug and drain the oil.

	Tightening torque
Drain plug	20 Nm (2.0 m•kg)

- d. Reinstall the drain plug (make sure it is tight.)

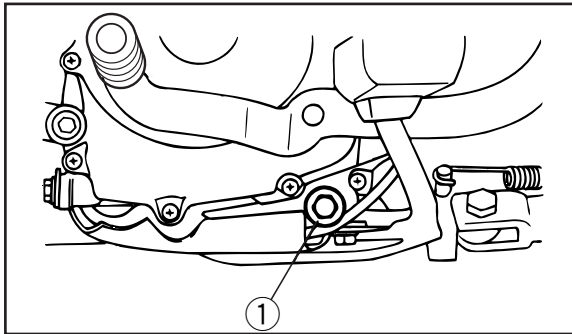

① Drain plug

Recommended oil:

See page 25

Oil quantity:

Total amount:

1.0 L

Periodic oil change:

0.8 L

e. Fill engine with oil through the oil level gauge hole.

EUU47700

CAUTION: _____

- **Do not put in any chemical additives or use oils with a grade of “CD (for Diesel engine)” or higher. Also, be sure not to use oils labeled “ENERGY CONSERVING II” or higher. Engine oil also lubricates the clutch and additives could cause clutch slippage.**
 - **Be sure no foreign material enters the crankcase.**
-

f. Start the engine and warm up for a few minutes. While warming up check for oil leakage. If oil leakage is found, stop the engine immediately, and ask a Yamaha dealer to check the cause.

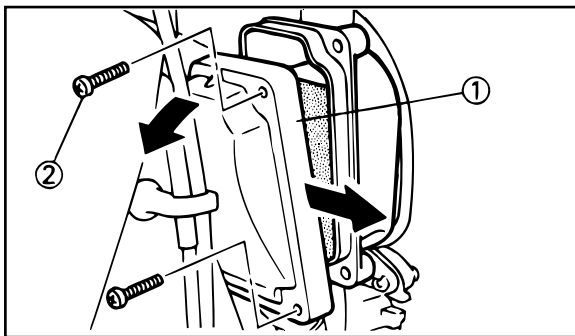

① Air filter case cover

② Screw (4 pcs)

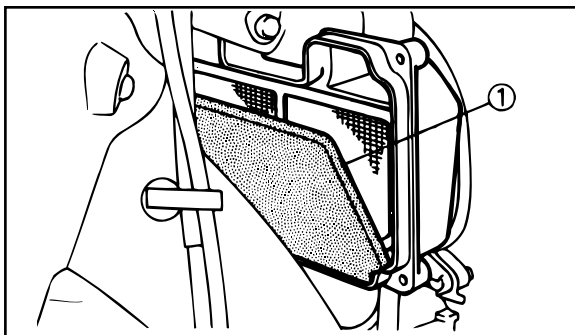

① Air filter element

Air filter

1. Remove the front panel and the legshield by removing the screws.
2. Remove the air filter case fitting screws and the filter case cover.
3. Remove the air filter element from its case, and clean it with solvent. After cleaning, remove the remaining solvent by squeezing the element.

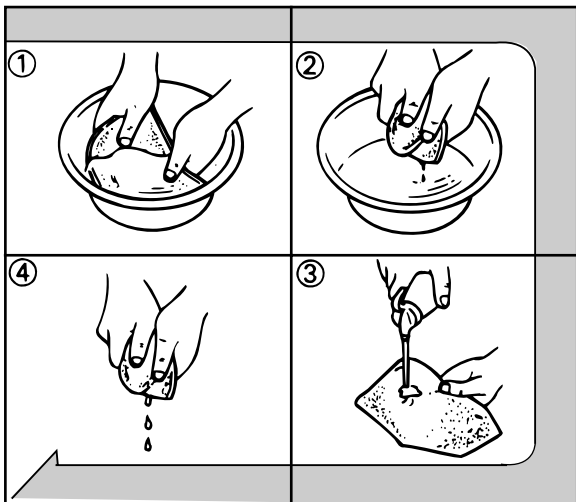

4. Apply recommended oil to the entire surface of the filter and squeeze out the excess oil. The element should be wet but not dripping.

Recommended oil:

Yamalube 2 (2 stroke engine oil) or
Yamalube 4 (20W40)

5. Install the element in its case.

CAUTION: _____

- If oil is not applied to the element, the engine damage may occur.
- Make sure the element is properly seated in the filter case.
- The engine should never be run without the air filter element installed; excessive piston and/or cylinder wear may result.

EAH92200

Throttle cable adjustment

EUU06400

NOTE: _____
Before adjusting the throttle cable free play, the engine idling speed should be adjusted.

The throttle cable should have a specified free play in the turning direction at the grip flange. If the free play is incorrect, ask a Yamaha dealer to make adjustment.

Free play:
3~7 mm

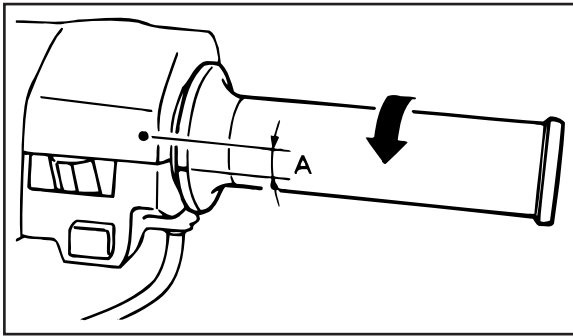

A. Free play: 3~7 mm

Carburetor adjustment

The carburetor is a vital part of the engine and requires very sophisticated adjustment. Most adjustments should be left to a Yamaha dealer who has the professional knowledge and experience to do so.

Standard idle speed:
1,400~1,600 r/min

Idle speed adjustment

1. Attach the tachometer.
2. Set the idle to the specified engine speed by adjusting the throttle stop screw; turn the screw in to increase engine speed, and out to decrease engine speed.

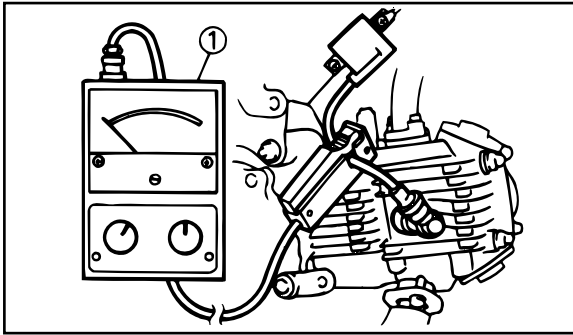

① Tachometer

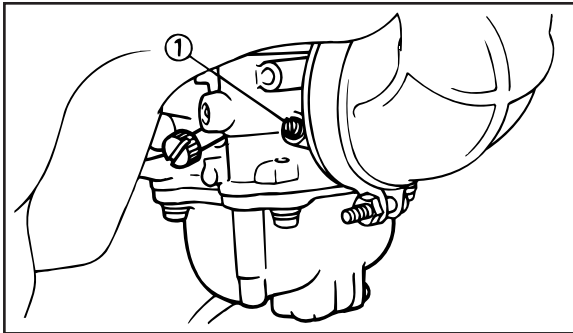

① Throttle stop screw

Standard spark plug:
C7HSA/NGK
U22FS-U/DENSO

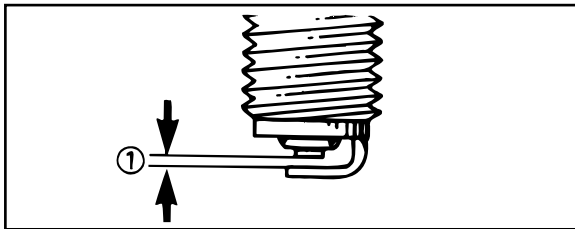
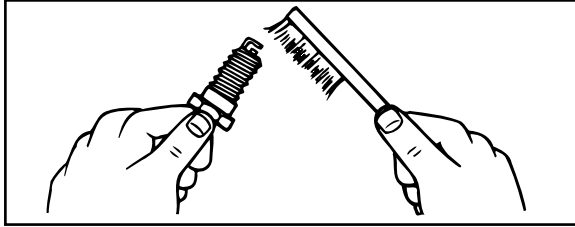

① Spark plug gap

Spark plug inspection

The spark plug is an important engine component and is easy to inspect. The condition of the spark plug can indicate the condition of the engine. The ideal color on the white insulator around the center electrode is a medium-to-light tan color for a motorcycle that is being ridden normally. Do not attempt to diagnose any problems yourself. Instead, take the motorcycle to a Yamaha dealer. You should periodically remove and inspect the spark plug because heat and deposits will cause the spark plug to slowly break down and erode. If electrode erosion becomes excessive, or if carbon and other deposits are excessive, you should replace the spark plug with the specified plug.

Spark plug gap:
0.6 ~ 0.7 mm

Spark plug torque:
12.5 Nm (1.25 m•kg)

Before installing the spark plug, measure the electrode gap with a wire thickness gauge; adjust the gap to specification as necessary.

When installing the plug, always clean the gasket surface and use a new gasket. Wipe off any grime from the threads and tighten the spark plug to the specified torque.

EUU03801

NOTE: _____

If a torque wrench is not available when you are installing a spark plug, a good estimate of the correct torque is 1/4 to 1/2 turn past finger tight. Have the spark plug torqued to the correct value as soon as possible with a torque wrench.

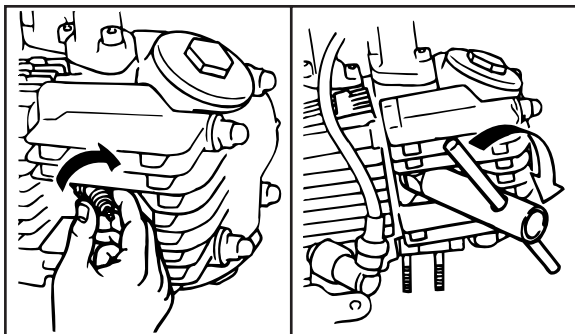

Front brake adjustment (T105E)

The front brake lever free play should be adjusted to 8~12 mm at the brake lever end. Adjustment is accomplished at the front brake hub. To adjust, turn the adjuster clockwise to reduce play or counterclockwise to increase play.

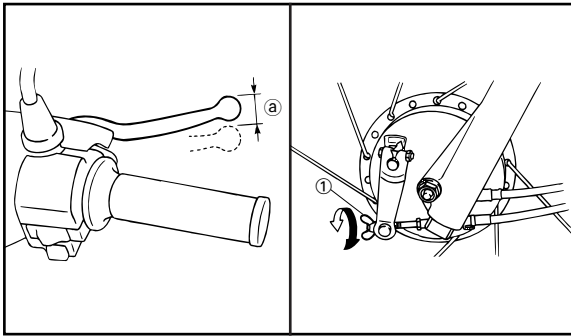

A. Free play: 8~12 mm

① Adjuster

Front brake adjustment (T105SE)

The free play at the end of the front brake lever should be 5~8 mm. To adjust, turn the adjuster ② until the free play (a) is within the specified limits. After adjusting, tighten the lock nut.

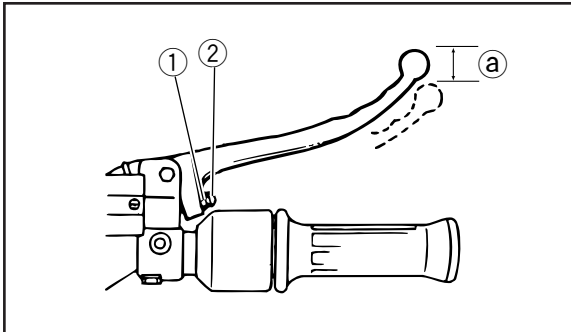

① Lock nut

② Adjuster

a. 5~8 mm

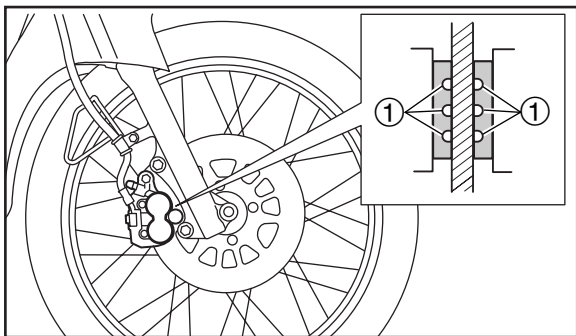

1. Brake pad wear indicator groove (x3)

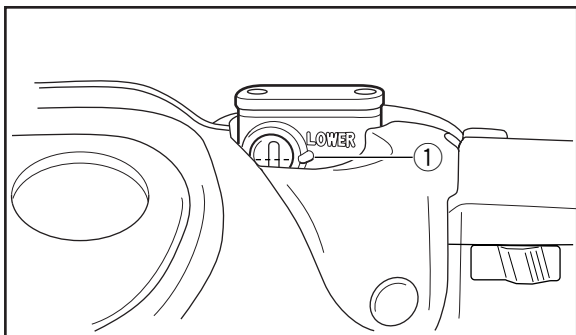

1. Minimum level mark

EAU01119*

Checking the front brake pads (T105SE)

Front brake pad is provided with wear indicator grooves. This indicator allow you to check the brake pad wear without disassembling the brake. To check the brake pad wear, check the wear indicator grooves. If the brake pad wear indicator grooves have almost disappeared, have a Yamaha dealer replace the brake pads as a set.

EAU00732

Checking the brake fluid level (T105SE)

Insufficient brake fluid may allow air to enter the brake system, possibly causing it to become ineffective.

Before riding, check that the brake fluid is above the minimum level mark and replenish if necessary. A low brake fluid level may indicate worn brake pads and/or brake system leakage. If the brake level is low, be sure to check the brake pads for wear and the brake system for leakage.

Observe these precautions:

- When checking the fluid level, make sure that the top of the master cylinder is level by turning the handlebars.
- Use only the recommended quality brake fluid, otherwise the rubber seals may deteriorate, causing leakage and poor braking performance.

Recommended brake fluid: DOT 4

NOTE: _____

If DOT 4 is not available, DOT 3 can be used.

- Refill with the same type of brake fluid. Mixing fluids may result in a harmful chemical reaction and lead to poor braking performance.

- Be careful that water does not enter the master cylinder when refilling. Water will significantly lower the boiling point of the fluid and may result in vapor lock.
- Brake fluid may deteriorate painted surfaces or plastic parts. Always clean up spilled fluid immediately.
- As the brake pads wear, it is normal for the brake fluid level to gradually go down. However, if the brake fluid level goes down suddenly, have a Yamaha dealer check the cause.

Changing the brake fluid (T105SE)

Have a Yamaha dealer change the brake fluid at the intervals specified in the periodic maintenance and lubrication chart. In addition, have the oil seals of the brake master cylinder and caliper as well as the brake hose replaced at the intervals listed below or whenever they are damaged or leaking.

- Oil seals: Replace every two years.
- Brake hose: Replace every four years.

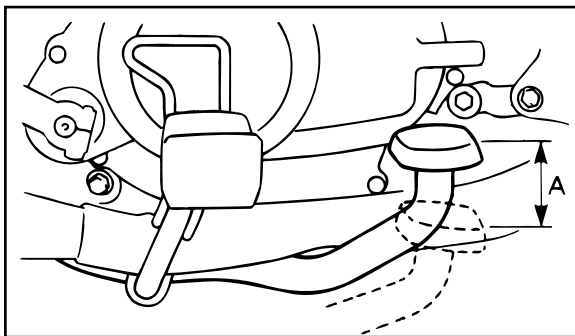

A. Free play: 20~30 mm

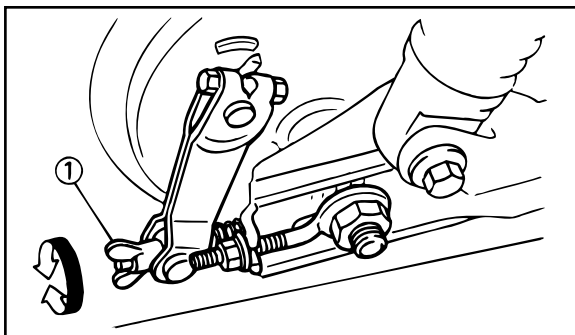

① Adjuster

Rear brake adjustment

The rear brake pedal free play should be adjusted to 20~30 mm at the brake pedal end. Turn the adjuster on the brake rod clockwise to reduce play or counterclockwise to increase play.

EUU69800

⚠WARNING

1. The rear brake pedal adjustment must be checked whenever the chain is adjusted or the rear wheel is removed and then reinstalled.
2. Check the operation of the brake light after adjusting the rear brake.

EAH83301

Brake light switch adjustment

The brake light switch is operated by movement of the brake pedal. To adjust, hold the main body of the switch so it does not rotate and turn the adjusting nut.

Proper adjustment is achieved when the brake light comes on just before the brake begins to take effect.

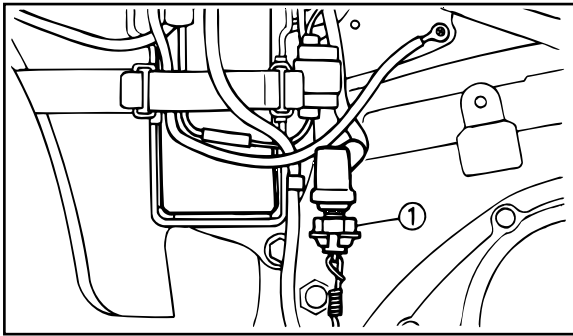

① Brake light switch

EAH81601

Checking the brake shoes

A wear indicator is provided on each brake. This indicator allows checking of shoe wear without disassembling the brake. Apply the brake and check the position of the indicator. If the indicator reaches to the wear limit line, ask a Yamaha dealer to replace the shoes.

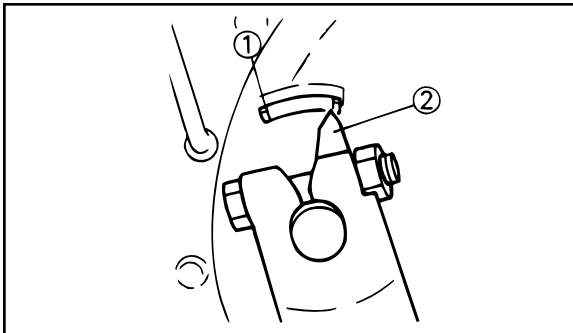

① Wear limit

② Indicator

EAI40001

Drive chain slack check

EUU04801

NOTE: _____

Spin the wheel several times and find the tightest position of the chain. Check and/or adjust the chain slack while it's in this tightest position.

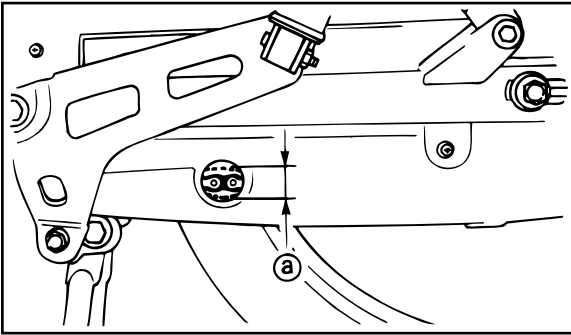

a. Drive chain slack: 20~30 mm

Inspect the drive chain when the motorcycle is on the centerstand. Check the slack at the position shown in the illustration. Normal slack is approximately 20~30 mm. If the slack exceeds 30 mm, adjust it.

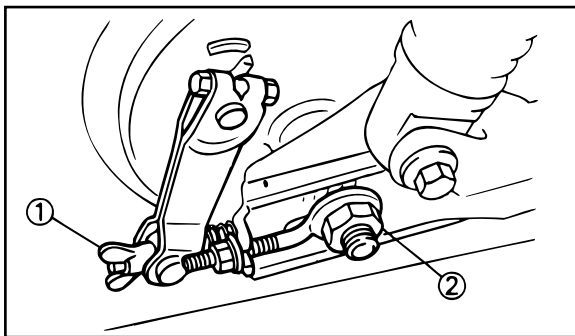

① Rear brake adjuster ② Axle nut

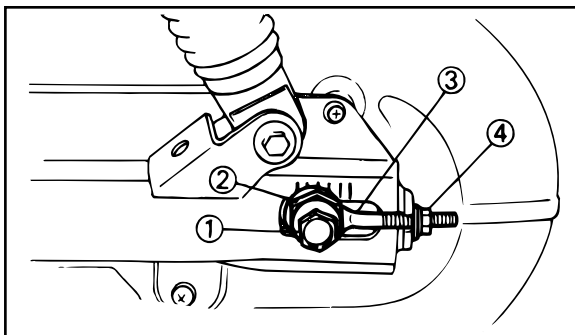

① Axle nut ② Sprocket shaft nut
③ Chain puller ④ Chain adjuster

Drive chain slack adjustment

1. Loosen the rear brake adjuster.
2. Loosen the axle nut.
3. Loosen the sprocket shaft nut and the axle nut.
4. To tighten the chain, turn the chain adjuster clockwise. To loosen the chain, turn the adjuster counterclockwise and push the wheel forward. Turn each adjuster exactly the same amount to maintain correct axle alignment. There are marks on each side of the swingarm and a match mark on each chain puller. Use these marks to align the rear wheel.

EUU33301

CAUTION:

Too little chain slack will overload the engine and other vital parts. Keep the slack within the specified limits.

Tightening torque:

Axle nut:

60 Nm (6.0 m•kg)

Sprocket shaft nut:

80 Nm (8.0 m•kg)

5. After adjusting, be sure to tighten the loosened parts.
Tighten the axle nut at specified torque.
6. Adjust the free play in the brake pedal.

Drive chain lubrication

The chain consists of many parts which work with each other. If the chain is not maintained properly, it will wear out quickly. Therefore, the chain must be serviced regularly. This service is especially necessary when riding in dusty areas.

1. Use any of the many brands of chain lubricant. First, remove all dirt and mud from the chain with a brush or cloth, then apply lubricant between both rows of side plates and on all center rollers. The chain should be lubricated every 500 km.
2. If the chain is too dirty or rusty, take the motorcycle for repair.

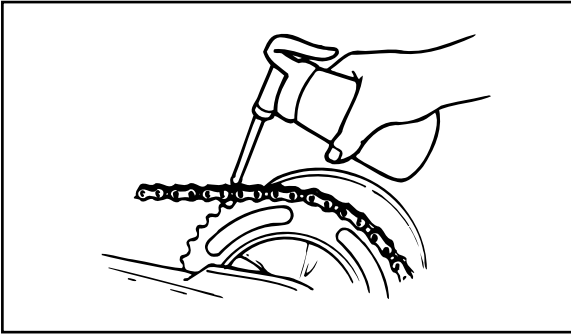

EAI30601

Brake lever and pedal

Lubricate the pivoting parts.

Recommended lubricant:

Yamalube 4 or SAE 20W40 motor oil

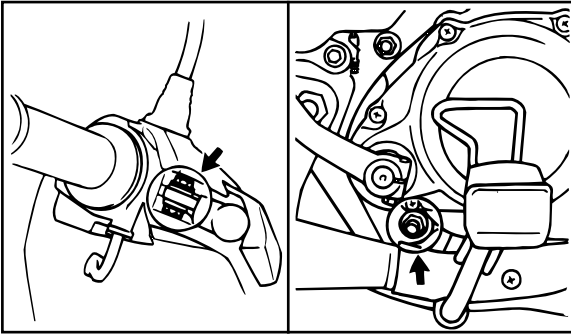

EAI30801

Center and sidestand

Lubricate the pivoting parts. Check to see that the center and sidestand move up and down smoothly.

Recommended lubricant:

Yamalube 4 or SAE 20W40 motor oil

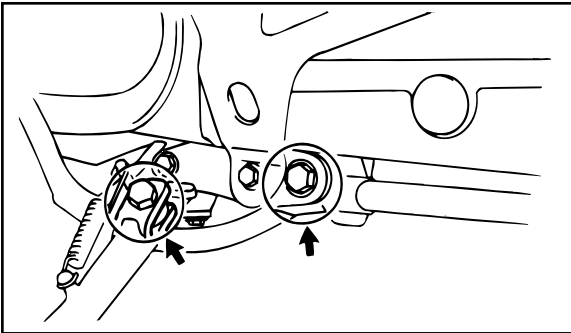

EAH20501

Front fork inspection

EUU65700

⚠WARNING

Securely support the motorcycle so there is no danger of it falling over.

Operation check

Place the motorcycle on a level place.

- a. Hold the motorcycle in an upright position and apply the front brake.
- b. Stroke the front forks up and down several times.

EUU42500

CAUTION:

If any damage or unsmooth movement is found with the front fork, consult a Yamaha dealer.

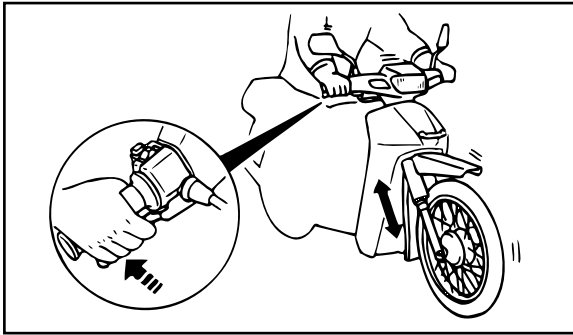

EAI70001*

Battery

Check the level of the battery electrolyte and make sure that the terminals are tight. Add distilled water if the electrolyte level is low.

NOTE: _____

The battery fluid should be checked at least once a month.

EUU33601

CAUTION: _____

When inspecting the battery, be sure the breather pipe is routed correctly.

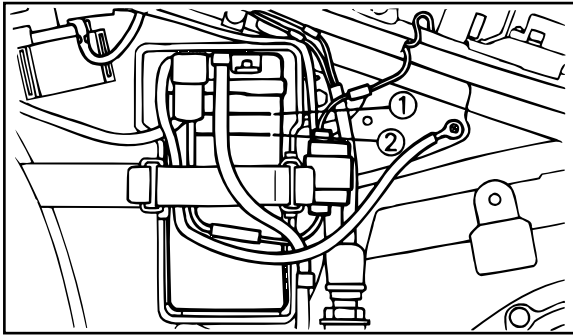

① Upper level

② Lower level

⚠ WARNING

Battery electrolyte is poisonous and dangerous, causing severe burns, etc. It contains sulfuric acid. Avoid contact with skin, eyes or clothing.

Antidote:

EXTERNAL: Flush with water.

INTERNAL: Drink large quantities of water or milk. Follow with milk of magnesia, beaten egg, or vegetable oil. Call a physician immediately.

Eyes: Flush with water for 15 minutes and get prompt medical attention. Batteries produce explosive gases. Keep sparks, flame, cigarettes etc., away. Ventilate when charging or using in an enclosed space. Always shield your eyes when working near batteries.

KEEP OUT OF REACH OF CHILDREN.

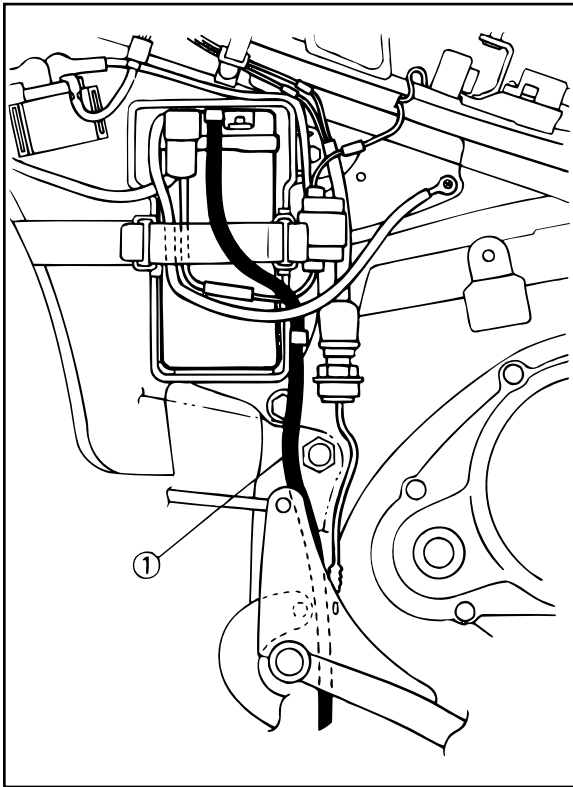

① Battery breather pipe

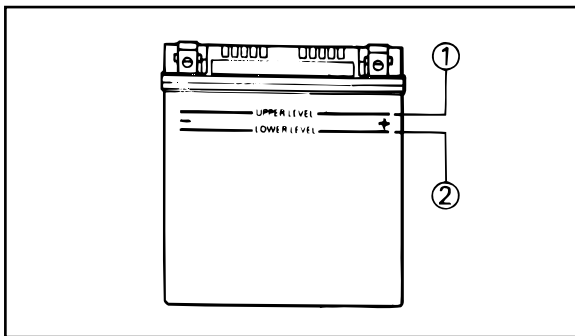

1. Maximum level "UPPER LEVEL"
2. Minimum level "LOWER LEVEL"

Replenishing the battery fluid

A poorly maintained battery will corrode and discharge quickly. The battery fluid should be checked at least once a month.

The level should be between the minimum and maximum marks. Use only distilled water if refilling is necessary.

EUU33800

CAUTION:

Normal tap water contains minerals which are harmful to a battery; therefore, refill only with distilled water.

EUU65901

⚠ WARNING

Take care not to spill battery fluid on the chain. Battery fluid may weaken the chain causing shorter chain life and possibly result in an accident.

Fuse replacement

1. The fuse case is located inside the right sidecover.
2. If a fuse is blown, turn off the ignition switch and the switch of the circuit in question. Install a new fuse of proper amperage. Turn on the switches and see if the electrical device operates. If the fuse immediately blows again, consult a Yamaha dealer.

CAUTION:

Do not use fuses of higher amperage rating than those recommended. Substitution of a fuse of improper rating can cause extensive electrical system damage and possibly a fire.

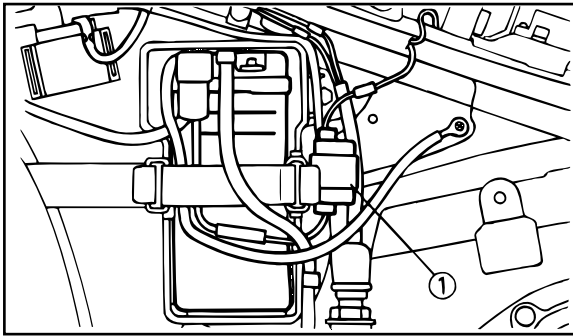

① Fuse case

Specified fuse: 7A

Troubleshooting

Although Yamaha motorcycles receive a rigid inspection before shipment from the factory, trouble may occur during operation. If your motorcycle requires any repair, bring it to a Yamaha dealer. The skilled technicians at a Yamaha dealership have the tools, experience, and know-how to properly service your motorcycle. Use only genuine Yamaha parts on your motorcycle. Imitation parts may look like Yamaha parts, but they are often inferior. Consequently, they have a shorter service life and can lead to expensive repair bills.

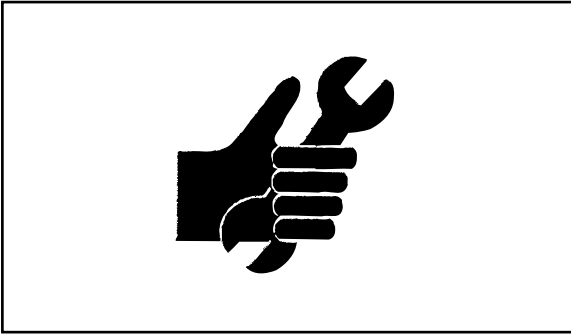

CLEANING AND STORAGE

EAK01302*

A. CLEANING

Frequent, thorough cleaning of your motorcycle will not only enhance its appearance but will improve its general performance and extend the useful life of many components.

1. Rinse the dirt and degreaser off with a garden hose.

EUU34602

CAUTION:

Excessive hose pressure may cause water seepage and deterioration of wheel bearings, front fork, brakes, transmission seals and electrical parts.

2. After cleaning the motorcycle, dry all surfaces with a chamois, clean towel, or soft absorbent cloth.

3. Dry the chain and lubricate it to prevent rust.
4. Automotive-type wax may be applied to all painted and chrome-plated surfaces. When finished, start the engine and let it idle for several minutes.

EAK00700

B. STORAGE

Long term storage (60 days or more) of your motorcycle will require some preventive procedures to guard against deterioration. After thoroughly cleaning the motorcycle, prepare for storage as follows:

1. Drain the fuel tank, fuel lines, and carburetor float bowl(s).
2. Remove the empty fuel tank, pour a cup of SAE 10W30 or 20W40 motor oil in the tank, shake the tank to coat the inner surfaces thoroughly and drain off the excess oil. Reinstall the tank.

3. Remove the drive chain. Thoroughly clean the chain with solvent and lubricate it. Reinstall the chain or store it in a plastic bag (tied to frame for safe-keeping).
4. Lubricate all control cables.
5. Block up the frame to raise both wheels off the ground.
6. Tie a plastic bag over the exhaust pipe outlet to prevent moisture from entering.
7. If storing in a humid or salt-air atmosphere, coat all exposed metal surfaces with a light film of oil. Do not apply oil to any rubber parts or the seat cover.
8. Remove the battery and charge it. Store it in a dry place and recharge it once a month. Do not store the battery in an excessively warm or cold place (less than 0°C (32°F) or more than 30°C (86°F)).

NOTE: _____
Make any necessary repairs before storing the motorcycle.

SPECIFICATIONS

Model	T105E/T105SE
Dimensions: Overall length Overall width Overall height Seat height Wheelbase Minimum ground clearance	1,870 mm 655 mm 1,050 mm 755 mm 1,190 mm 130 mm
Basic weight: With oil and full fuel tank	96 kg (T105E) 101 kg (T105SE)
Minimum turning radius:	1,800 mm
Engine: Type Cylinder arrangement Displacement Bore × stroke Compression ratio Starting system Lubrication system:	Air cooled 4 stroke, SOHC Forward inclined single cylinder 101.8 cm ³ 49.0 × 54.0 mm 9.0 : 1 Electric and kick starter Wet sump

Model	T105E/T105SE
Engine oil (4-cycle): Type Capacity Periodic oil change Total amount	Yamalibe 4 (20W40) or equivalent SAE 20W40 type SE motor oil 0.8 L 1.0 L
Air filter:	Wet type element
Fuel: Type Tank capacity	Regular gasoline 4.3 L
Carburetor: Type/manufacturer	VM16SH/MIKUNI

Model	T105E/T105SE
Spark plug: Type/manufacturer Gap	C7HSA/NGK, U22FS-U/DENSO 0.6~0.7 mm
Clutch type:	Wet, centrifugal automatic
Transmission: Primary reduction system Primary reduction ratio Secondary reduction system Secondary reduction ratio Transmission type Operation Gear ratio: 1st 2nd 3rd 4th	Spur gear 67/18 (3.722) Chain drive 37/15 (2.467) Constant mesh 4 speed Left foot operation 38/12 (3.167) 33/17 (1.941) 29/21 (1.381) 23/21 (1.095)

Model	T105E/T105SE
Chassis: Frame type Caster angle Trail	Steel Tube underbone 27° 78 mm
Tire: Type Size – Front Rear	With tube 2.25-17 33L 2.50-17 38L
Brake: Front brake type Operation Rear brake type Operation	Drum brake (T105E) Disk brake (T105SE) Right hand operation Drum brake Right foot operation
Suspension: Front Rear	Telescopic fork Swing arm
Shock absorber: Front Rear	Coil spring/oil damper Coil spring/oil damper

Model	T105E/T105SE
Wheel travel: Front Rear	90 mm 65 mm
Electrical: Ignition system Generator system Battery type/capacity	C.D.I Flywheel magneto 12V5AH
Headlight type:	Krypton bulb
Bulb wattage/quantity: Headlight Tail/brake light Flasher light Meter light	12V30W/30W × 1 12V/5W/21W × 1 12V10W × 4 12V1.7W × 1
Indicator light wattage/quantity: "NEUTRAL" "HIGH BEAM" "TURN" "TOP"	12V3.4W × 1 12V3.4W × 1 12V3.4W × 1 12V3.4W × 1

