

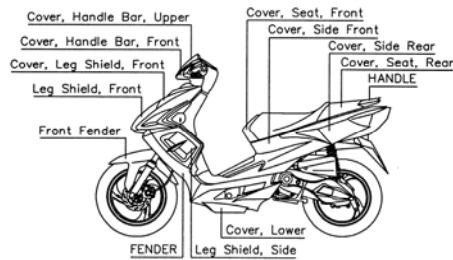

**SPARE PARTS**  
**Model : BM1**

# BM1 TABLE OF COLORED PART FOR FRANCE (SIMA)



**TABLE OF COLORED PART**

ITEM NO.	CODE	A	B	
	Basic Color	Electroplate Blue/ Silver White	Ferrari's Red/ Silver White	
	Description	EU / SW Blu 702 / Sil 601	FR / SW Red 701 / Sil 601	
23	Cover, Seat, Front	452051EU	452051FR	
	Cover, Seat, Rear.,	452057SWR4	452057SWR5	
	Cover, Seat, Rear	452057SW	452057SW	
	Emblem, Seat, Rear, Cover, LH.	459555EU	459555FR	
	Emblem, Seat, Rear, Cover, RH.	459564EU	459564FR	
24	Cover, Side Front, LH., With Emblem	453051EUL6	453051FRL6	
	Cover, Side Front, LH.	453051EU	453051FR	
	"SPORTS TGB" Emblem, LH.	459552	459552	
	Cover, Side Front, RH.	453052EUR6	453052FRR6	
	Cover, Side Front, RH., With Emblem	453052EU	453052FR	
	"SPORTS TGB" Emblem, RH.	459561	459561	
	Cover, Side Rear, LH., With Emblem	453053SWL7	453053SWL8	
	Cover, Side Rear, LH.	453053SW	453053SW	
	Emblem, Side Rear Cover, LH.(LOWER)	459554	459554	
	"BULLET" Emblem, LH.	459592EU	459592FR	
	Cover, Side Rear, RH., With Emblem	453054SWR7	453054SWR8	
	Cover, Side Rear, RH.	453054SW	453054SW	
	Emblem, Side Rear Cover, RH.(LOWER)	459563	459563	
	"BULLET" Emblem, RH.	459593EU	459593FR	
HANDLE	453056EU	453056FR		
25	Cover, Leg Shield, Front., With Emblem	454025PAF1	454025PAF1	
	Cover, Leg Shield, Front	454025PA	454025PA	
	"TGB" Emblem	459102	459102	
25	Leg Shield, Front., With Emblem	454026SWF3	454026SWF4	
	Leg Shield, Front	454026SW	454026SW	
	"BULLET" Emblem, LH.	459588EU	459588FR	
	"BULLET" Emblem, RH.	459589EU	459589FR	
26	FENDER, INNER	455030EU	455030FR	
26	Leg shield, Side, LH., With Emblem	455031EUL1	455031FRL1	
	Leg shield, Side, LH.	455031EU	455031FR	
	Emblem, Leg shield Side, LH.(Upper)	459549	459549	
	Emblem, Leg shield Side, LH.(Lower)	459550	459550	
26	Leg shield, Side, RH., With Emblem	455032EUR1	455032FRR1	
	Leg shield, Side, RH.	455032EU	455032FR	
	Emblem, Leg shield Side, RH.(Upper)	459558	459558	
	Emblem, Leg shield Side, RH.(Lower)	459559	459559	
26	Cover, Lower, LH., With Emblem	455046EUL7	455046FRL7	
	Cover, Lower, LH.	455046EU	455046FR	
	Emblem, Lower Cover, LH.	459551	459551	
26	Cover, Lower, RH., With Emblem	455047EUR7	455047FRR7	
	Cover, Lower, RH.	455047EU	455047FR	
	Emblem, Lower Cover, RH.	459560	459560	
27	Front Fork., With Emblem	412704E	412704E	
	"TGB" Emblem	459548	459548	
28	Front Fender., With Emblem	456010EUF4	456010FRF4	
	Front Fender	456010EU	456010FR	
	"SPORTS" Emblem, LH.	459590	459590	
	"SPORTS" Emblem, RH.	459591	459591	
31	Cover, Handle Bar, Upper	457109PA	457109PA	
	Cover, Handle Bar, Front	457127EU	457127FR	

# SUMMARY

## 1. HOW TO READ PARTS LIST :

1.1 AT FIRST TO JUDGE IN WHICH GROUP YOUR PART BELONG TO, FIND OUT GROUP NUMBER IN THE CONTENTS, NO.1-NO.11 ARE ENGINE PARTS, NO.12-NO.15 ARE ELECTRIC PARTS, NO.16-NO.37 ARE FRAME PARTS.

1.2 ACCORDING TO GROUP NUMBER FIND OUT THE DRAWING ON THAT UPPER SIDE PAGE.

1.3 FROM THE ITEM OF THE PART ON THE DRAWING, FIND THE PART NO., DESCRIPTION,REQUIRED QUANTITY.

1.4 USE THIS PART NO. DESCRIPTION AND QUANTITY TO ORDER.

## 2. COLOR CODE AND EMBLEM CODE:

2.1 COLOR CODE ATTACH TO PART NO. MUST BE TWO ALPHABETS, USE AT DIFFERENT COLOR PART ONLY.

2.2 EMBLEM CODE ATTACH TO COLOR CODE, MUST BE ONE ALPHABET AND ONE ARABIC NUMBER OR TWO ALPHABET, USE AT DIFFERENT COLOR EMBLEM ONLY. ANY EMBLEM WITHOUT DIFFERENT COLOR DON'T NECESSARY EMBLEM CODE.

2.3 WHEN YOU ORDER PARTS THAT HAVE DIFFERENT COLOR,PLEASE PICK UP THE RIGHT PART OR EMBLEM FROM " TABLE OF COLORED PARTS " (PAGE I).

## 3. AMEND. CODE : INDICATES THE LAST 6 NUMBERS OF FRAME NUMBER TO DISTINGUISH THE SCOOTER BEEN MODIFIED. EXAMPLE :

" ← 518034 " MEANS SCOOTERS BEFORE " □□□□□□□□□□518034 " .

" 518035 → " MEANS SCOOTERS AFTER " □□□□□□□□□□518035 " .

4. IF ANY MODIFICATION AFTER PUBLISHING,WE'LL SEND YOU THE AMENDMENT, PLEASE CORRECT YOUR PARTS LIST RIGHT AWAY.

**1. CYLINDER AND CRANK CASE COVER**

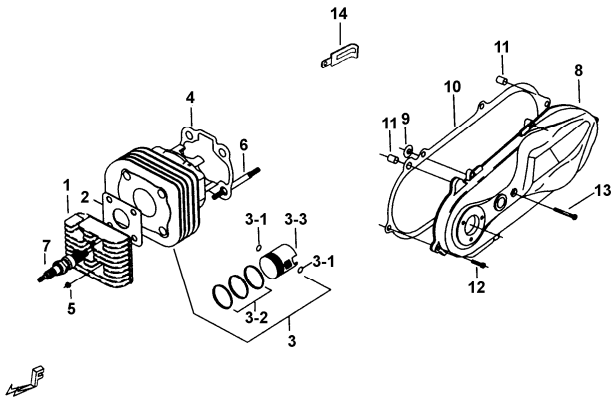

**2. CRANK CASE**

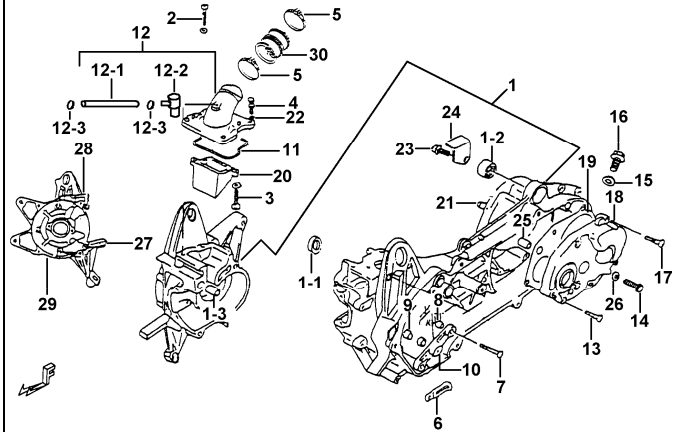

**3. CRANK SHAFT**

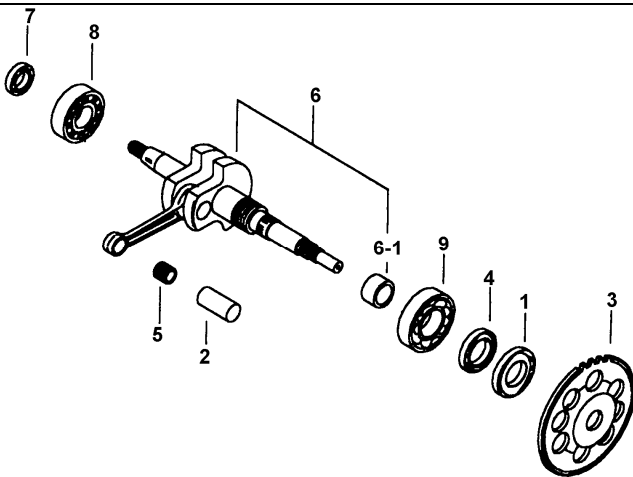

**4. CARBURETOR**

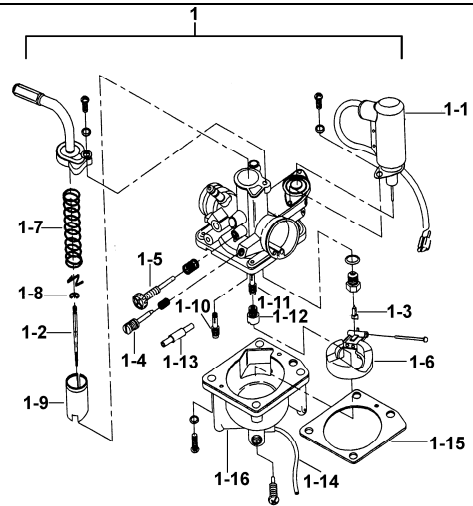

**5. OIL PUMP**

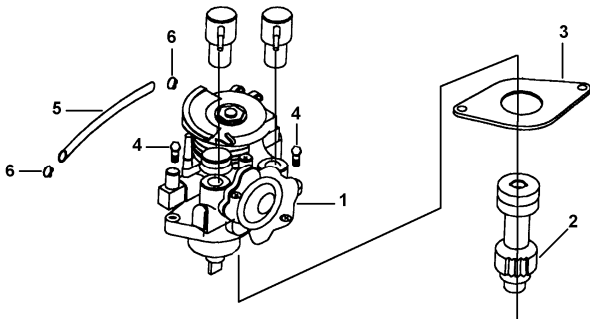

**6. CONTINUOUS VARIABLE TRANSMISSION**

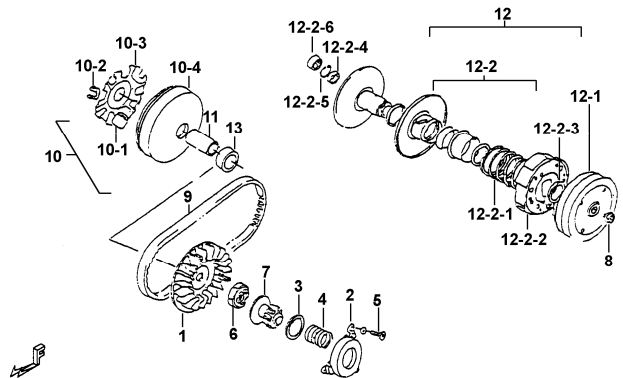

**7. MUFFLER**

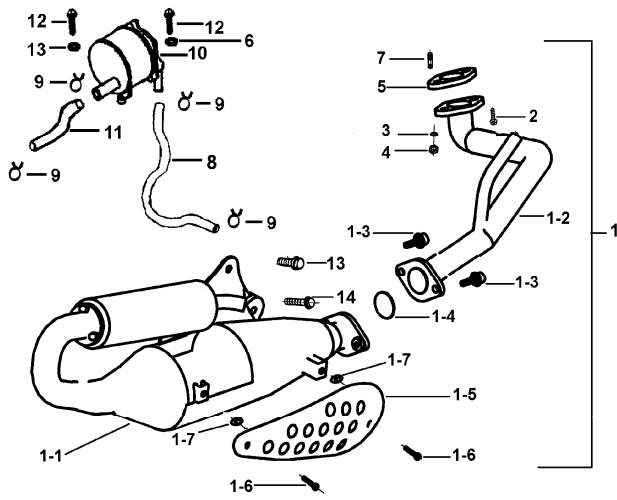

**8. COOLING FAN**

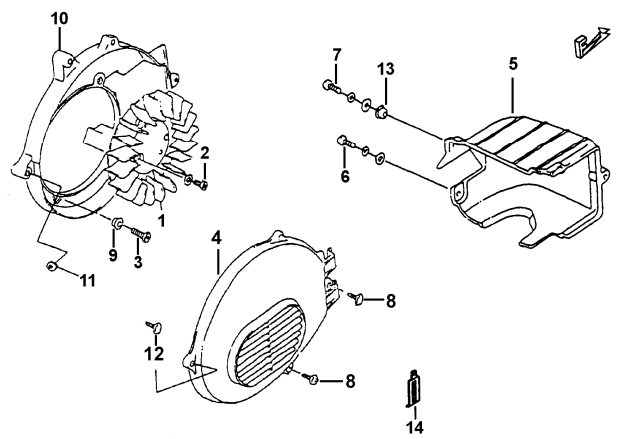

**9. AIR CLEANER**

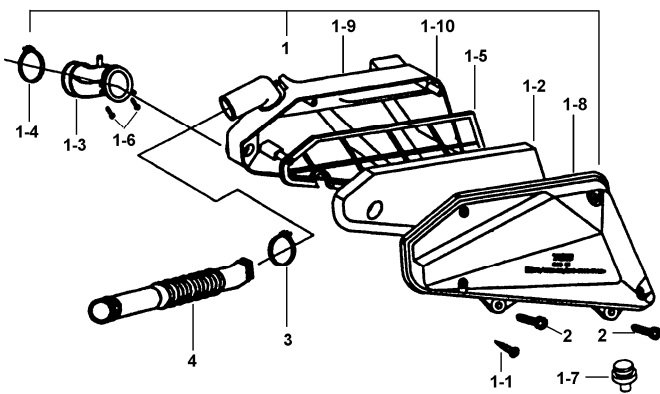

**10. REDUCING GEAR**

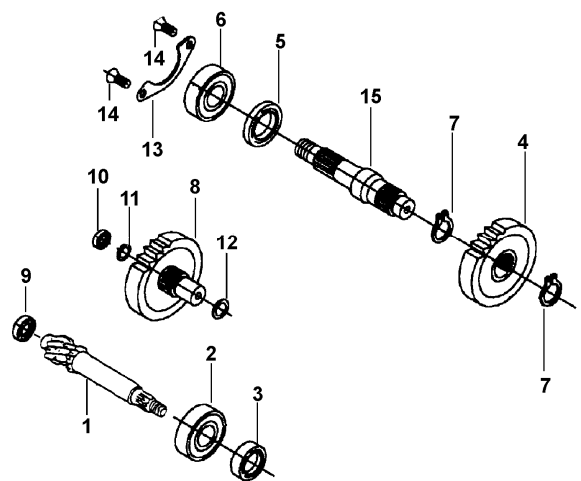

**11. KICK STARTER**

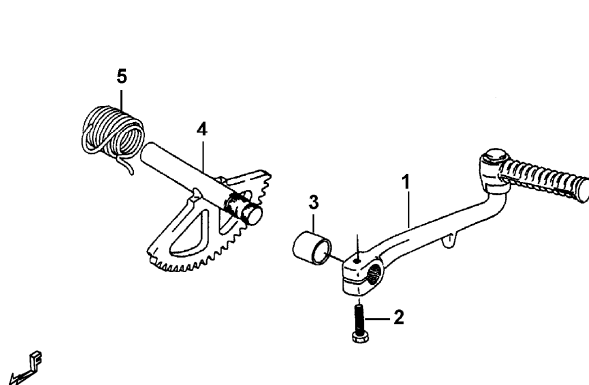

**12. STARTING MOTOR**

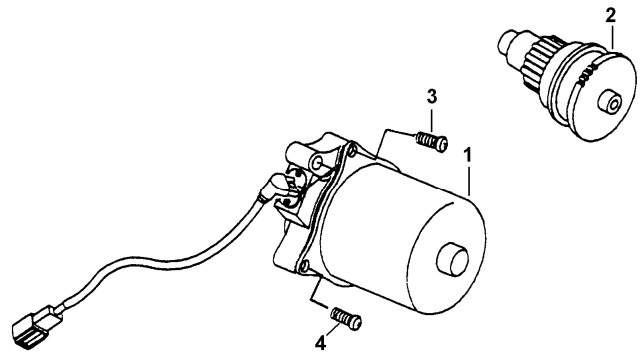

**13. FLYWHEEL MAGNETO AND IGNITION COIL**

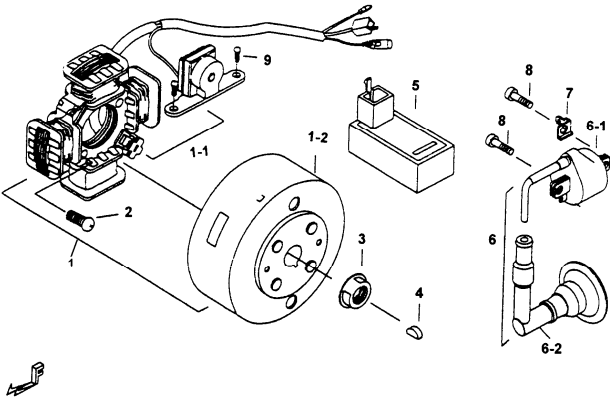

**14. BATTERY, HORN, RELAY, RECTIFIER**

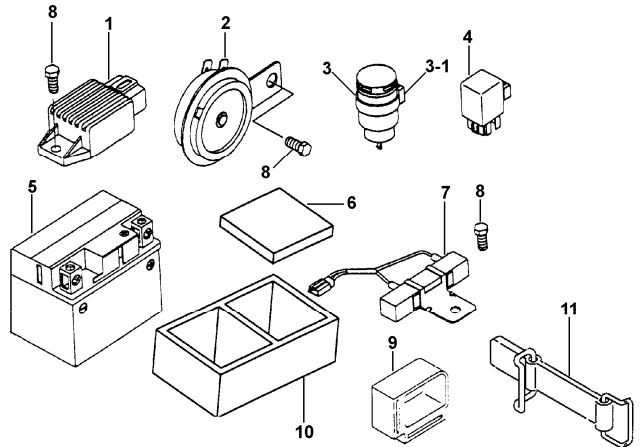

**15. WIRING HARNESS AND LOCK SET**

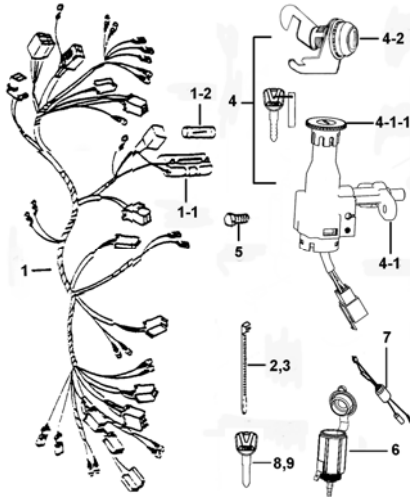

**16. SPEEDOMETER**

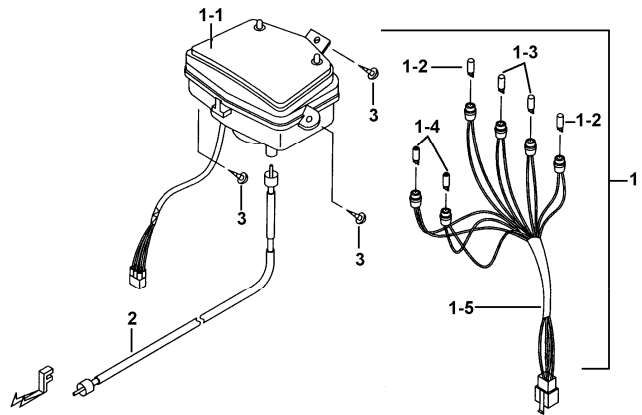

**17. HEAD LAMP AND FRONT TURN SIGNAL LAMP**

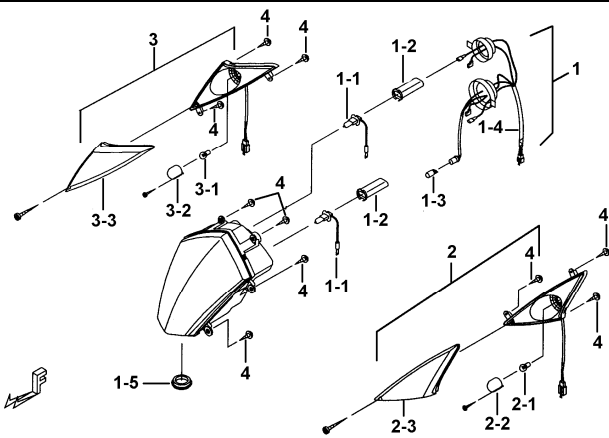

**18. REAR LIGHT CLUSTER**

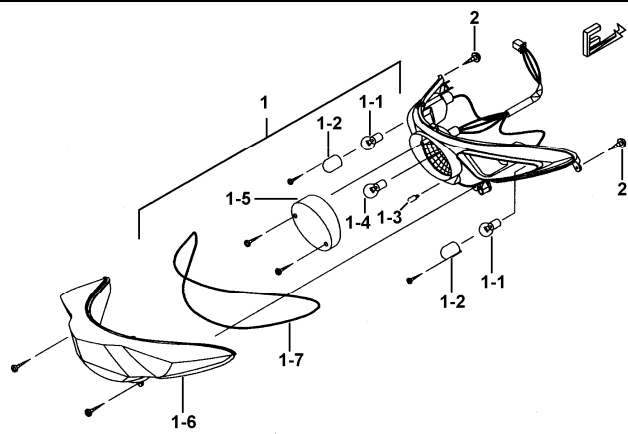

19 . FRAME

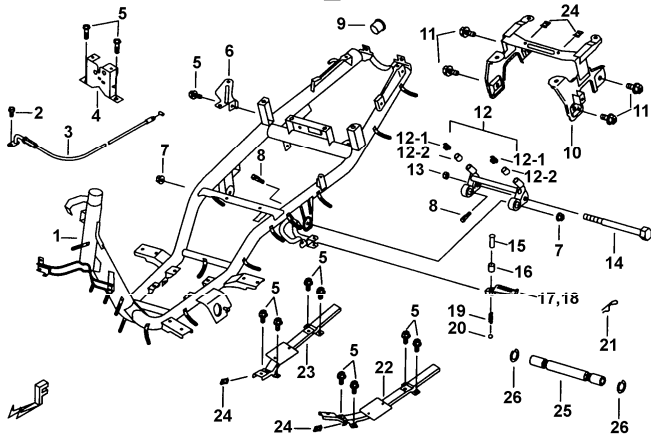

20 . STAND

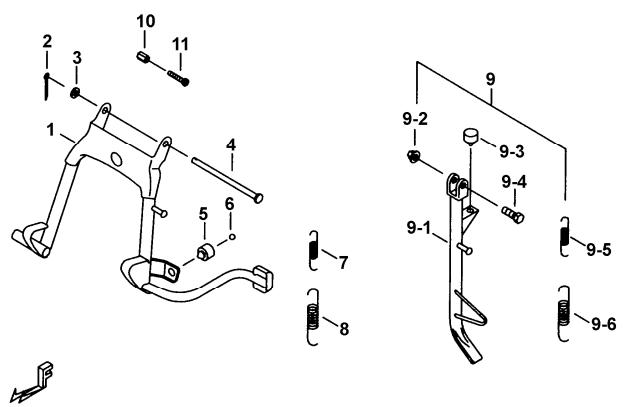

21 .FUEL TANK

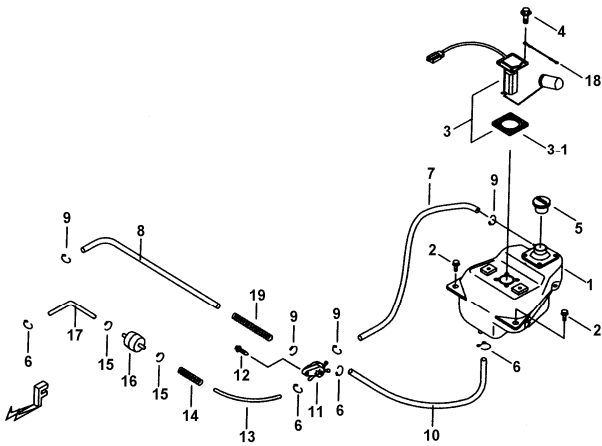

22 .OIL TANK

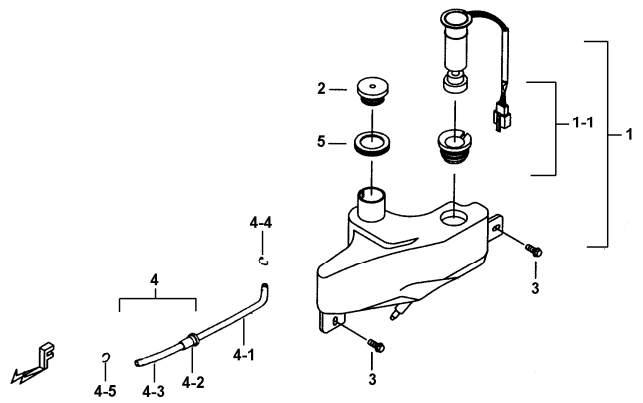

23 . SEAT

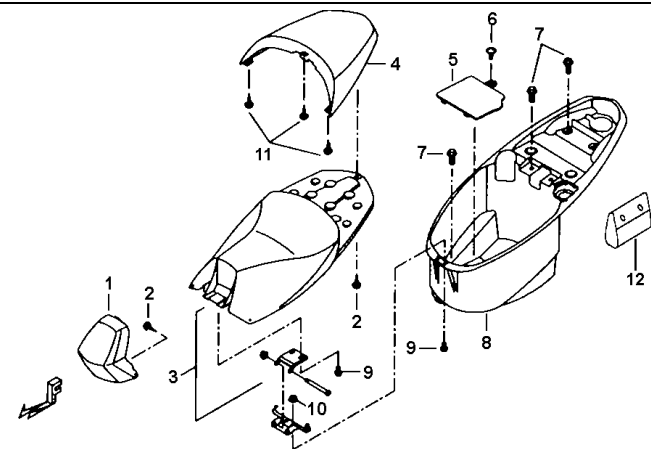

24 . ADDITIONS OF SIDE COVER

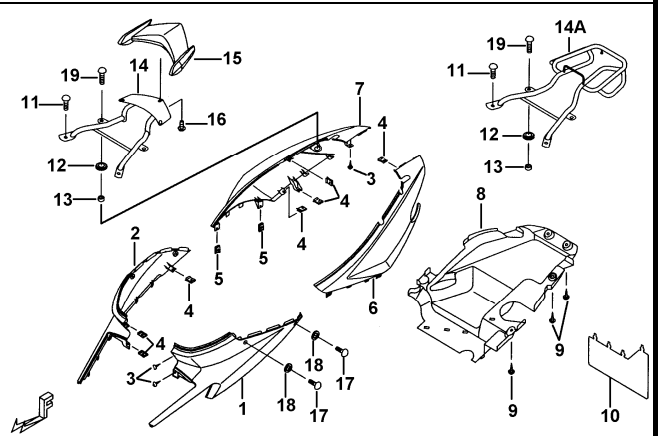

**25 . FRONT LEG SHIELD**

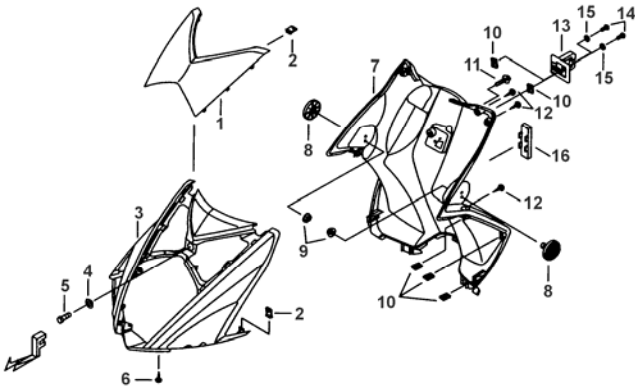

**26 . REAR LEG SHIELD**

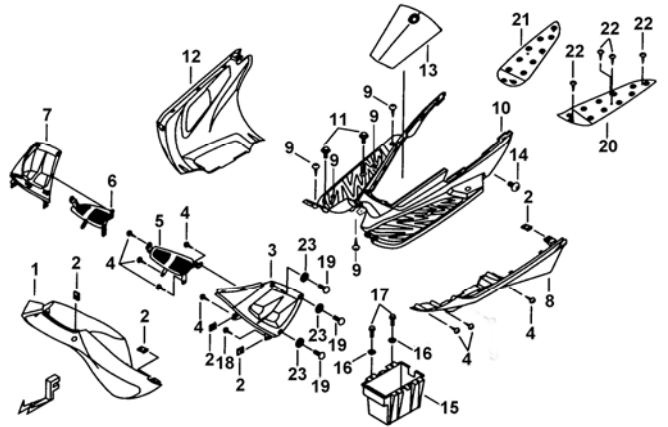

**27 . FRONT FORK**

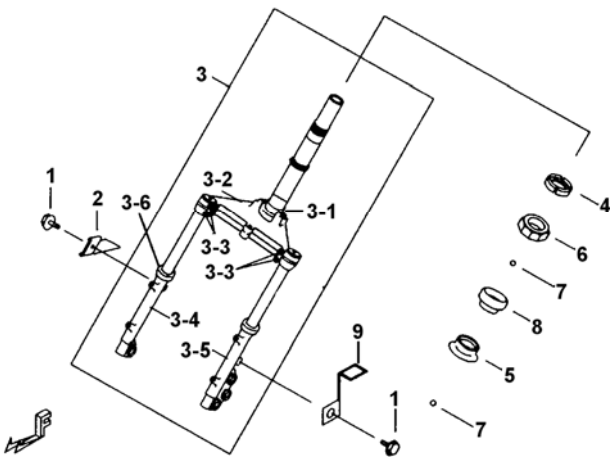

**28 . FRONT FENDER**

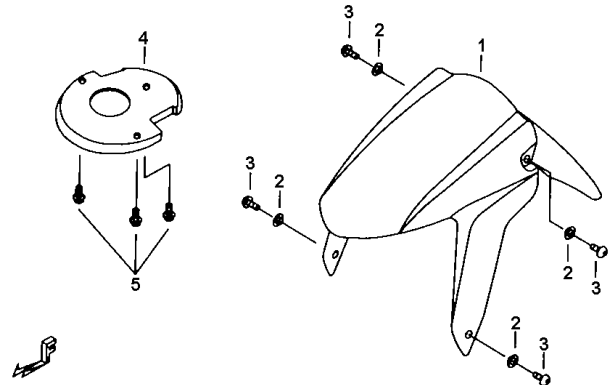

**29 . FRONT WHEEL**

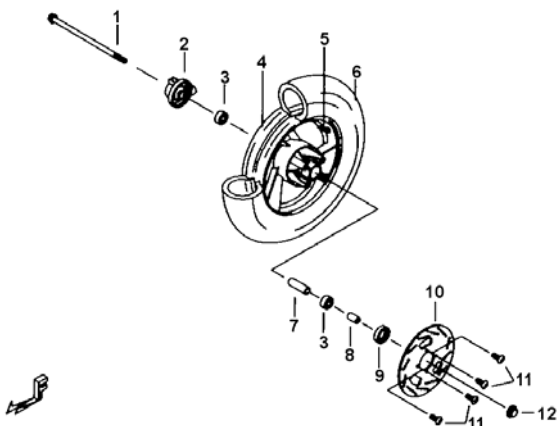

**30 . HANDLE BAR**

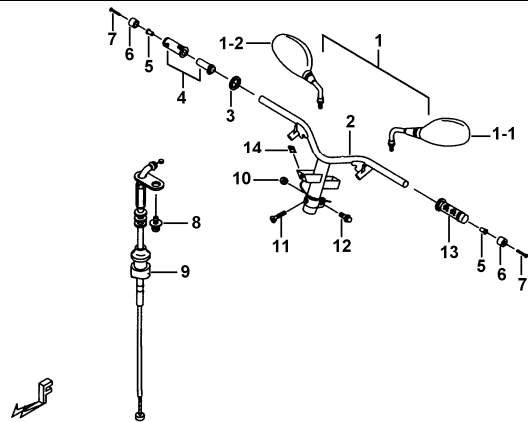



**31 . HANDLE BAR COVER**

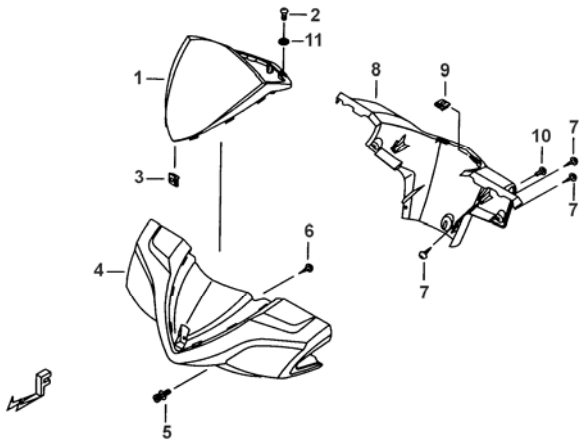

**3101. WIND-SHIELD ASSY.**

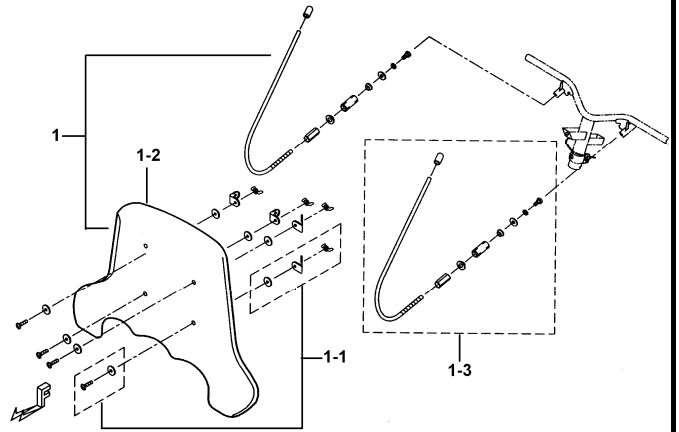

**3 2 . HANDLE BAR SWITCH**

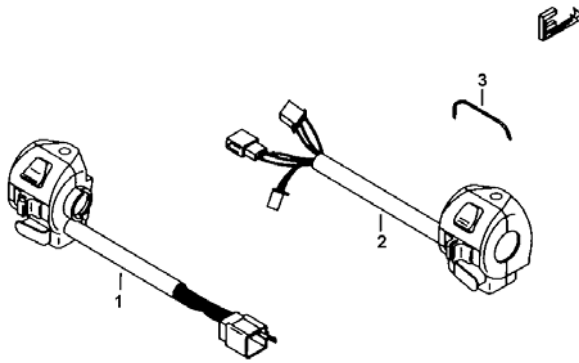

**3 3 . REAR FENDER**

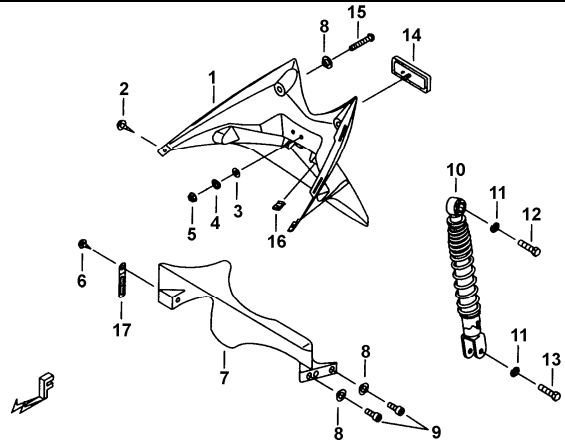

**3 4 . RAER WHEEL**

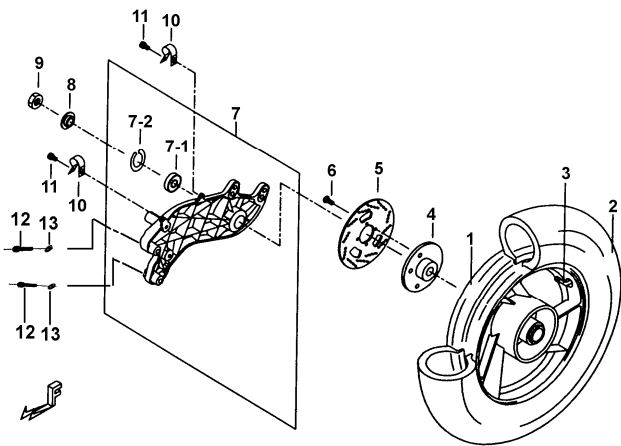

**35 . CALIPER, MASTER CYLINDER (FRONT)**

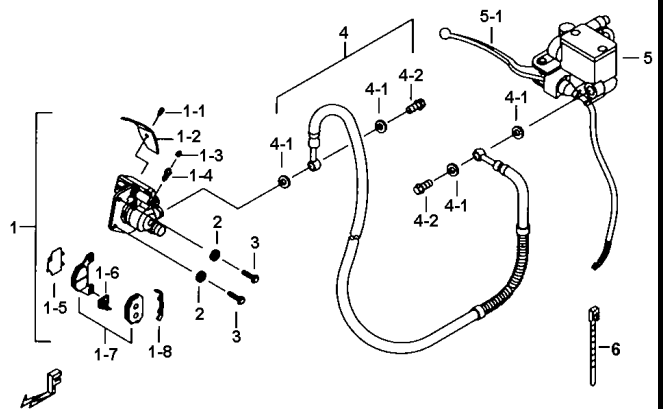

36. CALIPER, MASTER CYLINDER(REAR)

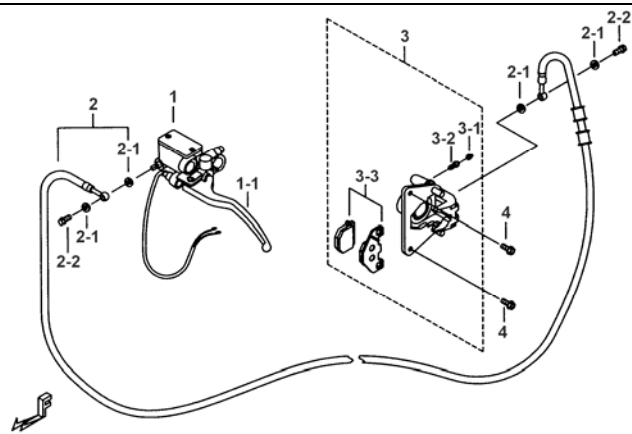

37. LABELS

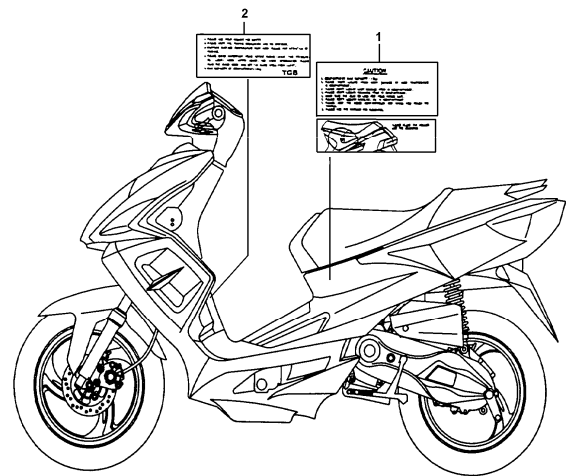

0

ENGINE ASSY.

BM1

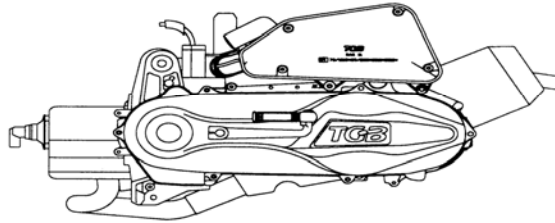

item_no	part_no	description	qty	amend	note1
01	GI5570400U	ENGINE ASSY.(EURO 2)	1		

**1 CYLINDER AND CRANK CASE COVER**

**BM1**

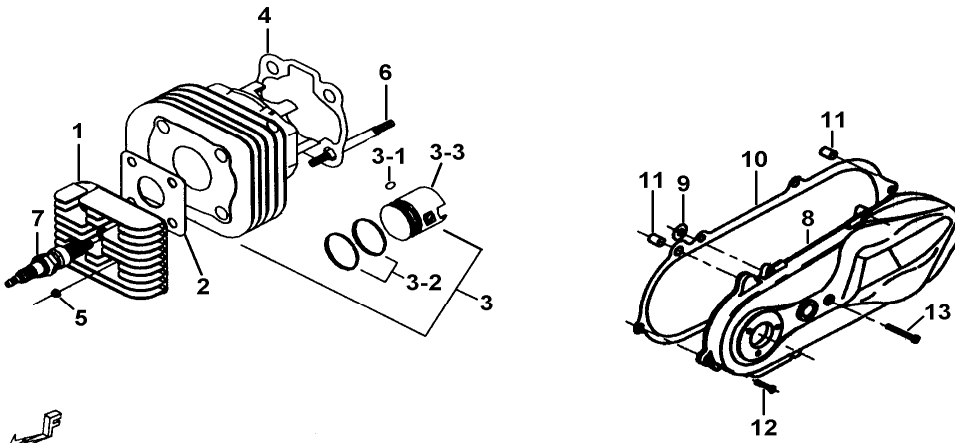

item_no	part_no	description	qty	amend	note1
01	GA504AL01	HEAD, CYLINDER	1		
02	GA504PK01	GASKET, CYLINDER HEAD	1		
03	GA5049911	CYLINDER SET, WITH PISTON, PISTON RING AND CIRCLIP	1		
03-1	GA505SR01	CIRCLIP $\phi$ 11	2		
03-2	GA5059905	RING SET, PISTON	1		
03-3	423046	PISTON	1		
04	GA504PK02	GASKET, CYLINDER	1		
05	GA504NT01	NUT, FLANGE M6	4		
06	GA504SC01	STUD M6X100	4		
07	GI5010005	SPARK PLUG BPR7HS	1		
08	GE501AL15	COVER, CLUTCH	1		
09	GA504PK11	WASHER	1		
10	GE501PK10	GASKET, CLUTCH	1		
11	GA504PN01	PIN, KNOCK 8.5x11x18	2		
12	S70610	SCREW, SOCKET HEAD M6x25	6		
13	S70611	SCREW, SOCKET HEAD M6x50	1		

2

## CRANK CASE

BM1

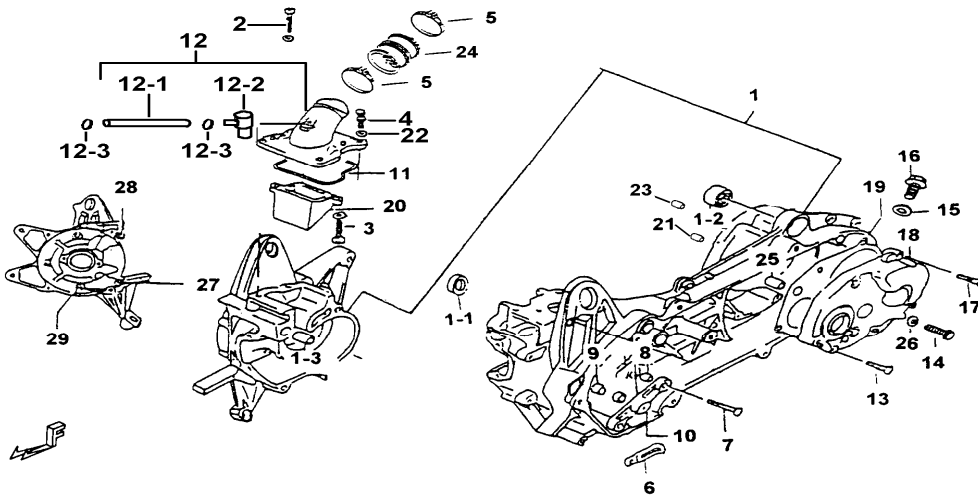

item_no	part_no	description	qty	amend	note1
01	422060	CRANK CASE COMP.	1		
01-1	GL502BR01YT	BEARING 17X35X10	2		
01-2	GA5049904	BUSH COMP.	1		
01-3	GA504PN01	PIN, KNOCK 8.5x11x18	2		
02	S79601	SCREW, SOCKET HEAD M6x20	3		
03	S79401	SCREW, SOCKET HEAD M4x20	2		
04	S71603	BOLT, BREAKABLE, HEX. HEAD M6X16	1		
05	422038	CLIP	2		
06	GA501SR01	CLAMP	1		
07	S70602	SCREW, HEX. SCCKET M6X1.0X25L	2		
08	GA504PN02	PIN, DOWEL 6.5x9x10	2		
09	GA504BS01	BUSH	1		
10	GA6029905	CAP SET, STARTER IDLE GEAR	1		
11	421008	GASKET, INTAKE PIPE	1		
12	421001A	PIPE ASSY., INTAKE	1		
12-1	GA605PP02	HOSE OIL	1		
12-2	GA5049909	VALVE ASSY., NON-RETURN	1		
12-3	R36501	CLIP	2		
13	S70602	SCREW, HEX. SCCKET M6X1.0X25L	5		
14	GA904SC12	BOLT, FLANGE M6X12	1		
15	GA504WS02	WASHER	1		
16	GA504SC12	BOLT, FLANGE 8X12	1		
17	S70603	SCREW, SOCKET HEAD M6x30	1		
18	GA602AL07	COVER, GEAR BOX	1		
19	GA504PK05	GASKET, GEAR BOX COVER	1		
20	GA5049907	VALVE ASSY., REED	1		
21	422054	PLUG	1		
22	GA504WS04	WASHER, SPRING	1		
23	422056	PLUG	1		

24	421002	RUBBER TUBE	1
25	GA504PN01	PIN, KNOCK 8.5x11x18	2
26	W99601	WASHER 6X12X2	1
27	S70606	SCREW, SOCKET HEAD M6x75	1
28	S70605	SCREW, SOCKET HEAD M6x85	1
29	S70601	SCREW, SOCKET HEAD M6X45	3

3

## CRANK SHAFT

BM1

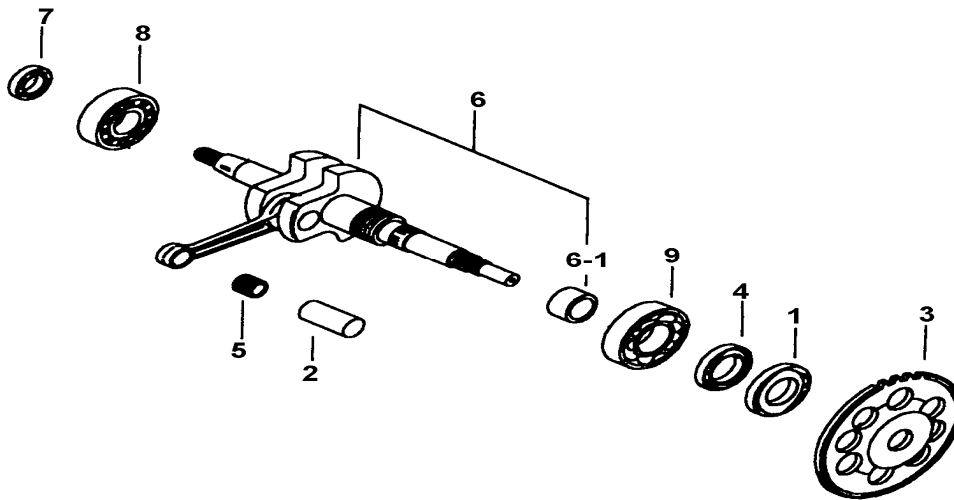

item_no	part_no	description	qty	amend	note1
01	GA505OS03	SEAL, OIL 24X43X6	1		
02	GA505PN01	PIN, PISTON	1		
03	GA505FE05	GEAR, STARTER	1		
04	GA505OS02	OIL SEAL, LH. 25X37X6	1		
05	GA505BR01A	BEARING, PISTON PIN 10X14X12.5	1		
06	GA5050006	CRANK SHAFT ASSY.	1		
06-1	GA505BS01	SPACER 18X24X14	1		
07	GA505OS01	OIL SEAL, RH. 17X27X6	1		
08	GA505BR03	BEARING, RH. 20X47X14	1		
09	GA505BR04	BEARING, LH. 25X52X13	1		

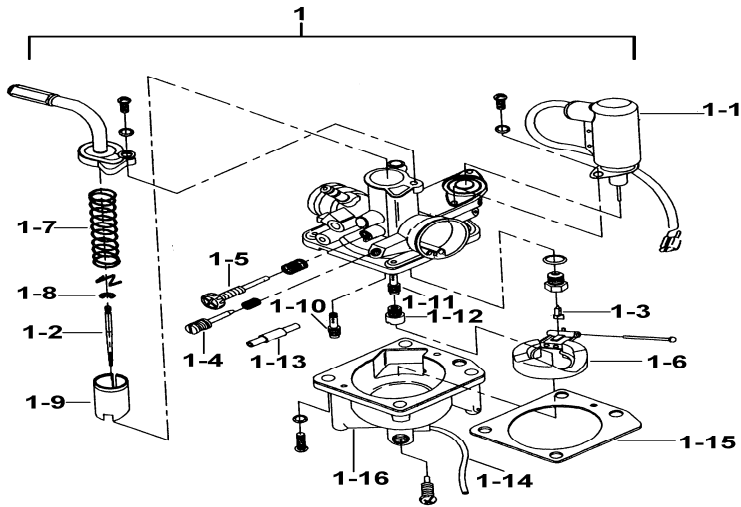

item_no	part_no	description	qty	amend	note1
01	424026A	CARBURETOR ASSY.	1		
01-1	GA5089905	ELEMENT ASSY., THERMO	1		
01-10	GA508CU13	IDLE JET	1		
01-11	424014	MAIN NOZZLE	1		
01-12	GA508CU01	MAIN JET M.J.60	1		
01-13	425016	OIL CHECK VALVE B (LINEAR TYPE)	1		
01-14	424018	CARBURETTOR DRAIN TUBE	1		
01-15	424031	GASKET SET	1		
01-16	424043	CHAMBER SET, FLOAT	1		
01-2	GA508AL01	NEEDLE, JET	1		
01-3	GA508FE05	VALVE, NEEDLE	1		
01-4	GA5089907	SCREW SET, AIR	1		
01-5	GA5089908	SCREW SET, IDLE SPEED	1		
01-6	GA508PL10	FLOAT	1		
01-7	424080	SPRING	1		
01-8	424012	SNAP RING C TYPE	1		
01-9	424013	VALVE, THROTTLE	1		



5

OIL PUMP

BM1

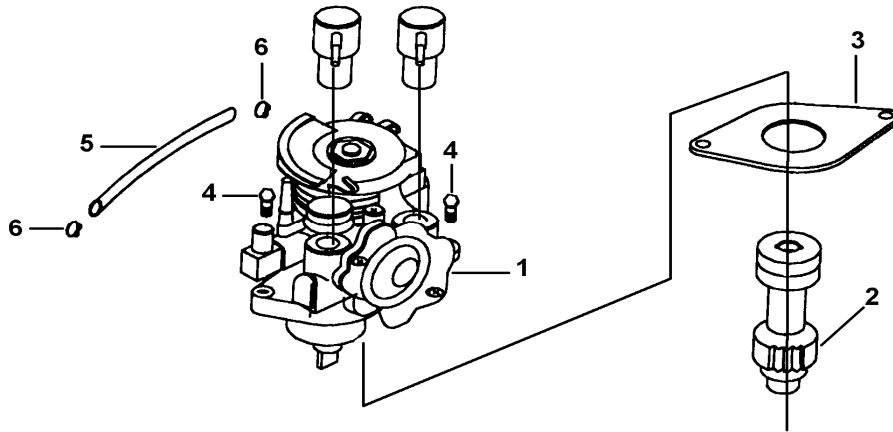

item_no	part_no	description	qty	amend	note1
01	425051	PUMP ASSY., OIL	1		
02	GA508PL01	GEAR, OIL PUMP DRIVEN	1		
03	GA508PK01	GASKET, OIL PUMP	1		
04	S79501	SCREW, SOCKET HEAD M5x16	2		
05	GA605PP02	HOSE OIL	1		
06	R36501	CLIP	2		

6

## CONTINUOUS VARIABLE TRANSMISSION

BM1

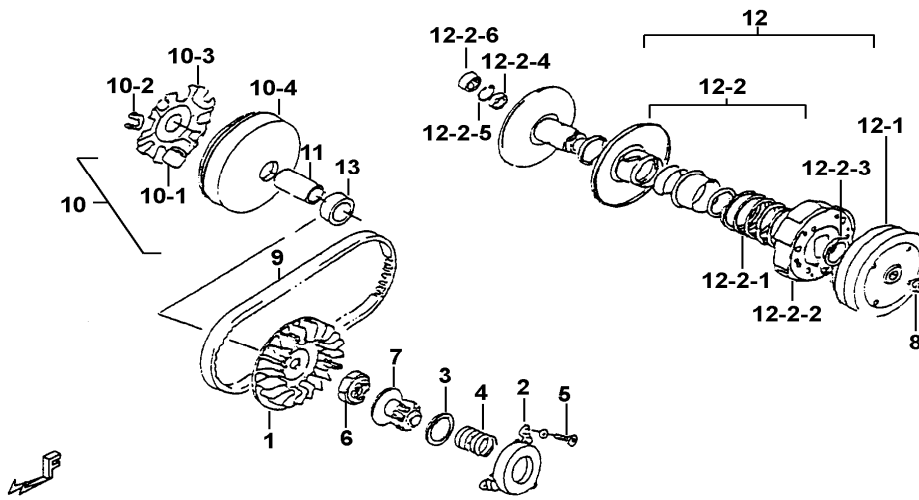

item_no	part_no	description	qty	amend	note1
01	GA906AL01A	FACE, FIXED DRIVE	1		
02	GA906FE01A	HOLDER, KICK DRN GEAR SPRING	1		
03	GA506WS02	WASHER	1		
04	GA506SP01	SPRING 30.5X24.9	1		
05	S79605	SCREW, SOCKET HEAD	3		
06	GA906FE04	STARTER, KICK RH.	1		
07	GA5069904	STARTER SET, KICK LH.	1		
08	GA501NT01	NUT, FLANGE M10	1		
09	GE506RB01	V-BELT, DRIVE	1		
10	490048	PULLEY COMP., DRIVE	1		
10-1	490045	ROLLER COMP., MOVABLE DRIVE FACE	6		
10-2	PG289931	GUIDE, MOVABLE DRIVE FACE PLATE	3		
10-3	490044	PLATE, FIXED DRIVE	1		
10-4	490041	FACE COMP., DRIVE MOVABLE	1		
11	A02806FE01	SPACER	1		
12	490291	PULLEY COMP., DRIVEN	1		
12-1	PG289933	HOUSING COMP., CLUTCH	1		
12-2	490051	PULLEY ASSY., DRIVEN	1		
12-2-1	PT506SP02	SPRING, MOVABLE DRIVEN FACE	1		
12-2-2	490498	CLUTCH ASSY., SHOE	1		
12-2-3	A02806NT01	NUT, HEX. M28	1		
12-2-4	490385	BEARING	1		
12-2-5	A02806SR01	CIR-CLIP	1		
12-2-6	490384	NEEDLE BEARING	1		
13	428000	SPACER 6.0	1		

7

MUFFLER

BM1

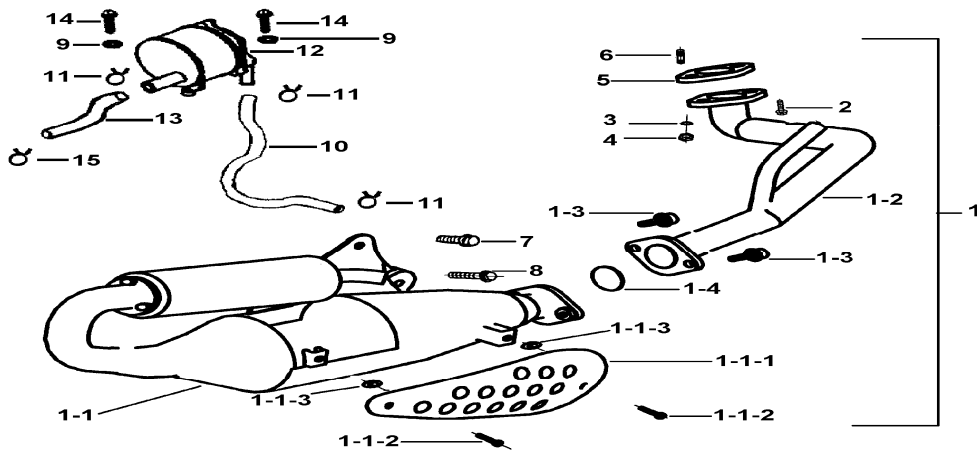

item_no	part_no	description	qty	amend	note1
01	426161	BODY COMP., MUFFLER	1		
01-1	426171	BODY, MUFFLER	1		
01-1-1	426176	COVER, MUFFLER	1		
01-1-2	S45605	SCREW, OVAL HEAD M6X12	2		
01-1-3	W99506	WASHER	2		
01-2	426172	PIPE, MUFFLER	1		
01-3	S96803	SCREW, SPECIAL	2		
01-4	426104	GASKET, MUFFLER	1		
02	S96601	SCREW, SPECIAL	1		
03	GA504WS04	WASHER, SPRING	1		
04	GA509NT01	NUT, HEX. HEAD M6	1		
05	GA509PK01	GASKET, EXHAUST PIPE	1		
06	GA509SC06	STUD M6X25	1		
07	S20801	BOLT, FLANGE M8X20	1		
08	S20802	BOLT, FLANGE	1		
09	W99602	WASHER 6.5X12X1.0	2		
10	426173	HOSE, RUBBER	1		
11	426081	CLIP	3		
12	426141	SECOND-AIR CONTROL ASSY.	1		
13	426085	HOSE, RUBBER	1		
14	S70607	SCREW, SOCKET HEAD M6X20	2		
15	R40902	CLIP	1		

8

## COOLING FAN

BM1

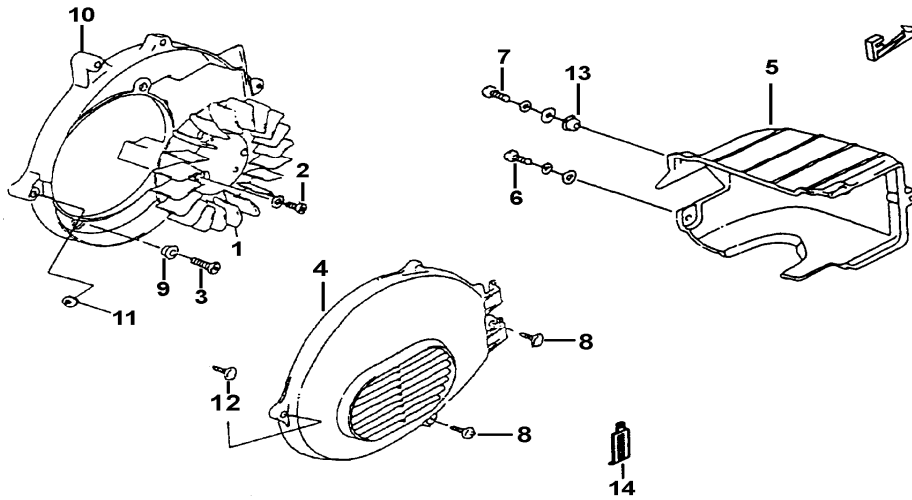

item_no	part_no	description	qty	amend	note1
01	427044	FAN, COOLING	1		
02	S79602	SCREW, SOCKET HEAD M6x16	4		
03	S70609	SCREW, SOCKET HEAD M6x16	4		
04	GA608PL11	COWLING, FAN	1		
05	427002E	COWLING, CYLINDER ASSY.	1		
06	S71602	SCREW, SOCKET HEAD M6x40	1		
07	S71601	SCREW, SOCKET HEAD M6X20	1		
08	GA509SC02	SCREW, TAPPING M6x20	4		
09	GA509WS05	WASHER 6X13X6	4		
10	GE508PL14	CASE, FAN	1		
11	420009	SPACER	1		
12	GA509SC20	SCREW, TAPPING	1		
13	427006	WASHER	1		
14	GA501SR01	CLAMP	1		

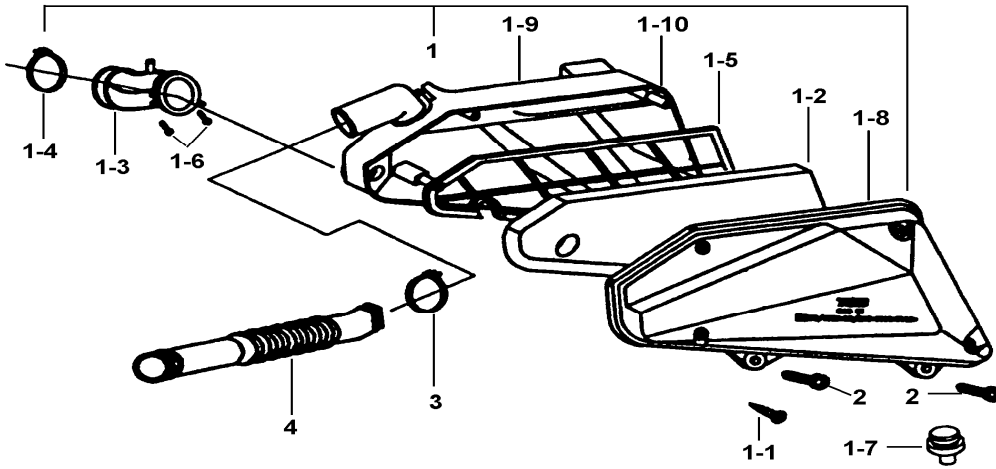

item_no	part_no	description	qty	amend	note1
01	420085	CLEANER ASSY., AIR	1		
01-1	S51502	SCREW, TAPPING	4		
01-10	420068	GASKET	1		
01-2	420031	FILTER	1		
01-3	420003	TUBE, OUTLET	1		
01-4	422039	CLAMP. $\phi$ 38	1		
01-5	420041	DIVISION PLATE	1		
01-6	S50402	SCREW, TAPPING M4X10	2		
01-7	420072	PLUG, LEAK	1		
01-8	420039	COVER, UPPER	1		
01-9	420086	COVER, LOWER $\phi$ 15.5	1		
02	S70603	SCREW, SOCKET HEAD M6x30	2		
03	422037	CLIP $\phi$ 32	1		
04	GA904PL09	DUCT, COOLING	1		

**10 REDUCING GEAR**

**BM1**

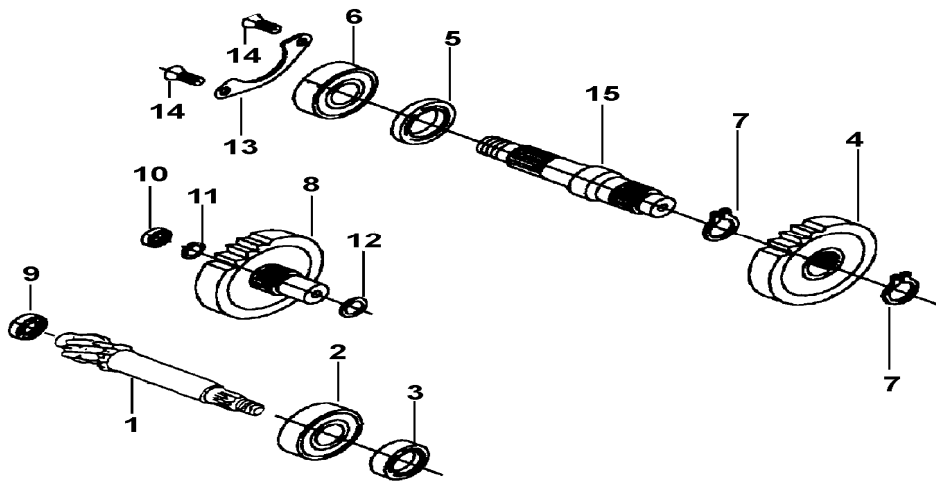

item_no	part_no	description	qty	amend	note1
01	427529	SHAFT, DRIVE 15T	1		
02	GA507BR04	BEARING, DRIVE SHAFT, LH. 17x47x14	1		
03	GA507OS01	OIL SEAL, DRIVE SHAFT 17x27x5	1		
04	427535	GEAR, FINAL DRIVEN 35T	1		
05	GA507OS02	OIL SEAL, REAL AXLE 27x40x6	1		
06	GA507BR06	BEARING, GEAR AXLE, RH. 20x47x14	1		
07	GA507SR02	CIRCLIP, FINAL DRIVEN GEAR $\phi$ 22	2		
08	427539	SHAFT COMP., IDLE 51T/10T	1		
09	GA507BR03	BEARING, DRIVE SHAFT, RH. 12X32X10	1		
10	GA507BR02	BEARING, IDLER, RH. 12x32x10	1		
11	GA507WS01	WASHER	1		
12	GA507WS02	WASHER, IDLE SHAFT, LH.	1		
13	GA507FE04	RETAINER, REAR AXLE BEARING	1		
14	GA507SC01	SCREW, BEARING RETAINER M6x16	2		
15	427540	SHAFT, REAR AXLE	1		

11

KICK STARTER

BM1

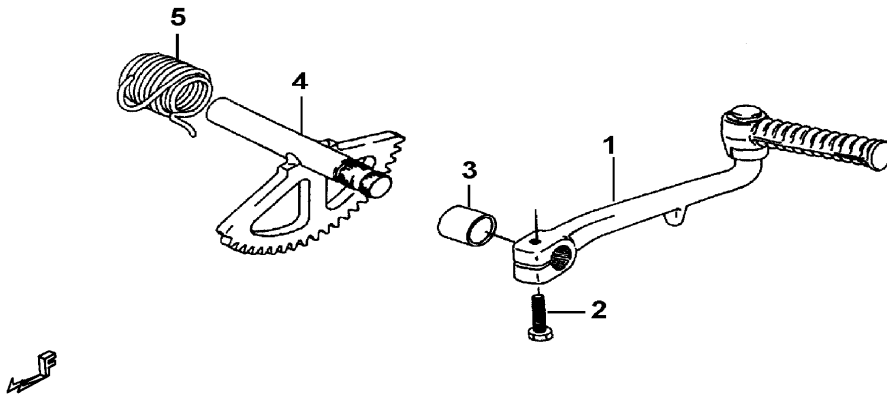

item_no	part_no	description	qty	amend	note1
01	GA9059911	LEVER ASSY., KICK STARTER	1		
02	GA905SC01	BOLT, HEX. HEAD M8X22	1		
03	GA505BS05	BUSH, KICK STARTER SHAFT	1		
04	GA5059910	SHAFT COMP., STARTER	1		
05	GA505SP01	SPRING, KICK STARTER SHAFT	1		

12

## STARTING MOTOR

BM1

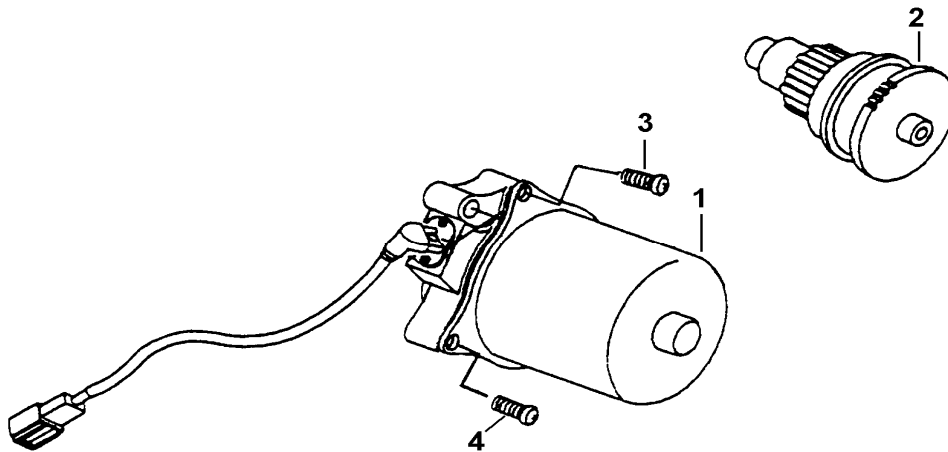

item_no	part_no	description	qty	amend	note1
01	GA9029901	MOTOR ASSY., STARTING	1		
02	GA9029902	PINION GEAR ASSY.	1		
03	S70602	SCREW, HEX. SCCKET M6X1.0X25L	1		
04	S70603	SCREW, SOCKET HEAD M6x30	1		



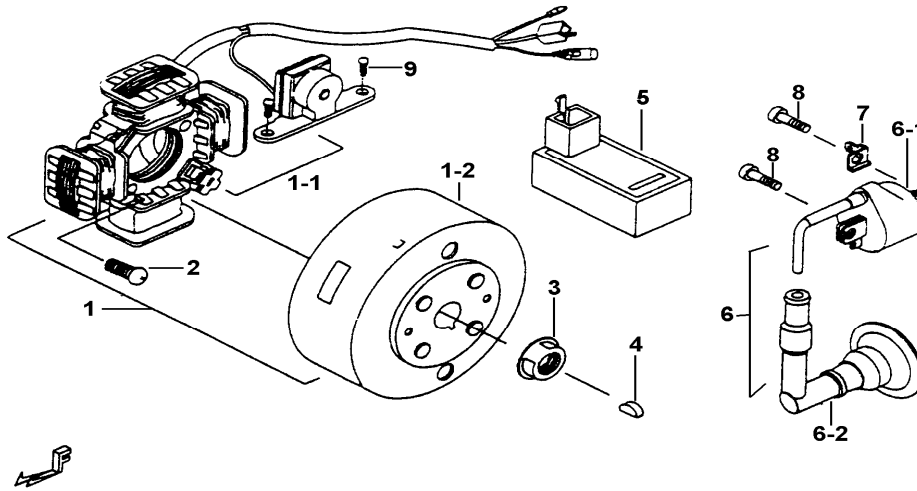

item_no	part_no	description	qty	amend	note1
01	440931	FLYWHEEL MAGNETO ASSY.	1		
01-1	GE5139904	STATOR ASSY.	1		
01-2	440938	ROTOR ASSY.	1		
02	S79603	SCREW, SOCKET HEAD M6X25	2		
03	GA501NT01	NUT, FLANGE M10	1		
04	GA501KY01	KEY	1		
05	GE5139902	C.D.I (UNLIMITED SPEED)	1		
06	GE5139903	COIL ASSY., IGNITION	1		
06-1	GE5139906	COIL SET, IGNITION	1		
06-2	GE513RB01	CAP SET, SPARK PLUG	1		
07	440564	EARTH TERMINAL	1		
08	S70607	SCREW, SOCKET HEAD M6X20	2		
09	S79503	SCREW, SOCKET HEAD	2		

**14 BATTERY, HORN, RELAY, RECTIFIER**

**BM1**

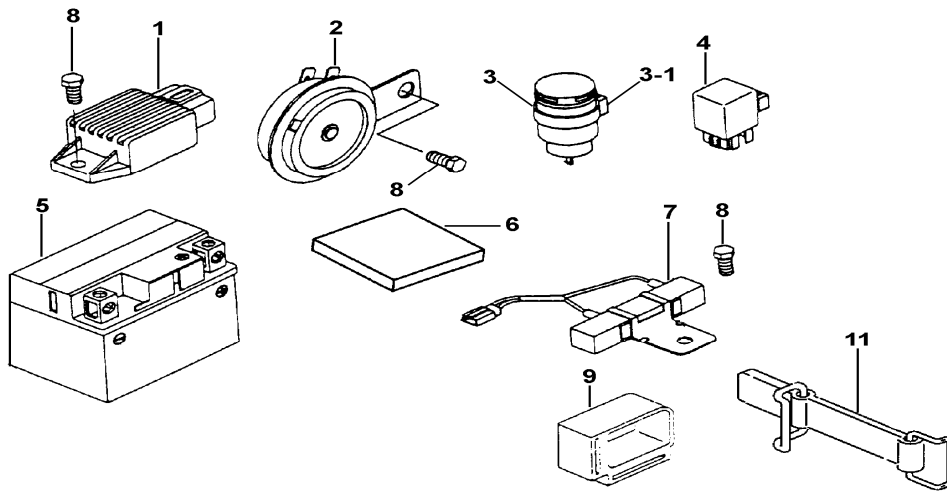

item_no	part_no	description	qty	amend	note1
01	GA5140001	RECTIFIER ASSY.	1		
02	GF5149906	HORN ASSY.	1		
03	440800A	RELAY, TURN SIGNAL	1		
03-1	440745	BUSH, RUBBER	1		
04	GA5100004	RELAY	1		
05	440805	BATTERY 12V 9AH	1		
06	GF514TH02	CUSHION	4		
07	400587	RESISTOR SET	1		
08	GA510SC03	SCREW, HEX. HEAD M6X16	3		
09	GE514RB02	BUSH, RUBBER	1		
11	526405	BAND, BATTERY	1		

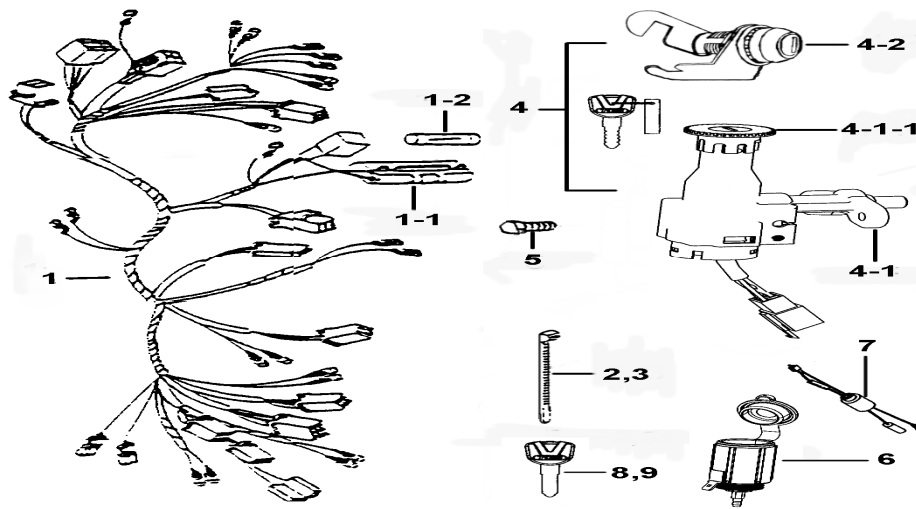

item_no	part_no	description	qty	amend	note1
01	440985	WIRING HARNESS	1		
01-1	GF5159906	CASE SET, FUSE	1		
01-2	GF5159907	FUSE 7A	1		
02	400535	CLAMP L300	2		
03	GA510SR02	CLAMP L200	1		
04	440979	LOCK ASSY.	1		
04-1	440991	LOCK SET, STEERING	1		
04-1-1	440996	CAP, INDICATOR	1		
04-2	440992-S	LOCK	1		
05	S96601	SCREW, SPECIAL	2		
06	440986	POWER SOURCE	1		
07	440990	CONNECT WIRE	1		
08	440997	BLANK KEY	1		
09	440998	BLANK KEY	1		

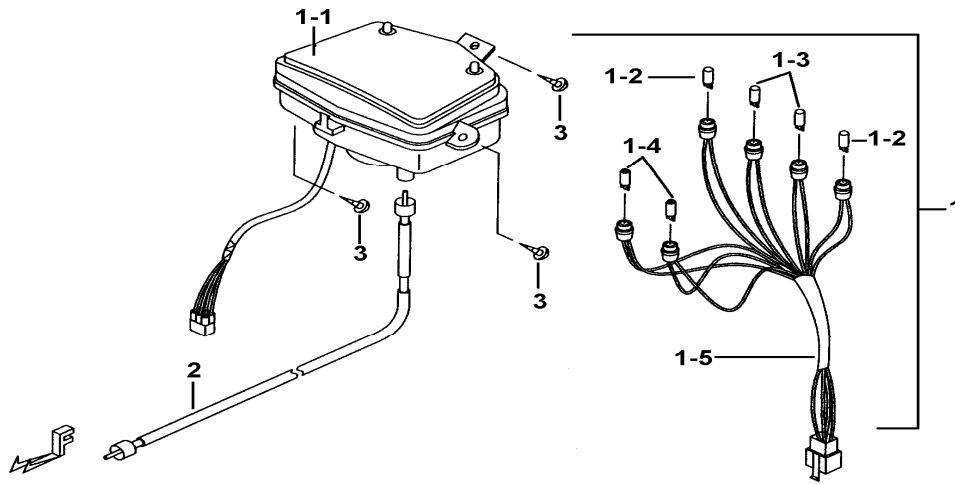

item_no	part_no	description	qty	amend	note1
01	457131	SPEEDOMETER ASSY.	1		
01-1	457116	COVER, SPEEDOMETER	1		
01-2	457118	BULB 14V 3W	2		
01-3	GA5520009	BULB (12V, 1.7W)	2		
01-4	410154	BULB, BLACK HEAD(12V,1.7W)	2		
01-5	457117	SOCKET COMP.	1		
02	411630	CABLE ASSY., SPEEDOMETER	1		
03	GA552SC11	SCREW, TAPPING M4X16	3		

17 HEAD LAMP AND FRONT TURN SIGNAL LAMP

BM1

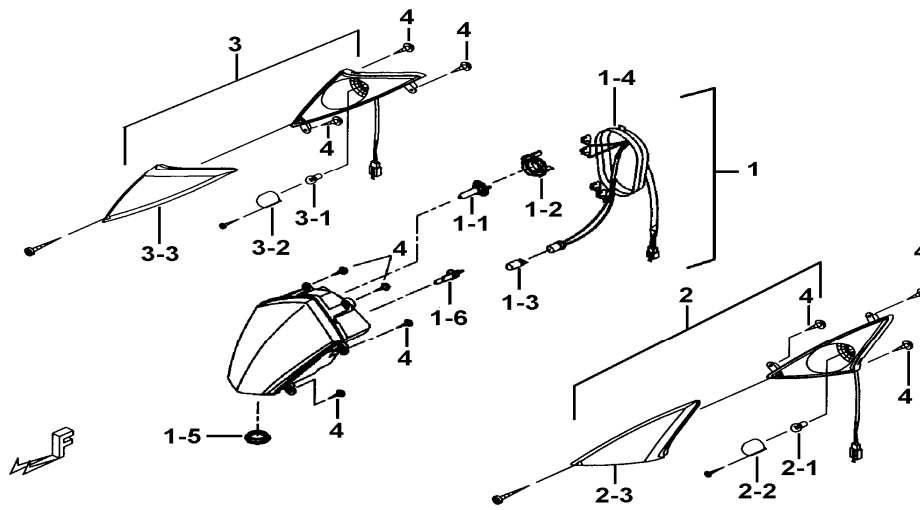

item_no	part_no	description	qty	amend	note1
01	450039Y	HEAD LAMP ASSY.	1		
01-1	450067Y	BULB 55W	1		
01-2	450066Y	BRACKET, BULB	1		
01-3	400517	BULB 12V, 5W	1		
01-4	450069Y	SOCKET COMP.	1		
01-5	450070Y	RUBBER PLUG	1		
01-6	450068Y	BULB 55W	1		
02	450040	TURN SIGNAL LAMP COMP., LH.	1		
02-1	GF5170006	BULB, 12V, R10W	1		
02-2	450059	LENS	1		
02-3	450056	LENS, TURN SIGNAL, LH. FRONT	1		
03	450041	TURN SIGNAL LAMP COMP., RH.	1		
03-1	GF5170006	BULB, 12V, R10W	1		
03-2	450059	LENS	1		
03-3	450057	LENS, TURN SIGNAL, RH. FRONT	1		
04	GA552SC11	SCREW, TAPPING M4X16	12		

**18 REAR LAMP CLUSTER**

**BM1**

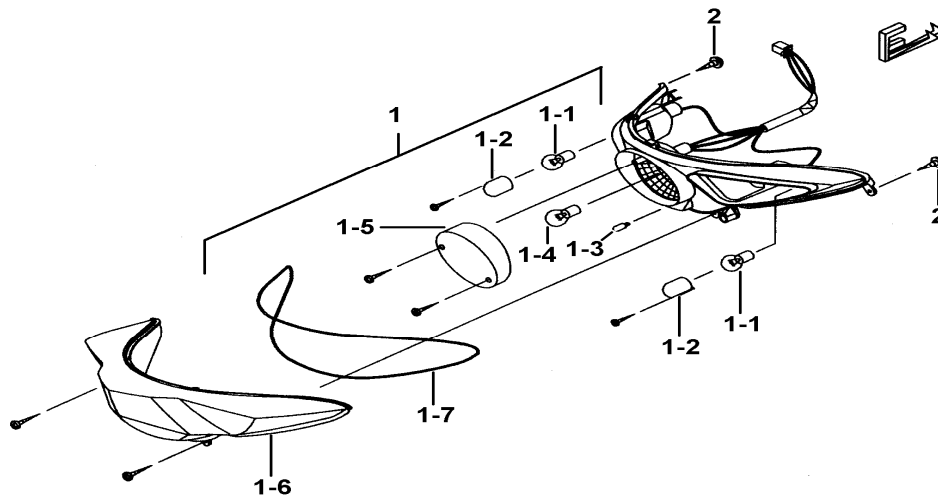

item_no	part_no	description	qty	amend	note1
01	451029	REAR LAMP ASSY.	1		
01-1	GF5170006	BULB, 12V, R10W	2		
01-2	451045	LENS	2		
01-3	400517	BULB 12V, 5W	1		
01-4	GF5180002	BULB 12V, P21/5W	1		
01-5	451044	LENS, REAR LAMP	1		
01-6	451043	LENS, REAR LAMP	1		
01-7	451046	GASKET	1		
02	S50401	SCREW TAPPING M4X12	2		

19

FRAME

BM1

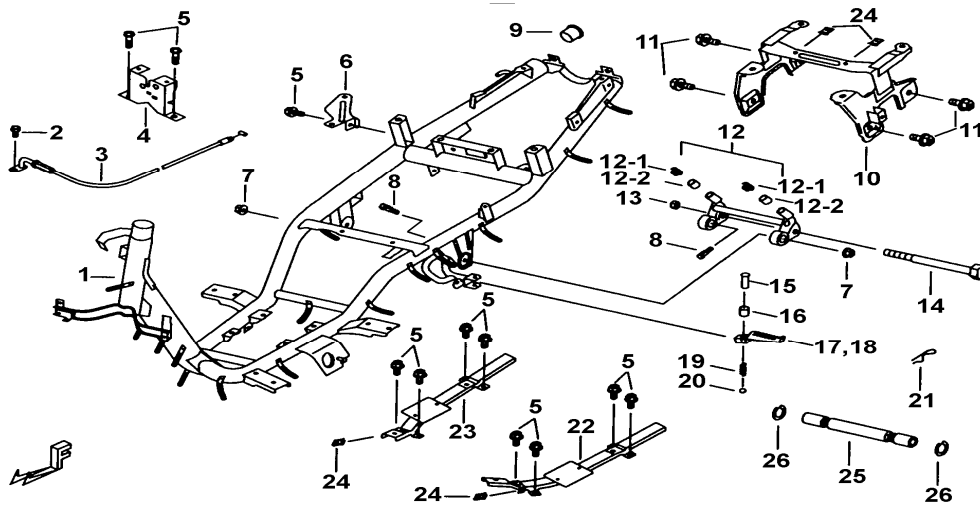

item_no	part_no	description	qty	amend	note1
01	411975	FRAME	1		
02	S13502	SCREW,CROSS RECESSED,PAN HEAD M5X10	1		
03	411977	CABLE, LOCK SET, SEAT	1		
04	BH1199904	LOCK SET, SEAT	1		
05	GA556SC01	BOLT, FLANGE M6X1.0X12L	11		
06	411981	BRKT, 2ND AIR	1		
07	GA551NT01	NUT, SELFLOCK M10X1.0	2		
08	S06001	BOLT, HANGER	2		
09	411972	RUBBER CAP	1		
10	411982	BRKT COMP., HANDLE	1		
11	GA551SC02	BOLT	4		
12	401797	ROCKER ARM ASSY., HANGER	1		
12-1	401794	COMPRESSION SPRING	2		
12-2	GI519RB01	DAMPER, RUBBER	2		
13	N25201	NUT, SELFLOCK M12X1.25	1		
14	S21203	BOLT, HEX. HEAD	1		
15	GA551PN02	PIN 6X34	2		
16	GF519FE01	COLLAR, PIN 6X8X20	2		
17	GF519AL05	FOOTREST ASSY., PILLON, LH.	1		
18	GF519AL06	FOOTREST ASSY., PILLION, RH.	1		
19	GF519SP01	SPRING, COMPRESSION 6X12.5	2		
20	GF519FE04	BALL $\phi$ 6.35	2		
21	GA551PN01	COTTER PIN 1.5X30	2		
22	411983	L REINFORCEMENT FLOOR COMP.	1		
23	411984	R REINFORCEMENT FLOOR COMP.	1		
24	N32601	NUT, SPRING	4		
25	BH102FE01	SLEEVE, HANGER	1		
26	R00701	RETAINER RING, C TYPE $\phi$ 16	2		

20

STAND

BM1

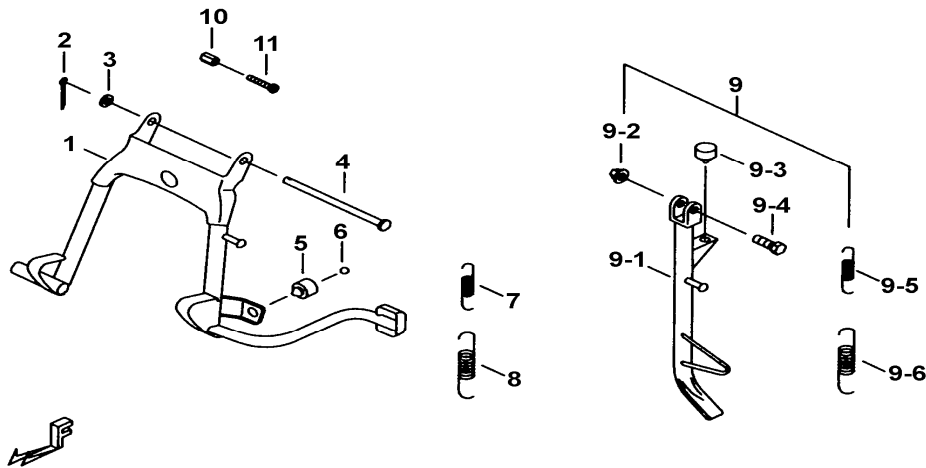

item_no	part_no	description	qty	amend	note1
01	412050	STAND COMP., MAIN	1		
02	GA551PN04	PIN, COTTER	1		
03	W99806	WASHER 8.5X16X2	1		
04	GA551PN03	SHAFT, MAIN STAND	1		
05	401701	CUSHION	1		
06	GF519FE04	BALL $\phi$ 6.35	1		
07	GA551SP04	SPRING 9X107X1.4	1		
08	GA551SP02	SPRING 16X114X2.8	1		
09	413988	STAND COMP., SIDE	1		
09-1	412047	SIDE STAND COMP.	1		
09-2	GA551NT02	NUT, FLANGE SELRLOCK M10x10	1		
09-3	GA551RB05	CUSHION	1		
09-4	GA551SC03	BOLT	1		
09-5	402161	SPRING, SIDE STAND	1		
09-6	402160	SPRING, SIDE STAND	1		
10	GA551NT03	NUT	1		
11	GA551SC04	BOLT	1		



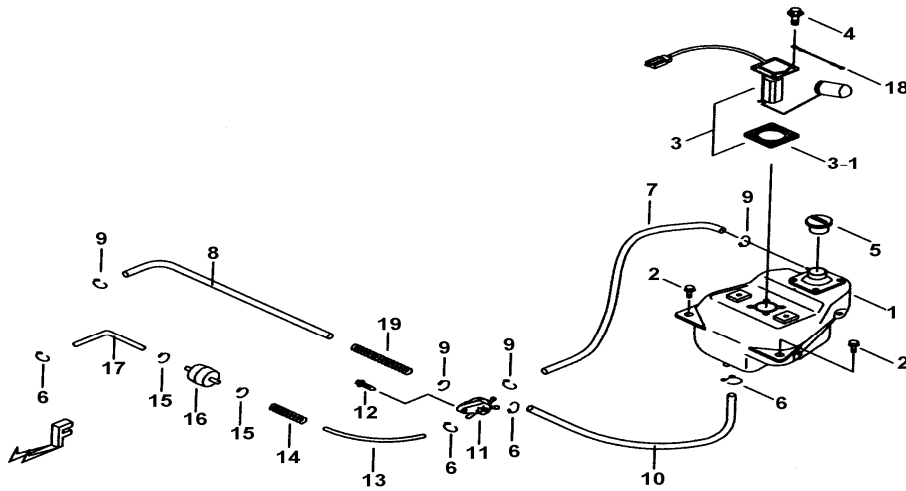

item_no	part_no	description	qty	amend	note1
01	412124	TANK, FUEL	1		
02	GA555SC05	BOLT, OUTLET M6X1.0X16L	4		
03	401813	GAUGE ASSY., FUEL LEVEL	1		
03-1	401710	GASKET	1		
04	S07501	BOLT,HEX HEAD	4		
05	412133	CAP COMP., FILLER	1		
06	R36801	CLIP $\phi$ 8.5	4		
07	BH121PP01	HOSE, NEGATIVE PRESSURE	1		
08	412131	HOSE	1		
09	GA553SR04	CLIP $\phi$ 7.5	4		
10	412132	HOSE	1		
11	GA5539902	COCK ASSY., FUEL	1		
12	GA553SC01	BOLT, FLANGE M6X1.0X16L	1		
13	412112	HOSE, NEGATIVE PRESSURE #6	1		
14	412134	SPRING 160L	1		
15	R36901	CLIP	2		
16	GA5539904	FILTER, FUEL	1		
17	412103	HOSE #2	1		
18	412120	HARNESS, EARTH	1		
19	412135	SPRING 250L	1		

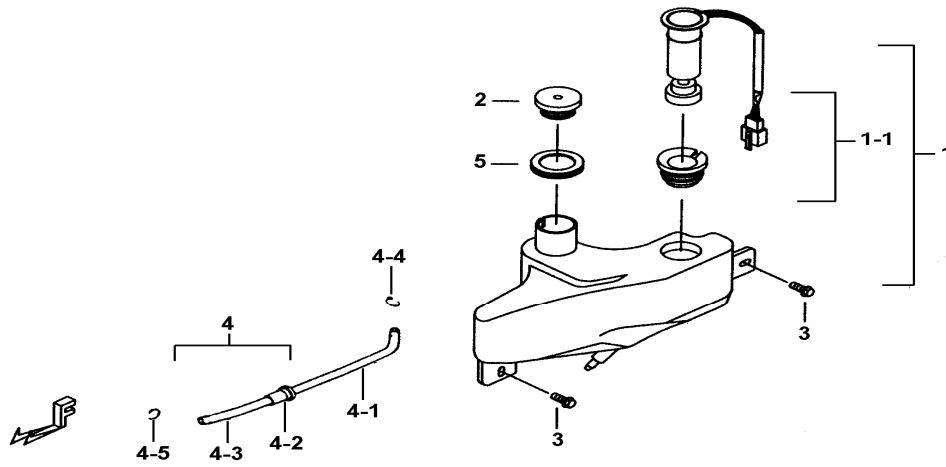

item_no	part_no	description	qty	amend	note1
01	412202	TANK, OIL COMP.	1		
01-1	BH1229901	SWITCH ASSY., OIL LEVEL	1		
02	GA553RB05	CAP, OIL TANK	1		
03	GA551SC09	BOLT, FLANGE M6X20	2		
04	425054	CLEANER COMP., OIL	1		
04-1	425057	HOSE	1		
04-2	425005	CLEANER ASSY., OIL	1		
04-3	425050	HOSE	1		
04-4	R36802	CLIP	3		
04-5	R50901	CLIP $\phi$ 9.5	1		
05	GA553RB04	RUBBER, OIL TANK INLET	1		

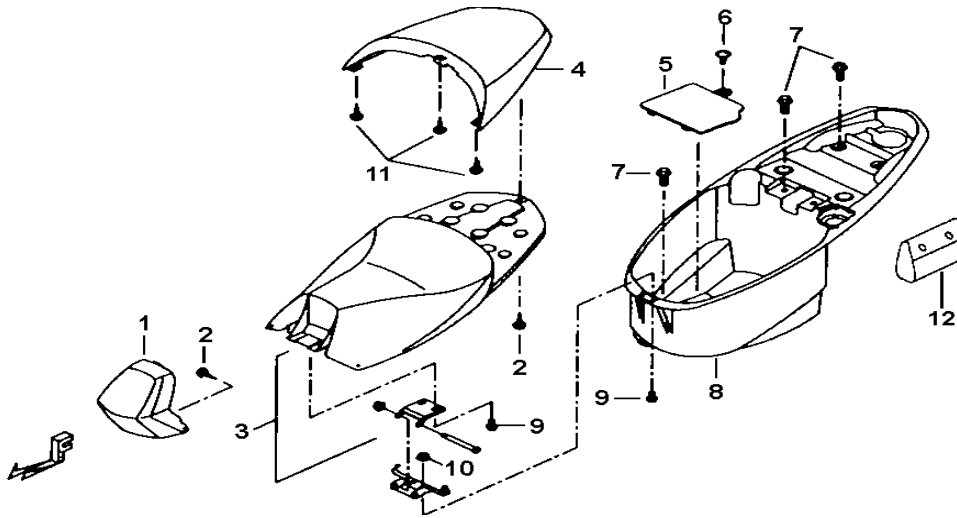

item_no	part_no	description	qty	amend	note1
01	452051	COVER, SEAT, FRONT	1		
02	S50401	SCREW TAPPING M4X12	3		
03	452059	FRONT SEAT	1		
04	452057	COVER, SEAT, REAR	1		
05	452056	CAP, HELMET CASE	1		
06	S45603	SCREW, OVAL HEAD M6x10	1		
07	S25602	BOLT M6X16L	6		
08	452060	HELMET CASE	1		
09	GA555SC05	BOLT, OUTLET M6X1.0X16L	4		
10	N10603	NUT, SPRING	2		
11	GA552SC11	SCREW, TAPPING M4X16	3		
12	421516	PACKAGE, TOOL	1		

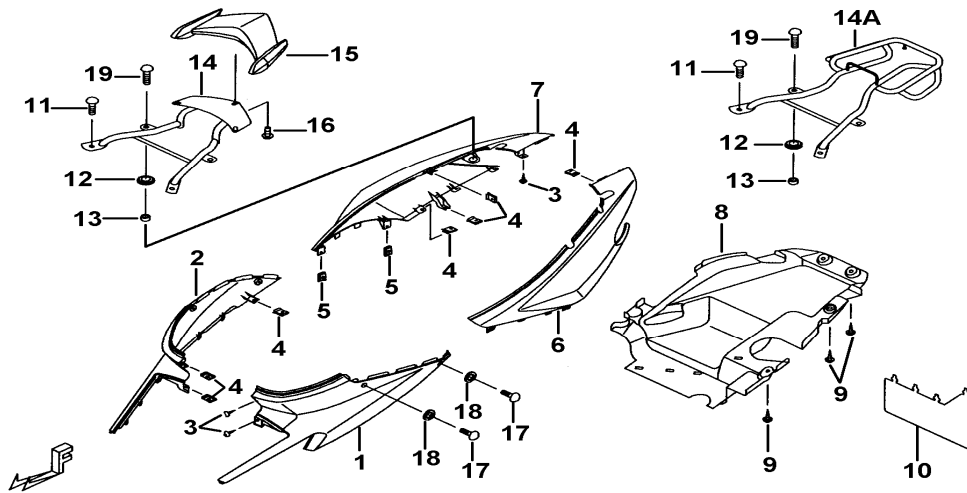

item_no	part_no	description	qty	amend	note1
01	453051	COVER, SIDE FRONT, LH.	1		
02	453052	COVER, SIDE FRONT, RH.	1		
03	S50401	SCREW TAPPING M4X12	3		
04	GA552NT01	NUT, SPRING M4	11		
05	N32501	NUT, SPRING M5	4		
06	453053	COVER, SIDE REAR, LH.	1		
07	453054	COVER, SIDE REAR, RH.	1		
08	453055	BOTTOM PLATE	1		
09	GA552SC11	SCREW, TAPPING M4X16	6		
10	453057	SPLASH APRON	1		
11	S20817	BOLT, FLANGE M8X16	2		
12	402129	WASHER, RUBBER	2		
13	412409	SPACER	2		
14	412408	HANGER, HANDLE	1		
14A	412407	CARRIER, TAIL (OPTION)	1		
15	453056	HANDLE	1		
16	S72605	BOLT, HEX HEAD M6X16	3		
17	S72503	BOLT M5X16	4		
18	W99525	WASHER	4		
19	S20814	BOLT, FLANGE	2		

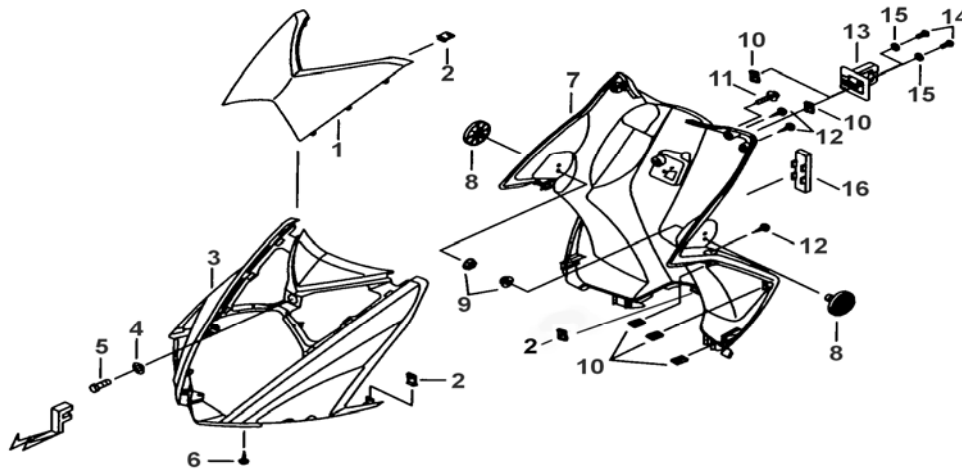

item_no	part_no	description	qty	amend	note1
01	454025	COVER, LEG SHIELD, FRONT	1		
02	GA552NT01	NUT, SPRING M4	5		
03	454026	LEG SHIELD, FRONT	1		
04	GA556WS02	WASHER	1		
05	GA510SC03	SCREW, HEX. HEAD M6X16	1		
06	S50401	SCREW TAPPING M4X12	2		
07	454029	COVER SET, LEG SHIELD	1		
08	GF5189903	REFLECTOR ASSY., SIDE	2		
09	GA554NT04	NUT, FLANGE M6xP1.0	2		
10	N32501	NUT, SPRING M5	8		
11	S25602	BOLT M6X16L	1		
12	GA552SC11	SCREW, TAPPING M4X16	6		
13	454028	HOOK LUGGAGE	1		
14	S72503	BOLT M5X16	2		
15	W99525	WASHER	2		
16	BH125PL04	COVER SET, LEG SHIELD, SMALL	1		

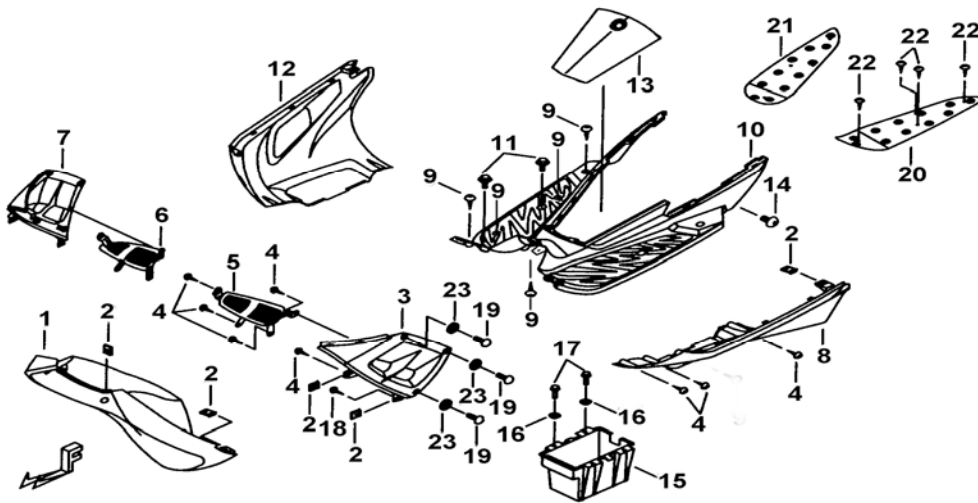

item_no	part_no	description	qty	amend	note1
01	455030	COVER, LOWER	1		
02	GA552NT01	NUT, SPRING M4	10		
03	455031	LEG SHIELD, SIDE LH.	1		
04	S50401	SCREW TAPPING M4X12	13		
05	455038	PLATE, AIR INLET, LH.	1		
06	455039	PLATE, AIR INLET, RH.	1		
07	455032	LEG SHIELD, SIDE RH.	1		
08	455046	LEG SHIELD, LOWER, LH.	1		
09	GA552SC11	SCREW, TAPPING M4X16	11		
10	455045	LEG SHIELD, REAR	1		
11	S25602	BOLT M6X16L	4		
12	455047	LEG SHIELD, LOWER, RH.	1		
13	455037	LID, BATTERY	1		
14	GA555SC02	SCREW, AN HEAD	2		
15	455036	BATTERY BOX	1		
16	GA556WS02	WASHER	4		
17	GA555SC05	BOLT, OUTLET M6X1.0X16L	4		
18	S50402	SCREW, TAPPING M4X10	2		
19	S72504	BOLT M5X20	6		
20	455040	MAT, LH.(AL)	1		
21	455041	MAT RH. (AL)	1		
22	S50407	SCREW, TAPPING M4X12	8		
23	W99525	WASHER	6		

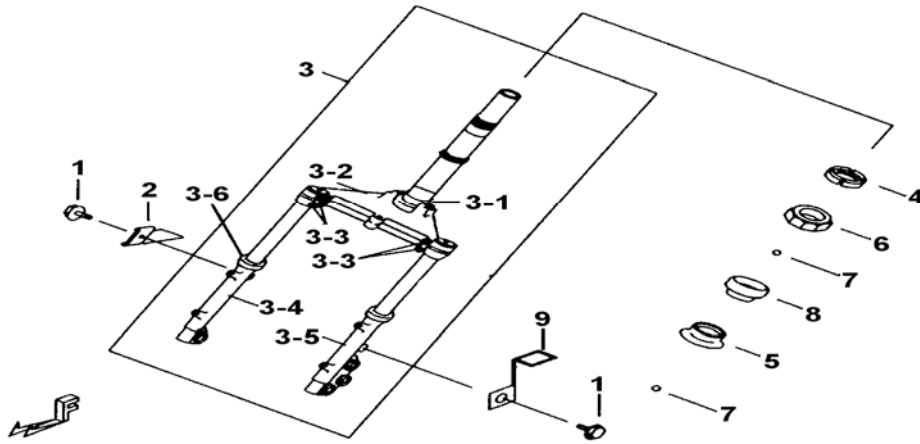

item_no	part_no	description	qty	amend	note1
01	GA556SC01	BOLT, FLANGE M6X1.0X12L	2		
02	GI527PS02	BRKT, CABLE, SPEEDOMETER	1		
03	412704	FORK COMP., FRONT	1		
03-1	GF527PS01	RACE, STEERING, OVTER, LOWER	1		
03-2	401970	CENTREL BAR ASSY.	1		
03-3	S20004	BOLT,FLANGE M10X30	4		
03-4	412705	FORK COMP., FRONT RH.	1		
03-5	412706	FORK COMP., FRONT LH.	1		
03-6	401876	SEAL, OIL	2		
04	GA556NT01	NUT, SLOTTED	1		
05	GF527PS02	RACE, STEERING INNER, LOWER	1		
06	GA556PS03	RACE, STEERING, INNER, UPPER	1		
07	GA556FE01	BALL	55		
08	GA556PS04	RACE, STEERING, INNER	1		
09	412716	BRKT, BRAKE HOSE	1		

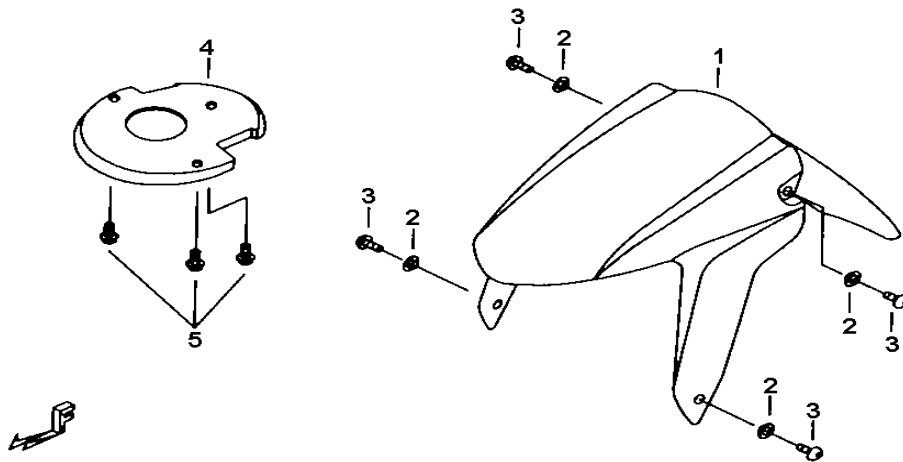

item_no	part_no	description	qty	amend	note1
01	456010	FRONT FENDER	1		
02	GA556WS02	WASHER	4		
03	GA555SC03	SCREW, AN HEAD M6X16	4		
04	456011	FENDER, FIXED, FRONT	1		
05	GA556SC01	BOLT, FLANGE M6X1.0X12L	3		



**29 FRONT WHEEL (FOR 13" RIM)**

**BM1**

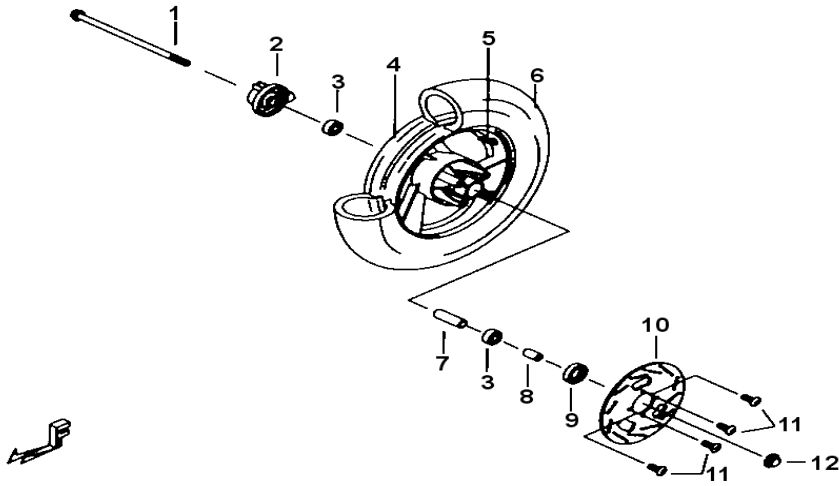

item_no	part_no	description	qty	amend	note1
01	GI529FE01	SHAFT, FRONT WHEEL 12X218	1		
02	GI5299901	GEAR COMP., SPEEDOMETER	1		
03	GI529BR01YT	BEARING 12X32X10	2		
04	412927YPA	RIM COMP., FRONT WHEEL 3.5-13 (AL)(BLACK)	1		
05	GF5299901	INLET COMP., AIR	1		
06	412900-S	TIRE 130/60-13	1		
07	401792	COLLAR SET	1		
08	GI529BS01	COLLAR	1		
09	GI529OS01	OIL SEAL 18X35X7	1		
10	410200Y	DISC, BRAKE 220mm	1		
11	GA558SC02	BOLT M8X1.25X15L	4		
12	N25201	NUT, SELFLOCK M12X1.25	1		

30

## HANDLE BAR

BM1

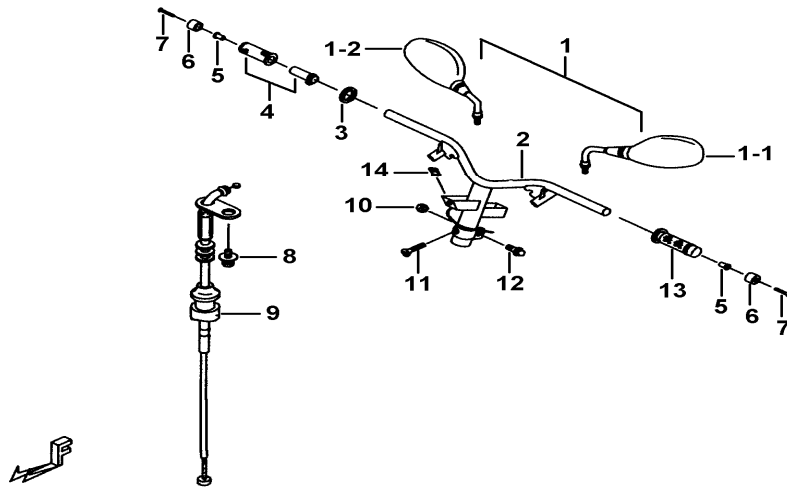

item_no	part_no	description	qty	amend	note1
01	413063	MIRROR ASSY., REAR VIEW	1		
01-1	414006	MIRROR, REAR VIEW, LH.	1		
01-2	414007	MIRROR, REAR VIEW, RH.	1		
02	413060	HANDLE BAR ASSY.	1		
03	413912	SEAL	1		
04	413031	GRIP ASSY., RH.	1		
05	401801	COLLAR	2		
06	401802	END, GRIP	2		
07	S35601	SCREW, FLAT HEAD	2		
08	GA557SC12	SCREW, PAN HEAD M5X10	1		
09	413068	CABLE, THROTTLE	1		
10	GA551NT01	NUT, SELFLOCK M10X1.0	1		
11	GA557SC02	SCREW, FLAT HEAD M8X35	1		
12	GA557SC01	BOLT, FLANGE M10X43	1		
13	401827	GRIP, LH.	1		
14	N32501	NUT, SPRING M5	1		

31

## HANDLE BAR COVER

BM1

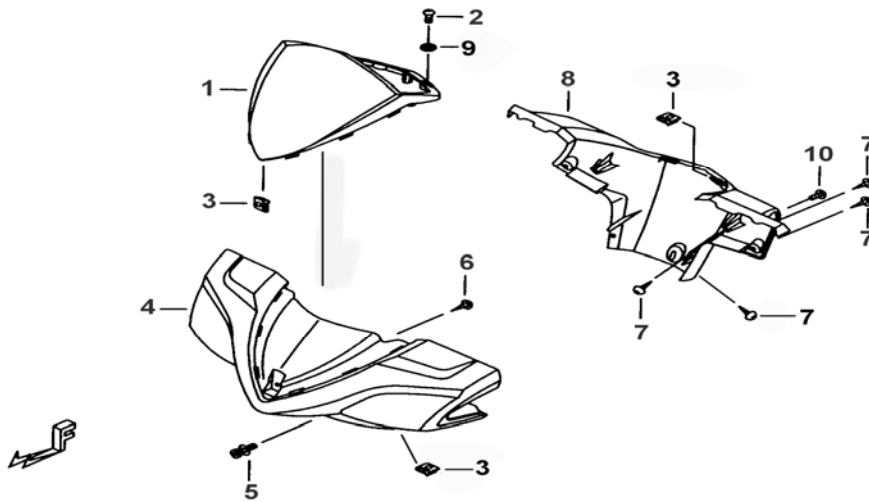

item_no	part_no	description	qty	amend	note1
01	457109	COVER, HANDLE BAR, UPPER	1		
02	S50406	SCREW, TAPPING M4X16	2		
03	GA552NT01	NUT, SPRING M4	5		
04	457127	COVER, HANDLE BAR, FRONT	1		
05	GA510SC10	SCREW, HEX. HEAD M5X20	1		
06	S50401	SCREW TAPPING M4X12	1		
07	GA552SC11	SCREW, TAPPING M4X16	8		
08	457128	COVER, HANDLE BAR, REAR	1		
09	W99525	WASHER	2		
10	GA552SC06	BOLT, OVAL HEAD 5X12	1		

**32 HANDLE BAR SWITCH**

**BM1**

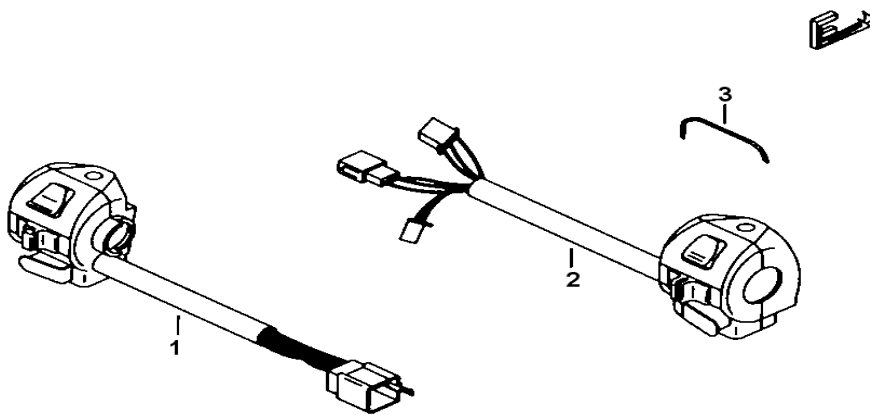

item_no	part_no	description	qty	amend	note1
01	413228	SWITCH ASSY., HANDLE, LH.	1		
02	413229	SWITCH ASSY., HANDLE, RH.	1		
03	413911	WASHER	1		

33

## REAR FENDER

BM1

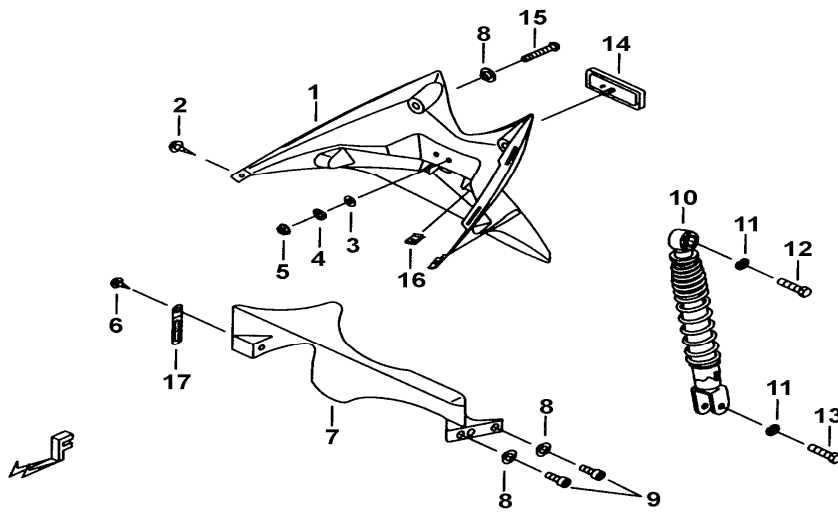

item_no	part_no	description	qty	amend	note1
01	458020	FENDER, REAR	1		
02	GA552SC11	SCREW, TAPPING M4X16	2		
03	GA552WS05	WASHER	1		
04	W10501	SPRING WASHER	1		
05	GA552NT05	NUT, FLANGE M5	1		
06	S50506	SCREW, TAPPING	1		
07	458004	SPLASH BOARD	1		
08	GA556WS02	WASHER	4		
09	S70609	SCREW, SOCKET HEAD M6x16	2		
10	410158	ABSORBER ASSY., SHOCK, REAR	1		
11	GA556WS06	WASHER, SPRING 10.2X3.7X2.5t	2		
12	GA556SC03	BOLT, HEX. HEAD M10X1.25X40L	1		
13	GA556SC04	BOLT, HEX. HEAD 10X34	1		
14	GF5189902	REFLECTOR ASSY., REAR	1		
15	S70618	BOLT M6X35	2		
16	GA552NT01	NUT, SPRING M4	2		
17	GA501SR01	CLAMP	1		

**34 REAR WHEEL (FOR 13" RIM)**

**BM1**

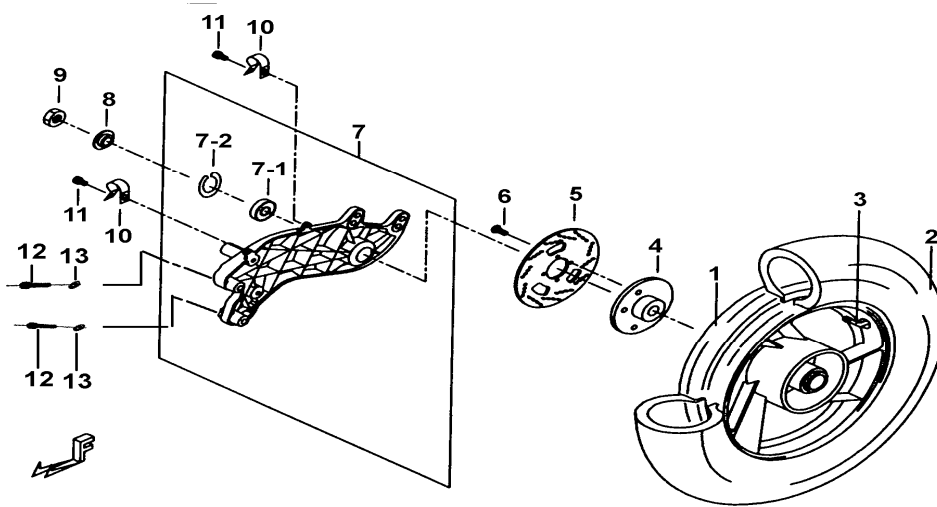

item_no	part_no	description	qty	amend	note1
01	413400YPA	RIM COMP., REAR WHEEL 3.5-13 (AL)(BLACK)	1		
02	412900-S	TIRE 130/60-13	1		
03	GF5299901	INLET COMP., AIR	1		
04	413416	BASE, BRAKE	1		
05	410200Y	DISC, BRAKE 220mm	1		
06	S72001	SCREW, SOCKET	4		
07	413415	REAR FORK ASSY.	1		
07-1	412918	BEARING	1		
07-2	R01001	RETAINER RING, C TYPE	1		
08	412921	COLLAR	1		
09	GA558NT03	NUT, SELFLOCK M16X14	1		
10	413417	CLAMP	2		
11	S20603	BOLT, FLANGE M6X12	2		
12	S70003	SCREW, HEX. SCCKET	2		
13	GA556WS06	WASHER, SPRING 10.2X3.7X2.5t	2		

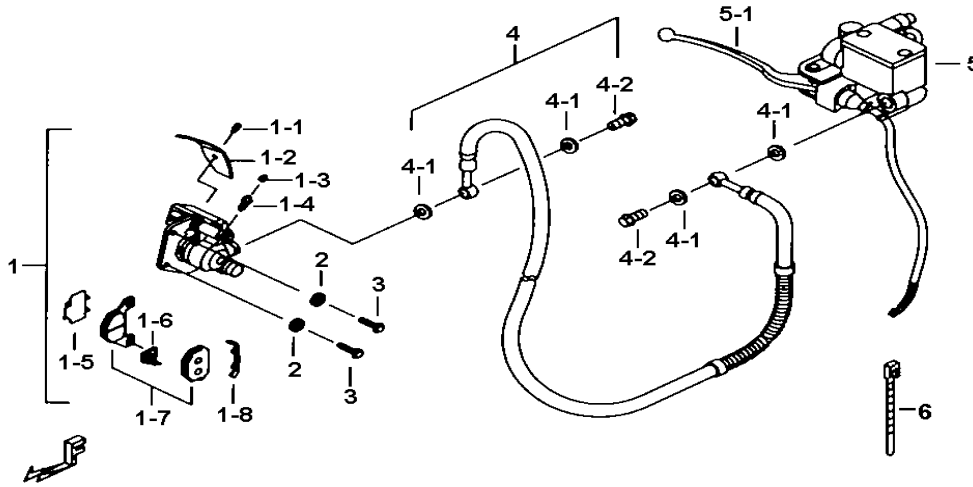

item_no	part_no	description	qty	amend	note1
01	413602RD	CALIPER(RED)	1		
01-1	S43501	BOLT	1		
01-2	413607	DUST COVER	1		
01-3	GA559RB01	CAP, GUARD	1		
01-4	GA559SC01	BOLT, FLANGE	1		
01-5	413608	PLATE, WASHER	1		
01-6	413609	SPRING PLATE	1		
01-7	413610	PAD ASSY.	1		
01-8	413611	SPRING PLATE	1		
02	W99805	WASHER	2		
03	GA558SC03	BOLT, HEX. HEAD	2		
04	413627	HOSE ASSY., FRONT BRAKE	1		
04-1	GA559WS04	WASHER, 10.2X15X1.2t	4		
04-2	S21001	OIL BOLT M10X1.25X22L	2		
05	413625	MASTER CYLINDER	1		
05-1	401020	LEVER, HANDLE BAR	1		
06	GA510SR01	CLAMP	1		

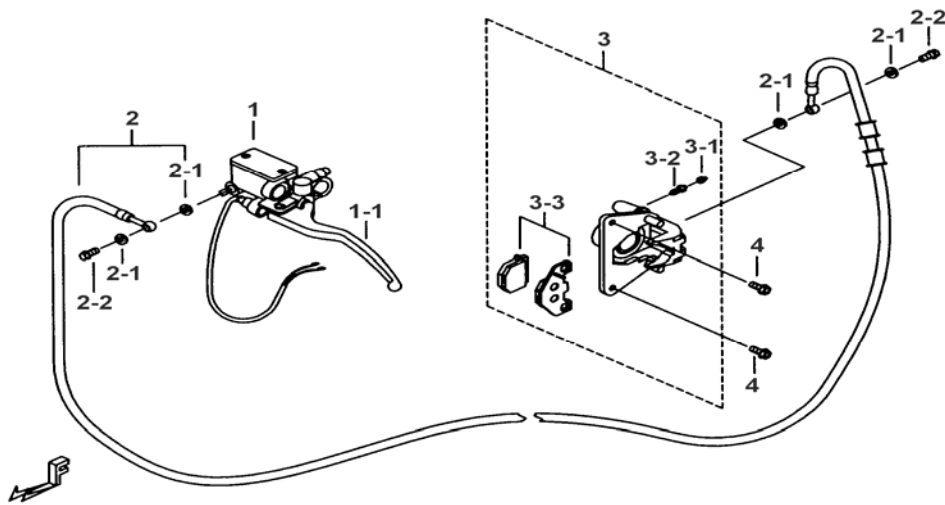

item_no	part_no	description	qty	amend	note1
01	413502	MASTER CYLINDER	1		
01-1	401020	LEVER, HANDLE BAR	1		
02	413501	HOSE ASSY., REAR BRAKE	1		
02-1	GA559WS04	WASHER, 10.2X15X1.2t	4		
02-2	S21001	OIL BOLT M10X1.25X22L	2		
03	413500	CALIPER(REAR)(RED)	1		
03-1	GA559RB01	CAP, GUARD	1		
03-2	GA559SC01	BOLT, FLANGE	1		
03-3	GF5359902	PAD ASSY.	1		
04	S20814	BOLT, FLANGE	2		



37

LABELS

BM1

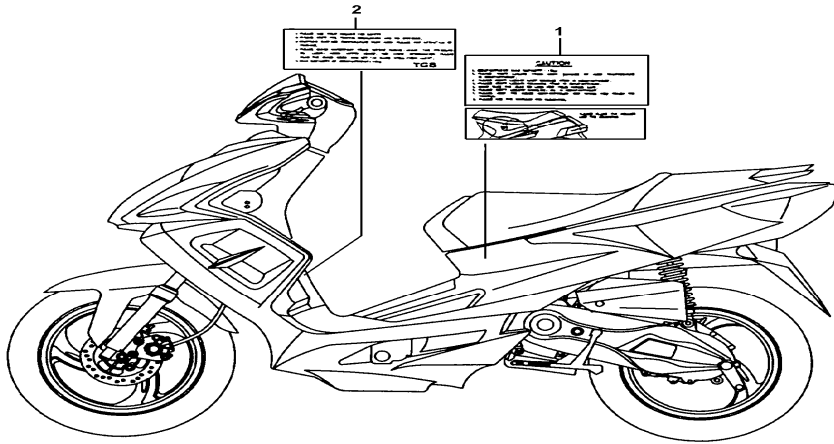

item_no	part_no	description	qty	amend	note1
01	GF523TH04	LABEL, LUGGAGE BOX	1		
02	GF525TH12	LABEL, WARNING	1		

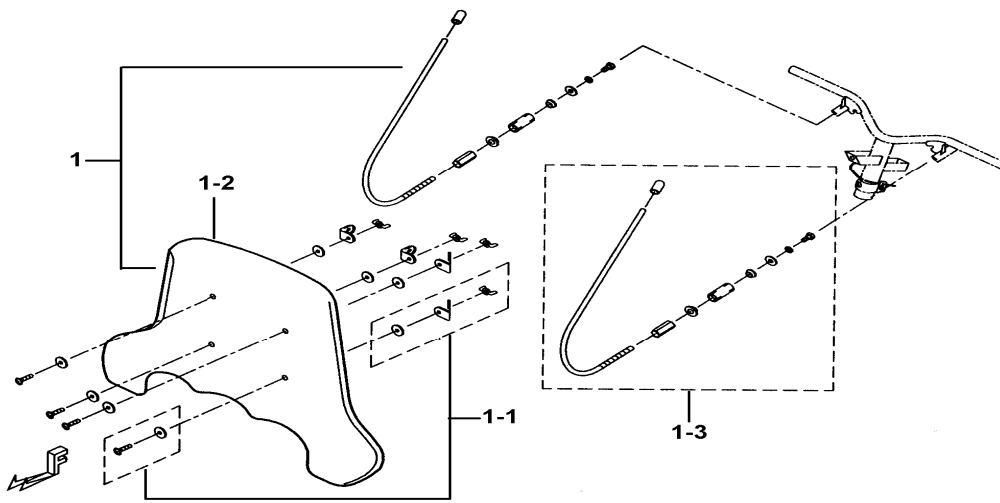

item_no	part_no	description	qty	amend	note1
01	413997	WIND-SHIELD ASSY.	1		
01-1	457046	BLOT SET	4		
01-2	457029	WIND-SHIELD	1		
01-3	413061A	FIXED ROD SET	2		