

**SKYTEAM**

ST 50-6/ST110-6

OPERATION INSTRUCTION

**SKY TEAM CORPORATION LTD.**

1104 CARNIVAL COMMERCIAL BLDG.

18 JAVA ROAD NORTH POINT HONGKONG

TEL:00852 25089428

FAX:00852 25089478

EMAIL:SKYTEAM\_HK@HOTMAIL.COM

HTTP://WWW.SKYTEAM.NET.CN

WWW.SKYTEAM.CN



**SKYTEAM** MOTORCYCLE

## FOREWORD

Respectable consumer:

Thank you for purchasing this Skyteam motorcycle and welcome to the family of Skyteam motorcycle riders.

Skyteam motorcycle, famous for its reasonable design, advanced process and beautiful appearance, are sold well at home and abroad, and are highly appraised by old and new customers.

Skyteam motorcycle, as an ideal riding tool instead of walk and a light-duty transportation tool, will provide happiness for your work.

The proper operation and simple maintenance that your motorcycle requires is outlined in this manual, read carefully this manual before riding the motorcycle, it will provide you with efficient help for operating and maintaining your Skyteam motorcycle. To ensure your motorcycle in good condition and safe riding, use the genuine Skyteam accessories. If you have any questions, or if you ever need a special service or repairs, remember that your Skyteam dealer knows your motorcycle best and is dedicated to your complete satisfaction.

Welcome to your opinions and suggestions for improving Skyteam motorcycle, wish our friendship forever and ever.

ALL INFORMATION IN THIS MANUAL IS SUBJECT TO CHANGES  
WITHOUT PRIOR NOTICE FROM THE MANUFACTURER

## TABLE OF CONTENTS

Important precautions	2	Starting the engine	22
Consumer information	3	Starting off	23
Component locations	9	Drive on slope	24
Controls	12	Braking and parking	24
Key	12	Checks and maintenance	25
Ignition switch	12	Periodic maintenance chart	27
Instrument panel	12	Lubrication	29
Left handlebar	13	Battery and fuse	29
Right handlebar	14	Air cleaner	30
Seat lock	15	Spark plug	32
Fuel tank cap	15	Transmission oil	32
Fuel cock	15	Carburetor	33
Kick starter lever	16	Throttle cable adjustment	34
Rear brake pedal	16	Drive chain	35
Gearshift lever	17	Brakes	37
Steering lock	17	Rear brake switch	40
Helmet holder	18	Tires	40
Fuel and engine oil recommendation	19	Change of bulb	42
Running-in	19	Troubleshooting	42
Inspection before riding	21	Specifications	42
Riding tips	22		

## IMPORTANT PRECAUTIONS

### BREAK-IN INFORMATION FOR YOUR MOTORCYCLE

The first 1,600km is the most important in the life of your motorcycle. Proper running - in operation during this time will help ensure maximum life and performance of your new motorcycle.

Motorcycle reliability and performance depend on special care and restraint exercised during running-in period. It is important that you avoid operating the engine in the manner which could expose the engine parts to excessive heat.

Please refer to the "running-in" section for specific running - in recommendation.

Please read this manual and following its instructions carefully.

To emphasize special information, the words WARNING, CAUTION and NOTE carry special meaning and should be carefully reviewed.

**WARNING:** The personal safety of the rider may be involved, disregarding this information could result in injury to the rider.

**CAUTION:** These instructions point out special service procedures or precautions that must be followed to avoid damaging the machine.

**NOTE:** These provide special information to make maintenance easier or important instructions clearer.

## CONSUMER INFORMATION

### ACCESSORY INSTALLATION AND SAFETY PRECAUTION TIPS

There are great varieties of accessories available to Skyteam owners. The addition of unsuitable accessories can lead to unsafe operation conditions. For proper installation of accessories, we have laid down some principles which will help you for the correct choice and installation of accessories.

(1) If you want to install an accessory which will result in an extra weight or an aerodynamic effect to your motorcycle, try to install it as low as possible and as close as possible to the center of gravity of your motorcycle. Check carefully the holder for installing accessories to make sure of its firmness. The infirm installation will lead to unstable and dangerous conditions due to weight deviation.

(2) Check the net clearance and turning angle to make

sure that they are adequate. The improper load, which may occur after installing accessories, will very likely lower their safety factors. Checks should also be made that this improper load will not hinder the idling, tuning and other control actions.

(3) Fixing the accessories on handlebars or front fork will result in unstable operation. This extra weight will reduce the maneuverability of your motorcycle during turning operations, meanwhile, this extra weight will also cause unstable condition due to vibration at the front end. Therefore, fixing accessories on handlebars or front fork should be minimized.

(4) Things like wind glass, windshield, waist support, bags across seat and suitcases all have an aerodynamic effect on the stability of your motorcycle, when there is a side wind or large vehicles passing by. The improper installation or bad design of accessories will

affect your driving safety. Therefore, you should be careful for the choice and installation of accessories. (5) Certain accessories displace the rider from his normal riding position. This will not only limit the freedom of movement of the rider, but also his control ability.

(6) Extra electrical accessories may overload the existing electrical system. Severe overloads may damage the wiring harness or create a dangerous situation due to the loss of electrical power during the operation of the motorcycle.

When carrying a load on the motorcycle, mount it as low as possible and as close as possible to the motorcycle. An improperly mounted load can create a high center of gravity which is very dangerous and make the motorcycle difficult to handle. The size of a load can affect the aerodynamics and the handling of the motorcycle. Balance the load between the left

and right side of the motorcycle and fasten it firmly.

**SAFE RIDING RECOMMENDATIONS FOR MOTORCYCLE RIDERS**

Motorcycle riding is a great joy and an exciting sport. Motorcycle riding also requires that some extra precautions be taken to ensure the safety of the rider. These precautions are:

**WEAR A HELMET**

Motorcycle safety equipment starts with a quality safety helmet. One of the most serious injuries that can happen is a head injury. Always wear a properly approved helmet. You should also wear suitable eye protection.

**RIDING APPAREL**

Tight, fancy clothing can be uncomfortable and unsafe when riding your motorcycle. Choose good quality motorcycle riding apparel when riding your motorcycle.

**CHECKS BEFORE RIDING**

Review thoroughly the instructions in the "CHECK BEFORE RIDING" section of this manual. Do not forget to perform all the safety checks to ensure the safety of the rider.

**FAMILIARIZE YOURSELF WITH THE MOTORCYCLE**

Your riding skill and your mechanical knowledge form the safe riding practices. We suggest that you practice riding your motorcycle in a non-traffic situation without obstacles until you are thoroughly familiar with your machine and its controls. Remember that practice makes perfect.

**KNOW YOUR SAFETY SPEED LIMITS**

Ride within the boundaries of your own skill at all times. Knowing these limits and staying within them will help you to avoid accidents.

**BE EXTRA SAFETY CONSCIOUS ON BAD WEATHER DAYS**

Riding on bad weather days, especially wet ones, requires extra caution. Braking distance doubles on a rainy day. Stay off the painted surface marks, Manhole covers and greasy appearing areas as they can be especially slippery. Use extreme caution at railway crossings and on metal grating and bridges. Whenever in doubt about road condition. SLOW DOWN!

**AUTOMOBILE/MOTORCYCLE ACCIDENTS PREVENTION**

Many automobile/motorcycle accidents happen because the automobile driver does not "SEE" the motorcyclist.

Make yourself conspicuous to help avoid the accident that wasn't your fault:

Wear bright or reflective clothing.

Don't ride in another motorist's "blind spot".

Signal before you make a turn or lane change. Your size and maneuverability can surprise other motorists.

## MODIFICATION

Modification of the motorcycle, or removal of original equipment may render the vehicle unsafe or illegal. Obey the local regulations for available equipment.

## STEERING STEM REMOVAL

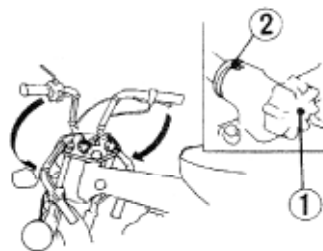

In order to reduce the occupied space, the motorcycle steering stem can be removed or bent. Turn off the steering stem tightening wheel (1), making the locating boss leave the groove, then bend the lower steering stem as per the direction shown in the figure, making the boss coincide with the groove and screwing up the steering stem tightening wheel. On the contrary, the steering stem can be returned to its original position.

### WARNING

**After the steering stem is located, make sure to screw up the steering stem tightening wheel.**

## SERIAL NUMBER LOCATION

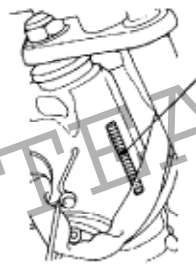

①Frame No.

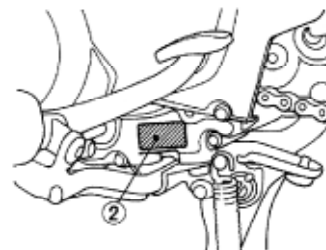

②Engine No.

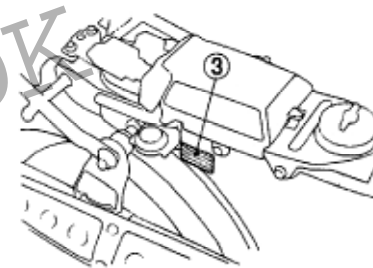

③Motorcycle nameplate

The frame and/or engine serial numbers are used to register the motorcycle. They are also used to assist your dealer when ordering parts or referring to special service information.

The frame number (1) is stamped on the steering stem head right surface. The engine serial number is stamped on the left side of crankshaft and the motorcycle nameplate is stamped on the right side center of frame.

Please write down the numbers here for your reference.

Frame No.

Engine No.

COMPONENT LOCATION

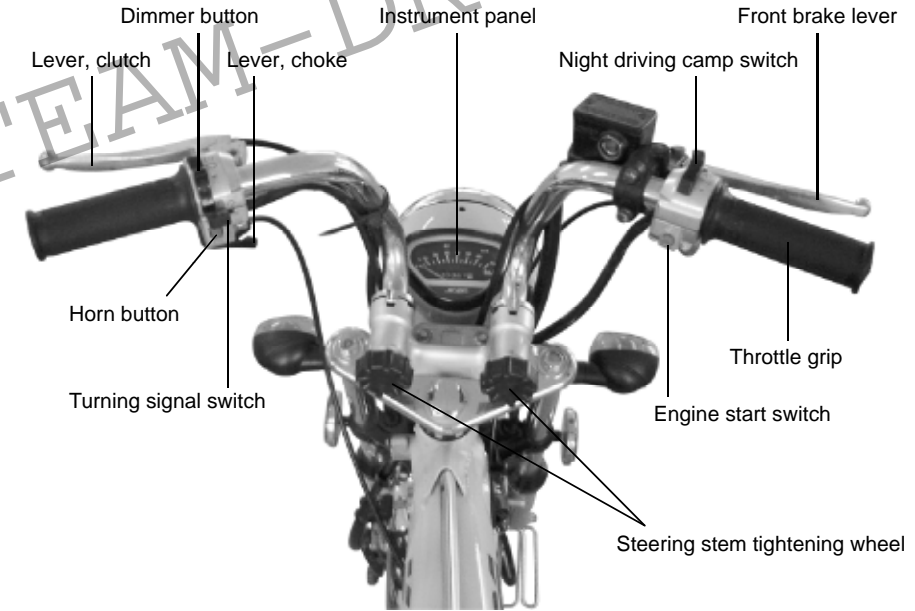

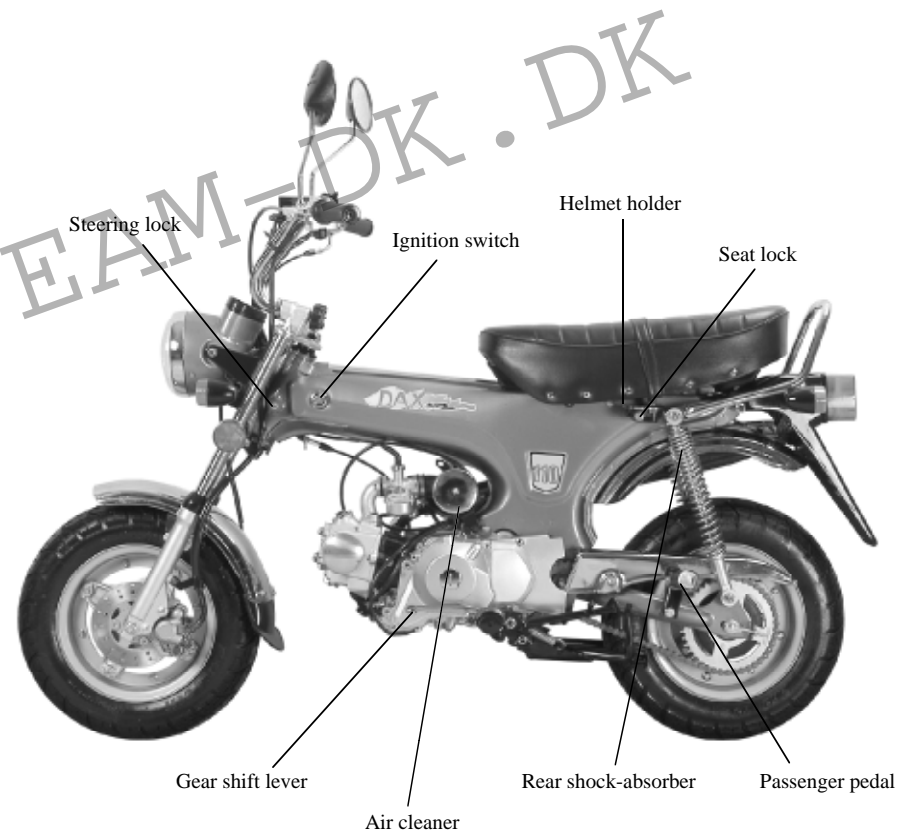
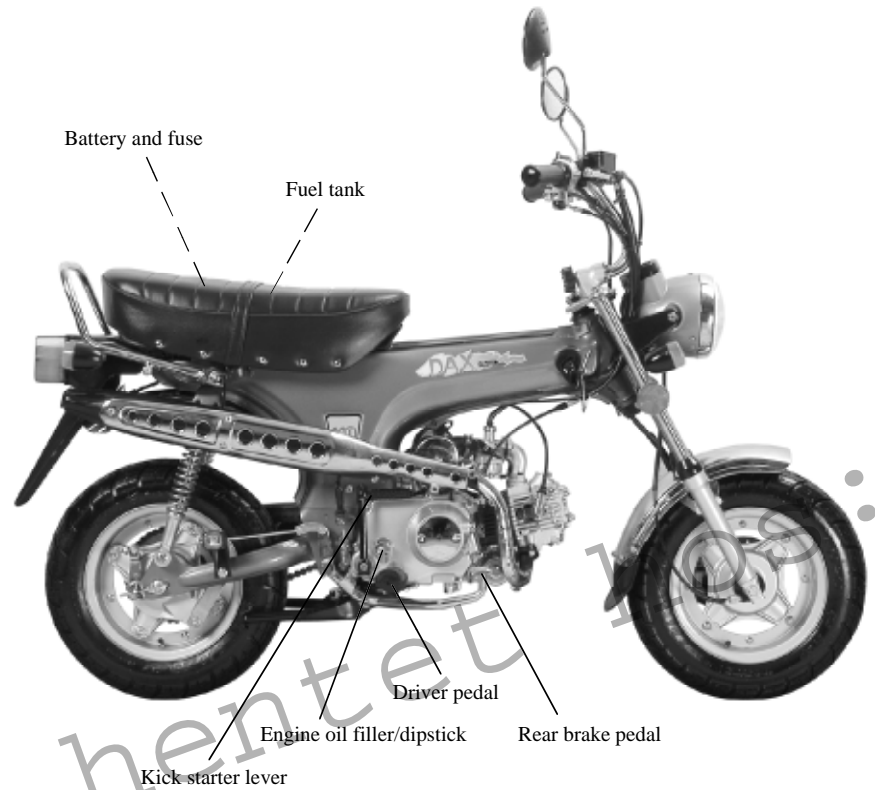



## CONTROLS

### KEY

This motorcycle comes equipped with a pair of identical ignition keys. Keep the spare key in a safe place.

### IGNITION SWITCH

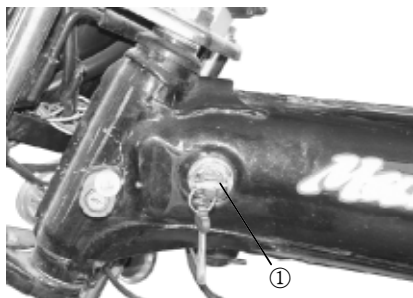

(1) ignition switch

There are two positions for ignition switch:

#### "OFF" POSITION

All electrical circuit is disconnected.

#### "ON" POSITION

All electrical circuits are connected and the engine

can be started.

### INSTRUMENT PANEL

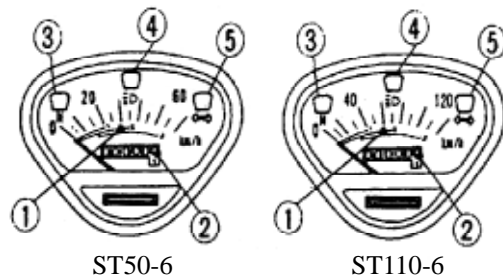

#### SPEEDOMETER(1)

The speedometer indicates the road speed in kilometers per hour.

#### ODOMETER(2)

The odometer registers the total distance that motorcycle has been ridden.

#### NEUTRAL INDICATOR LIGHT(3)

The green neutral indicator light comes on when the transmission is in neutral. When the transmission is engaged in other gear, this light goes out.

#### HIGH BEAM INDICATOR LIGHT(4)

This indicator light comes on when the headlight high beam is turned on.

#### LEFT/RIGHT TURNING SIGNAL INDICATOR LIGHT(5)

This indicator light comes on when the direction signal turns left or right.

### LEFT HANDLEBAR

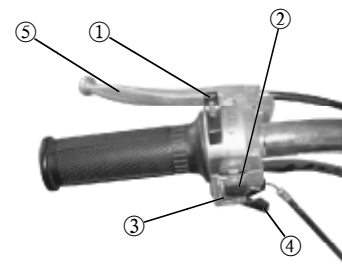

#### DIMMER SWITCH(1)

Turning the right handlebar in "☉" position, in this time, the front and rear lightening lamps come on to give the warning. Shifting the dimmer switch into "☉" position, the headlamp high beam indicator light comes on. Shifting the dimmer switch into "•" position, the front and rear position indicator lights come on.

#### TURN SIGNAL SWITCH(2)

Turning the switch into "◁" position, the left turn signal indicator will flash intermittently, shifting the switch into "▷" position, the right turn signal indicator will flash intermittently, while in central position, the left and right turn signal indicator lamps do not work altogether.

### WARNING

**Always use the turn signal when you intend to change lanes or make a turn. Always be sure to push turn signal switch to central position after completing the turn or lane change.**

### HORN BUTTON(3)"🔊"

Press the button to operate the horn.

### CHOKE LEVER(4)"🔧"

When starting a cold engine, use the choke lever.

### CLUTCH LEVER(5)

When starting engine or shifting gear, the clutch lever is used to disconnect the driving of gear wheel.

### RIGHT HANDLEBAR

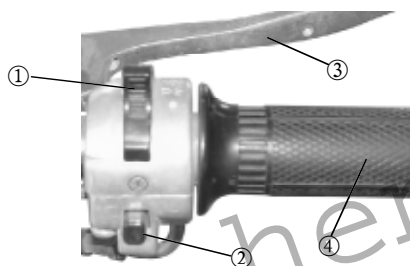

### NIGHT DRIVING LAMP SWITCH(1)

"🔦": When the engine is in working condition, the headlamp, instrument lightening lamp and tail lamp come on simultaneously.

"🚗": When the engine runs or goes out, the headlamp and tail lamp can be lighted up to give a warning.

"•": The headlamp, position indicator lamp, instrument lighting lamp and tail lamp do not come on.

### ELECTRICAL START BUTTON(2)"🔌"

"🔌": Push down the electrical start button to start the engine.

### FRONT BRAKE LEVER(3)

Squeezing the front brake lever will apply the front brake.

### WARNING

**Using only the front or rear brake is dangerous while driving in high speed. Apply the brakes lightly and with great care.**

### THROTTLE GRIP(4)

The throttle grip is used to control the engine speed. Twist the throttle grip toward yourself to increase the engine speed. Turn it away from yourself to decrease the engine speed.

### SEAT LOCK

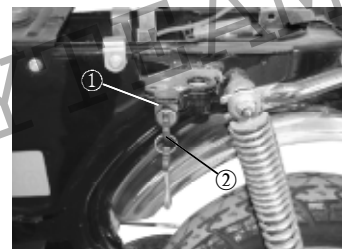

To unlock the seat, insert the ignition key (2) into the lock (1) and turn it counterclockwise.

### FUEL TANK CAP

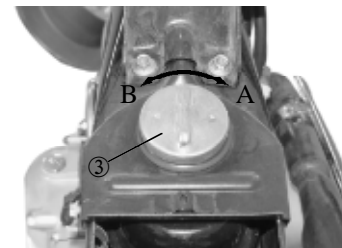

To open the fuel tank cap, open the seat and turn the cap (3) along the lines of "A" to "ON" position. To close the fuel tank cap, turn it along the lines of "B" to "OFF" position.

### WARNING

**Do not overfill the fuel tank. Do not fill the fuel tank above the bottom of the filler tube as shown in the illustration.**

**When refueling, always shut the engine off and turn the ignition key to the "OFF" position. Never refuel near an open flame.**

**Take care not to spill gasoline during refueling.**

### FUEL COCK

The type of motorcycle is equipped with manual acting fuel lever. There are three positions: "ON", "RESERVE" and "OFF".

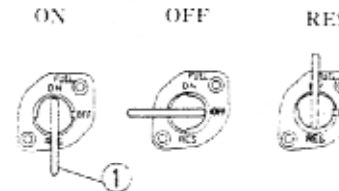

## "ON"

Normal position while operating the motorcycle. At this time, the gasoline flows through the fuel lever to carburetor.

## "RES"

If the fuel level in the fuel tank is too low, turn the lever to the "RESERVE" position to use the reserved fuel.

## "OFF"

After the engine stops for a few minutes, put the fuel lever to "OFF" position.

### WARNING

When putting the fuel lever to "ON" or "RES" position, it is possible to cause carburetor fuel overflow and fuel flows into the engine. When starting engine, it is possible to cause serious mechanical damage with fuel in the engine.

Therefore, after shut off the engine, it is required to turn the fuel cock into "OFF" position.

### NOTE

When the fuel tank supply is in the "RES" position, refilling the fuel in nearby station. After refilling fuel, turning the fuel lever to "ON" or "OFF" position.

### KICK STARTER LEVER

The kick starter lever is located on right side of the engine.

### WARNING

After starting the engine, check if the kick starter lever is returned to its normal position.

### REAR BRAKE PEDAL

Pressing the rear brake pedal will apply the rear brake. When operating rear brake, the rear brake indicator light turns on.

### GEARSHIFT LEVER



Gearshift lever(1) is connected with ratchet. After choosing one gear, the gearshift lever is returned to its original position for choosing another gear. The gear shift pattern is international type, i.e. the first gear down; the second, third and forth gear up.

### CAUTION

When the gearshift is in neutral gear position, the blue indicator(neutral gear indicator) will light.

Before shifting gear down, reduce the motorcycle speed, and when shifting gear down before the connection of clutch, increase the engine speed to avoid over wear of rear tire and driving elements.

### STEERING LOCK

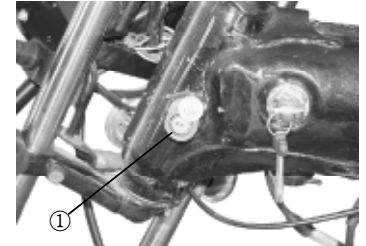

To lock the steering, turn the handlebar all the way to the right, insert the ignition key in the steering lock (1) and turn it clockwise. When stopping the motorcycle, lock the steering lock.

#### WARNING

**Never attempt to move the motorcycle when the steering lock is locked, or you may lose balance.**

#### HELMET HOLDER

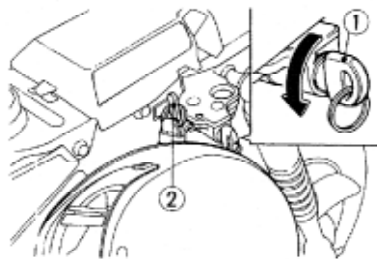

The use method of helmet holder is: Insert the ignition key (1) into the seat lock, and turn it clockwise to unlock, then hang your helmet on the hook (2) at

the seat hinge and lower the seat to lock. To remove a helmet, unlock the seat. Lift the helmet off the holder and lower the seat, making sure it is securely locked before riding.

#### WARNING

**Do not operate the motorcycle with a helmet attached to the holder; the helmet may interfere with the safe operation of the motorcycle.**

## FUEL AND ENGINE OIL RECOMMENDATION

### FUEL

Use SH0041-93 unleaded type gasoline, this gasoline should be at least 90 octanes.

By using recommended unleaded type gasoline, it can prolong the spark plug, exhausting system parts and motorcycle service life.

### ENGINE OIL

The engine oil used in this motorcycle conform to Chinese national standard GB11121-95 and ANS SAEJ183E80. Please use a good quality 15W/40 SF/CD GB11121-95 engine oil. Skyteam motorcycle special engine oil, is recommended to be used. The ordinary engine oil, vegetable oil, or castor-based racing oil are not recommended.

Select the recommended engine oil with different

precision class and brand according to the different areas and temperatures.

The engine oil shown in the following chart may be used according to the average temperature in your riding area.

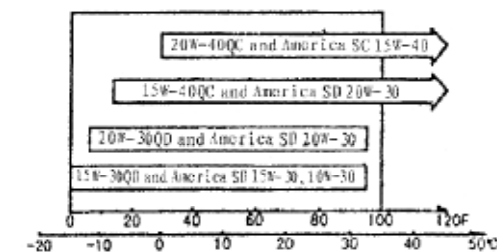

### RUNNING-IN

The forward explains how important the proper running-in is to achieve maximum life and performance from your new Skyteam motorcycle. The following guidelines explain proper running-in procedures.

## MAXIMUM SPEED

This table shows the maximum speed in running-in period.

Initial 160km	Less than 30km/h
Up to 800km	Less than 33km/h
Up to 1600km	Less than 40km/h

## VARY THE ENGINE SPEED

The engine speed should be varied and not held at a constant speed. This allows all the parts in the engine to be loaded and unloaded. The parts will cool down when they are unloaded. This is conductible for matching between the engine parts.

During running- in period, it is necessary to apply a reasonable stress on all the engine parts to ensure the best matching between them. The stress or load applied to engine parts should be adequate, not excessive.

## AVOID CONSTANT LOW SPEED

Operating the engine at constant low speed (light load) can cause parts to graze and not seat in. Allow the engine to accelerate freely through the gears provided that the recommended maximum limit is not exceeded. Do not, however, use full throttle for the first 1600km.

## ALLOW THE ENGINE OIL TO CIRCULATE BEFORE RIDING

Allow sufficient idling time after warm or cold engine start up before applying load or reviving the engine. This allows time for the lubricating oil to reach all critical engine components.

## PERFORM YOUR FIRST, AND THE MOST CRITICAL, SERVICE

The first 1,000km service is the most important one that your motorcycle will receive. During running-in, all engine components will have worn in and all the other parts will have seated in. At this time

all adjustment should be made, all fasteners should be tightened and the dirty oil be replaced.

Timely performance of the first 1,000km service will ensure optimum service life and performance of the engine.

### CAUTION

**The first 1,000km service should be performed as outlined in the maintenance schedule section of this owner's manual. Pay particular attention to the caution and warning in maintenance schedule section.**

## INSPECTION BEFORE RIDING

Before riding the motorcycle. Be sure to check the following items. Never underestimate the importance of these checks and perform all of them before riding the motorcycle.

WHAT TO CHECK	CHECK FOR:
<b>STEERING</b>	(1)Smoothness (2)No restriction of movement (3)No play or looseness
<b>BRAKES</b>	(1)Correct pedal and lever play (2)No dragging (3)Brake shoes to be within the wear limit
<b>TYRES</b>	(1)Correct pressure (2)Adequate tread depth (3)No crack or cuts
<b>FUEL</b>	Enough fuel for the planned distance
<b>LIGHTING</b>	Operation of all lights and indicator lights-headlamp, tail lamp, brake lamp, instrument lighting lamp, turning signal lamp
<b>HORN</b>	Correct function
<b>ENGINE OIL</b>	Enough amount of oil
<b>THROTTLE</b>	(1)Correct play in the throttle cable (2)Smooth operation and positive return of the throttle grip to the closed position
<b>DRIVE CHAIN</b>	(1)Correct play in clutch (2)Smooth operation

## RIDING TIPS

### WARNING

- (1) If it is the first time that you have ridden a motorcycle of this type, we suggest that you practice on a non-public road to become thoroughly familiar with controls and operation of the motorcycle.
- (2) One-hand riding is extremely dangerous. Keep both hands firmly on the handlebars and feet securely on the footrests. Under no circumstances should both hands be removed from the handlebars.
- (3) Don't brake hard in the midst of cornering. Slow down to a safe speed before negotiating a corner.
- (4) When the road surface is wet or slippery, there is a reduction in tire traction. You should reduce speed when ever these conditions exists as braking and cornering ability are reduced.
- (5) At side winds which may be experienced at the exits of tunnels, when passing by the cut of hill, or when being overtaken by larger vehicles, you should reduce speed and ride alertly.
- (6) Obey the speed limit and traffic regulations at all times.

## STARTING THE ENGINE

Check the fuel lever to make sure that is at "ON" position, insert the ignition switch and turn it clockwise to the "ON" position.

When the transmission is in neural, neutral indicator will light.

### WARNING

**Always start the engine with the transmission in neutral.**

## WHEN THE ENGINE IS COLD

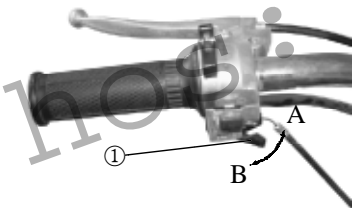

Turn the choke lever from "A" position to "B" position, push the electric start button or depress

the kick starter lever to start the engine. Immediately after the engine starts, let the engine run until the engine sufficiently warms up, then return the choke lever to its original position. When the engine runs smoothly and the choke lever is in its disengaged position, the engine is warmed up sufficiently. The more cool is the temperature, the more time is needed for warming up the engine.

## WHEN THE ENGINE IS WARM

Open the throttle by 1/8 to 1/4. push the electric starter button or depress the kick starter lever. The operation of the carburetor choke system is usually not necessary when the engine is warm(the choke lever should be at "A" position).

### NOTE

**If 2~3 times operation can not start the engine, open the throttle grip 1/8 to 1/4 turn, then restart the engine.**

**A motorcycle not used for long-time or poor vaporized fuel may cause difficult starting, in this time, don't turn the throttle grip, but repeatedly start the engine.**

### WARNING

**Do not run the engine indoor where there is little or no ventilation available. Carbon monoxide fumes are extremely poisonous. Never leave the motorcycle running while unattended, even for a moment.**

### CAUTION

**Do not let engine run excessively without riding, or it will overheat and may damage internal engine components.**

## STARTING OFF

Automatic clutch

Stamp down the shifting lever, the first gear is engaged. Twist the throttle lever toward yourself, at the same time, smoothly and slowly loosen the clutch lever. Due to engagement of clutch, the motorcycle moves forward.

For shifting to next higher gear, slowly increase the speed, then shut off the throttle. Turn shifting lever to next higher gear and open the throttle, the highest gear can be engaged by following these steps.

### Manual clutch

Keeping the engine running at idle speed, pulling in the clutch lever and wait a minute, stamp down the shifting lever with left foot toe to engage the first gear. Slowly open the throttle and lightly leave the clutch lever, the gear is engaged and the motorcycle moves forward.

For shifting to next higher gear, firstly open the throttle, then shut off the throttle, at same time leave the clutch, stamp down the shifting lever to 2nd gear. Then lightly loosen clutch lever to let the gear engaged, then slowly open the throttle.

#### WARNING

**Before starting off you must put the side stand back in its position entirely. Don't let it hang.**

### DRIVING ON SLOPE

When climbing and feeling that impetus is not enough, shift gear down to let the engine run in its power range.

Shifting gear should be performed quickly to avoid the loss of impetus.

When driving on downhill, shift gear down to facilitate the brake.

Don't let the engine run too quickly.

### BRAKING AND PARKING

Twist the throttle grip away from yourself to close the throttle completely.

Apply the front and rear brakes evenly and at the same time.

#### NOTE

**An inexperienced driver often uses only the rear brake, this will accelerate the brake system wear and prolong the brake distance.**

#### WARNING

**Using only the front or rear brake is dangerous and can cause skidding and loss of control. Apply and brakes lightly and with great care on a wet or slippery surface. Brakes hard on glossy or rugged and rough road is very dangerous.**

#### WARNING

**The more high speed of vehicle is, the more long distance of braking needs. Be sure of the safe distance between front vehicle or object and yourself.**

Pulling in the clutch lever and letting the linkage gear in the transmission disconnected, reduce the motorcycle speed and shift the gear into neutral, until full brake.

Before stopping the motorcycle, observe the neutral indicator light to distinguish if it is in neutral gear.

Place the motorcycle on a firm and level ground.

Before starting the engine, remember to shift the gear into neutral.

Turn the ignition switch to the "OFF" position to stop the engine.

Remove the ignition key from the switch.

Turn the fuel cock to the "OFF" position.

Lock the steering for security.

### CHECKS AND MAINTENANCE

The chart below indicates the intervals between periodic service in kilometers and months. As the end of each interval, be sure to check, inspect, lubricate and service as instructed. If your motorcycle is used under high stress conditions such as continuous full throttle operation, or is operated in a dusty climate, certain services should be performed more often to ensure reliability of the motorcycle section.

Steering components, suspension and wheel components are key items and require very special and careful servicing. For maximum safety we suggest that by your authorized Skyteam dealer or qualified service personnel.

**CAUTION**

**Proper running-in maintenance (1,000km) is a mandatory item for making certain that our motorcycle is reliable and gives full performance at all times. Be sure that this periodic maintenance is performed thoroughly and in accordance with the instructions in this manual.**

**PERIODIC MAINTENANCE CHART**

Item \ Period	Initial 1000km	1600km	3000km	5000km	Afterwards every 2000-3000km
* Engine fixing bolts and nuts	C	C	C	C	C
* Inlet and outlet valve clearances (cold state)	C	C	C	A	C and A
Transmitting chain tension	C	C	A	A	C and A
Carburetor	C	CL	C	C	C and A
Air cleaner	---	---	CL	---	CL
Lub oil in gear box	R	R	R	R	R
Lub oil filter gauze	C	C	C	C	C
Spark plug	C	C	C	C	C
Throttle grip and cable	C	---	C	C	C
* Brakes (front, rear)	C	C	C	C	C
Tire pressure	C	---	C	C	C
Speedometer soft spindle	C	---	---	C	C
* Front and rear wheel center bearing	C	---	---	O	C
Fuel tank cock	C	---	C	C	C
* Steering	C	C	C	C	C
* Fuel lines	C	C	C	C	C
* * All parts for fixing	C	C	C	C	C



**KEY: C=Check, CL=Clean, A=Adjustment, R=Replace, O=Oil**

**NOTES:**

- (1) This chart is for reference of periodic maintenance, or ideally more checks and maintenance should be carried out.
- (2) Check item in the chart contains check, adjusting, clean, replace and oil.
- (3) Ask a professional repairer to do some items in the chart which can't do by yourself.
- (4) The inlet and outlet valves should be checked after every 1,500km. The valve clearance in cold state is 0.05mm.
- (5) The wear limit of brake shoe's brake pad is 1.5mm, the brake shoes should be replaced as a set.
- (6) Check the swing situation of front and rear wheels often. If wheels swing seriously, find out the reasons and get rid of them.

**NOTE**

**Periodical checks may reveal one or more parts that may need replacement. Whenever replacing parts on your motorcycle, it is recommended that you use genuine Skyteam replacement parts or their equivalent. Whenever you are an expert or do it yourself mechanics, Skyteam recommends that those items on the check chart marked with an asterisk(\*), be performed by your authorized Skyteam dealer or qualified service personnel. You may perform the unmarked items easily by referring to the instructions of this section.**

**LUBRICATION**

The lubrication is very important for ensuring the ability to maneuver all movable parts and prolong the service life of motorcycle. After riding in wet or rainy condition or at throttle fully opened, lubricating all parts of motorcycle is required.

The main points to be lubricated are: Drain chain, brake cable, front brake grip holder, kick starter lever pivot.

**BATTERY AND FUSE**

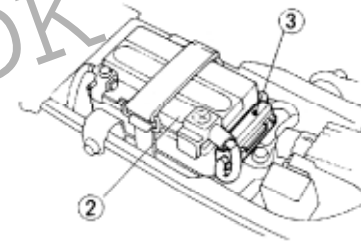
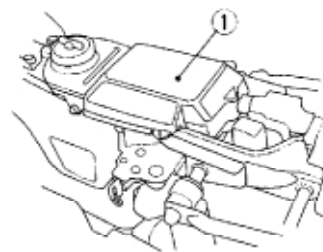

Open the seat cushion and the battery box cover(1), you can see the battery(2) and fuse holder(3). Don't attempt to remove the sealing caps from the cells, it is dangerous and you may damage the battery. Please use a voltage gauge to check the battery charging state(specified voltage is 12.8V).

### CAUTION

**Make sure about poles when connecting electric wires onto the terminal on the battery. Red wires must be connected to positive(+) pole and black wires to negative(-) pole. Incorrect connection can lead to damage to the charging system and the battery.**

The fuse is in the battery box(3), near the battery, the electrical system is protected by a fuse. If there is any electrical system failure while riding, then the fuse must be checked.

### NOTE

**Always be sure to replace the blown fuse with the correct ampere fuse. Never use substitute, for example aluminum foil or wire, to replace a blown fuse. If the spare fuse installed blows in a short period or time it means that you could have a major electrical problem. You should consult your Skyteam dealer immediately.**

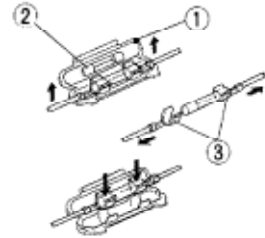

There is spare fuse (2) in the fuse (1), open the fuse holder(3). Replace the blown fuse with a new one and install it into the fuse box.

### AIR CLEANER

If the air cleaner filter assembly has become clogged up with dust, intake resistance will result in the reduction of output power and therefore the increase of fuel consumption. The checks and cleaning to the filter assembly should be conducted with the following procedures for every 3000km.

### NOTE

**If driving under dusty condition, the air cleaner filter assembly must be cleaned or replaced more frequently.**

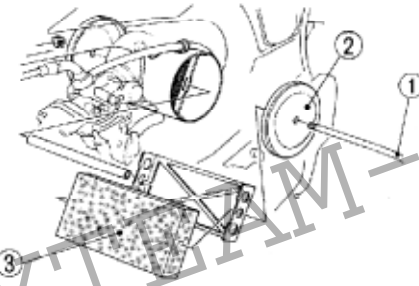

Remove the bolt (1), the air cleaner cover (2) in the figure, take the polyurethane filter assembly (3) out of the air cleaner house.

### CLEANING OF AIR CLEANER FILTER ASSEMBLY

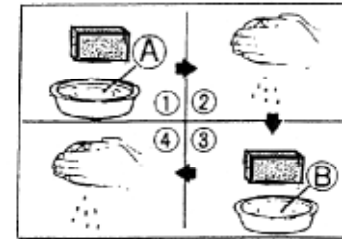

(A)non-flammable cleaning (B)motor oil

Cleaning methods are as follows:

(1)Fill a washing pan of a proper size with non-flammable cleaning solvent, immerse the filter assembly in the solvent and wash it clean.

(2)Squeeze the solvent off the washed filter assembly by pressing it between the palms of both hands. Do not twist and wring it or it will develop fissures.

(3)Immerse the filter assembly in a pool of motor oil and squeeze the oil off it to make it slightly wet with oil.

### NOTE

**Before and during the cleaning operation, carefully examine the element for any tears in the material. A torn element must be replaced with a new one.**

(4)Reinstall the element in the contrary order of removal. Be absolutely sure that the element is securely in position and is sealing properly.

### NOTE

**Never operate the engine without the element in position.**

**Operating the engine without the air cleaner element will increase engine wear. The life of the engine depends largely on this single component.**

### SPARK PLUG

Select the recommended plug: A7TC.



After the first 1000km and afterwards every 3000km riding, remove the carbon deposits from the spark plug with a small metal wire brush or a spark plug cleaner. Readjust the electrode gap of spark plug with a gap thickness gauge to make it between 0.6 to 0.7mm. The spark plug should be replaced after every 6000km riding.

### CAUTION

**The standard spark plug for this motorcycle has been carefully selected to meet the most operation ranges. If the spark plug color differs from a standard one, you should better consult your Skyteam dealer before selecting an alternating plug on a heat range. The selection of an improper spark plug can lead to severe engine damage and driving difficult.**

### CAUTION

**Do not over torque the spark plug otherwise threads of the cylinder head will be damaged. Do not allow contaminants to enter the engine through the spark plug hole when the plug is removed.**

### TRANSMISSION OIL (SHIFTING GEAR OIL)

After a long time driving, the shifting gear oil in the transmission may degrade, which could reduce the lubricating performance of the oil. Therefore, after first 1000km driving and afterwards every 6000km,

change the oil according to the following instructions.

Changing the lubricant oil in the engine should be carried out when the engine is warm.

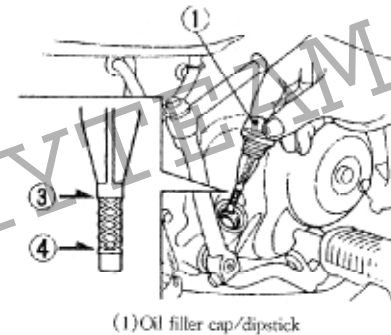

(1) Oil filler cap/dipstick



(2) Drain cock

Remove the engine oil filler cap/dipstick (1) then the drain cock (2) to drain the oil fully. The used oil drainage should be carried out. Then refit the drain cock, pour the new lubricant by the oil filler hole. Check the lubricant level with a dipstick: insert a dipstick into the gear box, the oil level should be between the marks (3) and (4) (Do not screw in the dipstick into the hole).

### CARBURETOR

undisturbed carburetion is the basis of the performance you ought to expect from your engine. The carburetor is factory set for the best carburetion. Do not attempt to alter its setting. There are two adjustments that you should take care are: Adjust engine idle speed and throttle cable play periodically.

## CARBURETOR IDLE SPEED CHECK AND ADJUSTMENT

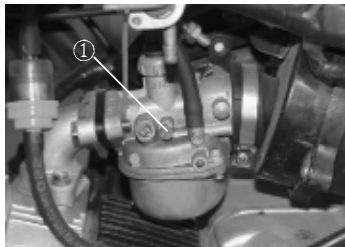

(1) Start up the engine and warm it up.

(2) When the engine is warm, turn the adjusting screw in or out so that the engine may run at its idle speed shown in "SPECIFICATIONS".

### NOTE

The engine idle speed adjustment should be carried out when the engine is in warmed state.

### NOTE

It is suggested that this adjustment be conducted by approved Skyteam dealer.

You can do it yourself with the above procedures if a speedometer is available.

## THROTTLE CABLE ADJUSTMENT

As the figure shown: there is 0.5-1mm slack at the throttle cable. Adjust the throttle cable according to following instruction:

Hold the throttle cable hose to check the slack.

Loosen the lock nut (1) and adjust the cable slack by turning adjuster (2) in or out to obtain the correct slack.

After adjusting the slack, tighten the lock nut(1).

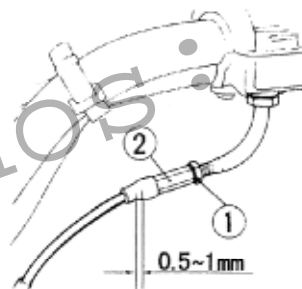

## DRIVE CHAIN

It is suggested that the worn chain replacement be conducted by approved Skyteam dealer.

### WARNING

**In order to assure the maximum safety, the drive chain check and adjustment should be carried out before the riding.**

When performing the periodical check, the following states of drive chain should be checked.

- (1) Loose pins
- (2) Damaged rolls
- (3) Dry and rusty chain links
- (4) Excessive damage
- (5) Twisted and binding links
- (6) Loose drive chain

If the above troubles found, the sprocket is most probably to be damaged. Therefore the following check of the sprocket is necessary:

- (1) Excessively damaged sprocket teeth.
- (2) Broken or damaged sprocket teeth.

(3) Loose lock nuts of the sprocket.

After every 1000km riding, adjust the drive chain tension to ensure the tension distance between 15-25mm. under severe usage, or when the motorcycle is ridden in unusually dusty or muddy areas, more frequent adjustment will be necessary.

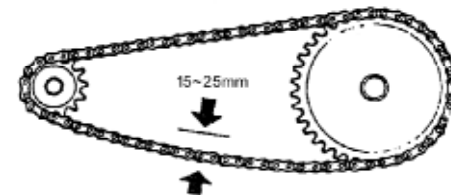

### WARNING

**The adjustment at every 1000km riding is the greatest adjustment interval, in fact before every driving, it is necessary to check the drive chain. Excessive chain slack should cause the chain to come off the sprocket and result an accident or serious engine damage. The transmission chain adjustment should be conducted as per following methods:**

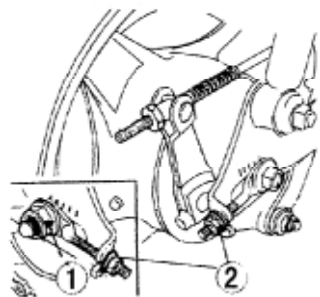

①Cotter pin ②Adjusting nut

- (1)Place the motorcycle on the center stand.
- (2)Screw off the cotter pin (1), then loosen the adjuster nut (2).

#### WARNING

**A burned muffler can scald the person. Even if the engine is shut off, a burned muffler can also scald the person. The drive chain check and adjustment should be carried out after the muffler cooled to avoid the scald.**

(3)Adjust the tension of transmission chain by turning the adjusting nut to the right or the left. At the same time, the alignment of aligning center must also be held. For your convenience of adjustment, reference marks are made on rotating arms and all chain adjusters. They can be aligned with each other and referenced from one end to another Refit the axle nut and new cotter pin and lock the locking nut after adjusting the tension of transmission chain between 15-25mm. Then you can make the final check.

#### NOTE

**Two sprockets should be checked for wear while changing with new sprocket, if necessary, change them with new sprocket.**

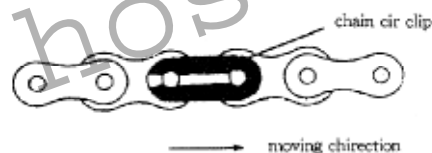

#### CAUTION

**Fit the chain joint clip to the chain with its open end toward the reverse direction of the transmission direction.**

#### DRIVE CHAIN'S CLEANING AND LUBRICATION

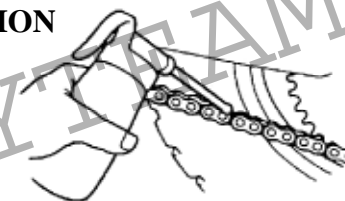

A Dirty drive chain can cause premature wear or damage to the drive chain or sprockets. When the drive chain becomes extremely dirty, it should be removed and cleaned with detergent prior to lubrication, then apply the special sprocket oil or engine oil.

#### BRAKES

This motorcycle has hydraulic disc front brake and rear drum brake. Brakes are items of personal safety and should be properly adjusted. Remember to check periodically the brake system and these checks should be conducted by qualified Skyteam dealer.

#### FRONT BRAKE

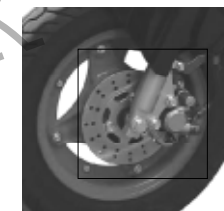

#### BRAKE FLUID

#### WARNING

**Brake fluid may cause irritation. Avoid contact with skin or eyes. In case of contact, flush thoroughly with water and call a doctor if your eyes were exposed**

#### CAUTION

**Do not use the remained brake fluid from a unsealed container, never reuse the brake fluid remained in the last repairing, because the used brake fluid may absorb the water from the air. Use DOT 4 brake fluid from a sealed container. Do not spill out the brake fluid, when the brake fluid is glued to the paint, plastic and rubber material, a chemical reaction shall take place, causing the damage.**

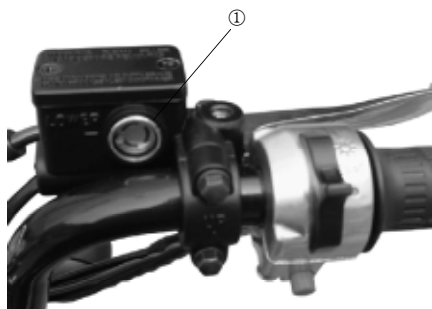

① lower level mark

Check that the fluid level is above the lower level mark ① with the motorcycle in an upright position

Brake fluid must be added to the reservoir whenever the fluid level begins to reach the lower level mark ①. Fill the reservoir up to upper level mark.

#### CAUTION

Check if it is short of brake fluid, check the hose and other components for corrosion or cracks.

### B BRAKE LINING

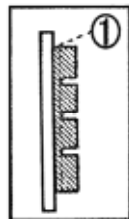
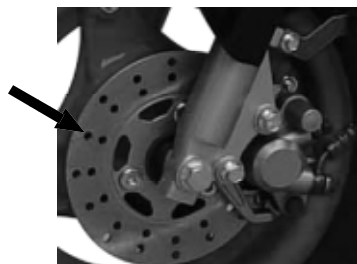

① limit mark

The main points for checking the front brake lining are to see whether the lining wear is out of the range. Replace the brake lining wear is out of the range. Replace the brake lining if the lining wear is beyond the brake wear limit mark.

#### WARNING

If the brake system or brake linings have to be repaired, we suggest that these repair should be performed by your authorized Skyteam dealer. Skyteam dealer knows your motorcycle best and is dedicated to your complete satisfaction.

#### CAUTION

The high pressure brake is used by disc brake system. To ensure the safety, the replacement interval of oil pressure line and brake fluid should not be more than that stipulated in "MAINTENANCE SCHEDULE" of this manual.

Before riding the motorcycle, be sure to check daily the following items:

- (1) Check the front brake system for leakage of brake fluid.
- (2) Check the oil pressure line for leakage of fluid or tears.
- (3) Check the brake lever and brake pedal for free play.
- (4) Check the front brake lining for wear.

#### WARNING

When the new brake lining begins to be used, don't ride your motorcycle immediately after the replacement. Apply the brake, release it, then spin the wheel and check that it rotates freely. Repeat this procedures several times and allow the brake fluid to circulate normally.

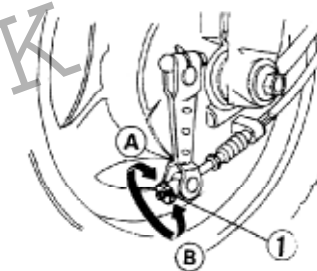

### REAR BRAKE

When adjusting the rear brake, locate the pedal at the most comfort riding position.

When adjusting the travel of brake pedal(1), adjust the free travel to 20-30mm by screwing in or out the rear brake adjusting nut(2).

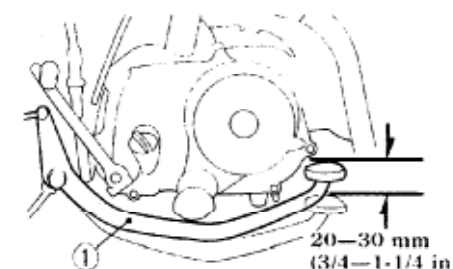

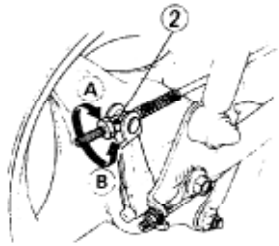

## REAR BRAKE LIGHT SWITCH

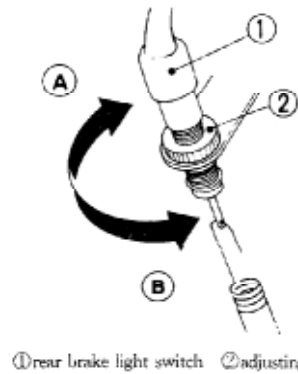

The rear brake light switch (1) is located at the

lower part of right frame. Adjust the brake light switch as the following: turning toward "A" can rise the switch, toward "B" can drop the switch (adjusting nut(2)), thus when the brake pedal is pressed touching the brake, the brake light should be on.

## TIRES

Tire inflation pressure and the general tire condition are extremely important to the proper performance and safety of the vehicle, check your tires frequently for both wear and inflation pressure.

## TIRE PRESSURE

Improper tyre pressure may not only hastens tire wear but also seriously affect the stability of the motorcycle, under inflation may result in the tire slipping, or coming off of the rim causing tire deflation that may result in a loss of vehicle control; over inflated tires make your motorcycle ride more

harshly. Make sure that the tire pressure is in the specified range always. The tire pressure should be adjusted, when the tires are "cold".

Front tire pressure: 250kPa

Rear tire pressure: 250kPa

## TIRE TREAD CONDITION

Operating the motorcycle with excessively worn tires will decrease riding stability and can lead to loss of control. It is recommended that the front and rear tires be replaced when the remaining depth of tire tread becomes 1.6mm or less.

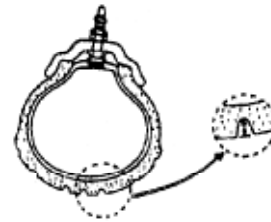

### WARNING

**A standard 3.50-10 4PR tire is used for this motorcycle's front and rear tires. The use of other tires outside standard will cause the unstable riding. Always use the recommended Skyteam genuine tires.**

**Tire inflation pressure and the general type condition are extremely important to the proper performance and safety of the motorcycle. Check your tires frequently for both wear and inflation pressure.**

### CHANGE OF BULB

When replacing a burned bulb, it is required to use the bulb with the same rated power. If you use a bulb beyond the rated power, it may cause the surcharge of electrical system or the bulb damaged. The detail bulb rated power, refer to "electrical system" in "specifications" of this manual.

### TROUBLESHOOTING

If the engine can't be started, please perform the

following checks to find out the reasons.

- (1)Whether there are sufficient fuel in the fuel tank.
- (2)Whether the fuel flows from the fuel cock into the carburetor.
- (3)Cut off the fuel lever from the carburetor, turn the fuel cock to "OFF" position to see whether the fuel flows from the fuel pipe.
- (4)If it is certain that the fuel has flowed into carburetor, the fuel line is normal, then check the ignition system.

### WARNING

**Do not let fuel run off, always keep it in a vessel. Do not splash gasoline on warm engine and air exhausting pipe, keep away from or open flame, never near any fire source or heat source while performing this test.**

- (1)Take off spark plug and connect it again to the entrance spark plug cap.

- (2)Turn ignition switch to ON position, align the spark plug to engine and start the engine. If the ignition system works normally, the blue flare flashed across the spark plug gap; If there is no flare, it needs to repair and contact the Skyteam dealer.

### WARNING

**Don't let the spark plug to be near spark plug opening aperture in cylinder head, because the fuel vapor in the cylinder can ignite causing fire.**

### WARNING

**To reduce an electrical shock possibility, the metallic part of spark plug housing is better in contact with the metallic part of frame no painted. Any person who is cardiac or equipped with cardiac pacemaker should keep away from this test.**

### ENGINE IMPETUS IS NOT GOOD

- (1)Check the fuel supplying system of fuel tank.
- (2)Check the ignition timing of ignition of ignition system.
- (3)Check the engine idle speed.

### NOTE

**Before performing the troubleshooting, it is better to contact with Skyteam dealer. If your motorcycle is still in guarantee period, Skyteam dealer should help you to perform troubleshooting, arbitrary troubleshooting may affect the guarantee contents.**



## SPECIFICATIONS(ST50-6,ST110-6)

### DIMENSION AND DRY MASS

Overall length	1550mm
Overall width	620mm
Overall height	950mm
Wheel base	1075mm
Ground clearance	120mm
Dry mass	76kg
Max. laden weight	100kg

### MAIN PERFORMANCE PARAMETERS

Fuel consumption at economical speed	≤ 1.5L/100km
Rated power	1.6kw(7500r/min) (ST50-6) 4.5kw(7500r/min) (ST110-6)
Max. torque	2.75N.m(4500r/min) (ST50-6) 6.5N.m(4500r/min) (ST110-6)
Idle speed	1350r/min (ST50-6) 1400r/min (ST110-6)

### ENGINE

Model	139FMA-2 (ST50-6) 152FMH (ST110-6)
Type	Single-cylinder, four-stroke, forced air-cooled
Bore x stroke	39mmx41.4mm (ST50-6) 52.4mmx49.5mm (ST110-6)
Piston displacement	49.0cm <sup>3</sup> (ST50-6) 107cm <sup>3</sup> (ST110-6)
Compression ratio	8.8:1 (ST50-6) 9.1:1 (ST110-6)
Starter system	Electric and Kick start
Carburetor	Piston type
Air cleaner	Dry
Lubrication system	Pressure and splash lubrication

### TRANSMISSION

Clutch	Automatic, centrifugal type
Transmission type	4-gear, pedal

### Gear ratio(crankshaft: output shaft)

First gear	13.28:1
Second gear	6.98:1
Third gear	4.83:1
Fourth gear	3.70:1

### CHASSIS

Tire size	Front tire 3.50-10 4PR Rear tire 3.50-10 4PR
Tire pressure	Front tire 250kPa Rear tire 250kPa
Suspension	Spring(front, rear)
Brake	Disc type (front) Drum type (rear)
Steering angle	42° (right and left)
Negative caster	25.5°
Turning dia.	4000mm

### ELECTRICAL

Ignition type	CDI
Generator	Magneto
Battery	12V 4Ah
Spark plug	A7TC
Head light	12V 35W/35W
Turning signal indicator light	12V 10W
Tail/brake light	12V 21W/5W
Instrument indicator light	12V 3W, 12V 1.7W
Horn	12V 1.5A 95dB(A)
Fuse	10A
Fuel tank	2.4L

### CAPACITIES

**All information, illustrations, photographs and specifications contained in this manual are based on the latest product information available at time of publication. Due to improvements or other changes, there may be some discrepancies in this manual. Skyteam reserve the right to make changes at any time without notice.**

hentet hos [www.skyteam.dk](http://www.skyteam.dk)

# ST50-6, ST110-6

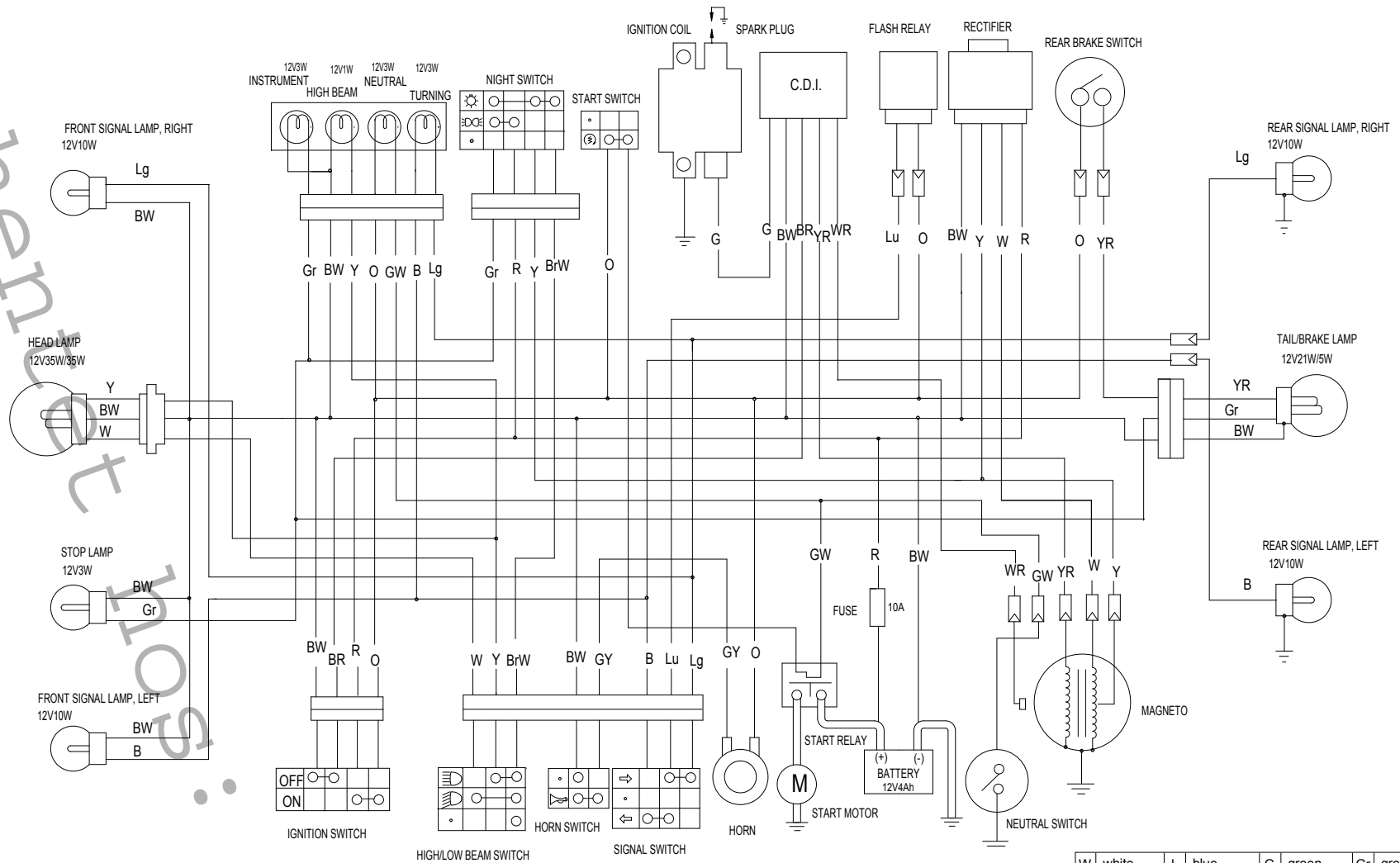

W	white	L	blue	G	green	Gr	grey
R	red	Lg	light green	Br	brown	O	orange
Y	yellow	Lu	light blue	B	black		