



mini maxi

OWNER'S MANUAL

Dear Puch Owner,

This is your riding, maintenance and warranty guide. By following the instructions described in this booklet, we at Puch know you will enjoy many miles of pleasurable Moped Riding.

Should a need ever exist for parts or service, simply contact your Puch dealer. He also has available for your purchase a Service Manual.

Thank you for joining the Puch family, please ride safely and have fun.

INDEX

	see page
Vehicle Identification Numbers	3
Carburetor	5
Choke, Primer	5
Brakes	7
Brake lever Adjustment	8
Engine stop Switch	6
Fuel Valve	5
Gas Tank	4
Gas Oil Mixture	12
Head light	14
Helmet holder	4
Light and horn switch	6
Starter lever, adjustment	11
Steering lock	4
Transmission fluid	13
Tire pressure	11
Riding Instructions	17
General Maintenance and Lubrication	19
Consumer Information	24
Warranty	25

VEHICLE IDENTIFICATION NUMBERS

The vehicle identification number (VIN) is located on the steering head tube.



The frame identification number is stamped into the steering head tube above the vehicle identification number.

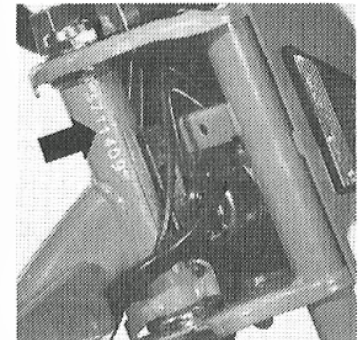

The engine serial number is stamped on top of the right engine case.

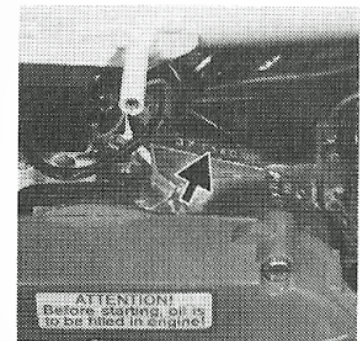

Important: Please check these numbers at the time of sale and compare them with your sales receipt or manufacture statement of origin.

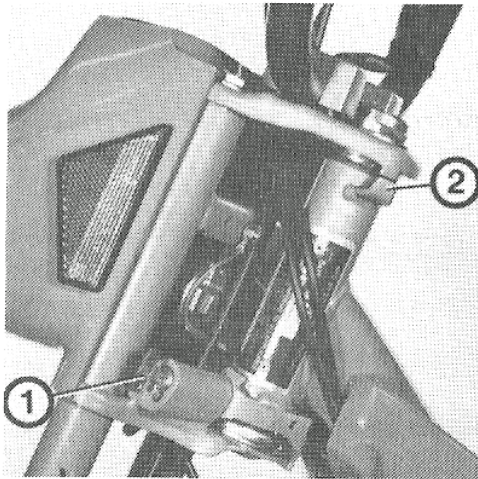

Fig. 1

Steering lock (Fig. 1/1) helmet holder (Fig. 1/2)

To lock: Turn handlebar to the right, insert key and push lock into position by turning the key counter clockwise at the same time. The lock should stay in its position after turning the key clockwise. Pull the key off.

To unlock: Turn lock counter clockwise to free front fork.

Should you decide to lock and secure your helmet with your moped, simply place helmet strap into position (Fig. 1/2) before turning front fork to the right.

Fig. 2

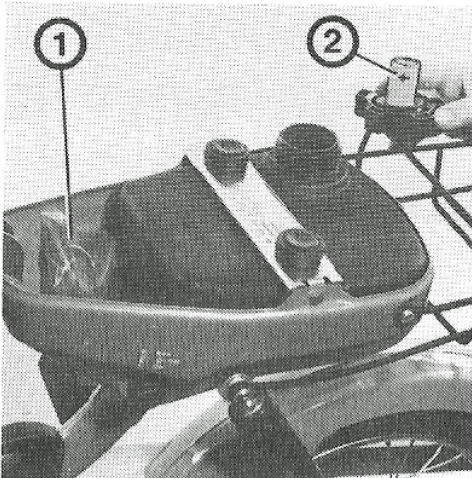

Gas tank (Fig. 2)

The gas tank is located underneath your seat.

To fill gasoline just tilt seat forward to gain access to filler cap (Fig. 2) and storage compartment.

A tool set (Fig. 2/1) and measuring cup (Fig. 2/2) is included.

Fuel Valve (Fig. 3)

The fuel valve is positioned on the l.h. side of your seat bench.

Position 1 = closed

Position 2 = open

Position 3 = reserve

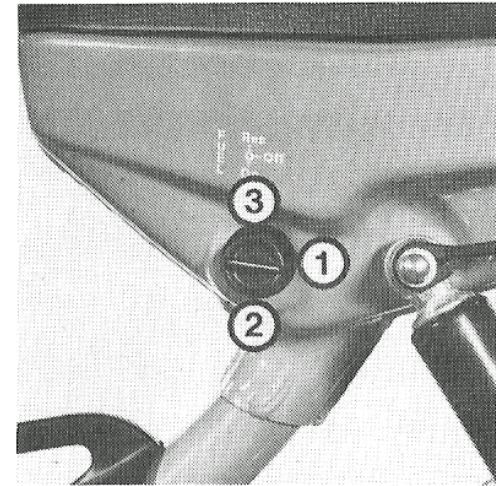

Fig. 3

Fig. 4

Carburetor (Fig. 4)

Choke (Fig. 4/1). Push down to actuate it. The choke will be released automatically (see riding instructions).

Primer (Fig. 4/2). The primer button has to be held down in order to flood the carburetor.

Stop priming as soon as gas drips from carburetor.

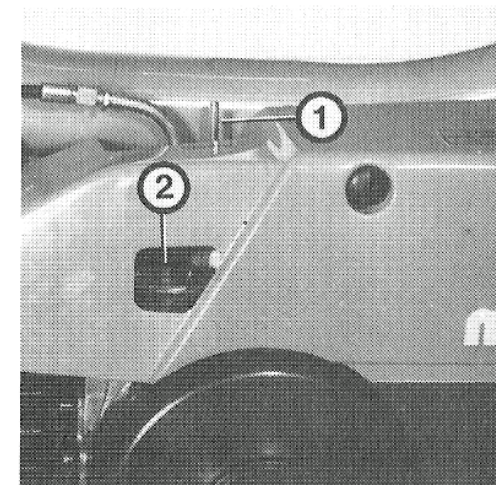

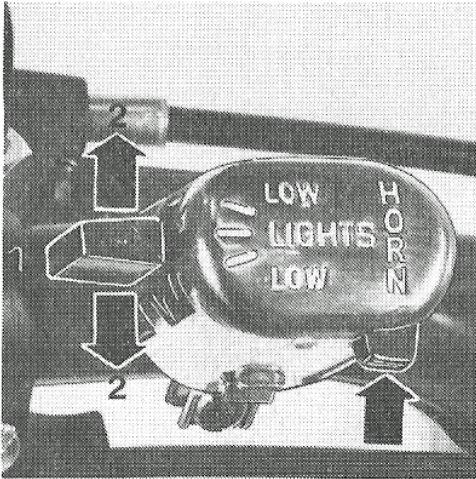

Fig. 5

Light and Horn Switch (Fig. 5)

The light and horn switch is located on the left hand side of the handlebar.

Position 1 = light off

Position 2 = light on

Press button to actuate horn.

Fig. 6

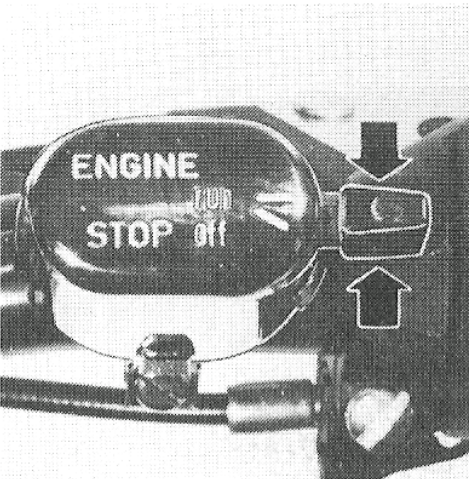

Engine stop switch (Fig. 6)

The engine stop switch is located on the right hand side of the handlebar.

To operate moped, the switch has to be in RUN position.

Switch to OFF in order to turn off the ignition, which stops the engine.

Brakes (Fig. 7)

The brake levers are mounted on both sides of the handlebar.

The left lever (Fig. 7/1) controls the rear wheel brake.

The right lever (Fig. 7/2) controls the front wheel brake.

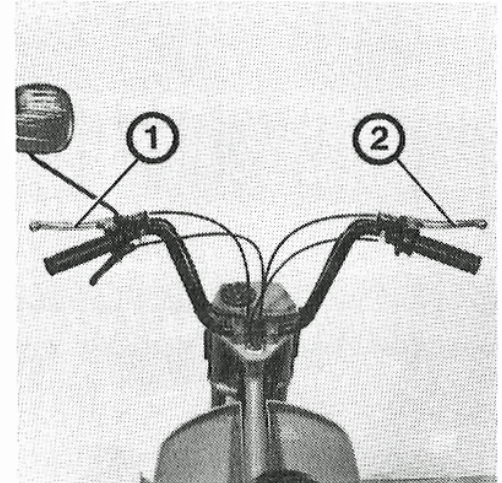

Fig. 7

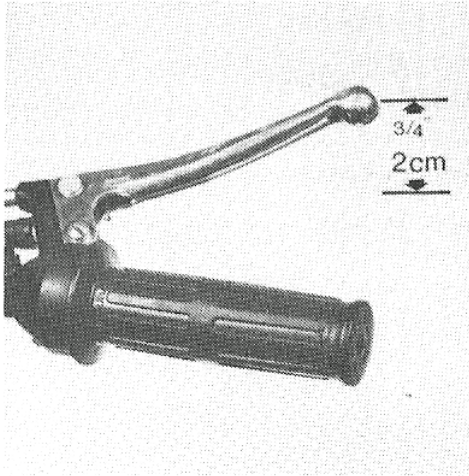

Fig. 8

ADJUSTMENT OF BRAKES

Front Wheel Brake

The brake lever on the handlebar should have a play of app. $\frac{3}{4}$ " as measured at the hand brake lever (Fig. 8). The adjustment is made with the adjustment screw (Fig. 9/1) (loosen conternuts!).

Fig. 9

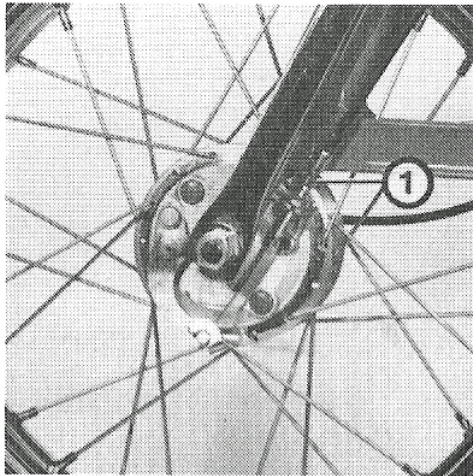

Rear Wheel Brake

The brake lever on the handlebar should have a play of app. $\frac{3}{4}$ " (see Fig. 10). The adjustment is made with the adjustment screw (Fig. 11/1)

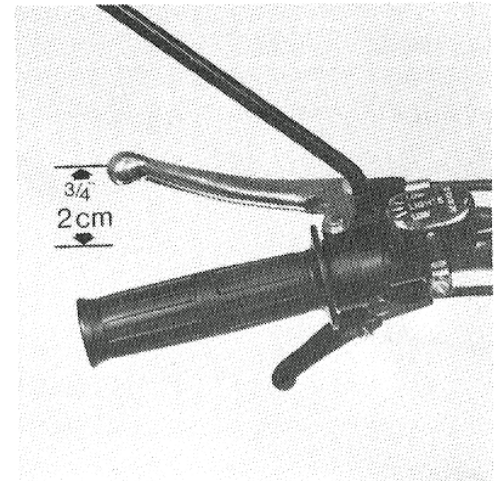
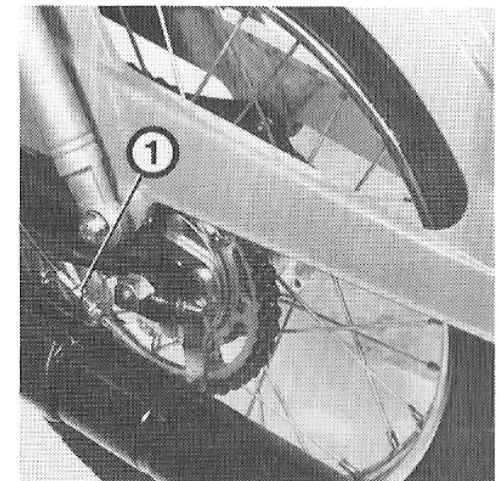

Fig. 10

Fig. 11



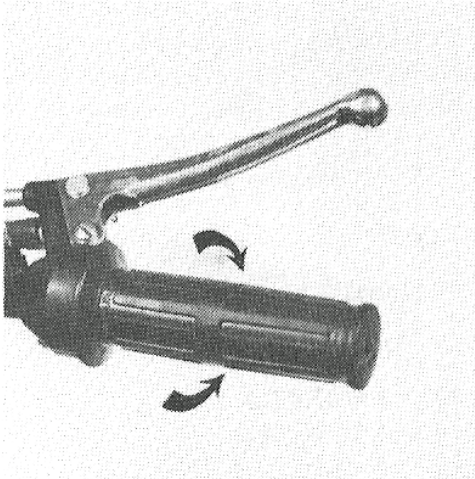

Fig. 12

Throttle twist grip (Fig. 12)

Located on the R.H. side of the handlebar, the twist grip controls the speed of your moped.

To accelerate, twist the grip towards you.

To slow down:

- Release slowly

Fig. 13

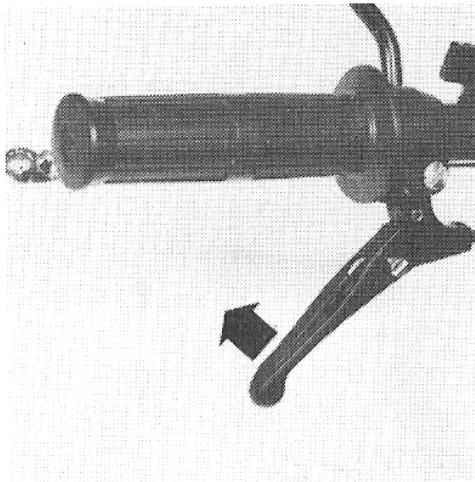

Starter lever (Fig. 13)

The starter lever is mounted on the left hand side of the handlebar and is used only for the purpose of starting the engine.

Press lever hard while pushing the pedal down to start engine.

Release lever after engine is running.

(See also riding instructions)

Warning: Do not press lever while engine is running, since clutch damage can occur.

Adjustment of Starter Clutch Cable

The starter lever should have a play of app. 1/2 inch as measured outside at the lever end. The adjustment is made with the adjustment screw (Fig. 14/1). The rubber cap must be slid back first.

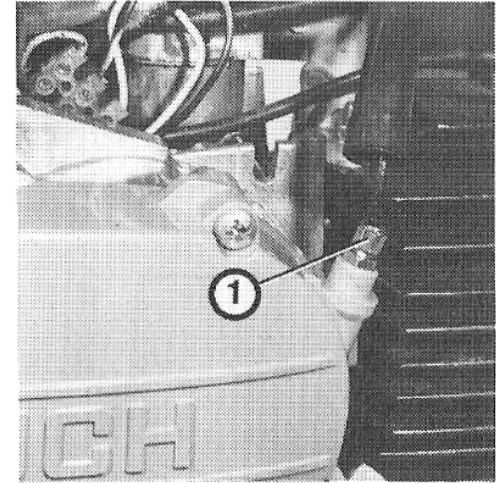

Fig. 14

Tire Pressure

Recommended tire Pressure

Front tire: 32 psi

Rear tire: 32 psi

Caution: Proper tire pressure is important, since under inflated tires can cause hazardous riding situations and are subject to excessive wear.



Fig. 15

Fig. 16



Gasoline/Oil Mixture

Filling up with two stroke mixture

All MAXI engines must be run with a gas/oil mixture (regular gas). The recommended mixing ratio is 50:1 when using special Maxi Mix two stroke moped oil.

NOTE: DO NOT USE UNLEADED GASOLINE

PUCH MAXI MIX

50 : 1 OIL MIXING TABLE

To 5 gallons gasoline add 12 fl. oz. (379 cc) oil

To 1 gallon gasoline add 2.4 fl. oz. (76 cc) oil

To 1 quart gasoline add. 6 fl. oz. (19 cc) oil

Use measuring cup for proper amounts of oil.

Ask your PUCH dealer for maxi mix oil.

NOTE: When using other brands of 2 stroke oil, do not exceed the 50:1 mixing ratio.

WARNING

NEVER REFUEL WITH THE ENGINE RUNNING!

DO NOT SMOKE OR ALLOW OPEN FLAMES OR SPARKS IN THE AREA WHERE YOUR MOPED IS REFUELED AND/OR WHERE GASOLINE IS STORED! CHECK WITH LOCAL AUTHORITIES ABOUT THE STORAGE OF GASOLINE.

Transmission Fluid

The oil level screw (Fig. 17/1) serves also as the filler plug and is located on the clutch cover.

The drain plug (Fig. 17/2) is located on the lower engine case.

To fill oil: The moped must be in a level position when oil is filled (off kick-stand).

Use automatic transmission fluid type „F,, only.

The quantity of oil is 6¾ fl. oz. (200 cc) or fill until oil levels off at the bottom of the thread of filler plug.

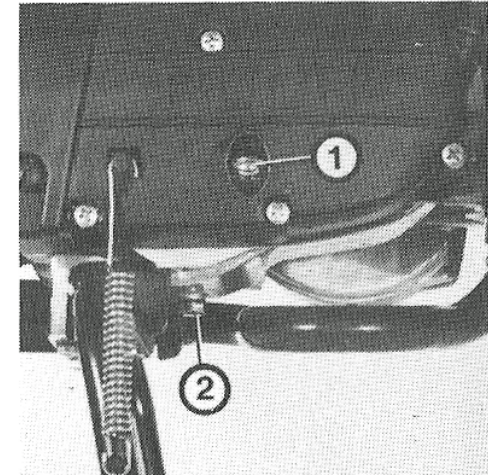

Fig. 17

Exchanging the Headlight Bulb

Loosen screw (Fig. 19/1).

Push headlight covering to the top and then pull it to the front. Twist bulb socket (Fig. 20) in the direction of the arrow. Exchange bulb. When remounting the covering, make sure that the pinion of the covering (Fig. 20/1) engages in the bore provided at the lower fork bridge.

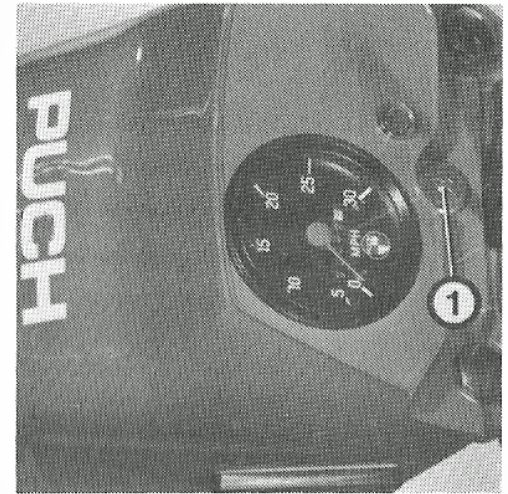
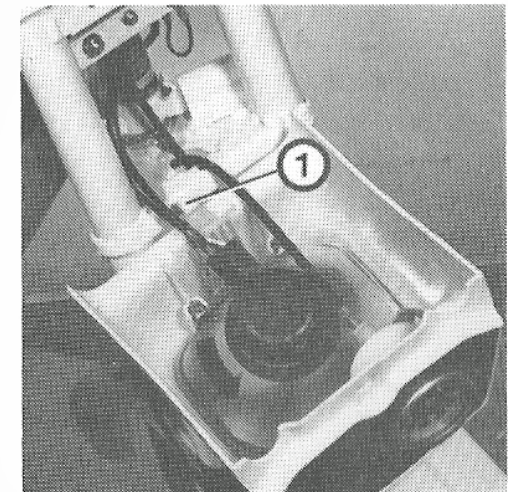

Fig. 19

Fig. 20



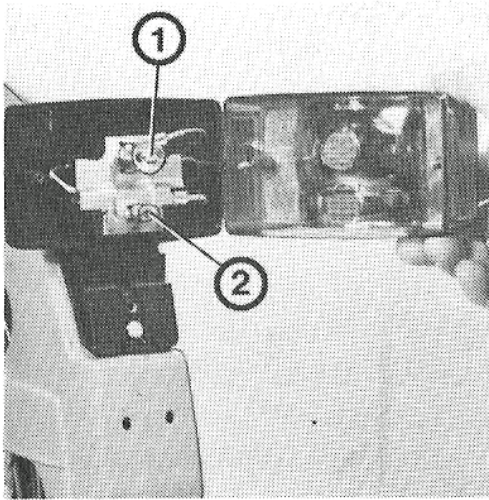

Fig. 21

Exchanging the Tail and Stop Bulb

Loosen the taillight screw and remove lens. Exchange the bulb.

- 1 Stoplight
- 2 Taillight

WARNING: Due to strict lighting regulations use only original replacement bulbs.

RIDING INSTRUCTIONS

Starting the Moped

1. Prop the moped on its stand.
2. Unlock fork.
3. Turn fuel valve to the ON position.
4. Be sure that the engine stop is in the RUN position.
5. If engine is cold, depress the choke and depress the primer button on the carburetor until fuel drips from carburetor.
6. Keep both hands on the handlebar with the weight of the moped centered on the front wheel. Apply the front brake and fully depress the starting lever located on the left side of the handlebar. Position the pedal approx. parallel to the chain guard.
While holding the starter lever, push the pedal to start engine.

CAUTION: After completing step 5 and 6 do not open the throttle control, as this will deactivate the choke. After the engine has started and warmed up, open throttle gently to the full position briefly. This will disengage choke. Avoid racing engine.

7. Alternate starting method:
The moped may also be started by pedalling as a bicycle. When momentum has been gained, pull the start lever and gently open the throttle. Release the start lever after the engine starts.

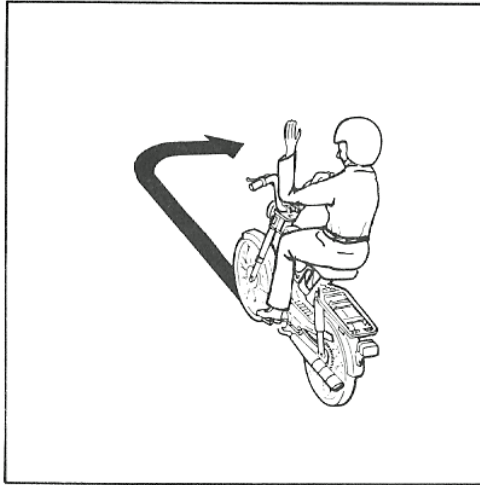
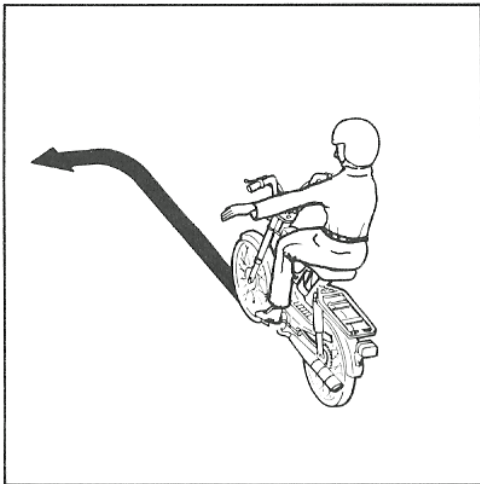

Fig. 22

Fig. 23



RIDING

1. It is suggested to wear bright clothing, utilize eye protection, and proper shoes or boots when riding your moped.
2. Wearing a helmet is recommended even though optional in many states. See your local PUCH DEALER or check with local law enforcement agencies for state law requirements.
3. Be sure to switch on headlight at low visibility and/or where required by law.
4. The moped is designed to carry ONE person. Do not carry a passenger or very heavy cargo. Approved PUCH saddle bags and baskets are available through your dealer.
5. Obey all traffic regulations. Use hand signals when turning or changing lanes. Please respect property of others and ride carefully. Keep your feet on the pedals at all times. Keep the pedals level, especially on turns.
6. After reaching maximum speed, reduce the throttle opening to 3/4. While a reduction in speed will hardly be noticeable, fuel consumption however will be considerably reduced.
7. Closed throttle will slow down moped when riding downhill.
8. To ensure engine lubrication on long downhill rides, open throttle occasionally.

General Maintenance

Should you feel able to perform small maintenance work on your moped, make sure that all nuts and bolts are tight and all other components are in good working condition.

A service manual is available through your PUCH dealer.

Any maintenance or service work requiring special tools and mechanical skills should be performed by your local PUCH dealer.

NOTE: The use of non PUCH authorized spare parts can cause malfunction and hazardous riding situations for you.

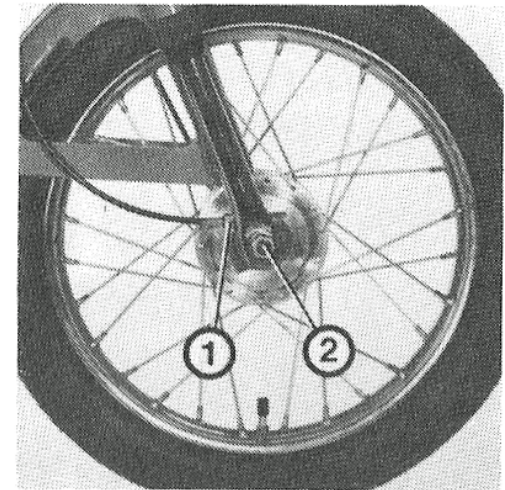
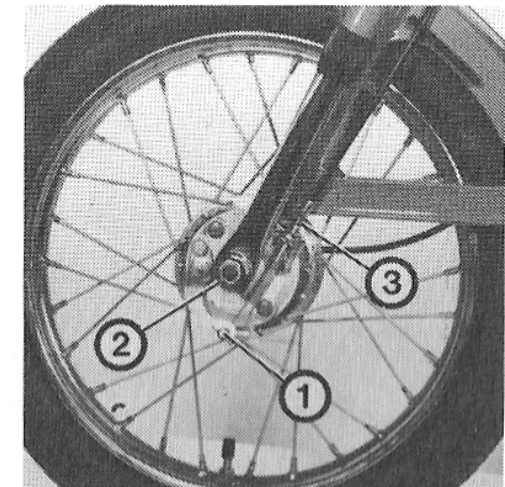

Fig. 24

Fig. 25



Removal of front wheel

Unscrew speedometer cable (Fig. 24/1). Remove brake cable assembly (Fig. 25/1), if necessary, loosen setscrew (Fig. 25/3). Loosen axle nuts (Figs. 24/2 and 25/2). Remove wheel.

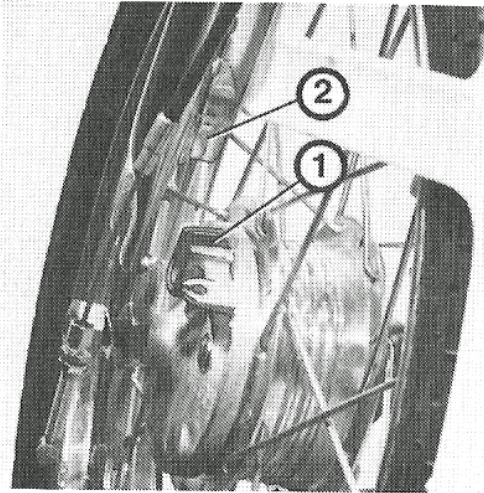

Fig. 26

NOTE: When reinstalling the wheel, make sure that the brake anchor plate (Fig. 26/1) engages into the pinion of the front fork (Fig. 26/2).

WARNING: Make sure both axle nuts (Fig. 24/2 and 25/2) are tightened.

Removal of rear wheel

Remove brake cable assembly, if necessary, loosen setscrew (Fig. 27/4). Loosen chain tensioning screws (Fig. 27/1 and Fig. 28/1). Loosen both axle nuts (Fig. 27/2 and 28/2). Detach chain tensioner from grooves. Push wheel forward. Remove chain (Fig. 27/3) from drive sprocket. Pull off the rear wheel with vehicle tilted to the left.

When remounting the wheel, check chain tension and tighten axle nuts.

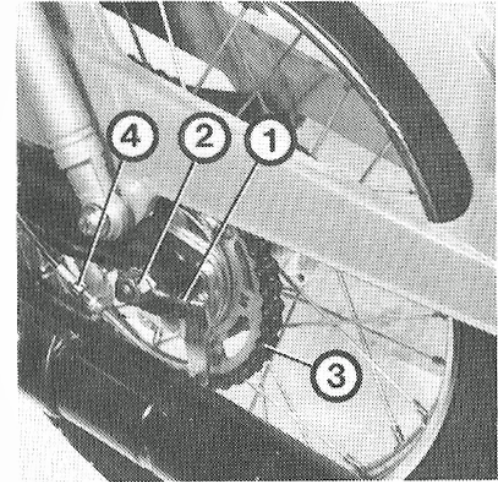
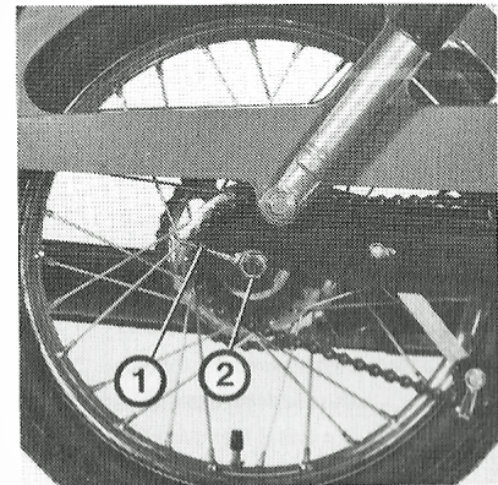

Fig. 27

Fig. 28



Retightening the Bolts and Nuts

Check bolts and nuts for tightness. Pay particular attention to engine mounting bolts, front and rear axles and spring strut fastening screws.

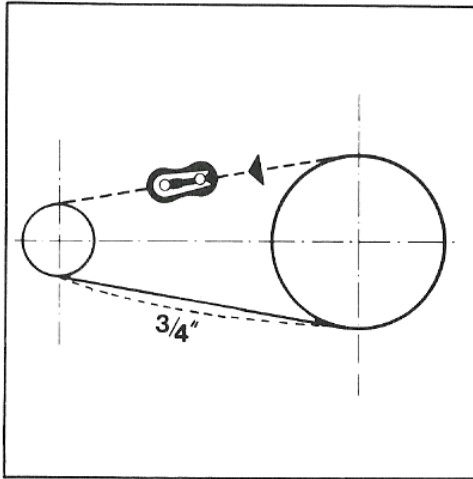

Fig. 29

Chains

Engine drive-and pedal chain should be kept clean. Every few hundred miles wipe chains thoroughly clean with a cloth. Lubricate with chain lubricant or SAE 90 oil.

Always keep chains properly tensioned. The proper slack of the drive chain should be $\frac{3}{4}$ ".

To adjust chains, loosen the axle nuts and tighten or loosen the adjuster nuts. Once chains are properly adjusted, tighten the axle nuts. Make sure that wheel is properly aligned.

When reinstalling the chain also pay attention as to the correct position of the chain lock (closed part in riding direction) and to proper chain tension.

If pedal chain tensioner catches or travels roughly as pedals are operated, realign tensioner so chain travels smoothly.

SUGGESTED MAINTENANCE AND LUBRICATION CHART

A regular maintenance and lubrication schedule will help to ensure a long, useful life for your moped. Please refer to the mileage and lubrication chart for detailed information.

NOTE: Above milage schedule applies to moped used on dry paved surface. If used in wet, muddy or sandy area, maintenance intervals should be more frequent.
Always check controls and lights before using your moped.

Frequency

		First 300 miles	Every miles					OPERATIONS TO PERFORM
		300	600	900	1800	3600	7200	
RECOMMENDED SERVICE	•		•	•	•	•	•	Tire wear and condition
	•							Throttle cable adjustment
	•		•	•	•	•	•	Check tire pressure
	•			•	•	•	•	Check transmission ATF level
	•			•	•	•	•	Clean and lubricate chain
	•				•	•	•	Clean air filter
	•					•	•	Change transmission ATF
	•			•	•	•	•	Check spark plug
	•				•	•	•	Decarbonize engine
	•				•	•	•	Clean exhaust baffle
	•					•	•	Retighten screws and nuts
	•					•	•	Clean fuel valve and lines
	•					•	•	Clean carburetor
	•					•	•	Idle speed adjustment
	•					•	•	Check ignition timing
•				•	•	•	Adjust starter cable	
•				•	•	•	Check brake cables/linings	
•					•	•	Check/lubricate hub bearings	
•					•	•	Steering bearing adjust/lubrication	
•				•	•	•	Lubricate control cables	
•				•	•	•	Adjust chain tension	

CONSUMER INFORMATION

CONSUMER INFORMATION

Stopping Distance

Vehicle minimum stopping Distance on dry ground

This figure indicates braking performance that can be met or exceeded by the vehicles to which it applies, without locking the wheels, under maximum condition of loading. The information presented represents results obtainable by skilled drivers under normal road and vehicle conditions, and the information may not be correct under other conditions.

Description of vehicles to which this table applies: MINI-MAXI

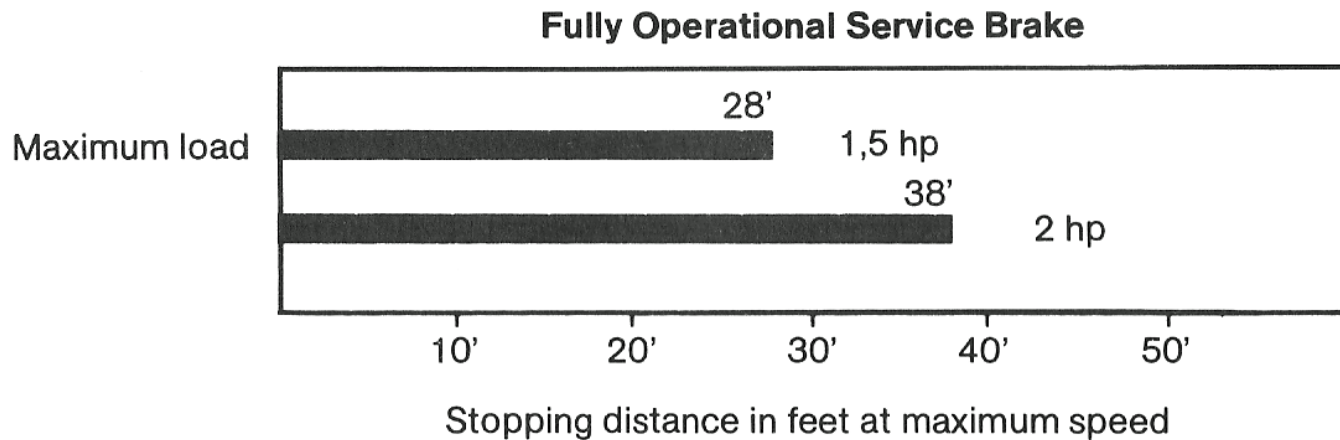



Technical Data

mini maxi

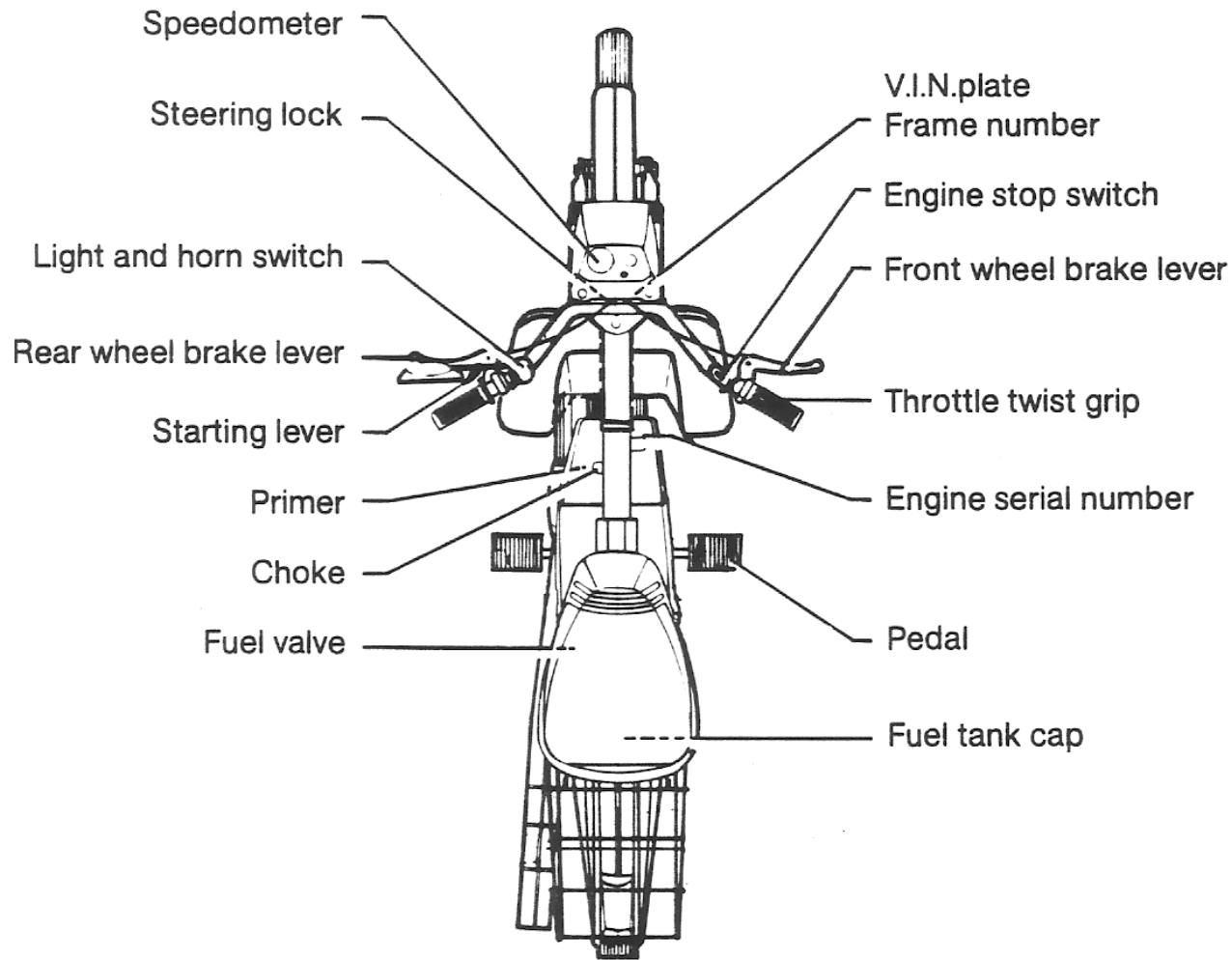

WIRING DIAGRAM

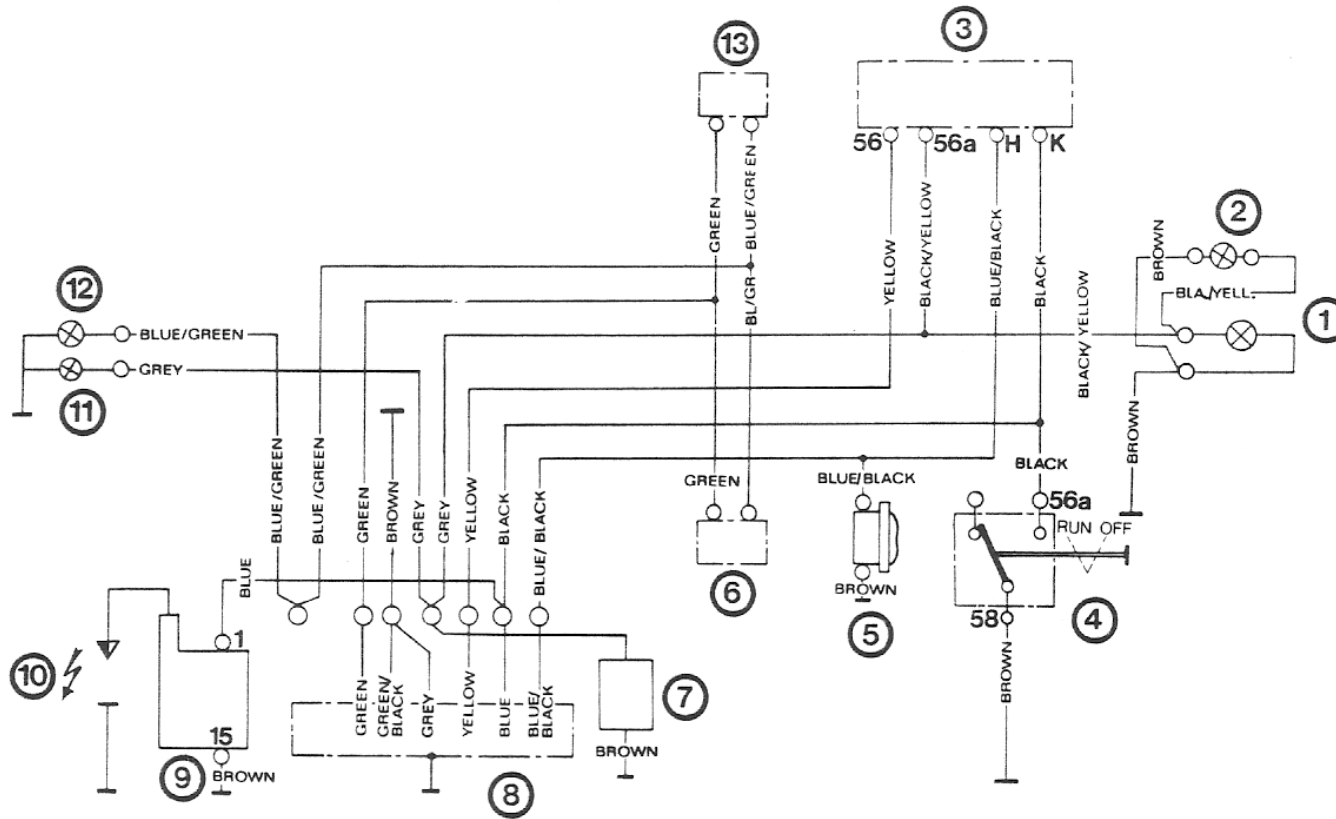

- | | | |
|-------------------------|---------------------------|----------------------|
| 1 Headlamp | 6 Stop light switch | 10 Spark plug |
| 2 Speedometer bulb | 7 Regulator | 11 Tail light bulb |
| 3 Light and horn switch | 8 Fly wheel magneto BOSCH | 12 Stop light bulb |
| 4 Engine stop switch | 9 Ignition coil | 13 Stop light switch |
| 5 Buzzer | | |

ENGINE

Maximum output	1.5 hp at 5000 r.p.m
Compression ratio	8.5:1
Maximum output	2.0 hp at 5500 r.p.m
Compression ratio	8.5:1
Bore	1.496 in (38 mm)
Stroke	1.693 in (43 mm)
Displacement	2.97 cu. in (48.8 cc)
Cooling	air cooled
Lubrication	gas/oil mixture
Carburetor	1.5 hp BING 1/12
Main jet	52
Needle jet	2.12 A
Needle position	1st notch from top
Carburetor	2.0 hp BING 1/12
Main jet	54
Needle jet	2.12 A
Needle position	1st notch from top
Ignition	magneto ignition
Breaker point gap	.014-.018 in (0.35-0.45 mm)
Ignition timing	.032-.047 in (0.8-1.2 mm) BTDC = 14-17.5°
Spark plug	1.5 hp BOSCH W8C
Spark plug	2.0 hp BOSCH W7C
Spark gap	.016-.020 in (0.4-0.5 mm)
Dynamo	flywheel magneto BOSCH 6V 26-5/10W

POWER TRANSMISSION

Gearbox	single speed automatic
Clutch	centrifugal clutch running in ATF
Primary transmission	helical gears
Secondary transmission	chain 1/2 "x 3/16"
Pedalling chain	chain 1/2 "x 1/8"

GEAR RATIOS

Engine gear	1.5 hp 96:19; i = 5.052
Gear-rear wheel	39:14; i = 2.785
Pedalling transmission	28:23; i = 1.217
Engine gear	2.0 hp 96:19; i = 5.052
Gear-rear wheel	39:15; i = 2.6
Pedalling transmission	28:23; i = 1.217

CHASSIS

Frame	tubular frame
Front wheel suspension	telescopic fork; 1.96 in (50 mm) spring travel
Rear wheel suspension	shock absorbers; 1.77 in (45 mm) spring travel
Brakes	internal expanding shoe brakes
Dia. of brake drum	3.15 in (80 mm)
Width of brake lining	0.7 in (18 mm)
Tire size front and rear	2.50-14"
Tire pressure front/rear	32 psi/32 psi (2.25 bar/2.25 bar)
Fuel tank	.93 US gal. (3.5 litres)

WEIGHTS AND DIMENSIONS

Wheelbase	43.3 in. (1100 mm)
Overall length	63.8 in. (1620 mm)
Overall width	28.4 in. (720 mm)
Overall height	39.8 in. (1010 mm)
Ground clearance	5.1 in. (130 mm)
Curb weight	105.8 lb (48 kg)

ELECTRICAL EQUIPMENT

Headlamp bulb	6V, 15W
Rearlamp/Stoplamp bulb	6V, 4W/6V, 10W
Warning device	buzzer

PERFORMANCE AND CONSUMPTION

Top speed	1.5 hp 25 mph (40 km/h) 2.0 hp 30 mph (48 km/h)
Hill climbing ability	11-14%
Standard fuel consumption (DIN 70030)	1.5 hp 148 m/US gal (1.78 l/100 km) 2.0 hp 144 m/US gal (1.98 l/100 km)

Test commences on a flat track in top gear at 3/4 top speed. The track length of 6.2 m (10 km) is used either way and may have very short upward and downward gradients of a maximum of 1.5%. The vehicle must be adjusted to specification and tires must have correct pressure. The rider must not weight more than 143.32 lbs (65 kg). The measured consumption is increased by 10% to take into account unfavourable conditions. Production may differ up to 5% from this value.

CAPACITY AND QUALITY OF LUBRICANTS

ENGINE	Mixture of regular grade gasoline with special two stroke oil (MAXI MIX) 50:1. Do not use unleaded gasoline.
GEARBOX	6¾ oz. (200 cc) Automatic Transmission Fluid " TYPE F"
GREASE NIPPLES, CABLES	Summer and winter grease. For lubrication of the grease nipples also SAE 90 can be used. For lubrication of the cables also SAE 30 can be used.
WHEEL BEARING	Summer and winter Lithium base grease.
CHAIN	Summer and winter SAE 90.

ASSEMBLY INSTRUCTIONS - PUCH MINI MAXI

1. Remove the Moped from its container.
2. Set the Moped on its kick stand.
3. Remove accessory box from container.
4. Begin assembly by removing protective packing.
5. Install front fender and secure with the four (4) screws provided (screws are located in the fork sliding tubes).
6. Install front wheel and torque axle nuts to 35-50 Nm (25-36 ft/lbs).
Note: Both axle nuts and washers are located on one (1) side of the axle. Install front wheel with brake reacting slot on left hand side (operator's view).
Assure that brake stop on fork leg and brake backing plate interlock. Connect speedo cable and check for speedo operation.
7. Position the handlebar on the fork bridge, making sure electrical wiring is not crossed. Attach with the four (4) allen head bolts provided. Before torquing bolts, align the handlebar so that it is running parallel with the front fork. Torque bolts to 15-16 Nm (10-12 ft/lbs).
8. Place throttle twist grip into shackle and mount to handle bar.
9. Mount both electrical switches and secure wiring with the tie-wraps to the handle bar.
Caution: secure electrical wiring only, not brake cables.
10. Install front brake cable and adjust brake.
11. Install pedals. Note: Pedals are marked "L" - left hand side, and "R" - right hand side.
12. Install rear view mirror and adjust as required.

13. Installation of leg shield:
- a) locate the four sleeves (1) into the mounting holes of the leg shield, see arrow.
 - b) place lower clamp (2) over frame tubing and position sleeve (3) in clamp.
 - c) position leg shield (4) over lower clamp (2) and install clamp stud (5).
 - d) install both upper mounting bolt (6).
Tighten all nuts.

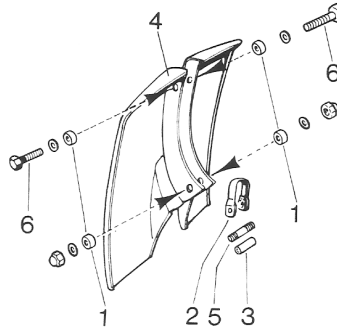

14. Fill transmission with automatic transmission fluid (TYPE - F only) refer to owners manual.
15. Fill gas tank with gas oil mixture, refer to owners manual.
16. Tighten all nuts and bolts
17. Short test drive and clean machine.
18. Please, carefully instruct customer how to safely operate the moped.