

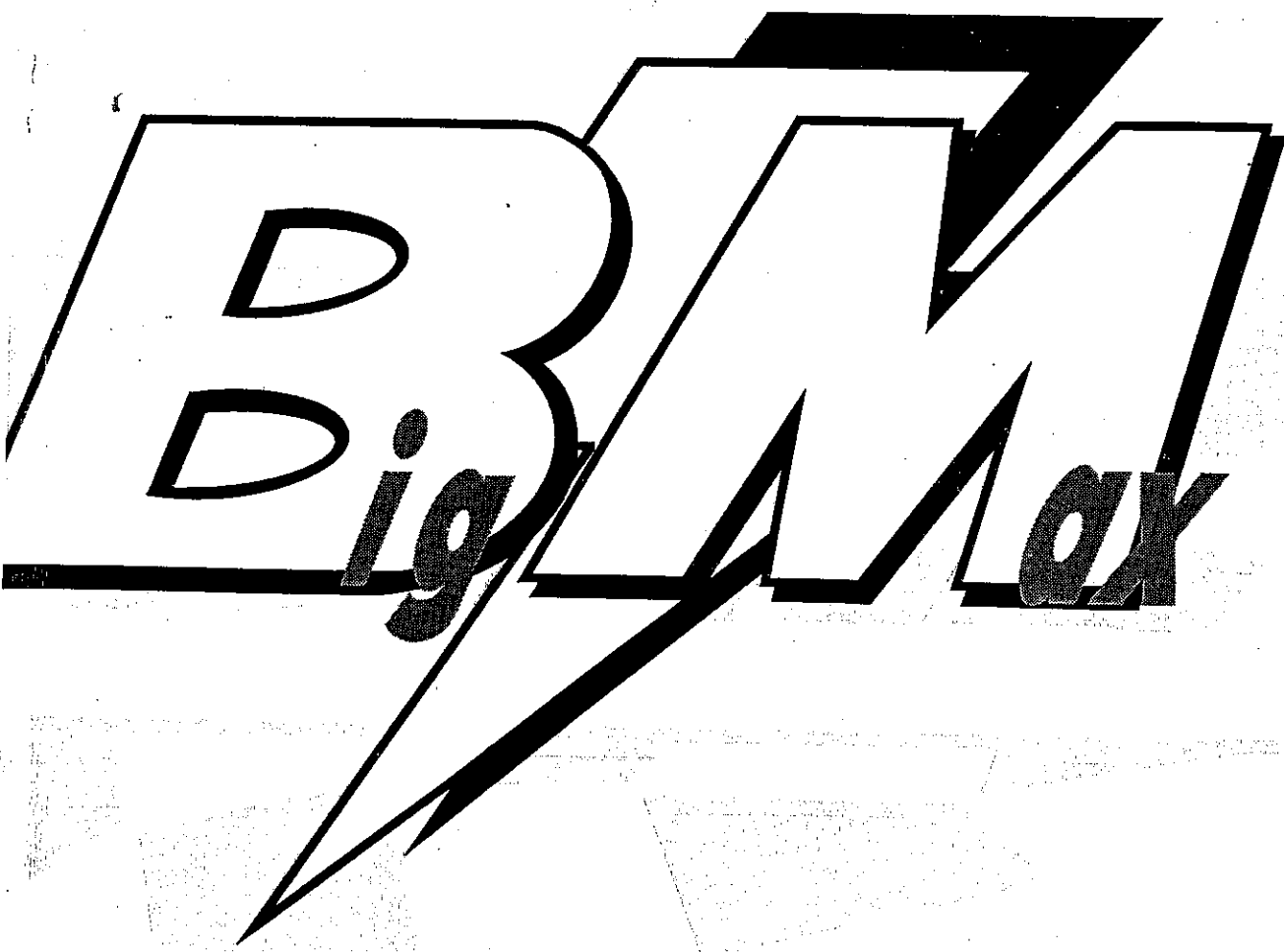

**PS - 50 D**

**SERVICES MANUAL**



**PGO SCOOTERS**

## PREFACE

This manual offers all service specialist with the technological procedures of maintenance , repairing for BIG-MAX Detailedly show those whom may concern how to maintain,repair, change parts,troubleshoot and reassemble,etc.

At any important section we illustrate by assembly, explosion diagrams and photographs,if necessary please check the diagrams already shown.

Though we have tried our best ,please kindly instruct us any faults in this manual.

TAIWAN P.G.O. CO.,LTD.

# CONTENTS:

Page

一、 The specification of BIG-MAX.....	4
二、 Service information.....	5
(1) The notice for operation.....	6
(2) Torque value.....	7
(3) Lubrication instruction.....	9
(4) Wiring diagram.....	12
(5) Troubleshooting.....	15
三、 Checking and Adjustment.....	23
(1) Dated checking table.....	24
(2) Battery.....	28
(3) Cleaning air cleaner.....	29
(4) Final reduction mechanism oil.....	29
(5) Spark plug.....	30
(6) Compression pressure measurement.....	31
(7) Ignition timing.....	31
(8) Throttle cables adjustment.....	32
(9) Idle adjustment.....	33
(10) Frt brake adjustment.....	34
(11) Rear brake adjustment.....	35
(12) Wheel.....	36
四、 Dismantling, maintaining, repairing and assembling operation....	37
(1) Lubrication system.....	38
(2) Plastic parts of chassis.....	43
(3) Engine dismantling.....	49
(4) Drive pulley, starter, clutch, driven pulley.....	54
(5) Cylinder head, cylinder, piston.....	64
(6) AC alternator flywheel magneto.....	75
(7) Final transmission mechanism.....	79
(8) Crankcase, crankshaft.....	84
(9) Carburetor.....	93
(10) Steering column, front wheel, frt brake comp., front fork.....	100
(11) Rear wheel, rear brake, rear damper.....	110

	Page
(12) Fuel tank, oil tank.....	115
五、Electric equipment.....	122
(1) Troubleshooting.....	123
(2) Battery.....	124
(3) Recharge system.....	125
(4) Ignition system.....	128
(5) Starting system.....	129

## — 、 Specification:

Name:BIG-MAX	ignition:CDI	Front wheel pressure:
Model:	start:kickstarter or	1.3 kg/cm <sup>2</sup>
Size:	electric start.	Rear wheel pressure:
overall length:1710mm	Lubrication:separated	1.5 kg/cm <sup>2</sup>
overall width : 670mm	Lubrication type	
overall height:1110mm	Chassis:steel pipe	
overall base :1195mm	Front absorber:expanding	
Weight:	& contracting	
net weight:84kg	Rear absorber:unit swing	
front :33kg	Drive train:	
rear :51kg	Primary reduction:	
total :84kg	CVT	
carrying capacity:	Sceondary reduction:	
2 passengers and 110	52/13 × 44/13=13.538	
kg	Clutch type:centrifugal	
total weight :194kg	type	
front :61 kg	Selector:infinite va-	
rear :133kg	riable speed(CVT)	
total :194kg	Wheel dimension & layres:	
Performance:	rear:130/90-10	
consumption :45km/L	front:120/90-10	
gradient ability :19°	Front brake:hand brake	
Engine:	disk by oil pressure	
model : P1	type	
fuel :unlead	Rear brake:hand brake	
cooling:forced cool	lining expanding by	
by fan	mechanism type	
Cylinder:	Speedometer:80 km/hr	
bore:40mm	Head lamp :12V 18W/18W	
stroke:39.2mm	License plate lamp:	
number:1	12V-15W	
arrangement:horizo-	Brake lamp:12V-10W	
ntal	Turn lamp :12V-10W	
displacement:49cc	Horn:12V DC	
compression ratio:	Silencer:diffusible	
6.8:1	absorption closed type	
	Muffler location and	
	direction:	
	Chassis lower right s-	
	ide f engine backward	

## 二、Service information:

	Page
(1) The notice for operation.....	6
(2) Locking torque value.....	7
a. For engine	
b. For chassis	
c. Others	
(3) Lubrication instruction.....	9
a. For engine	
b. For chassis	
(4) wiring diagram.....	12
(5) Troubleshooting.....	15
a. Hard starting or no starting	
b. Bad pick up	
c. Running not smoothly(slow speed)	
d. Running not smoothly(high speed)	
e. Clutch, drive, driven pulley	
f. Handlebar steering when running	
g. Front and rear damper not even	
h. Bad braking	
i. Oil gauge	
j. Fuel gauge	
k. Starting motor	

## (1) The operation notice :

1. Always replace gasket , oring , cotter , pins and circlip whenever reassembled.
2. Tighten fastener, beginning on center or larger dia bolts to specs, where sequence is not specified in an x patter.
3. Use PGO. or PGO. recommeded parts.
4. After dismantling please wash all parts necessary for checking and grease all contact surface when reassembling.
5. Use grease recommended by P.G.O.
6. When removing battery, please disconnect the negative pole(-) first when assembling please connect positive pole(+) first.
7. Before installing a new fuse, confirm the specification is correct or not.
8. After reassembling, please confirm that all connecting point, locking parts, circuits, polar characteristics are good, before selling out.

## (2) Torque value:

### 1. Engine

No	locking location	Thred dia(mm)	Locking torque kgf-m	Remarks	
1	cylinder head	6	1.0-1.2	When the engine is cold	
2	flywheel plate	10	3.2-4.0		
3	rear brake lever	6	1.0-1.2		
4	driving pulley	10	3.2-4.0		
5	clutch outer	10	3.5-4.0		
6	right crankcase	6	1.0-1.2		
7	drive gear box cover	6	1.0-1.2		
8	left crankcase	6	1.0-1.2		
9	draining bolt	8	1.8		When the engine is cold
10	inlet pipe	6	1.0-1.2		
11	flywheel magneto	6	1.0-1.2		
12	cooling fan	6	1.0-1.2		
13	muffler nut on cylinder head	6	1.0-1.2		When the engine is cold
14	starting motor	6	1.0-1.4	When the engine is cold	
15	brocket between eng. and rubber pad of central stand	6	1.0-1.2		
16	spark plug	14	2.5-3.0		
17	fan cover	6	1.0-1.2		
18	fixed plate, drive clutch	6	1.0-1.4		
19	nut of rear wheel axle	14	8.0-10.0	U TYPE NUT	
20	kick starter	6	1.0-1.2		

### 2. Chassis

1	steering stem nut	10mm	3.0-4.0	lock nut
2	front axle nut	12mm	5.0-6.0	(U type nut)
3	fixed nut fasten eng. and chassis	12mm	5.0-6.0	(U type nut)
4	rear shock absorber (upper)	10mm	3.0-4.0	
	rear shock absorber (lower)	8mm	2.0-3.0	
5	lock nut fasten frt. brake disk and frt. wheel rim	8mm	2.0-3.0	lock nut
6	lock bolt between frt. brake pump and frt. absorber	8mm	2.0-3.0	lock bolt



3. Other parts please refer the following table:  
Standard torque values:

No	Item	Torque kgf-m
1	5mm bolt and nut	0.45-0.6
2	6mm bolt and nut	0.8 -1.2
3	8mm bolt and nut	1.8 -2.5
4	10mm bolt and nut	3.0 -4.0
5	12mm bolt and nut	5.0 -6.0
6	5mm screw	0.35-0.5
7	6mm screw	0.7 -1.1
8	6mm flange bolt and screw	1.0 -1.4
9	8mm flange bolt and screw	2.0 -3.0
10	10mm flange bolt and screw	3.0 -4.0

### (3) Lubrication instruction:

#### A. Engine

No	Lubrication parts	Oil type	Remarks
1	crankcase inner rotating, sliding part.	premium 2 cycle	auto-separated lubrication
2	cylinder inner rotating, sliding parts.	motorcycle oil or SAE#30	
3	drive gear box	SAE#90	110cc
4	gasket of starter shaft	clean grease	
5	start idle gear sliding parts	clean grease	

B.Chassis parts

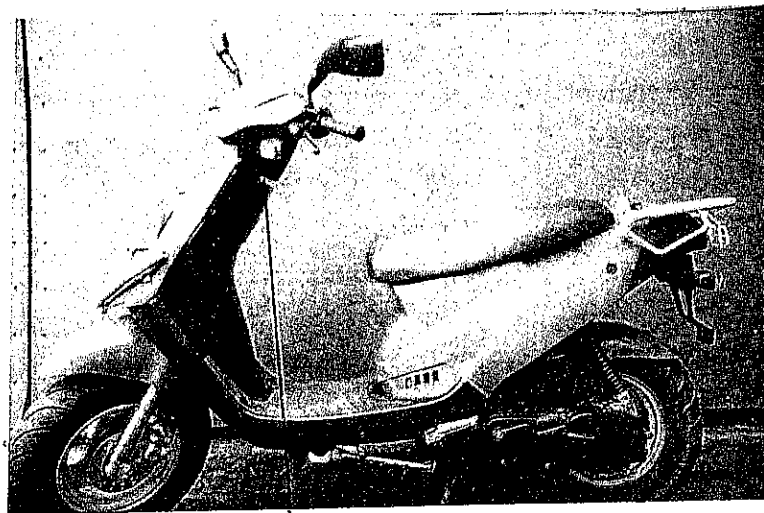

steering column steel  
ball-clean grease

FRT. brake comp-brake oil

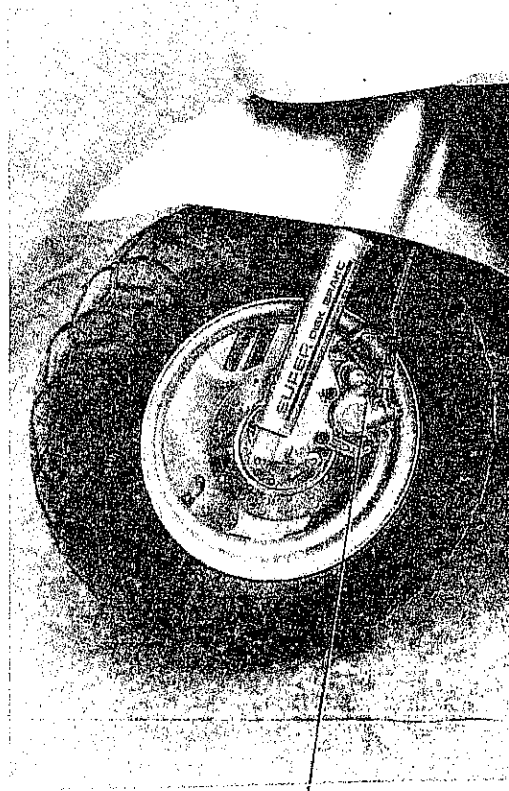
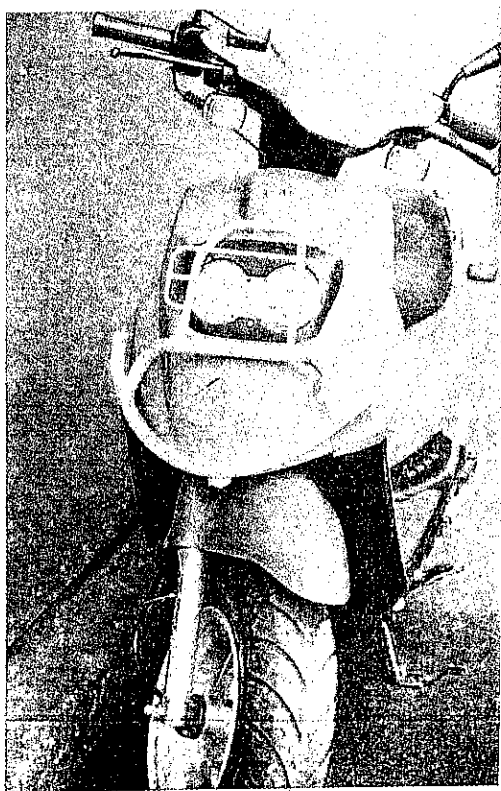

brake cam pin-clean grease

Wheel bearing part

Final drive mechanism-oil

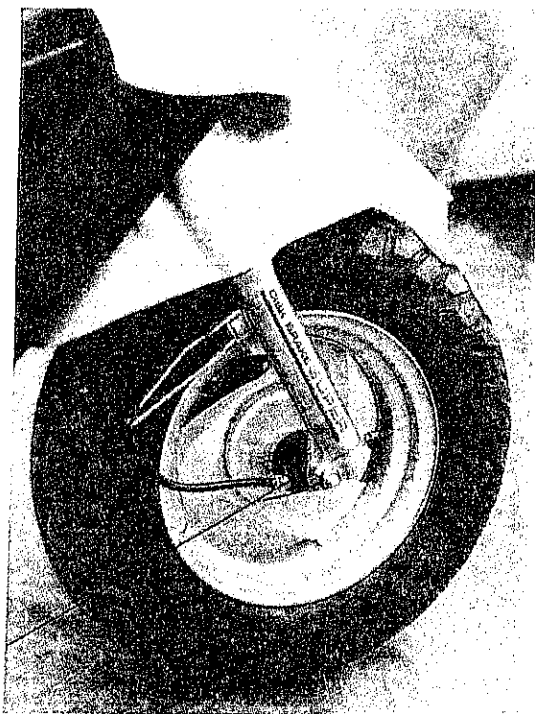
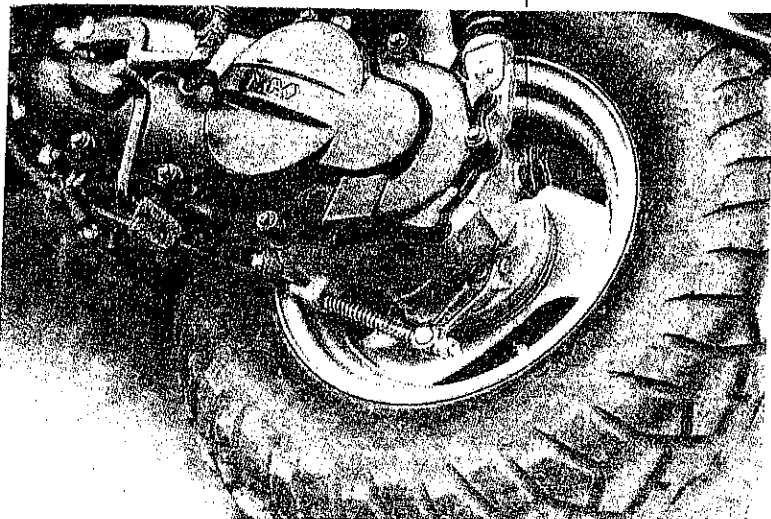

speedometer gear - clean grease

Frt. wheel bearing - clean grease



2 Front chassis cable assembling diagram

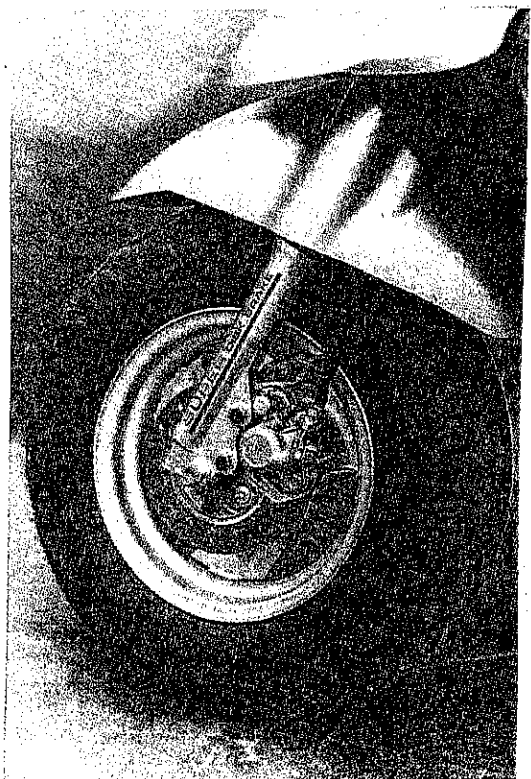
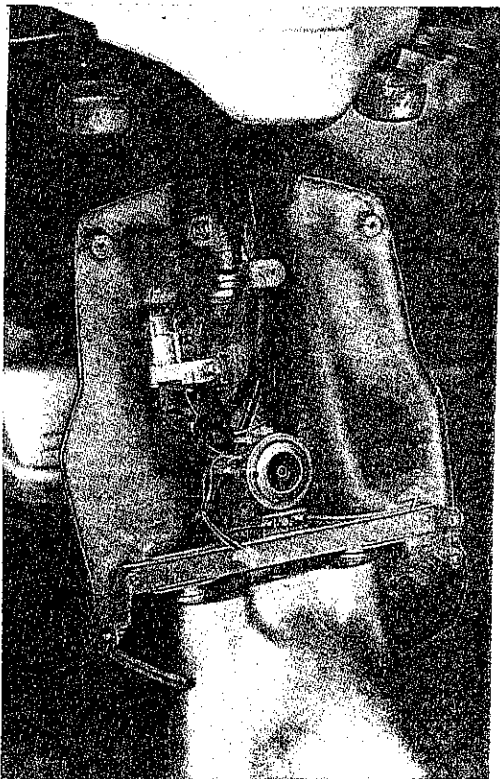
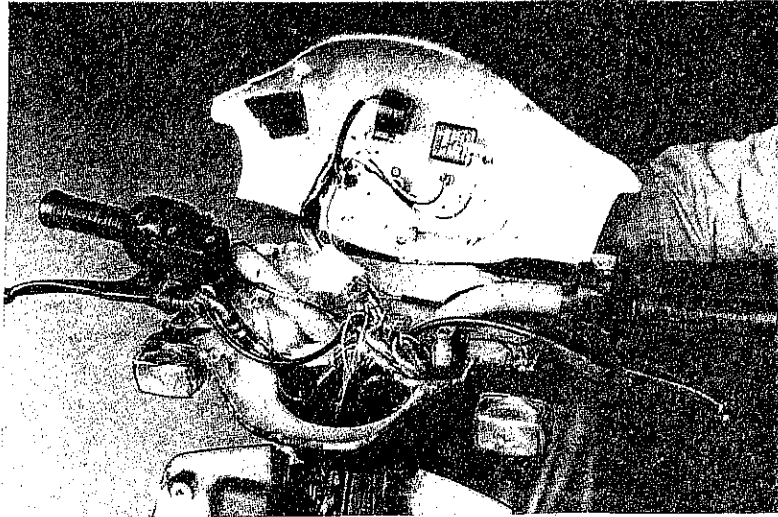

3 Rear chassis cable assembling diagram

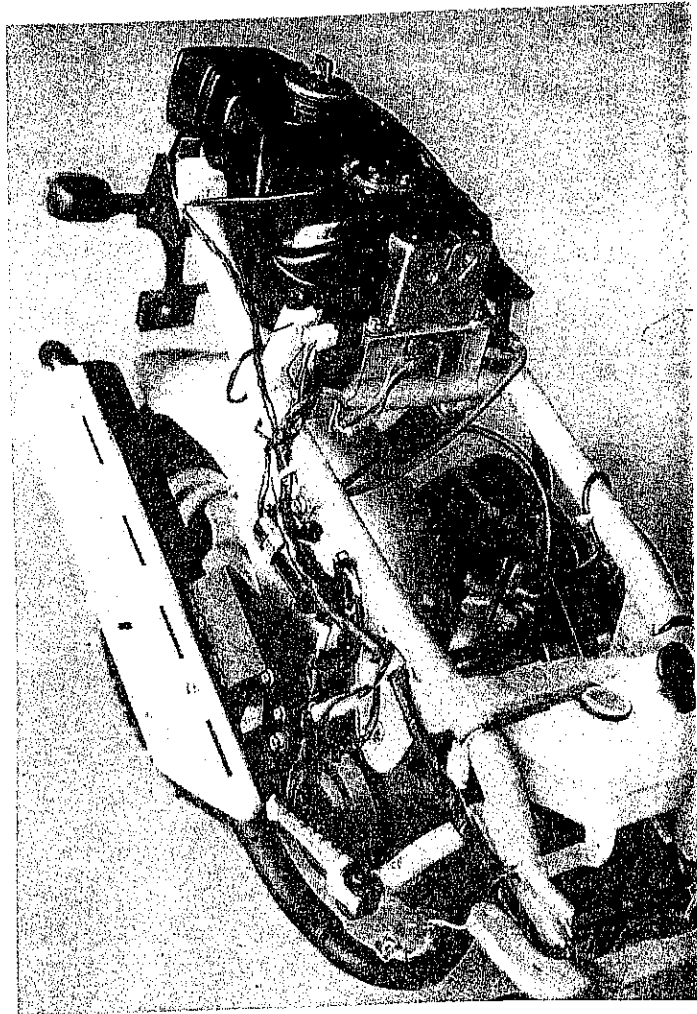

# (5) Trouble shooting:

1. Hard starting or can't start:

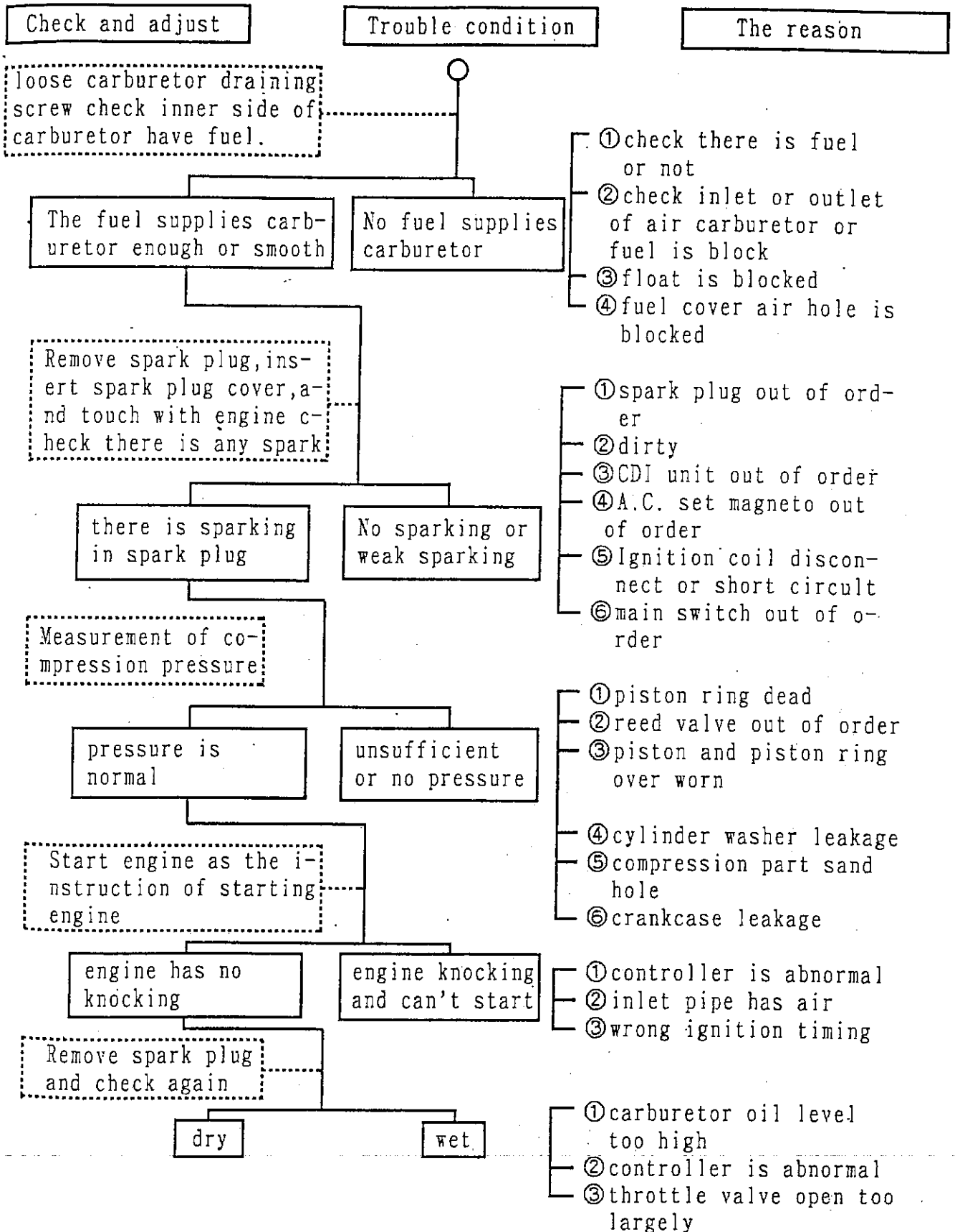



## 2. Weak acceleration; deficient horsepower

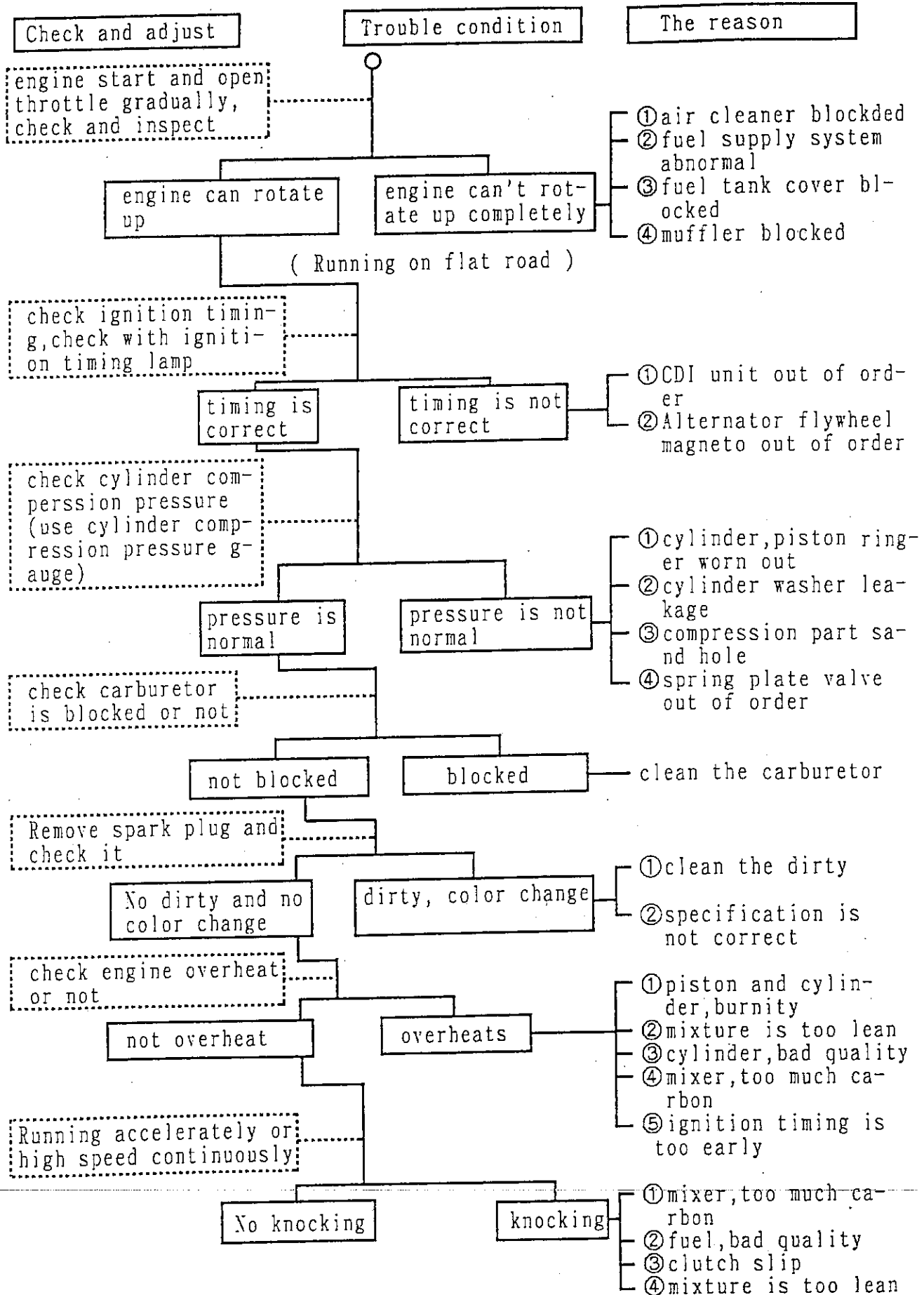

### 3. Engine running unsmoothly (low speed and idling)

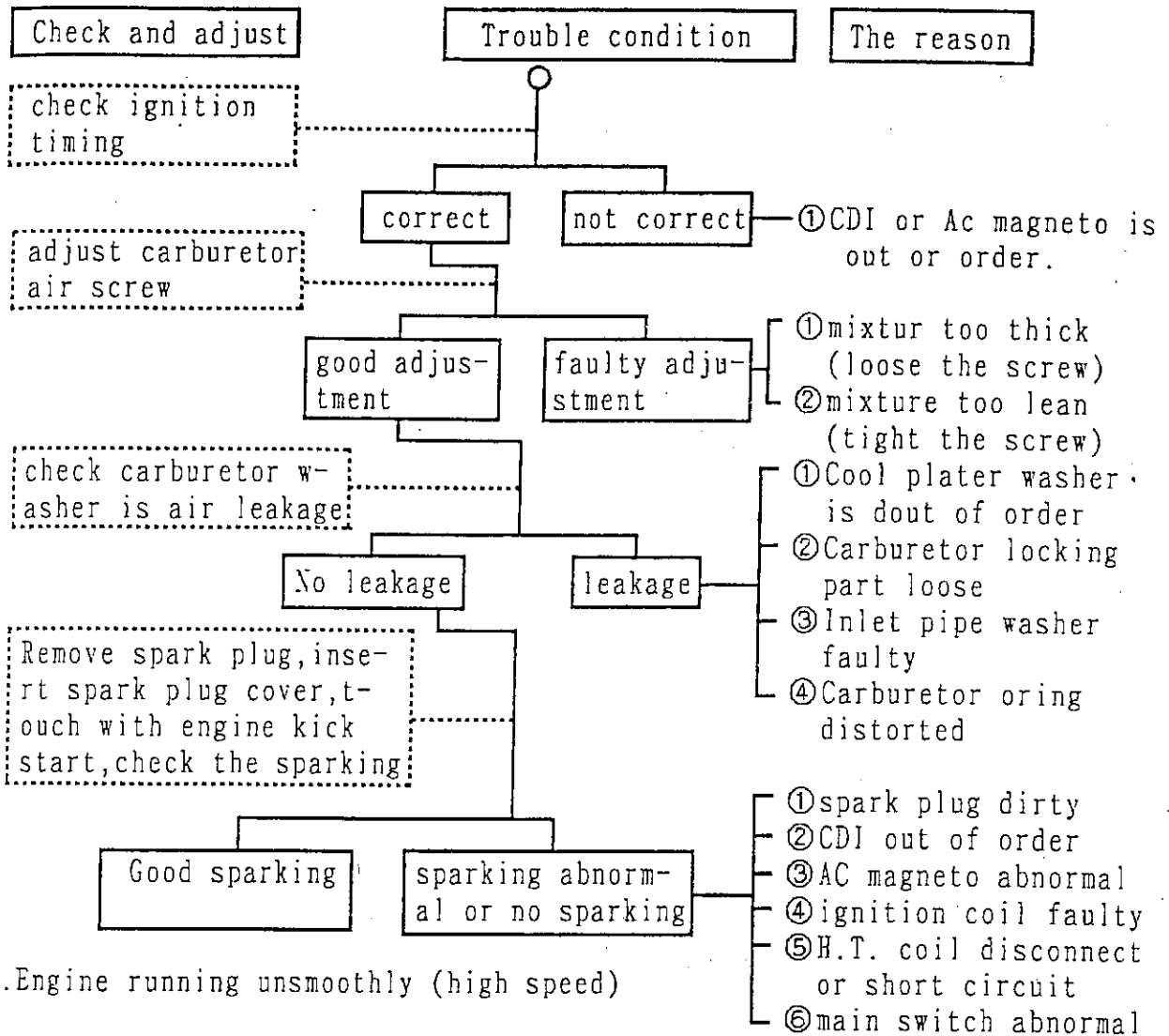

### 4. Engine running unsmoothly (high speed)

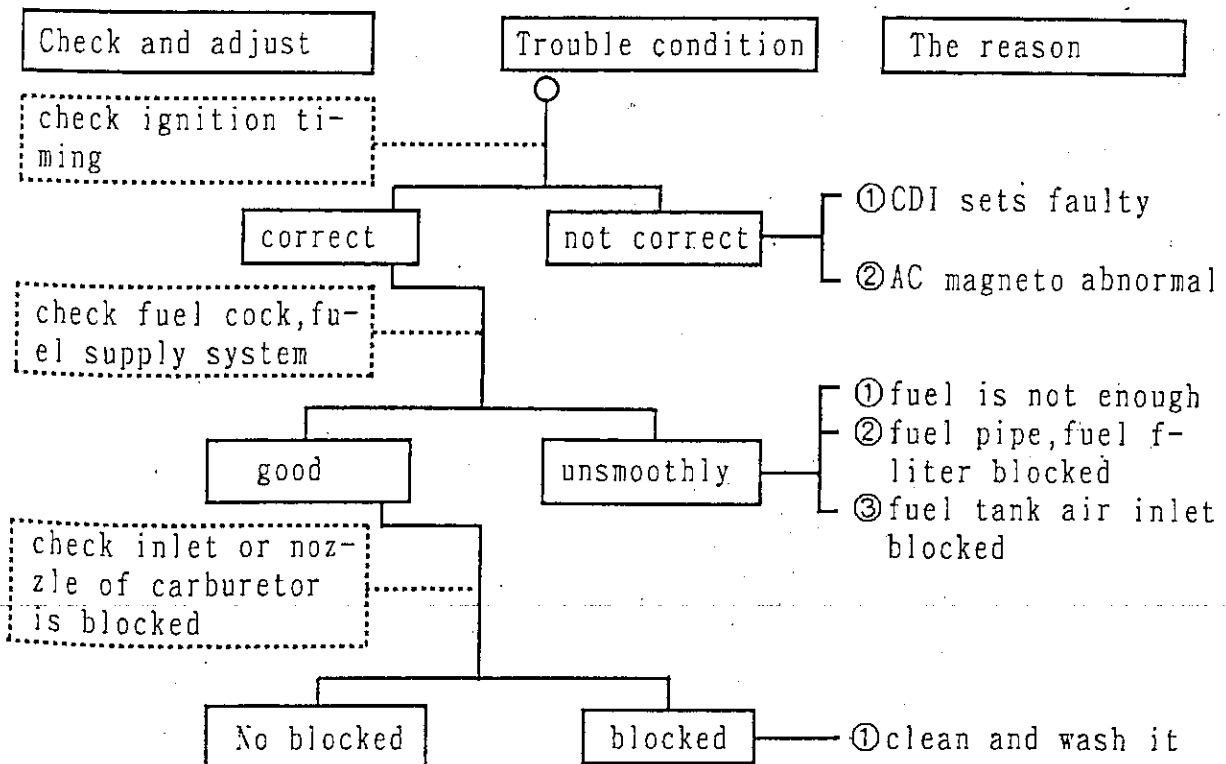

5. clutch, deive, driven pulley

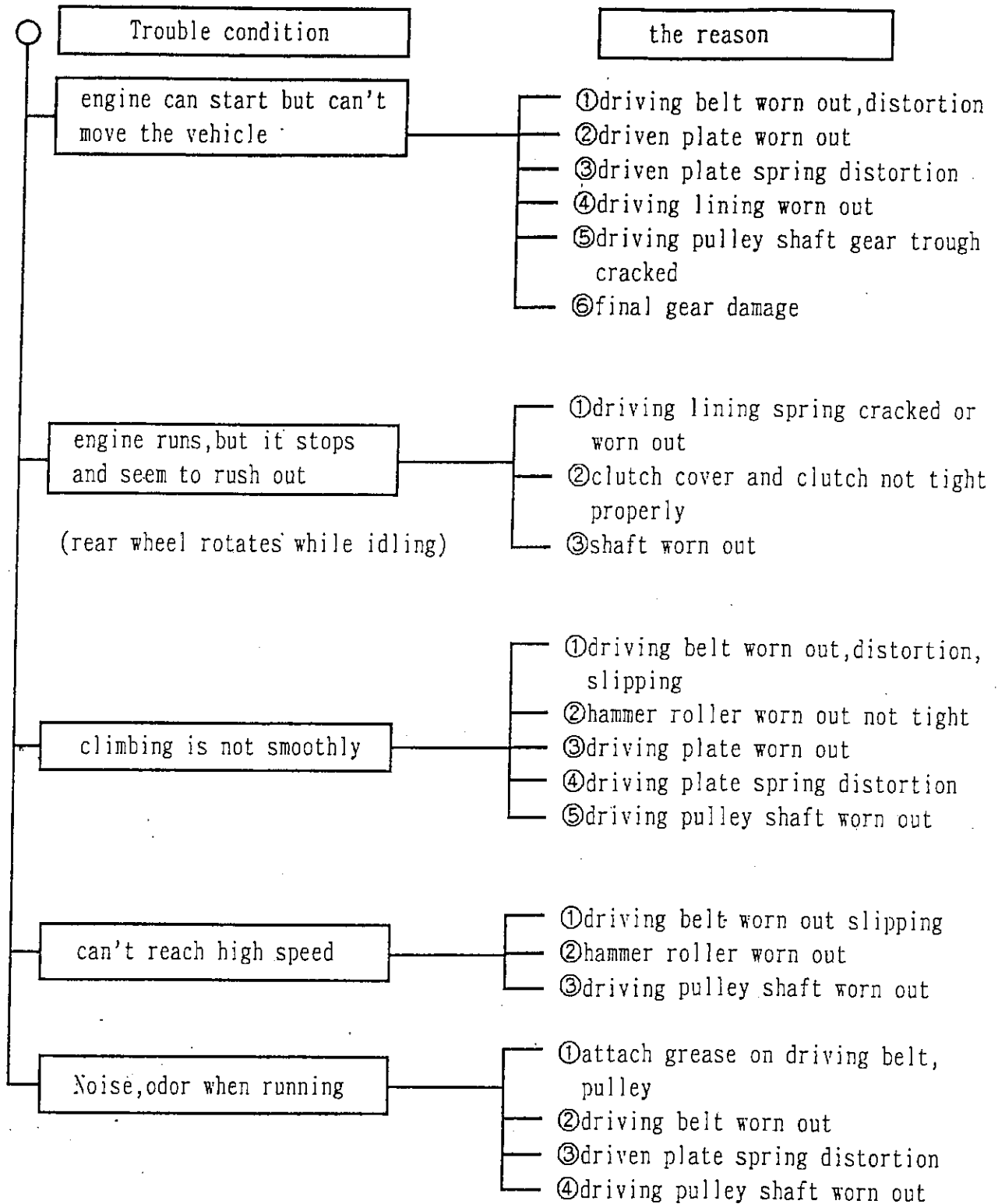

6. Handlebar steering when running.

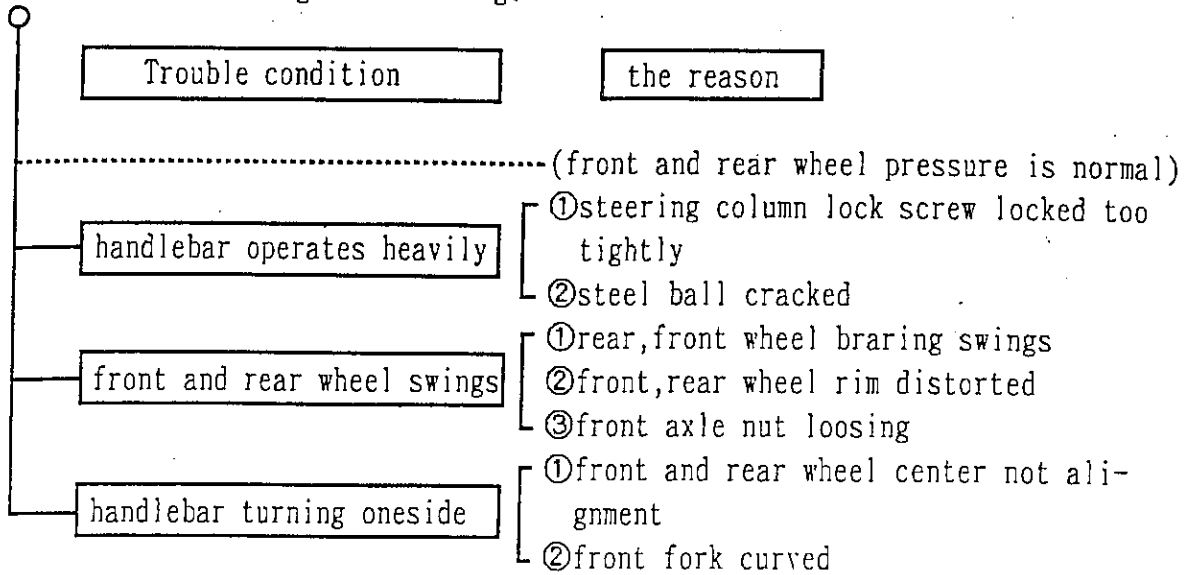

7. Front, rear damper not evenly.

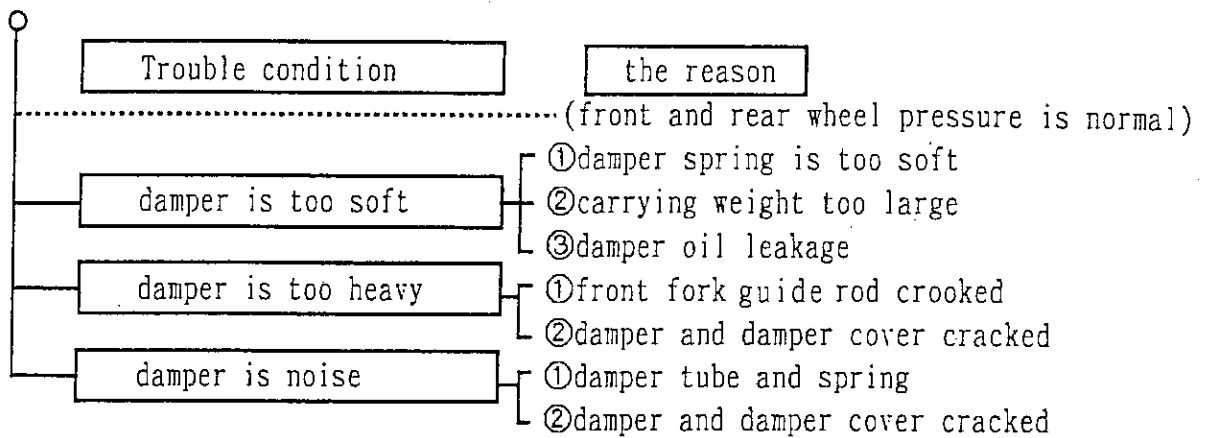

8. Brake disorder.

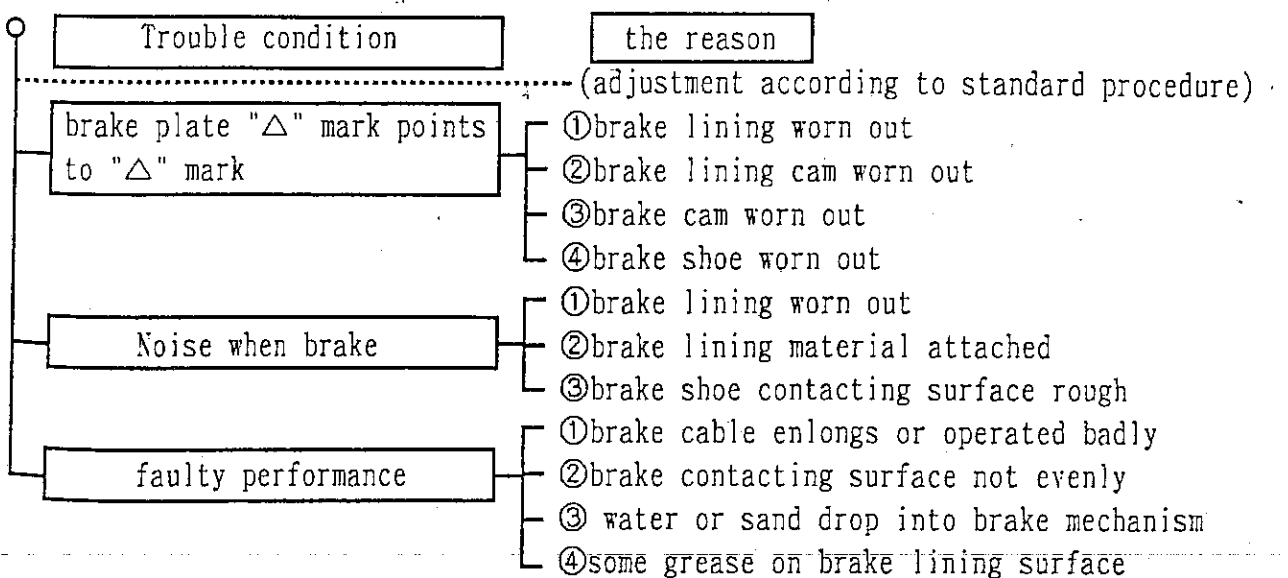

9. Oil indicator:

(a) The oil lamp doesn't light, (when the main switch is at "ON" position)

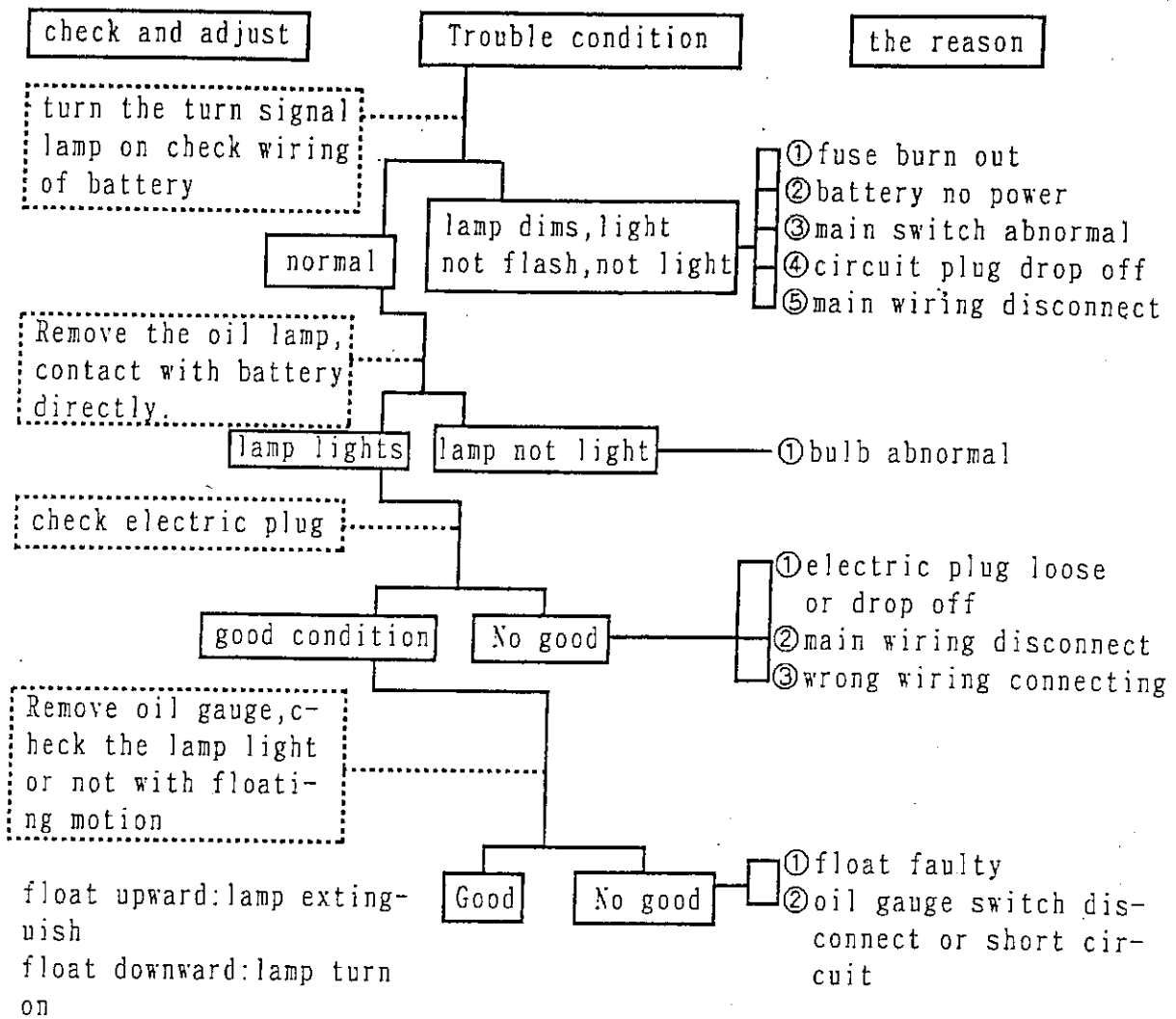

(b) Oil is enough but indicator light continuously (when the main switch is "ON")

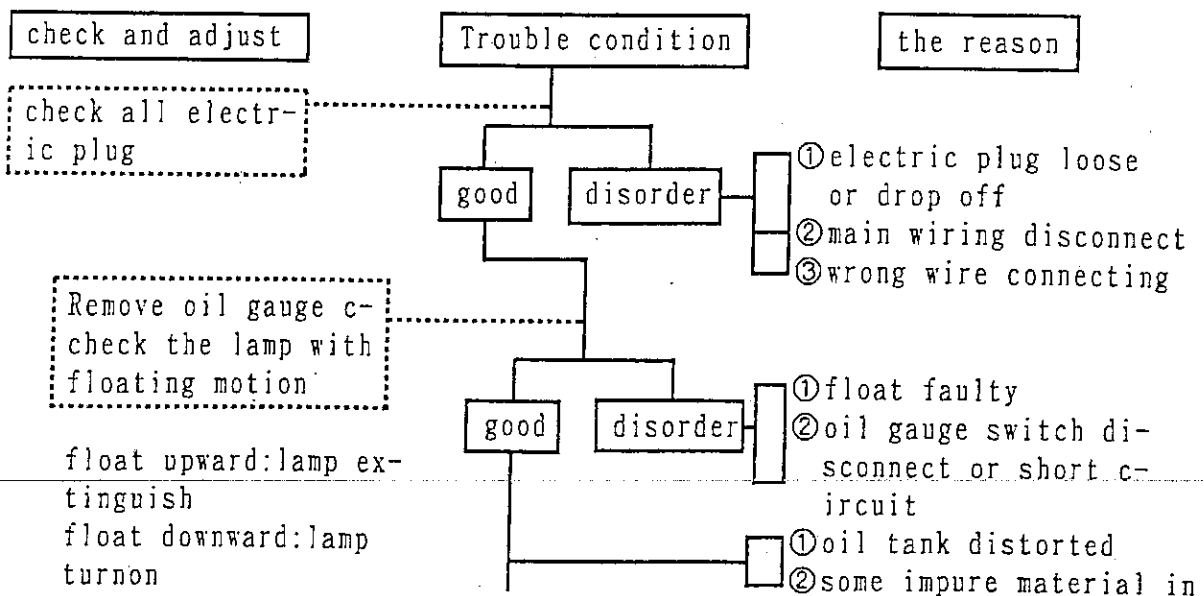

10. Fuel gauge

(a) fuel gauge indicator indicates incorrect fuel quantity (when the main switch is "ON")

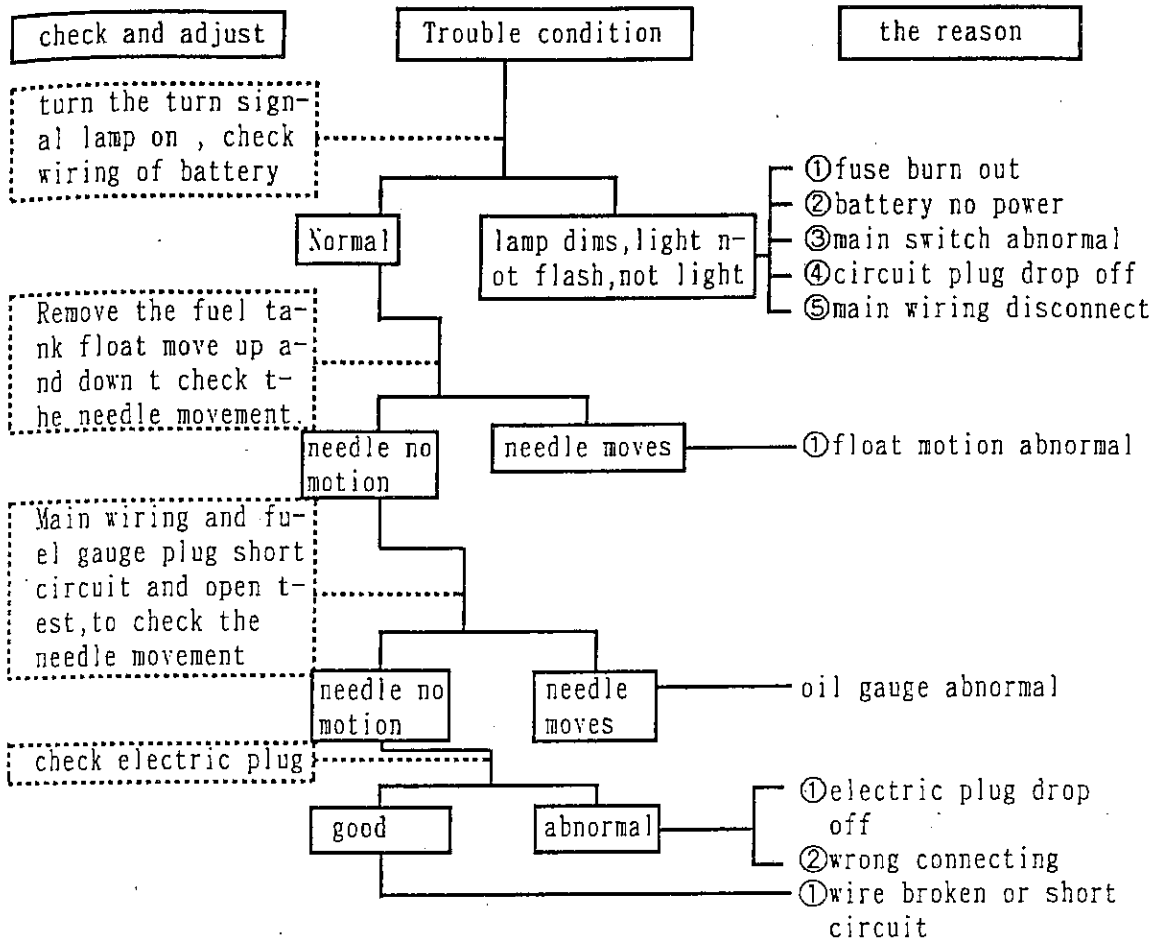

(b) fuel gauge needle not steady sometimes move up and down (when the main switch is "ON")

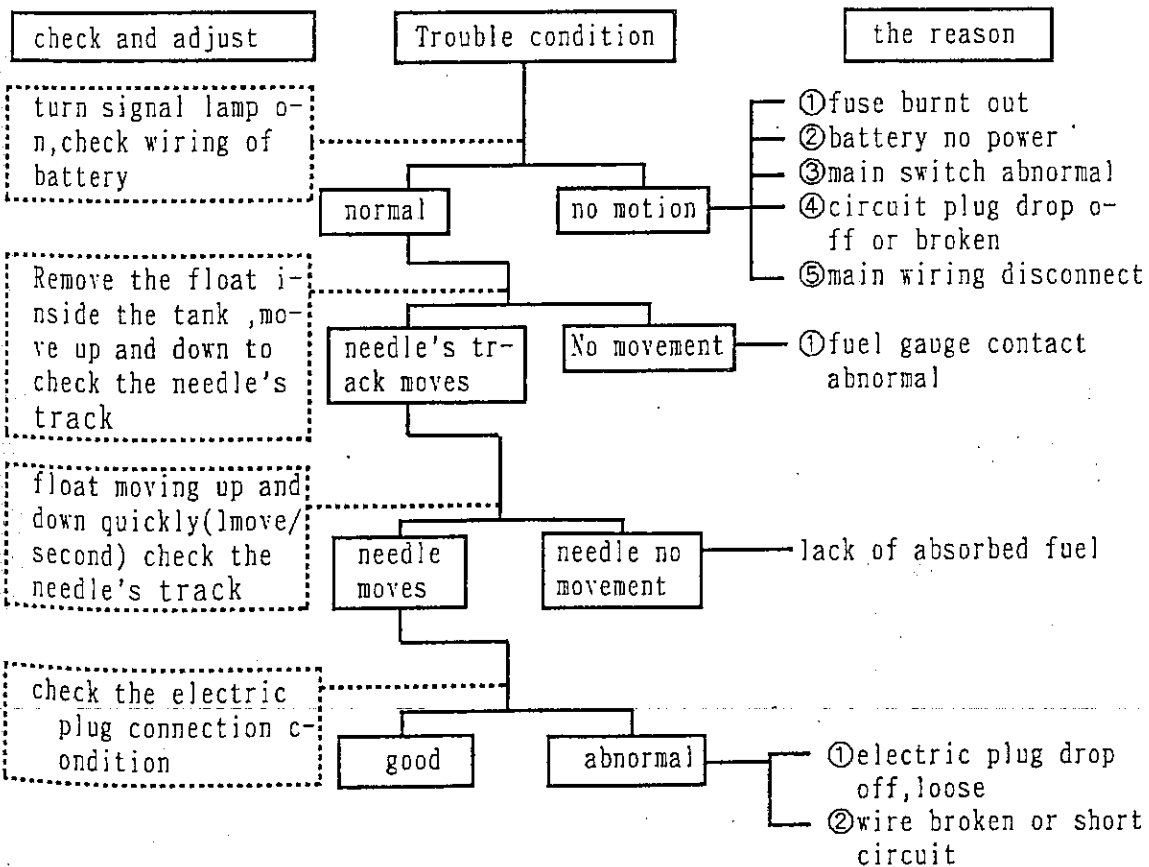

11. The starting motor

(a) starting motor no motion

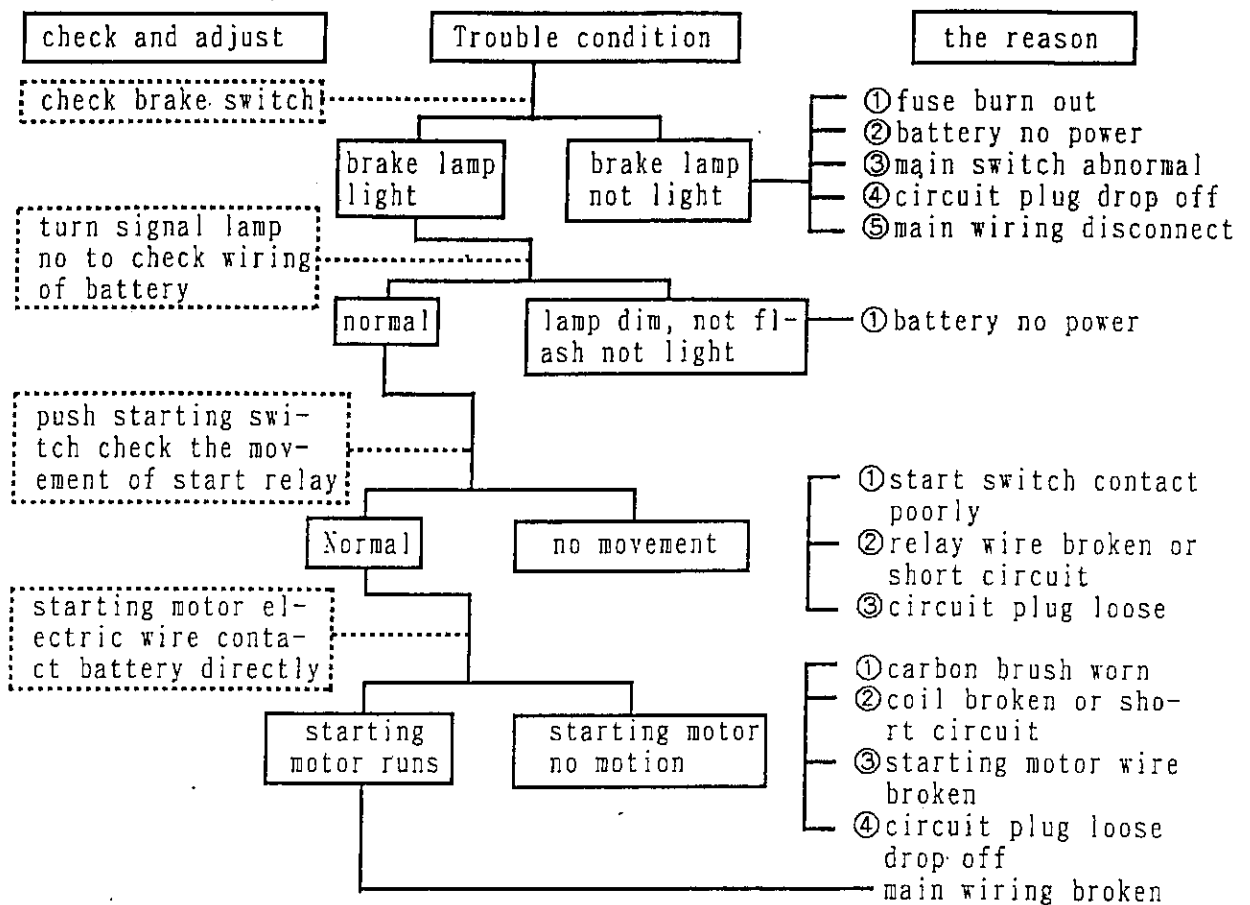

(b) starting motor running slowly or idling

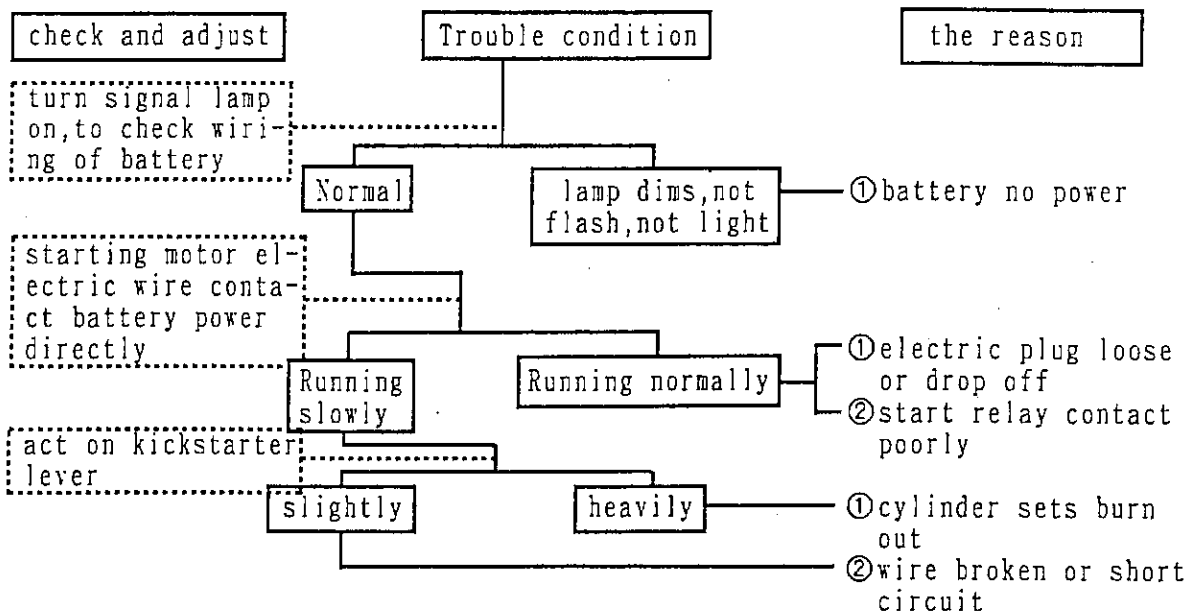

(c) starting motor running, no stopping

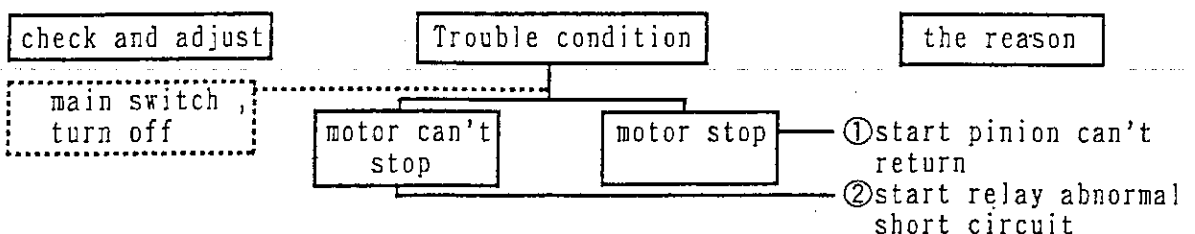

### 三、Checking and Adjustment:

- (1) Dated checking table
- (2) Battery
- (3) cleaning air cleaner
- (4) The final reducing mechanism oil
- (5) Spark plug
- (6) Compression pressure measurement
- (7) Ignition timing
- (8) Throttle cables adjustment
- (9) Idle adjustment
- (10) Frt brake adjustment
- (11) Rr brake adjustment
- (12) Tire



(1) Dated checking table:

1. [○] mark indicates periodical checking

2. [\*] indicates changing the parts

check	item	checking period							judgement standard	Remarks
		general checking	first month	home		office				
				per 6 months	per 12 months	per 1 months	per 3 months	per 12 months		
A Suspension steering handlebar	loose, swing	○		○	○	○	○	○		
	performance	○		○	○	○	○	○		
suspension: turning angle					○			○		
front fork	a. cracked			○	○	○	○	○		
	b. shaft fixed condition			○	○	○	○	○		from steering column
	c. shaft: loose				○			○		
B. Brake		○		○	○	○	○	○	clearance: front: 5-7 mm rear : 5-7 mm	check for steering column
brake lever	a. clearance									
	b. movement of brake	○	○	○	○	○	○	○		
brake	loose or damage		○	○	○	○	○	○		
	brake cables change								*per 2 years	
brake cam	worn out							○		
brake drum and brake shoe	a. clearance between drum and plate			○	○	○	○	○		
	b. brake shoe and brake plate worn out				○		○	○		
	c. brake drum worn and damaged				○			○	standard dia: rear: 110.0mm limit of use: rear: 111.0mm	mark to
wheel	front axle: damage or cracked							○		
	rear axle: worn or damage							○		check for axle
	wheel pressure	○	○	○	○	○	○	○	unit: kg/cm <sup>2</sup> ; ldriver front wheel rear wheel 1.30 1.50	
	wheel cracked or damage	○		○	○	○	○	○		
	wheel gap and worn	○		○	○	○	○	○	gap limit: front wheel: 0.8mm rear wheel: 0.8mm	
	wheel surface or other metals	○		○	○	○	○	○		
	axle nut screw pin tightness			○	○	○	○	○	front axle screw torque 3.0-4.0kg-m rear axle torque 8.0-10.0kg-m	Nut located
	wheel rim swingness and damage condition			○	○	○	○	○	swingness for front rear wheel rim. vertical swing: 2mm below horizontal " : 2mm below	

Check item	checking period					judgement standard	Remark			
	general checking	first month	home		office					
			per 6 months	per 12 months	per 1 months			per 3 months	per 12 months	
wheel	front bearing of axle, looseness		○	○	○	○	○			
	rear			○				○		
damper	rear damper spring cracked	○		○	○	○	○	○		
	ass'y part loose or damage			○	○	○	○	○		
	connecting part loose				○			○		
	bracket loose or damage				○			○		
	suspension	connecting part loose				○			○	
	damper	oil leakage				○		○	○	
cracked					○		○	○		
ass'y part, loose					○		○	○		
power transmission	Clutch and change speed mechanism	clutch			○	○	○	○	○	
		change gear oil leakage			○	○	○	○	○	
	supply grease	final driving gear oil change			○	○	○	○	○	※ per 2 year
electric installation	Ignition	spark plug			○	○	○	○	○	clearance:0.6~0.7mm NGK:BP7HS OR SAME SPEC
	start mechanism	starting motor pinion meshing				○		○	○	
	wiring	recharge effect			○	○	○	○	○	
	battery	electrolyte quant			○	○	○	○	○	level between "UPPER" and "LOWER"
		electrolyte S. gravity				○		○	○	when 20°C specific gravity: 1.270 - 1.290
	wire circuit	wire connecting loose or cracked			○	○	○	○	○	

check	item	checking period							judgement standard	Remark	
		general checking	first month	home		office					
				per 6 months	per 12 months	per 1 months	per 3 months	per 12 months			
engine	engine parts	performance, noise			○	○	○	○	○		
		low speed, acceleration			○	○	○	○	○	idling: 1900 ± 100 rpm	
		exhaustion	○		○	○	○	○	○		check t color of hausting
		air cleaner			○	○	○	○	○		
		cylinder, cylinder head inlet pipe, locking condition							○	locking torque cylinder head: (cold) 1.0-1.2kg/m inlet pipe: (cold) 1.0-1.2kg/m	
		compression pressure				○			○	using stating motor. 7kg/cm <sup>2</sup> (500rpm)	
	lubrication system	oil leakage			○	○	○	○	○		
		oil quantity, dirty			○	○	○	○	○		
		oil quantity	○								
		oil cleaner blocked				○		○	○		
	fuel syst-	fuel quantity	○								
		fuel leakage			○	○	○	○	○		
		carburetor parts dirty			○	○	○	○	○		
carburetor throttle and choke performance				○	○	○	○	○			
carburetor float height				○	○	○	○	○			
carburetor adjustment				○	○	○	○	○			
fuel pipe changing									※ per 4 years		

Checking item		checking period							Judgement standard	Remark
		general checking	first month	home		office				
				per 6 months	per 12 months	per 1 months	per 3 months	per 12 months		
lamp system	performance	○		○	○	○	○	○		
	dirty, cracked	○		○	○	○	○	○		
horn turn signal reflector	performance	○		○	○	○	○	○		horn turn signal
lock	performance			○	○	○	○	○		
rear view mirror	check the illumination	○		○	○	○	○	○		
blinker license plate number & mark	dirty cracked	○								
Instrument board	performance	○		○	○	○	○	○		
muffler	Ass'y part loose cracked			○	○	○	○	○		
silencer	performance				○		○	○		
chassis	loose or cracked				○		○	○		
the earlier abnormal condition	confirm it does not happen again	○								
others	chassis lubrication			○	○	○	○	○		
	decoking mixer, muffler, silencer				○			○		

## (2) Battery: Recharge when run out of it

1. Open the cover and remove the rubber cap. → take out the battery.
2. Remove the negative cable and then the positive cable, → take out the battery to recharge.
3. Re-assembling the battery as the opposite procedure of disassembling after recharging.

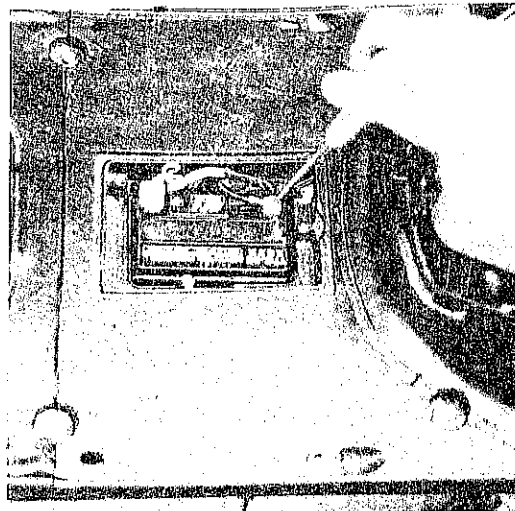
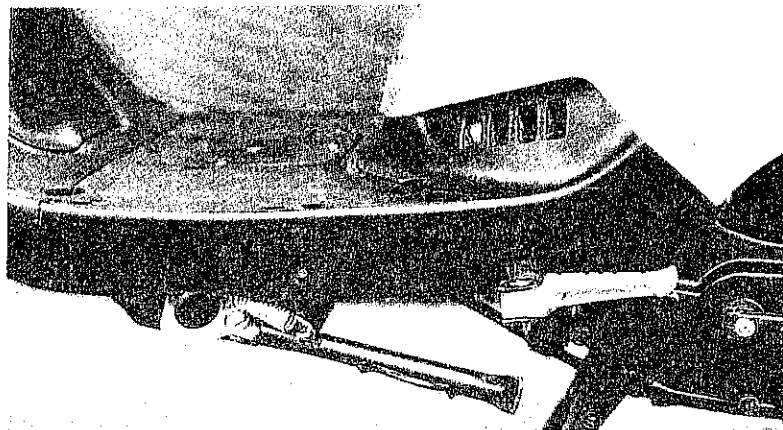

### Note:

- A. Do not take out the sealed bolt when recharging.
  - B. Without refilling water for the battery.
- Please recharging (12V) as the following current.  
Time standard:  $0.4A \times 5-10$  hr or rapid:  $4A \times 30$  min.

### (3) Cleaning air cleaner

1. Remove air cleaner cover with cross type screwdriver.
2. Take out the sponge of air cleaner.
3. Immersed in neat oil then pinch it dry.
4. Assemble the air cleaner as the opposite above procedure.

Note: Do not start the engine before assembling the air cleaner.

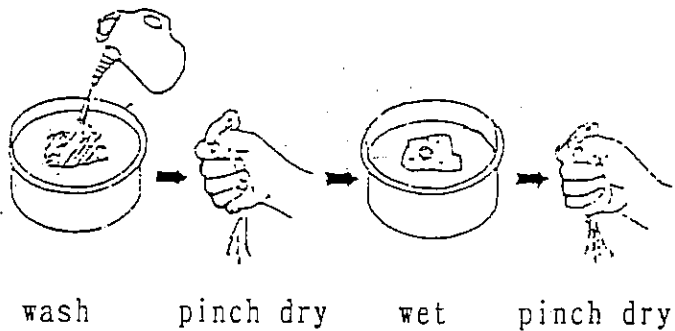
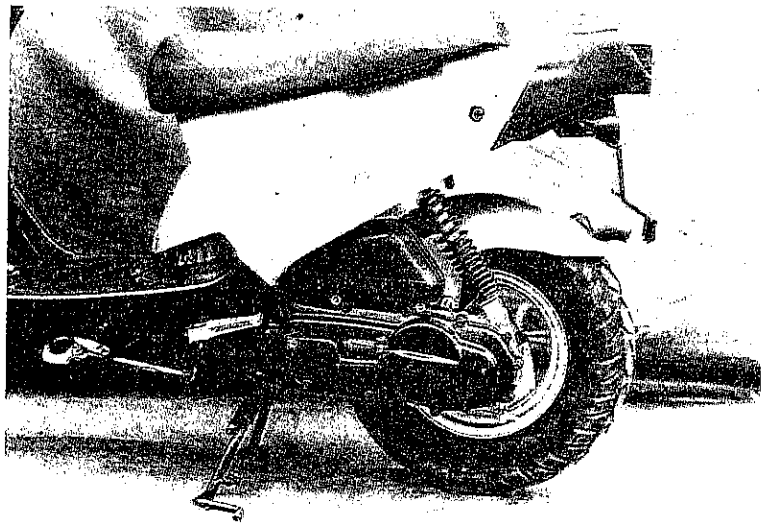

### (4) The final reducing mechanism oil

1. Change the oil in the gear box:
  - a. Turn off the engine after warm up.
  - b. Put a bowl under the engine.
  - c. Remove the draining bolt and filler bolt to drain the gear oil off.
  - d. Lock the draining bolt before refill 0.7l gear oil and then lock the filler bolt.
  - e. Locking torque: 1.8 kg.m

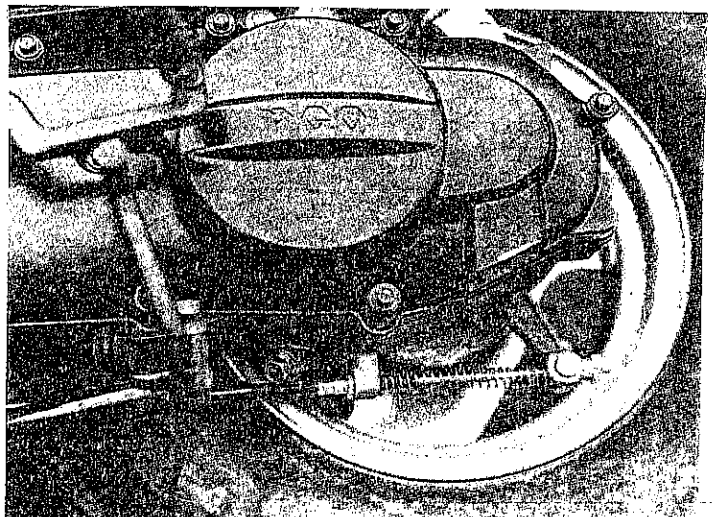

## (5) Spark plug

Remove spark plug

Check the spark plug electrode

Burnt out or not and carbonized or not

Clean the electrode, if it is dirty

Spark plug specification

NGK: BP7HS or same spec.

Gap of spark plug: 0.6~0.7mm

spark plug

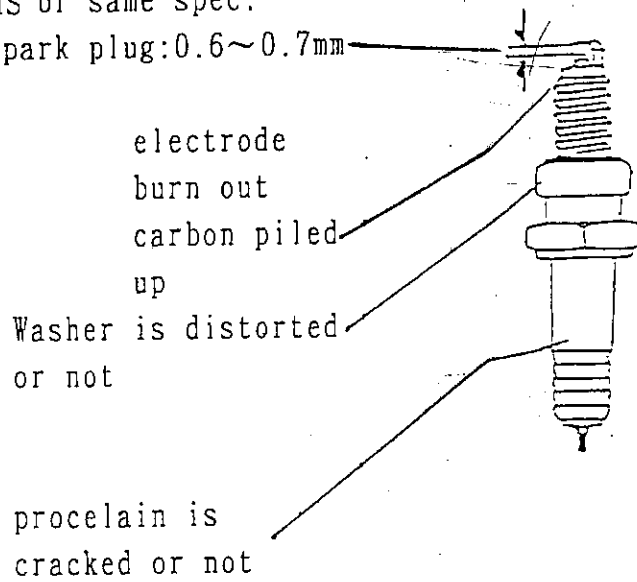

## (6) Compression pressure measurement:

1. Measure it when the engine is warm.
2. Remove the cover.
3. Remove spark plug then place compression pressure gauge.

Fully open the throttle, act on kickstarter 5 times continuously, measure the compression pressure.

Compression pressure:  
6 kg/cm<sup>2</sup>-600rpm.

When the compression pressure is too low, check the following:  
a. cylinder head washer cracked.

b. piston cylinder worn out.

c. piston ring worn out.

The compression pressure is too high it is due to carbonization of combustion chamber and piston tip.

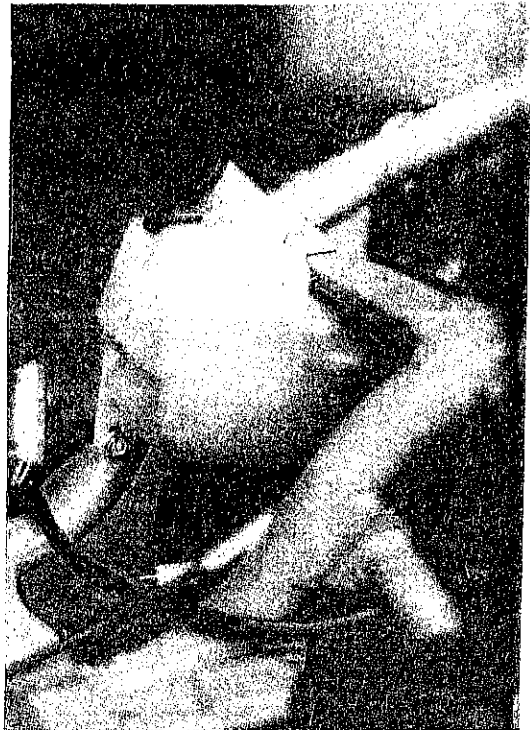

## (7) Ignition timing:

Don't adjust the ignition timing because of using the CDI sets.  
If ignition timing is not correct check the CDI sets AC magneto, change it if it is abnormal.

checking ignition timing:

1. Remove right side cover.
2. Remove the fan cover.

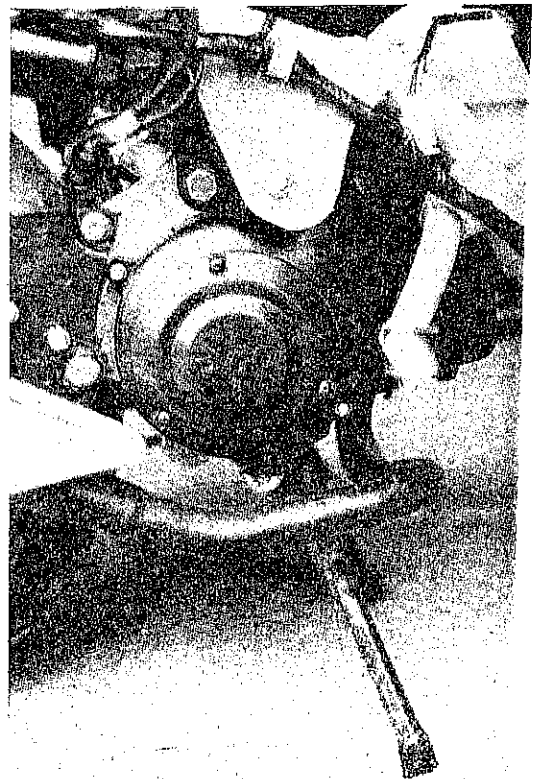



3. Remove fan case.
4. Check with ignition timing lamp.  
Keep the engine running at  $1,900 \pm 100$  r.p.m  
if the checking mark lay in  
 $\pm 3^\circ$  apart from F, It's ok.
5. Ignition timing: B.T.D.C.  
 $17^\circ \pm 3^\circ / 1900$  rpm.

### (8) Throttle cables adjustment:

Check the clearance of throttle  
twist grip.

Normal clearance: 1.5-3.5mm

Adjust it by rotating the  
adjuster nut, change it if the  
throttle cables can't be adjusted.

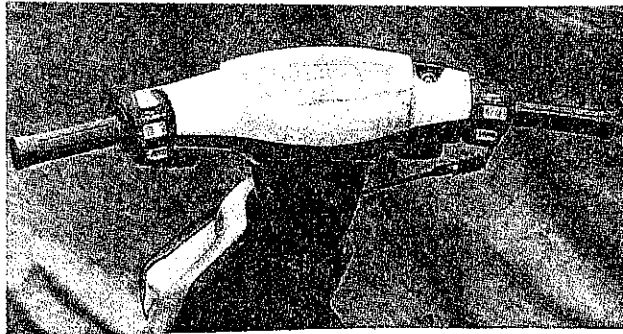

## (9) Idle adjustment:

Note: adjust it when the engine is warm.

Remove left side cover.

Use Tachometer

Adjust throttle valve screw in order to set the idle running at  $1900 \pm 100$  rpm.

If the rpm not steady when slightly open throttle twist grip, adjust according to the following:

1. Screw the air adjuster screw inside, (cw) then loosen it oppositely (ccw) recommended opening:  $1\frac{3}{4} \times \frac{1}{2}$  circle from dead point.
2. Rotate the throttle valve screw to set the idling condition.
3. Rotate air adjuster screw cw and ccw to find the highest rotation location.
4. then rotate the throttle, valve screw to set the idling condition.
5. Gradually open the throttle, adjust it continuously till the idle running rpm is steady.

If the rpm is unsteady, please adjust it repeatedly according to procedure 2-4

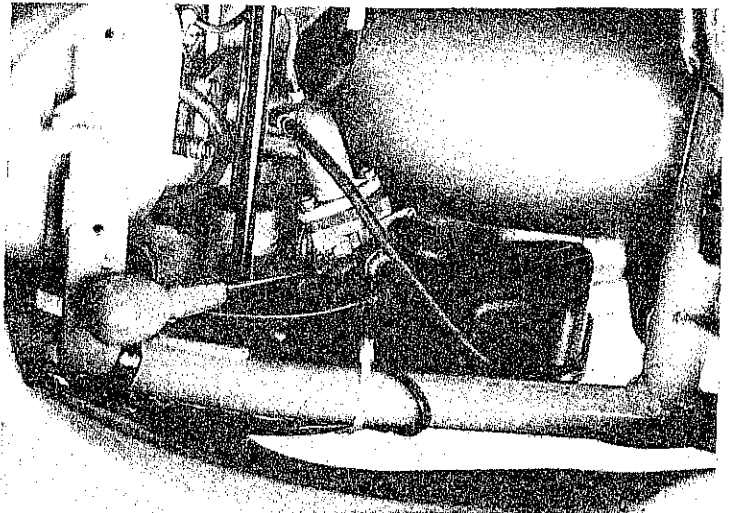
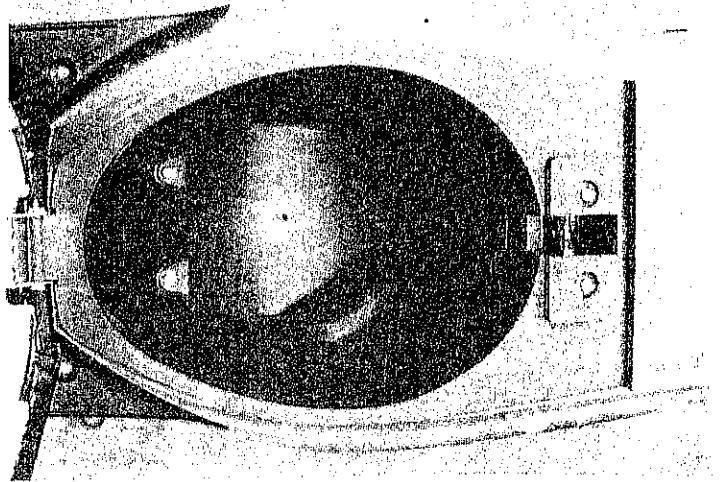

## (10)Front brake adjustment:

1. Check the clearance of front brake lever.

clearance: 2-5mm

2. If the clearance is beyond standard: check whether

a. The air mix into the pipe/pump

b. The brake oil pressure system leaking.

Note:

Try brake lever to see if it is loose, check brake oil and air mixture in oil pipe, which reduces or damages brake efficiency.

3. Check the brake oil:

a. Refill the brake oil when the oil surface lower than the "LOWER" level

b. Specification of oil SAEJ-1703F-DOT3&DOT4

Note:

a. To prevent the splitting oil onto the parts and clothing put a piece of cloth on the bottom at refilling.

b. To avoid letting in water or particles to the main cylinder at refilling.

c. Never use oil of different spec.

d. In case that skin, eyes or clothes touch the brake oil please washed with large quantity water, then cured by special doctor immediately.

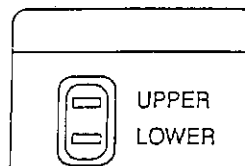
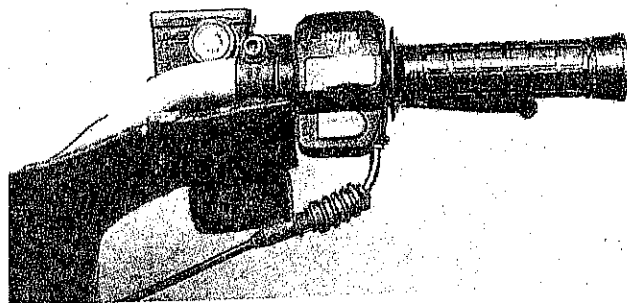
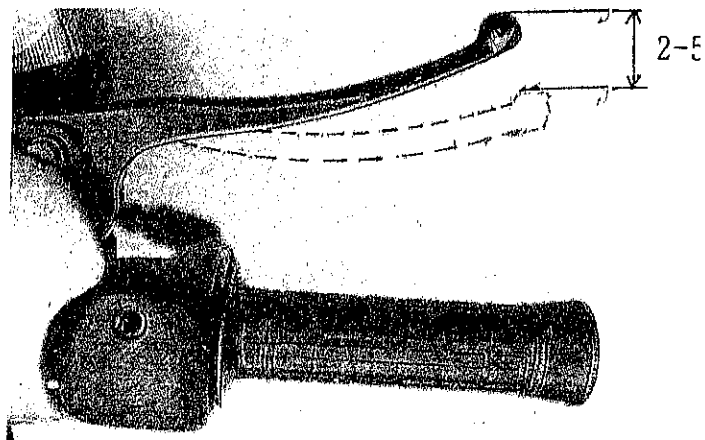

## (11)Rear brake adjustment

Check the clearance  
of rear brake lever.

Clearance:5-7mm

If the clearance is  
beyond the above sta-  
ndard,adjust it by  
rotating the adjuster  
nut.

- a.Lefthanded rotation  
add the clearance.
- b.Righthanded rotation  
reduce the clearance.

Note:

When the arrow of rear  
brake indicator lay in  
the arrow of left crank-  
case,change the brake  
lining.

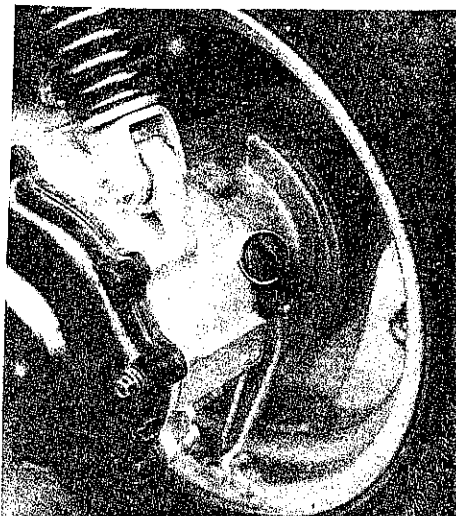
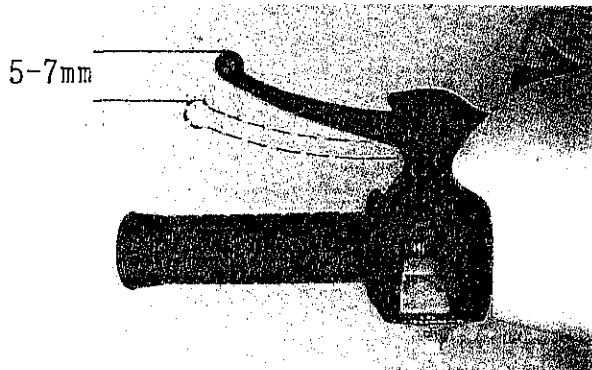

## (12)Wheel:

1. Check the wheel pressure  
Notice:

check the wheel before  
running

2. Wheel pressure:  
front wheel: 1.30kg/cm<sup>2</sup>  
rear wheel: 1.50kg/cm<sup>2</sup>
3. Wheel dimension:  
front wheel: 120/90-10  
rear wheel: 130/90-10
4. Check is there any impure  
object in the wheel gap.
5. Check the depth of wheel  
stripe  
a. Depth(front & rear):  
According to mark of tyre  
"▲" indicateing change  
new tyre

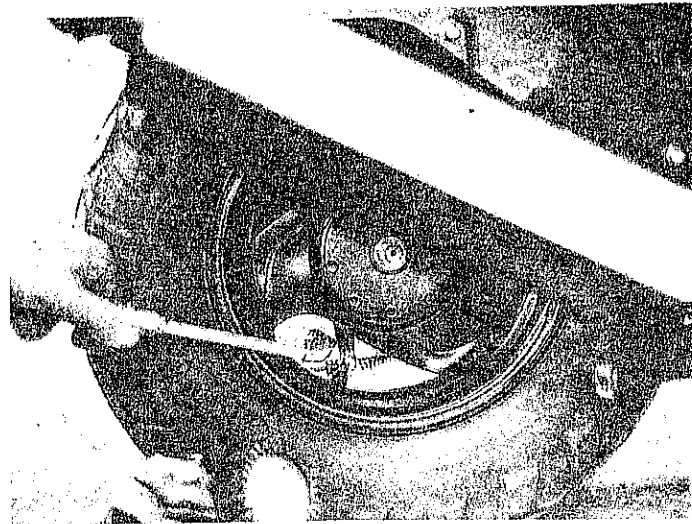
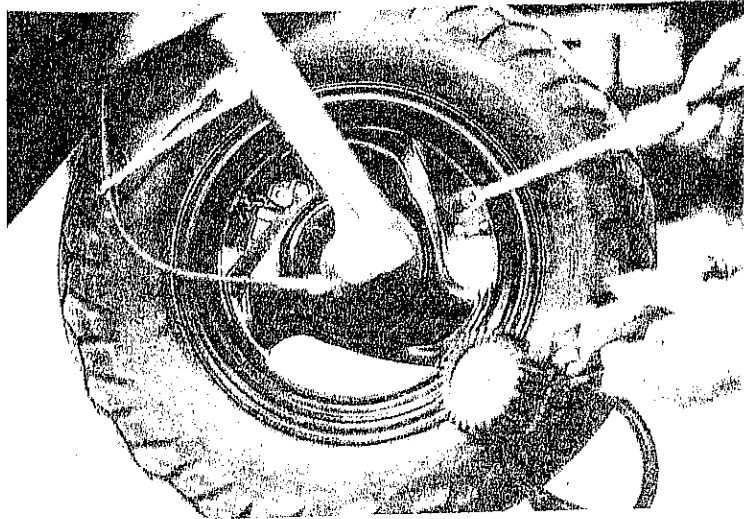

### Note:

1. Check and adjust the wheel pressure  
at it is too low . Adjusting the  
pressure according to the carrier \\  
driver \\  
passenger \\  
accessories and  
cruise speed.
2. Proper loading is very important for  
handling \\  
riding \\  
braking \\  
performance  
and safety. Can not load any unfasten  
parcel. Loading the weighties parcel on  
the central of vehicle, balancing on  
the both side.  
Adjust proper load and check the wheel  
pressure. The total weight of carrier  
driver \\  
passenger and accessories can  
not overload than the limit of approved  
weight. Operating the overload vehicle is  
easy to cause wheel damage and accident.

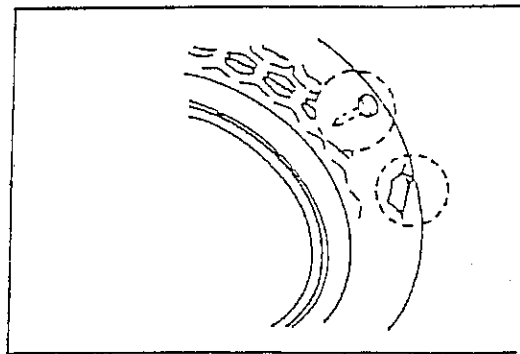

#### 四、Dismantling, maintaining, repairing and assembling operation:

- (1) Lubrication system
- (2) Engine dismantling
- (3) Cylinder head, cylinder, piston
- (4) AC Alternator flywheel magneto
- (5) Drive pulley, starter, clutch, driven pulley
- (6) Final transmission mechanism
- (7) Crankcase, crank shaft
- (8) Carburetor
- (9) Chassis cover
- (10) Steering column, front wheel, front damper, front fork
- (11) Rear wheel, rear brake, rear damper
- (12) Fuel tank, oil tank

## (1) Lubrication system:

- 1.lubrication system diagram.
- 2.troubleshooting.
- 3.removing oil pump.
- 4.checking oil pump.
- 5.assembling oil pump.
- 6.releasing air in the oil pump.

1.Lubrication system diagram

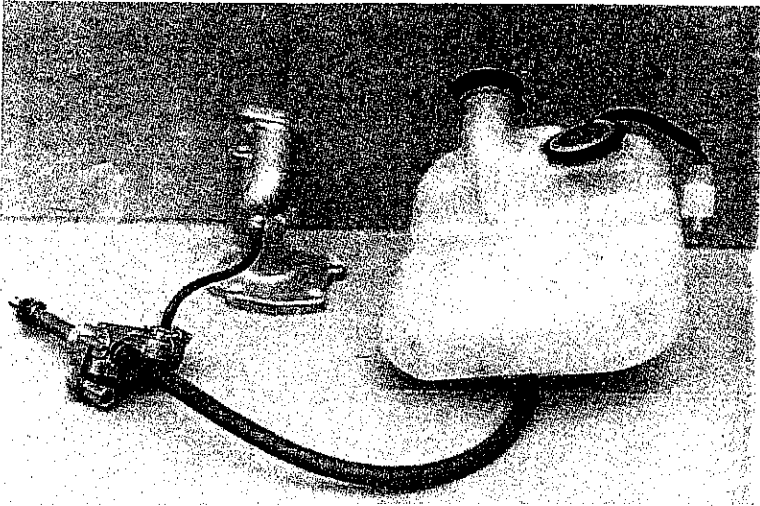



## 2. Troubleshooting.

- A. The exhaust with too much white fume, carbon collected in spark plug:
  - a. the adjustment of oil pump is not proper. (too much oil)
  - b. the quality of oil is not good.
- B. Engine overheating:
  - a. the adjustment of oil pump is not proper. (lack of oil)
  - b. the quality of lubrication oil is not good.
- C. Piston seize
  - a. the adjustment of oil pump is not proper, or pipe is blocked.
  - b. there is air in the oil pump system.
  - c. oil pump is out of order.
- D. The oil pipe from oil tank to oil pump is blocked.
  - a. the air hole of oil tank cover is blocked.
  - b. the oil tank filter net is blocked.

- Notice:
- 1. When removing the oil pump, do not drop any object unexpected to the oil pipe.
  - 2. If there is air in oil pipe, release it.
  - 3. Oil pump locking torque: 0.8-1.2kg-m.

### 3. Removing oil pump.

Removing when the oil pump and crank case outer is clean.

- a. Remove the luggage and rear bracket.
- b. Remove the input/output oil pipe.
- c. Remove control cables of oil pump.

Take out the oil pump by removing the locking screw on oil pump.



### 4. Checking oil pump.

Removing oil pump and check:

- a. O-ring is distorted or not.
- b. contact part of crankcase is injured or not.
- c. Oil pump body is injured or not.
- d. the movement of control lever is free or not.
- e. the gears are injured or not.
- f. check seal is oil leakage or not.

Avoid dividing the oil pump into part; It won't work if it is divided into part.

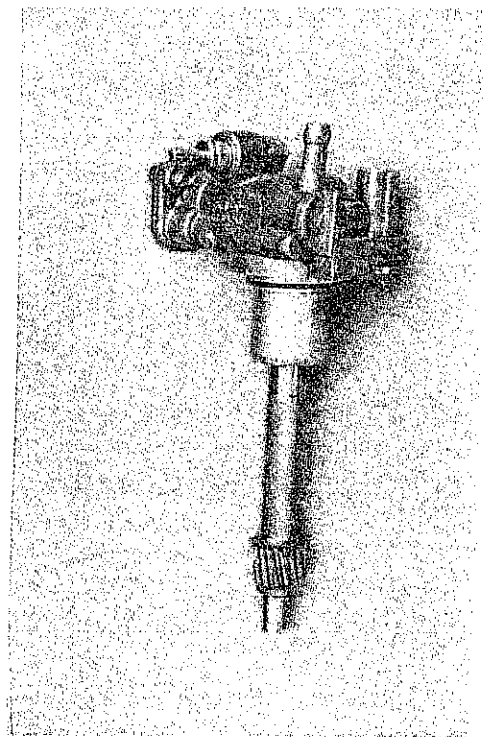

5. Assembling the oil pump

- a. Assemble the oil pump as the opposite above procedure.

O-ring of oil pump should lubricated by grease of oil, then place on crankcase.

The contact part of oil pump and crankcase should be assembled firmly avoid shew assembly

The gears of oil pump should be lubricated by grease.

- b. Oil pump screw should be tighten definitely.

After assmebling, checking the following:

- a. the adjustment of control cables.  
b. Is there air in oil pipe.  
c. the oil leakage at any location.

6. Releasing air in the oil pump.

- a. If there is air existed in oil pipe, it will cause engine lubrication trouble.  
b. releasing air operation is oil pipe and oil pump releasing air, so firstly release air of oil pipe.

Pour specific amount of oil to oil tank.

Place dry cloth under th oil pump.

Remove oil pipe.

Use grease injector, pour oil to oil pump inlet pipe part, let it full of oil, and let oil pipe full of oil, then put it in oil pump. After assembling, check definitely the air is in oil pipe or not.

## (2) Dismantling & assembling of plastic parts

(1) Screwing out the 3 screws of front windshield → take off the front protector.

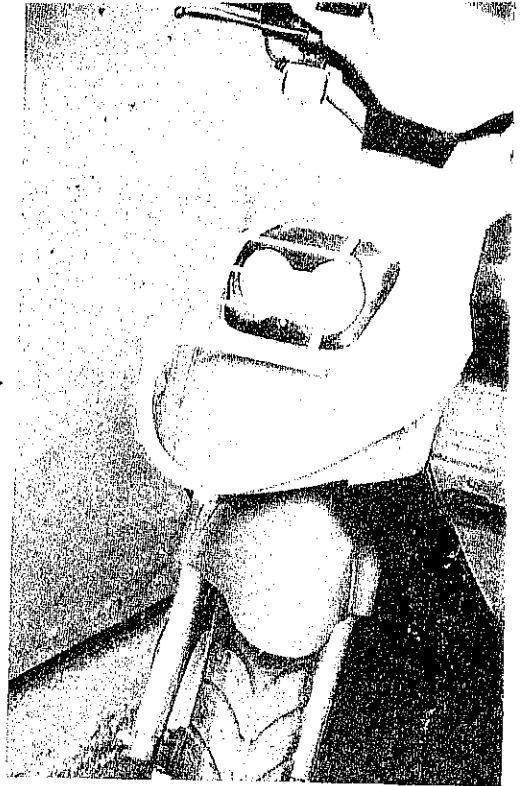

(2) Screwing out the 5 screws of windshield & front inner cover. → take off the windshield.



(3) Screwing out the 4 screws of the rear protector & body cover → take off the rear protector.

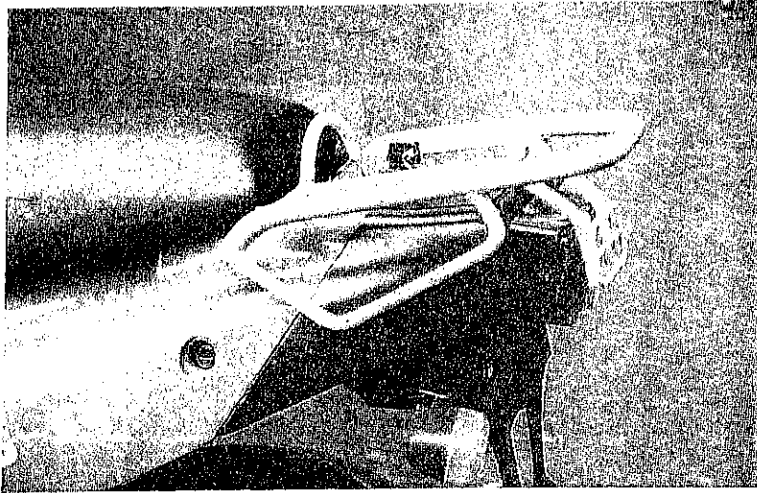

(4) screwing out the each 2 screws of right & left strips.

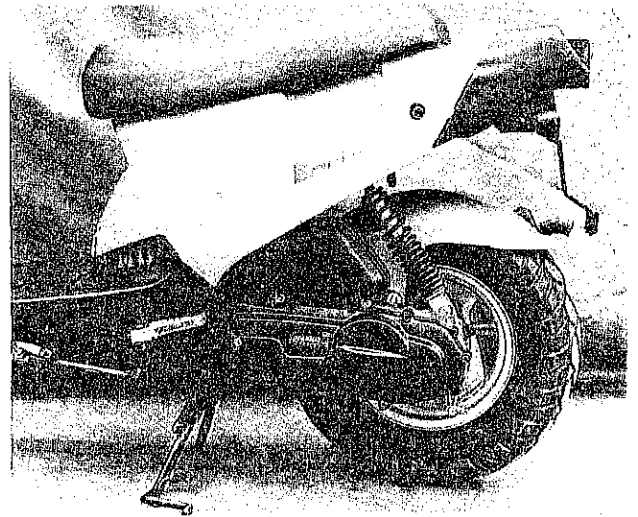

(5) Take off the right & left strips.

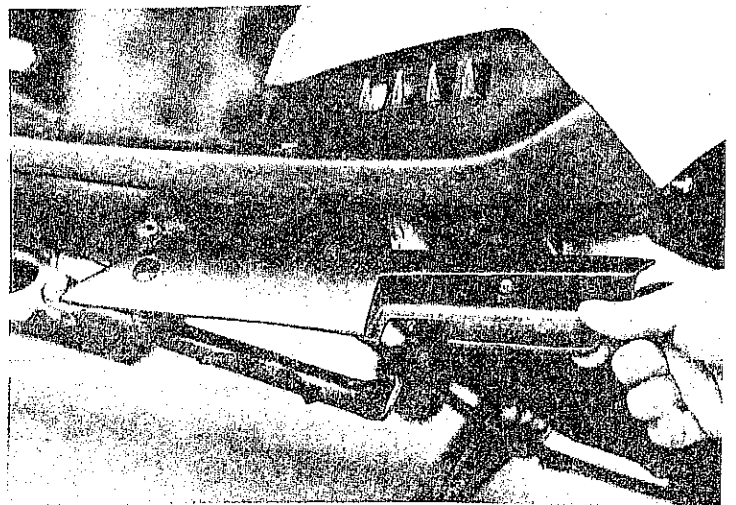

(6) Open the seat, screwing out the 4 screws of the luggage box. → take out the luggage box.

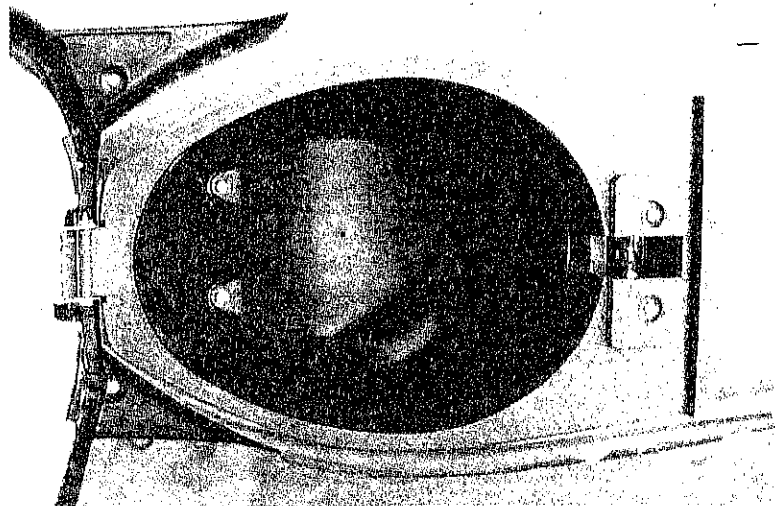

(7) Remove the screws of side cover and front cover → take off the front cover

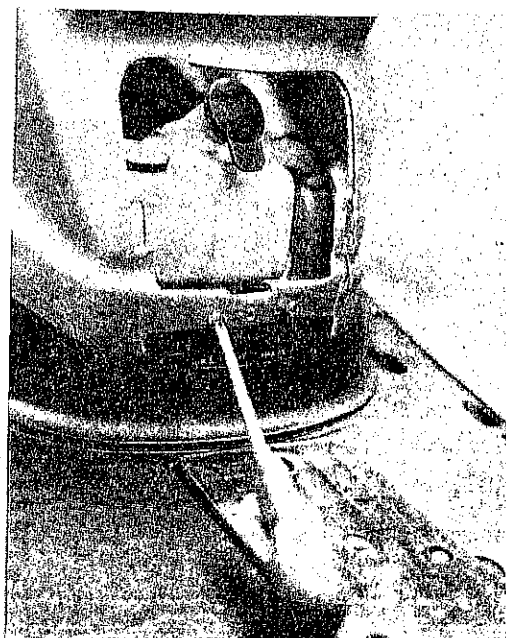
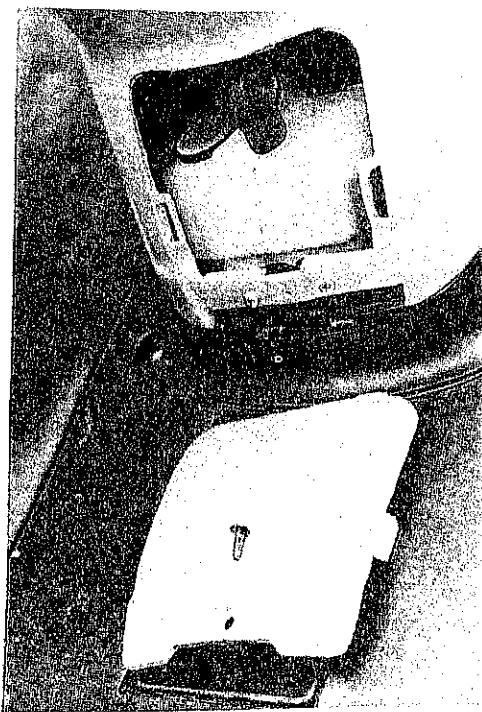

(8) Remove the 2 screws of side cover.

(9) Open fuel tank, and take out → remove the 2 screws of the side cover.

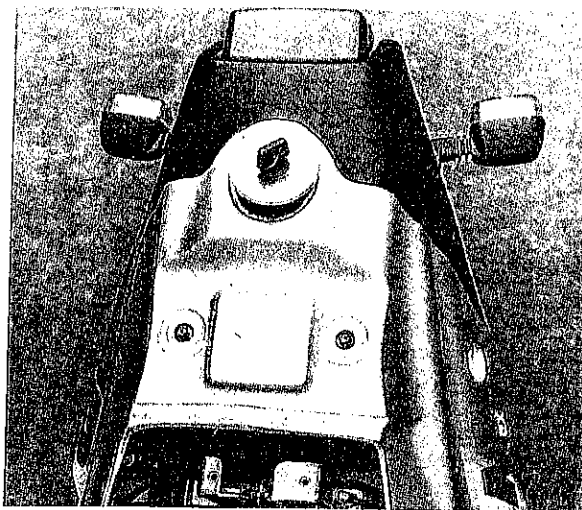

(10) Remove the right & left screws of side cover → take off the side cover.

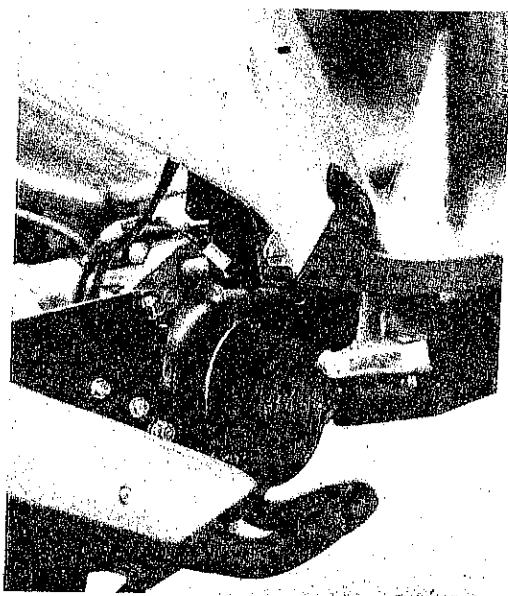

(11) Remove the step floor & the 3 screws of the cover of battery → take off the cover.

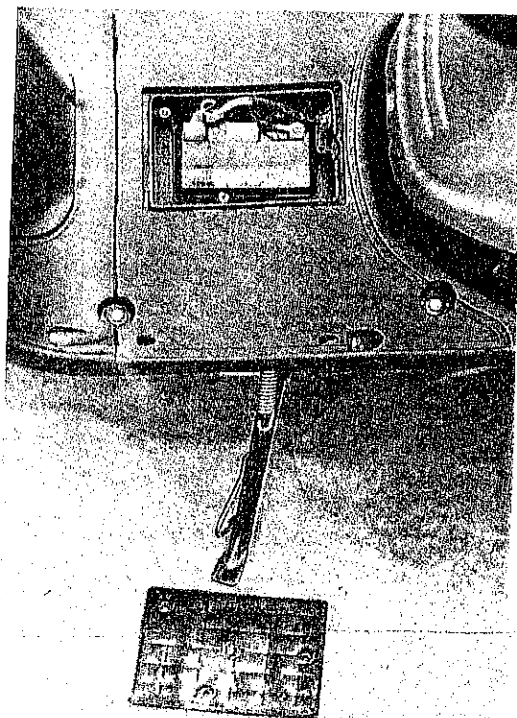

(12) Remove the battery → negative first then positive (B) remove the screws of the fender → take off the fender.

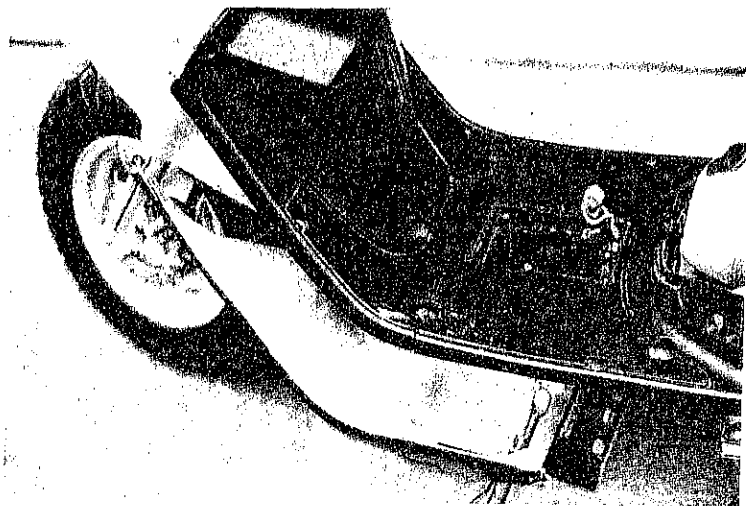

(13) Remove the 3 screws of front inner cover. → take off the front inner cover.

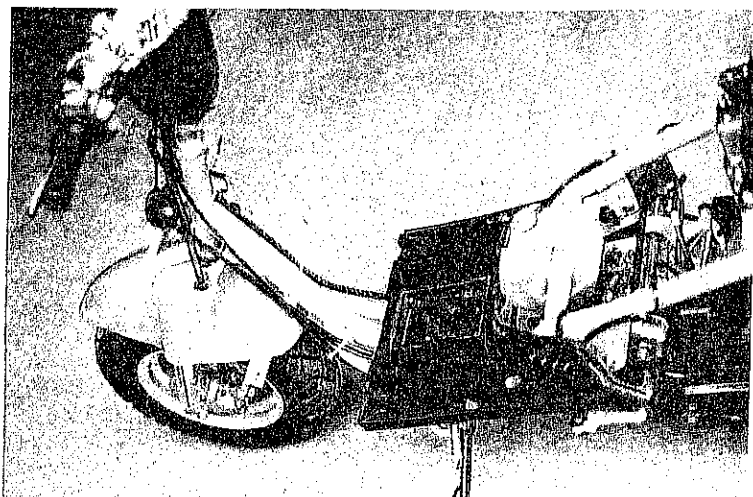

(14) Remove the 2 screws of each side rear lamp cover.

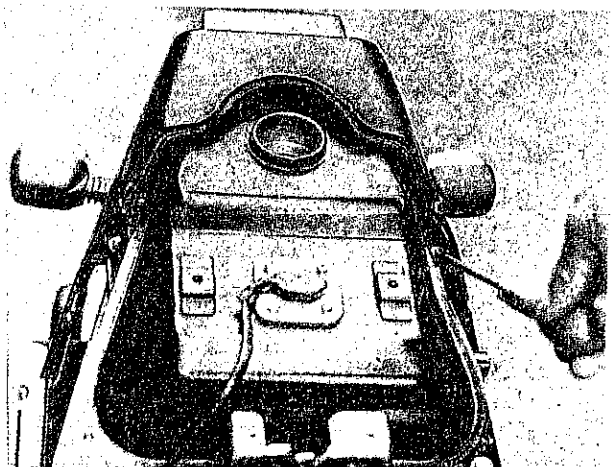



(15) Take off the rear lamp cover

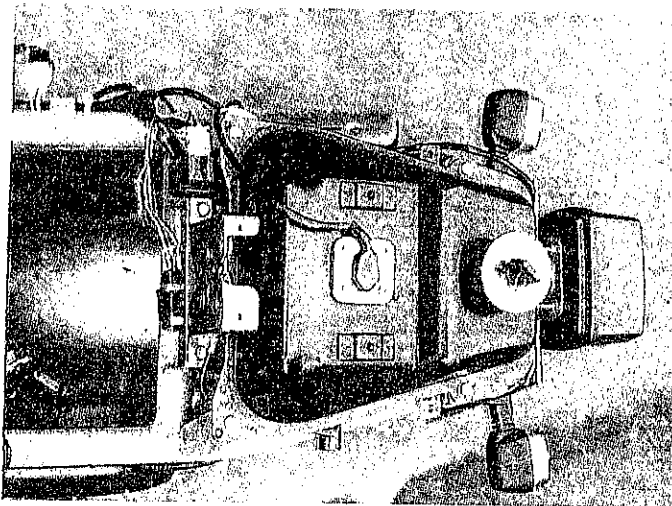

(16) Remove the 2 screws of step floor.

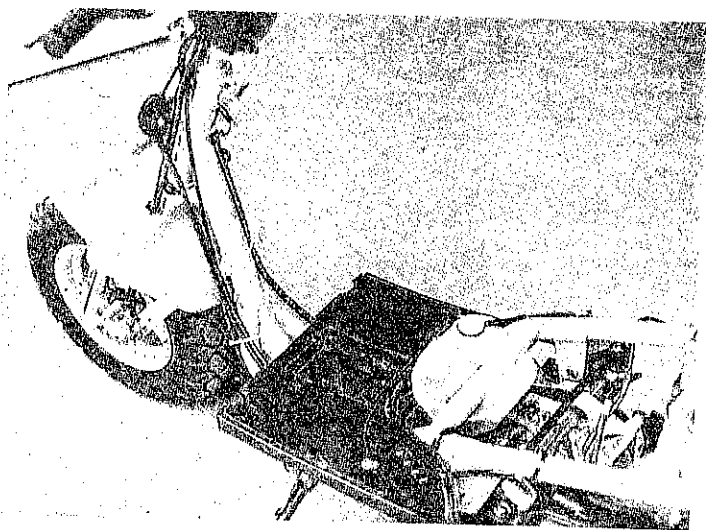

(17) Take off the step floor, re-assembling as the opposite procedure of disassembling.

locking torque: M6=0.7-1.1 kgf-m  
M5=0.35-0.5 kgf-m

Note: avoid clamping & scraping the cables or pipes by the plastic holding.

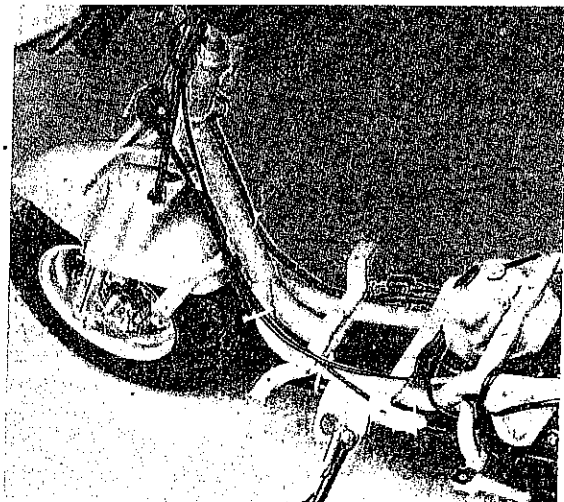

(3)Dismantling engine:

A.dismantling engine

B.Installing engine

A Dismantling engine.

1. Remove Rear bumper  
Luggage tank  
side cover

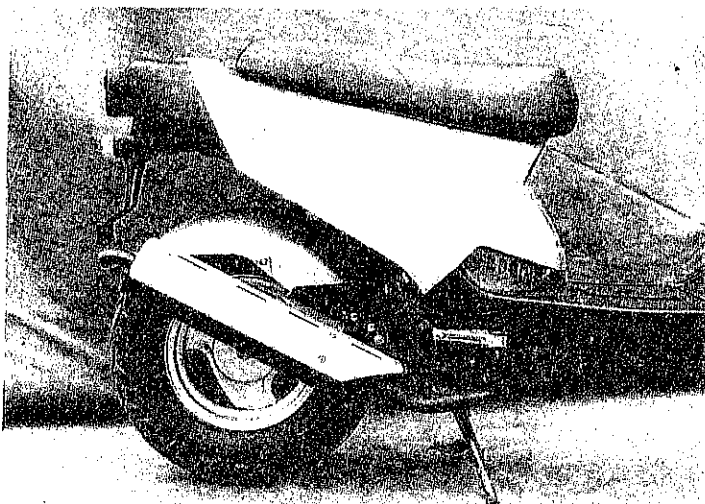

2. Remove vacuum pipe  
and fuel pipe and  
oil pipe

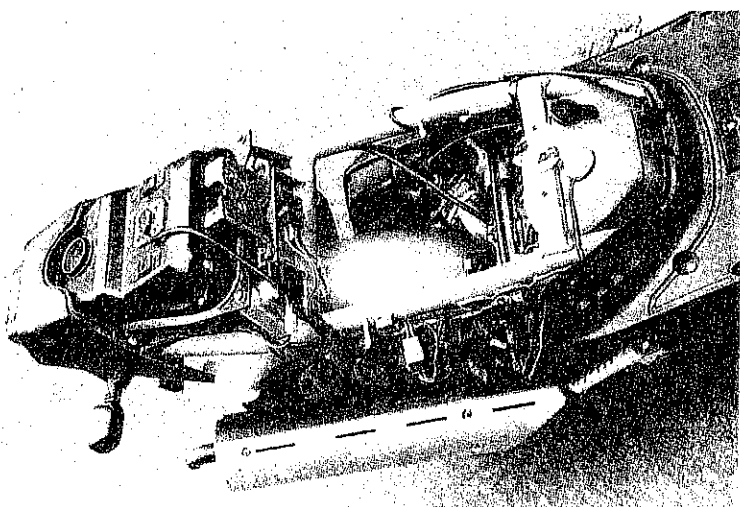

3. Remove the electric plug of  
AC magneto starting motor

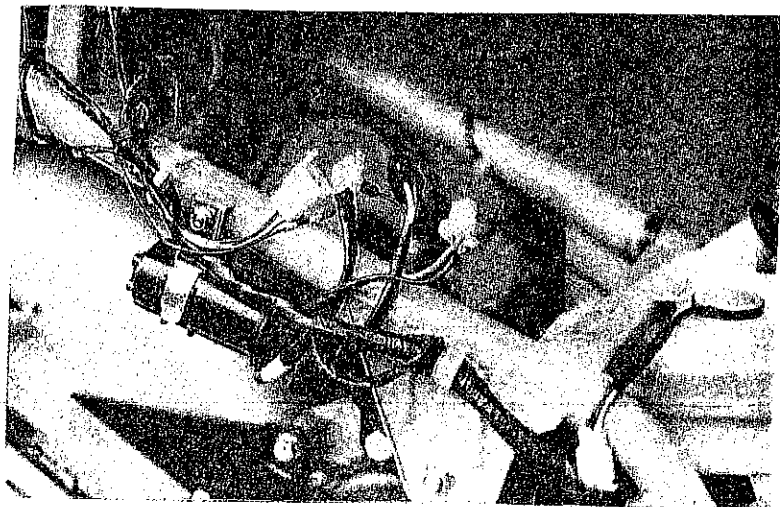

4.Remove cable of auto  
choke and carburetor

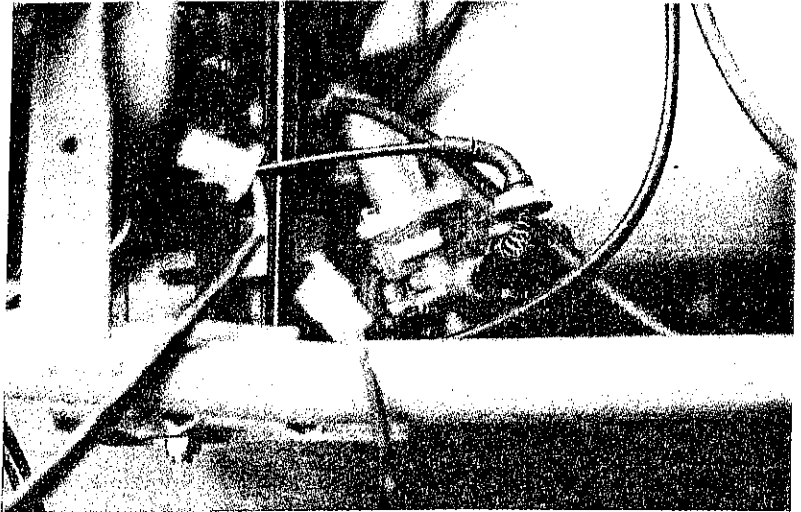

5.Remove breather pipe

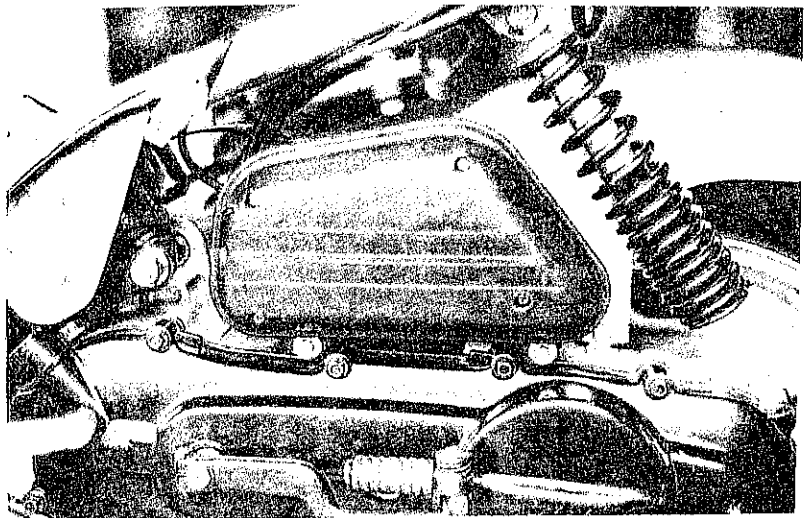

6.Remove cap of spark plug

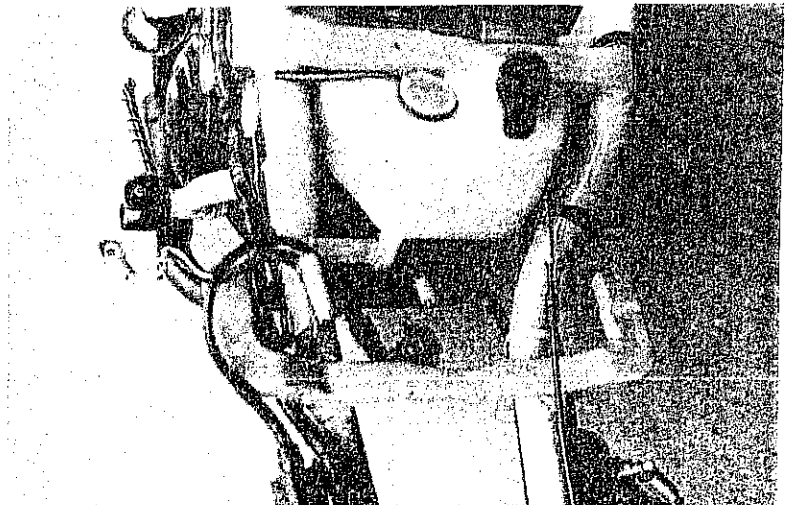

7.Remove rear damper bolt

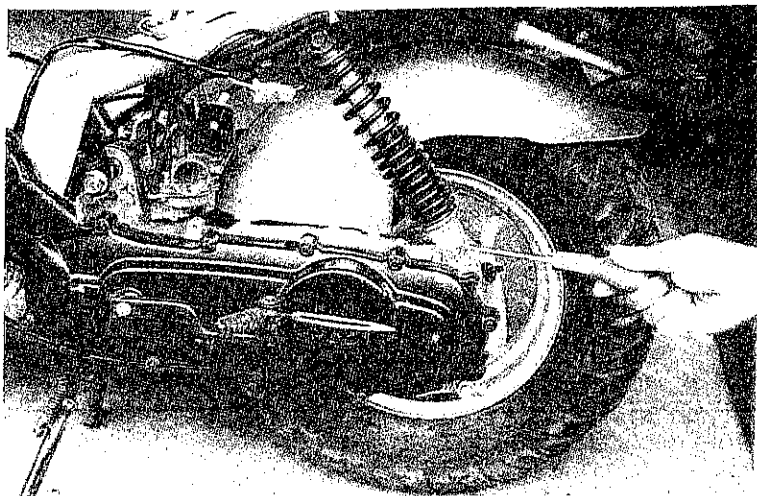

8.Remove engine suspension nut

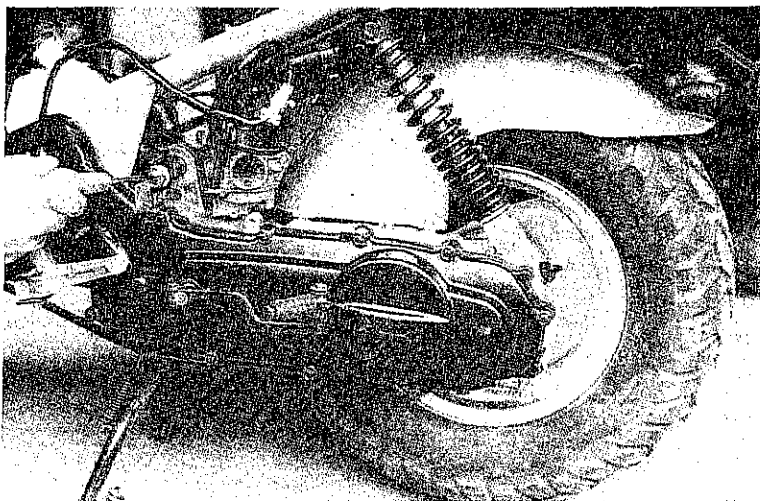

9.Remove nut of rear brake cable

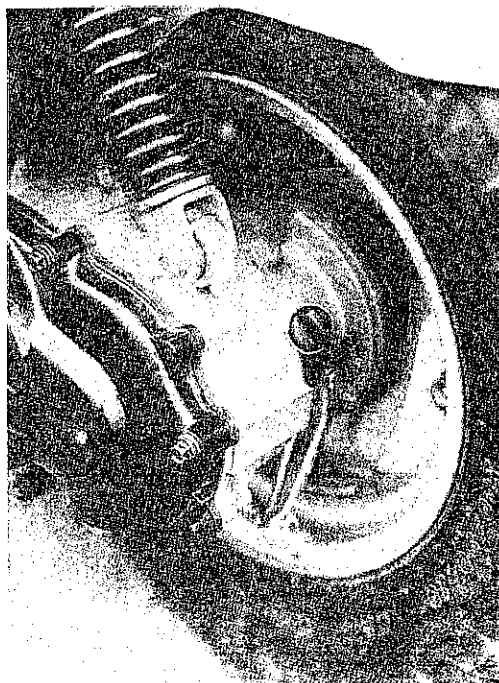

10.Remove the engine

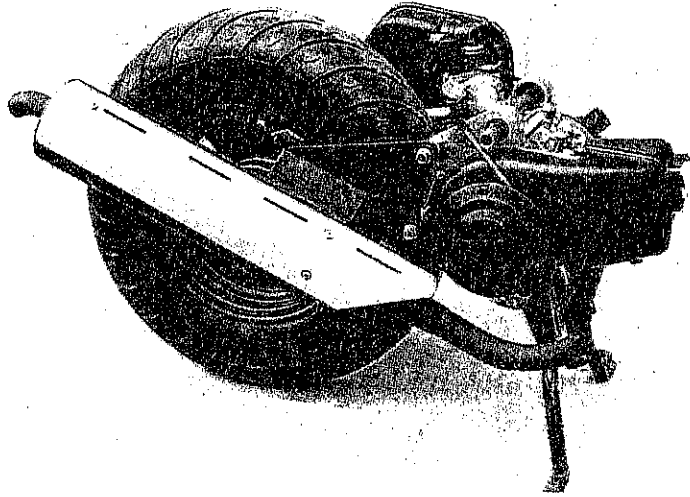

B Installing engine.

1.Install engine follow the opposite above procedure.

2.Locking torque:

M8:2.0~3.0kgf.m

M10:3.0~4.0kgf.m

M12:5.0~6.0kgf.m

After installing,inspect and adjust the following:

1.the wire connecting.

2.throttle cable,oil control cable.

3.let out the air in oil pump.

4.rear brake adjustment.

(4) Drive pulley, starter. clutch. driven pulley

- A. troubleshooting
- B. Measurement data
- C. drive pulley
- D. Starter
- E. Clutch. driven pulley

A. Troubleshooting:

a. Engine starts, but vehicle don't move.

1. driving belt worn out
2. driven plate worn out
3. clutch lining worn out

b. The vehicle stops or tremble when running.

1. clutch hammer spring cracked or broken.

c. Can't reach high speed, no pick-up

1. driving belt worn out.
2. driven-plate spring distortion.
3. hammer roller worn out.
4. driven plate abnormal.

Note:

No grease and oil should be distributed over driving belt and driven plate.

B. Measurement data

Item	standard value	limit of use
the bush inner dia of slide driving plate	20.035~20.085	20.123
driving plate flange outer dia	19.960~19.974	19.911
hammer roller outer dia	15.992~16.008	15.5
clutch cover	107~107.2	107.5
driving plate spring free length	87.9	82.5
driving plate sets outer dia	33.965~33.985	33.940
slide driven plate inner dia	34.000~34.025	34.070



(C)Driving pulley.

1.Remove the 10 screws of left cover.

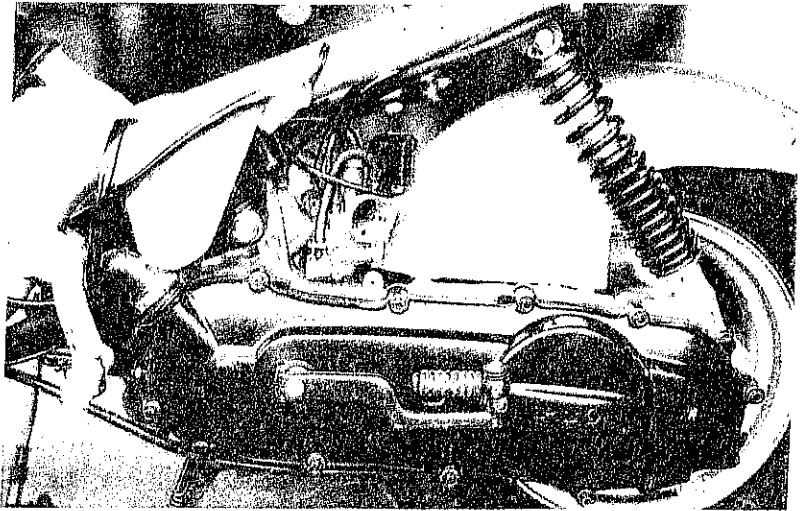

2.Take off the left cover

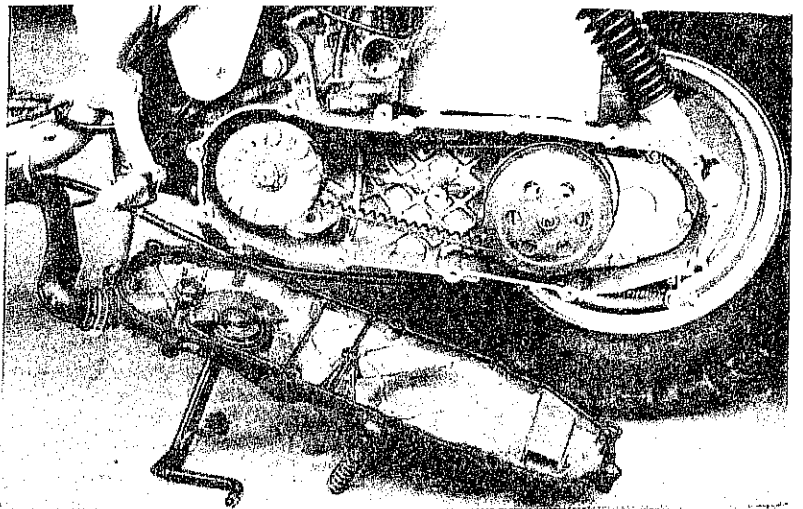

3.Remove the fixing nut of clutch.

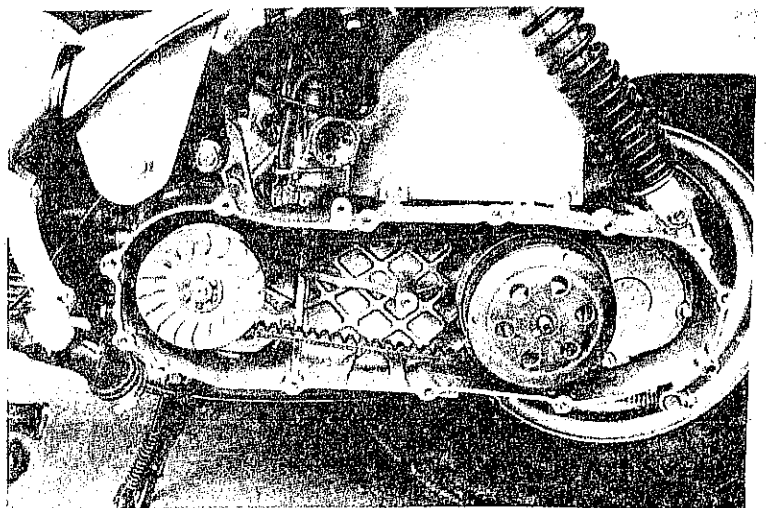

4. Take off the ramp plate.

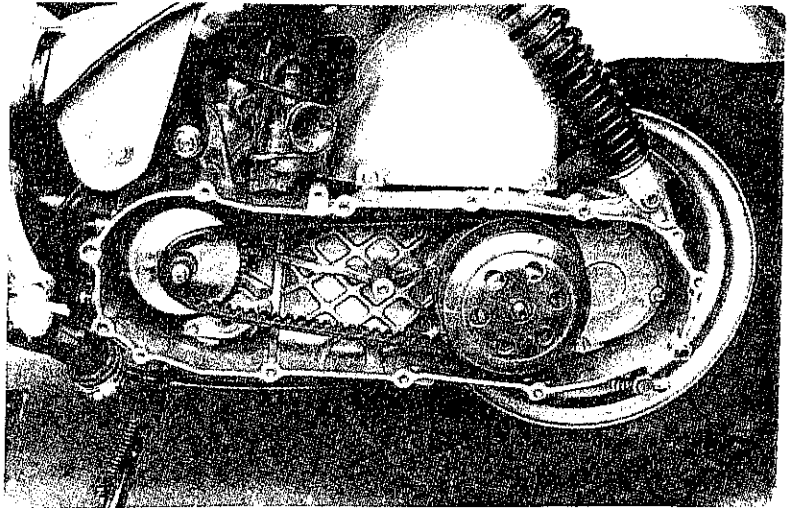

5. Take off the belt & rear clutch.

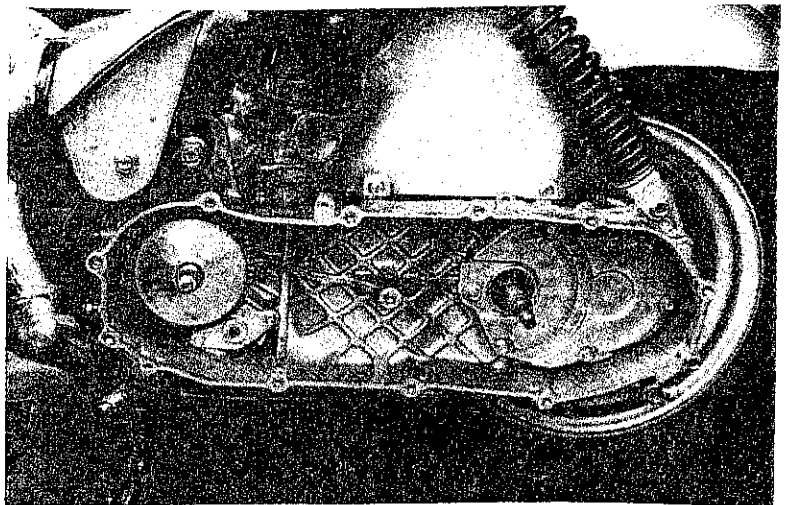

6. Take off the driving plate.

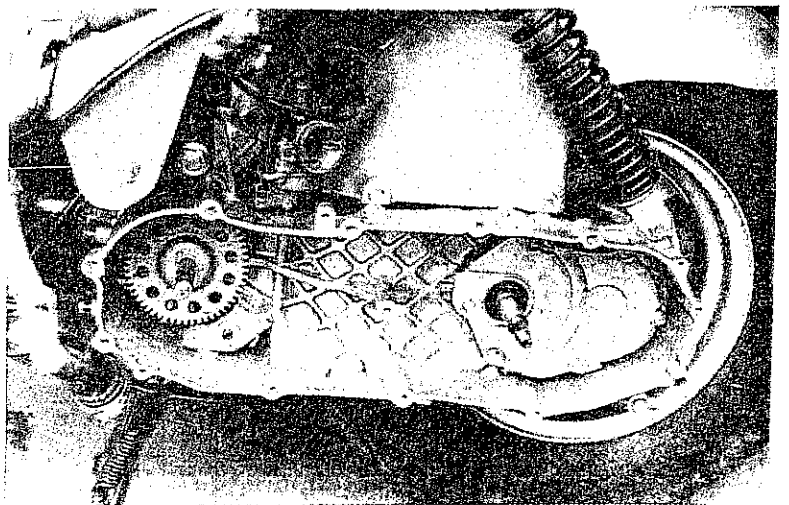

7. Take off the driving gear starter set.

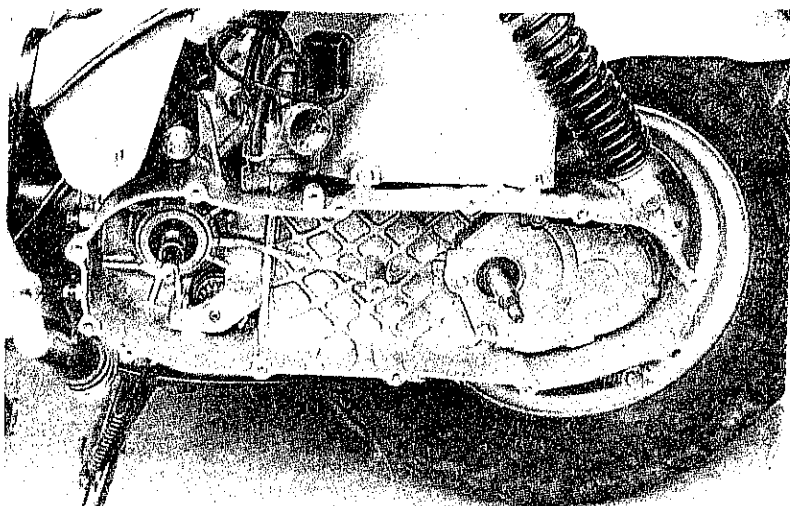

8. Remove the driving gear locking plate.

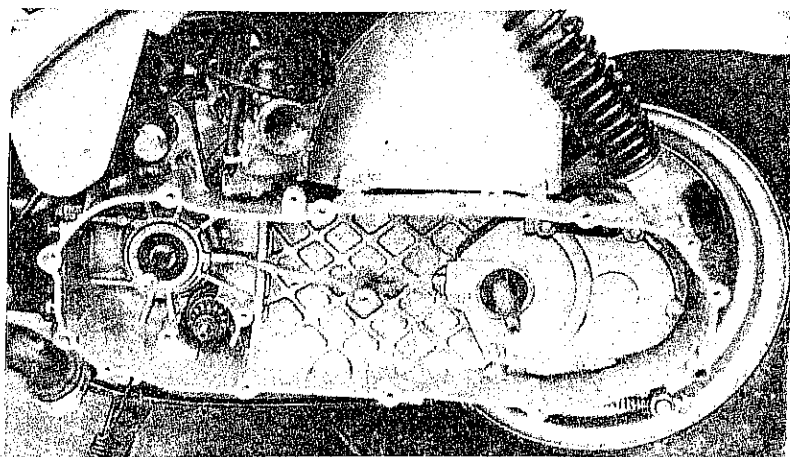

9. Take off the idle gear.

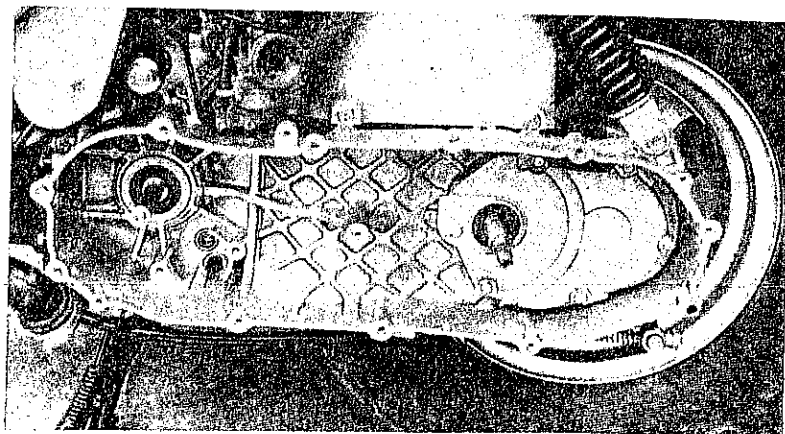

10. Assemble driving pulley follow the opposite procedure of dismantling.

Locking torque:

M10 nut of driving pulley:

3.2~4.0kg.m

M10 nut of clutch outer:

3.5~4.0kg.m

11. Checking driving belt

(1) check driving belt if cracked, rubber and fiber is loosen, also check if is abnormal or worn out.

(2) driving belt width:  
limit of use: change it as it below 16.5mm.

(3) Remove slide driving plate sets.

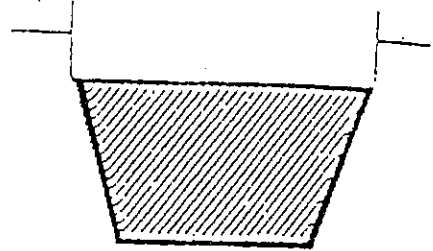

12. Disassemble slide driving plate sets:

(1) Remove bush of slide driving plate.

(2) Remove screw, and disassemble the cover of slide driving plate.

(3) Remove RAMP plate.

(4) Remove hammer roller.

13. Checking.

(1) Check the wearing degree of hammer roller.

limit of use : change it as it is below 15.5mm.

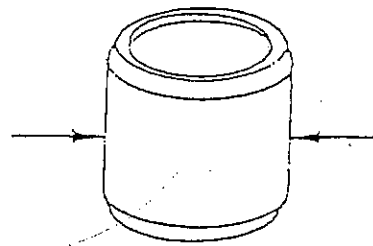



D. Starter dismantle

1. Dismantle left crankcase cover

2. Loose hexagon nut, then remove the starter lever.

3. Loose two screw of space pate

4. Loose stater spring from start returning positioner.

5. Remove driven gear comp. of kick starter.

6. Remove the retaining ring C type.

7. Remove spindle comp. of kick starter.

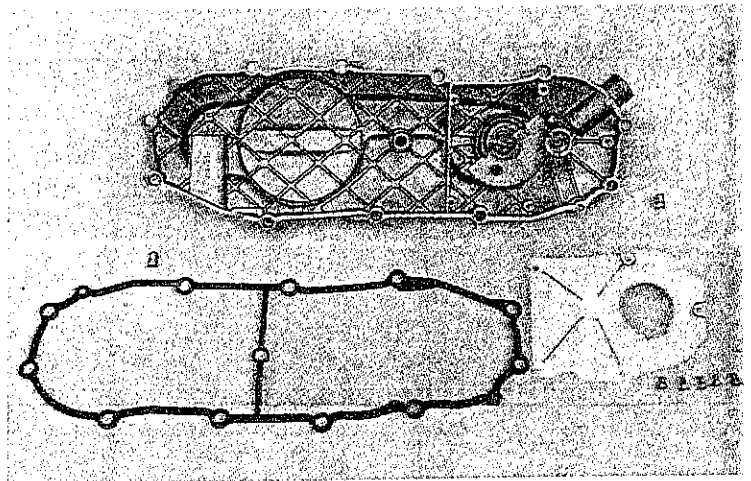

8. Checking starter

- a. Check the wearing degree of outer diameter of spindle comp. inner diameter of bush and gear.
- b. Check the wearing degree of shaft of driven gear comp. gear sets and ratchet.

9. Assembling the starter

Assemble the starter follows the opposite procedure of dismantling.

Note:

- ① One side of the torsion spring must be hooked on the trough of sector gear certainly another side must be hooked on the cylinder inside the left crankcase.
- ② Put some grease in every shaft and gear sets before assembly.

## E. Clutch driven pulley

### 1. Remove the clutch

- a. Remove left crankcase cover.
- b. Remove driving plate.
- c. Remove driving belt.

Remove 10mm nut, then remove clutch.

### 2. Assemble the clutch follows the opposite procedure of dismantling.

locking torque:

M10:3.5~4.0kg.m

### 3. Checking clutch: dismantling tool

- a. Check clutch driving face.  
Check clutch cover wearing condition.  
Inner diameter measurement.  
limit of use: change it as it above 107.5mm.

- b. Check clutch lining wearing condition: lining thickness measurement.  
limit of use: change it as it is below 2.5mm.

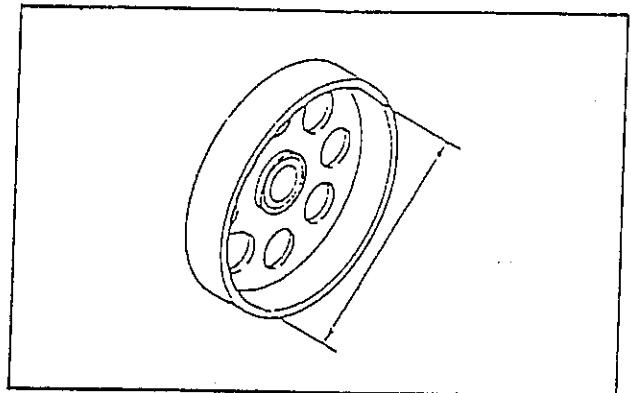
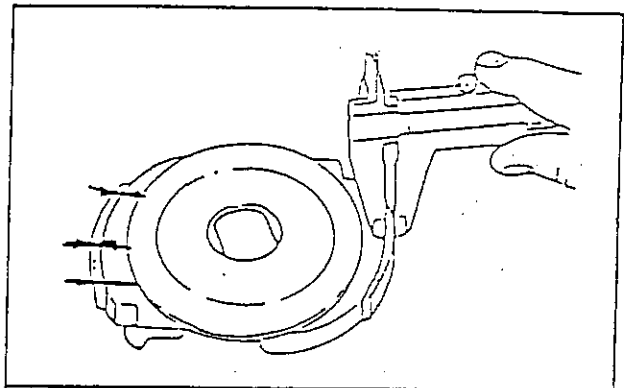

c. Check driving spring free length: standard: 87.9mm  
limit of use: change it as it is below 82.9mm

d. Check wearing condition of driving plate sets.

Outer diameter measurement:  
limit of use: change it as it is above 33.940mm.

e. Check wearing condition of slide driven plate.

Inner diameter measurement:  
limit of use: change it as it is above 34.070mm.

f. Check if there is any wearing occur to the ditch.

g. Check wearing condition of seal location, if necessary change a new one.

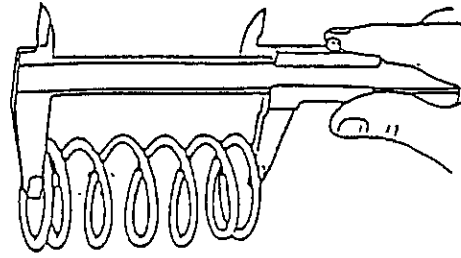



(5) Cylinder head , cylinder , piston :

- A. troubleshooting
- B. the operation notice
- C. the operation data
- D. dismantling cylinder head
- E. checking cylinder head flatness
- F. cleaning out the carbon in combustion chamber
- G. dismantling cylinder
- H. dismantling piston
- I. checking cylinder, piston
- J. installing cylinder, piston

#### A. Troubleshooting.

a. compression pressure is too low, difficult to start engine slow running unsmoothly.

1. Cylinder washer cracked.
2. Spark plug not being locking well.
3. Piston ring worn out or cracked.
4. Cylinder, piston worn out or injured.
5. Reed valve is out of order.

b. compression pressure is too high, engine overheating, knocking: cylinder head, piston tip too much carbon accumulated.

c. piston noise

1. cylinder, piston worn out.
2. piston pin hole, piston pin worn out.
3. connecting rod small end, bearing worn out.

d. piston, cylinder noise

1. piston ring worn out, cracked.
2. cylinder worn out, injured.

#### C. The operation notice:

1. clean before operation to avoid other object drop in engine.
2. the connecting washer must be washed cleanly.
3. dismantle cylinder and cylinder head, don't injure the contact surface.
4. cylinder inner surface and piston outer face can't be injured.
5. the dismantling part should be washed cleanly when checking, the contact surface should lubricate by specified oil.

#### D. The operation data information

Item	Standard value	limit of use
Cylinder head straightness	—————	0.10
Piston outer diameter from the lower end of piston 12mm above the skirt edge.	39.950-39.970	39.895
Clearance between cylinder and piston	0.050-0.060	0.100
Piston pin inner dia	10.002-10.008	10.025
Piston pin outer dia	9.994-10.000	9.970
Clearance between piston pin and pin hole	0.004-0.018	0.030
Piston ring gap. (1st ring/2nd ring)	0.15-0.35	0.70
Connecting rod small end inner dia	13.996-14.007	14.025
Cylinder bore	39.995-40.015	40.050

E. Dimantling cylinder head:

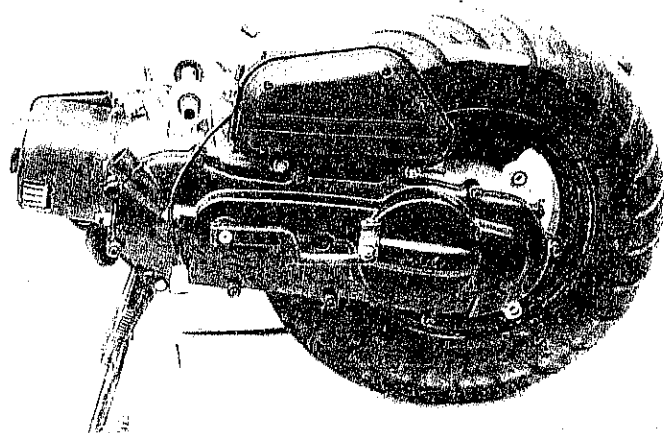

1. Remove the engine

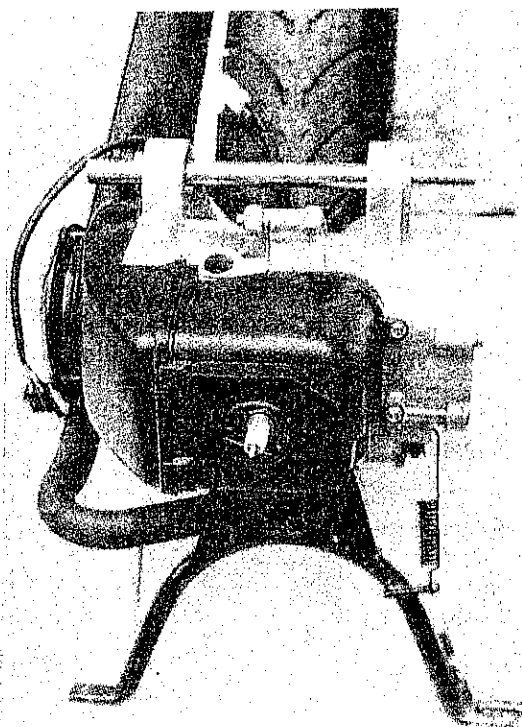

2. Remove the fan cover.

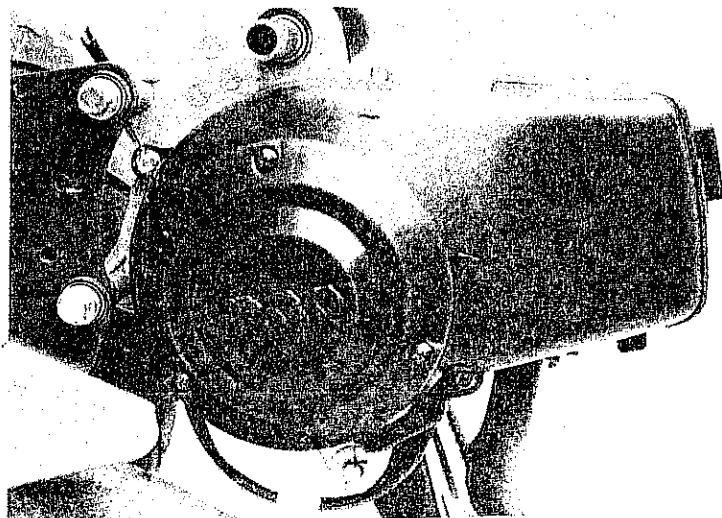

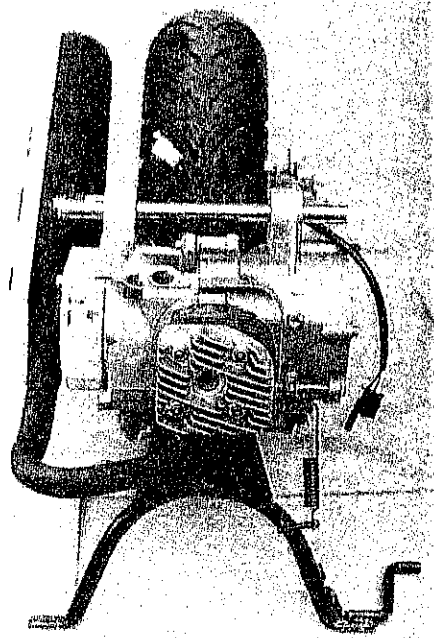
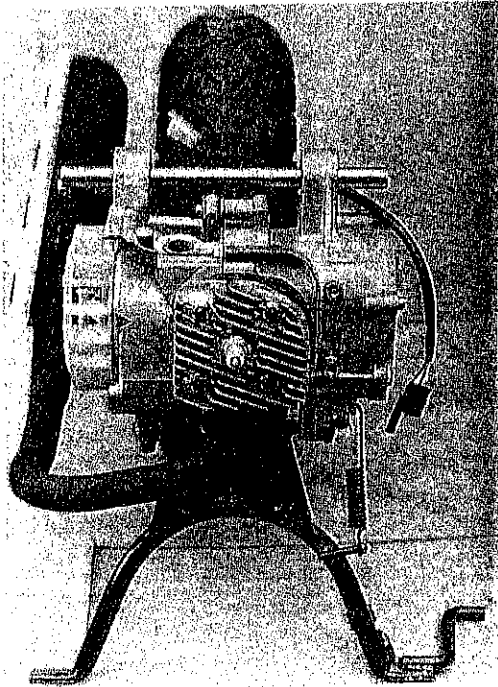

3. Remove the cooling cowl.
4. Remove 4 bolts on the cylinder head, then cylinder.
5. Assemble the cylinder head follow the opposite above procedure.  
looking torque:  
M6:1.0~1.2 kg-m

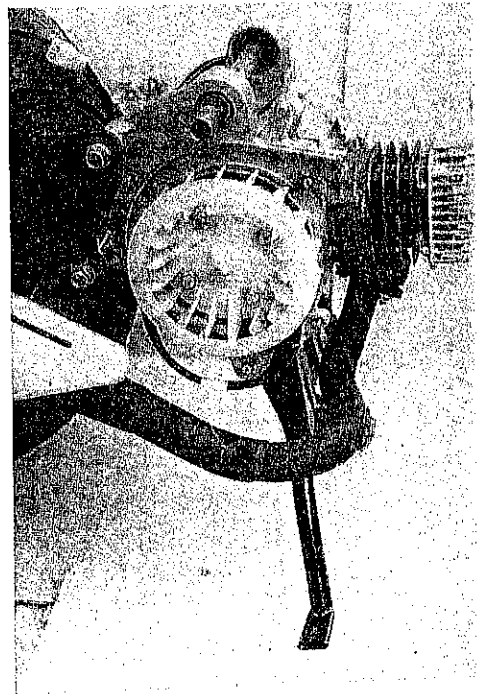

F. Checking flatness of cylinder head.

Check the flatness of every contact surface.

limit of use: If it exceeds 0.01mm change a new one.

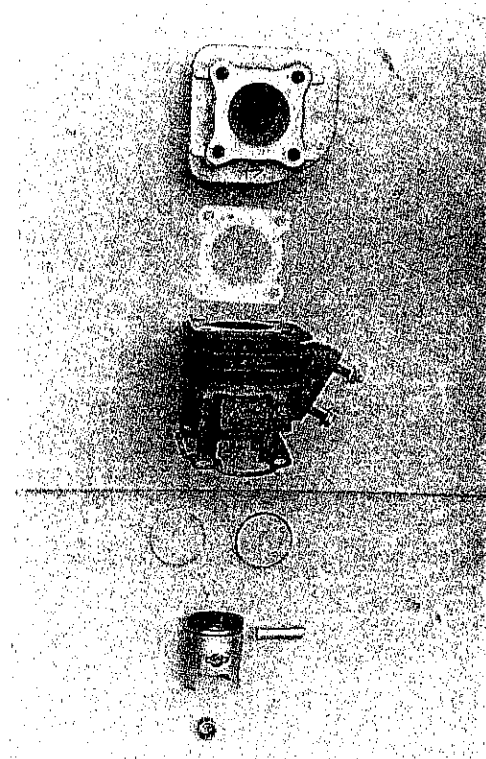

G. Cleaning out the carbon in combustion chamber.

Clean out the carbon collected in combustion chamber.

Do not injure the combustion chamber and contact surface of cylinder during cleaning operation.

## H. Dismantling cylinder

1. Loose two nuts of muffler, then remove the muffler after remove the cylinder head.

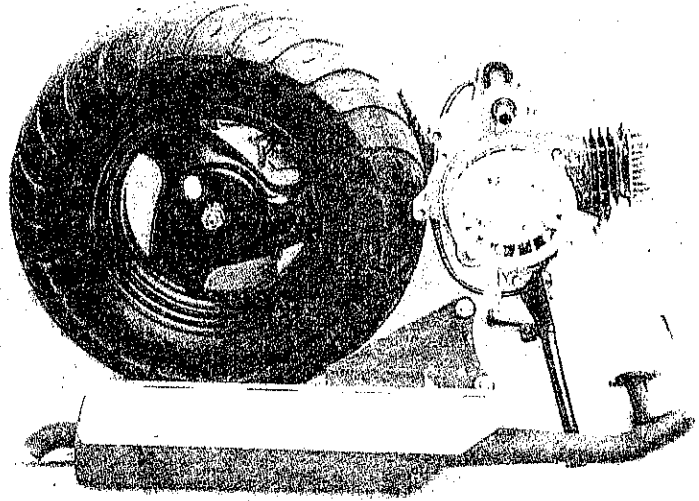

2. Remove the cylinder.

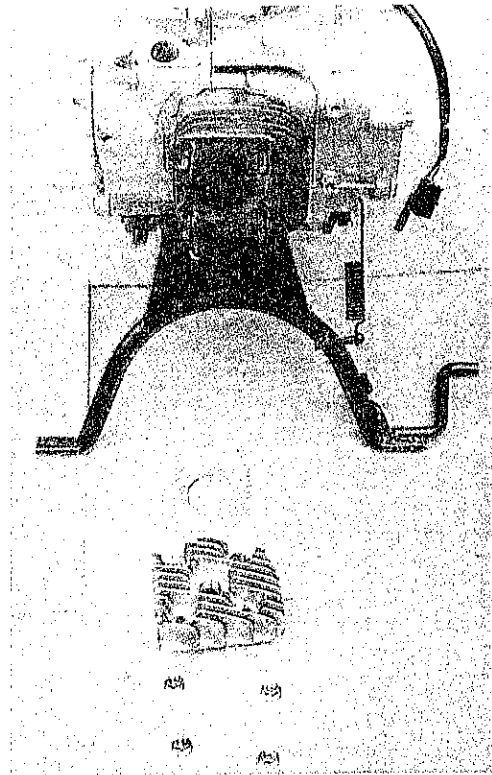
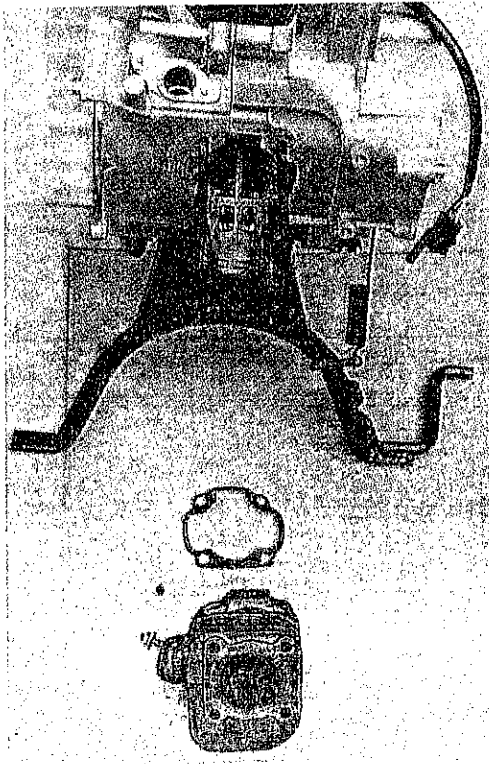

1. Dismantling piston:

1. Remove piston pin clip,  
then remove piston pin  
and take off the piston.

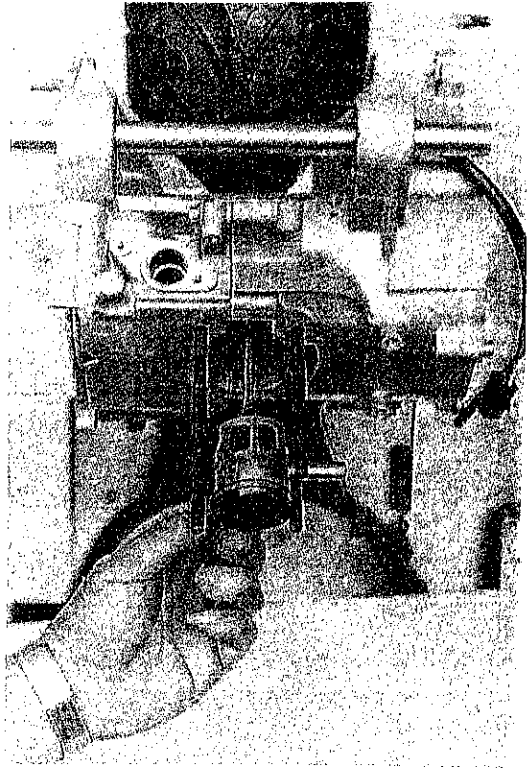

2. Open the piston ring,  
remove piston ring from  
the opposite direction  
gap.

3. Remove the 1st ring, then  
2nd ring.

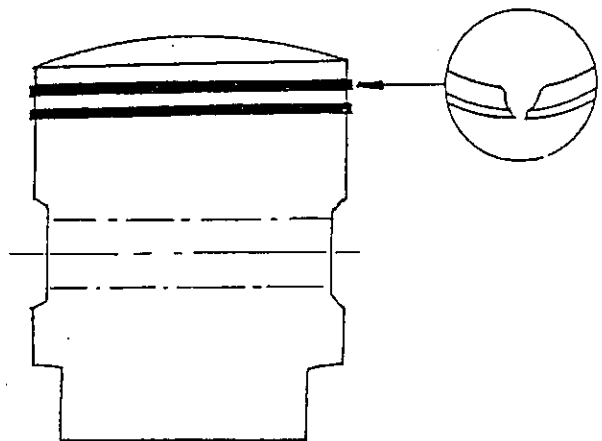

### J. Checking cylinder, piston:

1. Check the worn and injure of contact surface of cylinder and piston.
2. Clean out the carbon in cylinder exhausting port.

Be careful not to injure inner surface of cylinder.

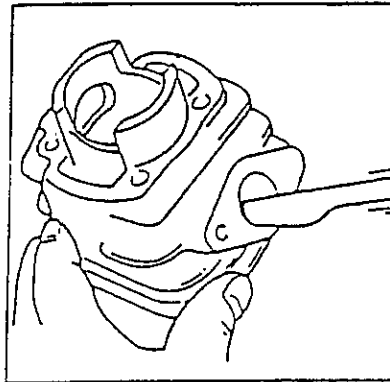

### 3. Cylinder bore measurement:

- (1) Measure each point (A)(B)(C) orderly, and in X.Y. direction to find the smallest value.
- (2) Limit of use : change it as above value exceeds 40.050mm.

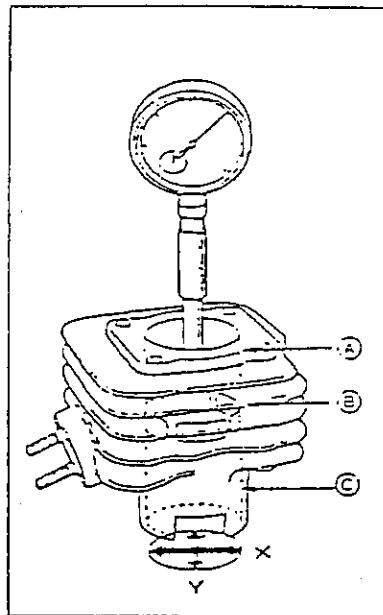

### 4. Piston outer diameter measurement:

- (1) Measure from the lower end of piston, 12mm above the skirt edge.
- (2) Limit of use: change it as above vlaue is less than 39.885mm
- (3) Calculate the clearance between cylinder and piston.  
limit of use: change it as it exceeds 0.100mm

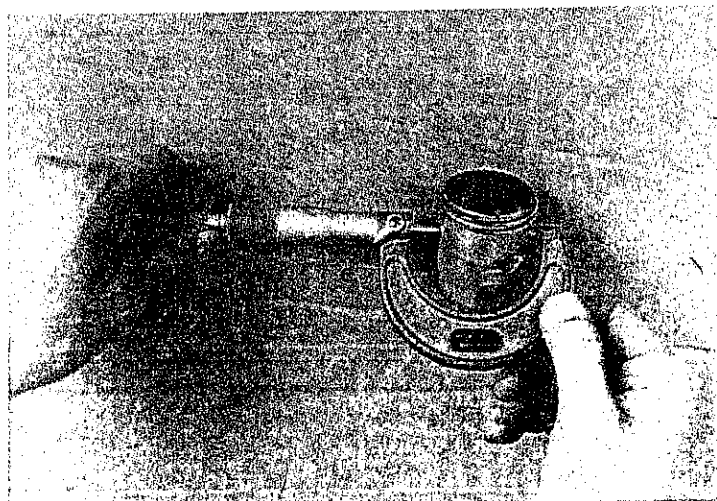



5. Piston pin hole inner diameter measurement:  
 limit of use: change it as it is more than 10.029mm

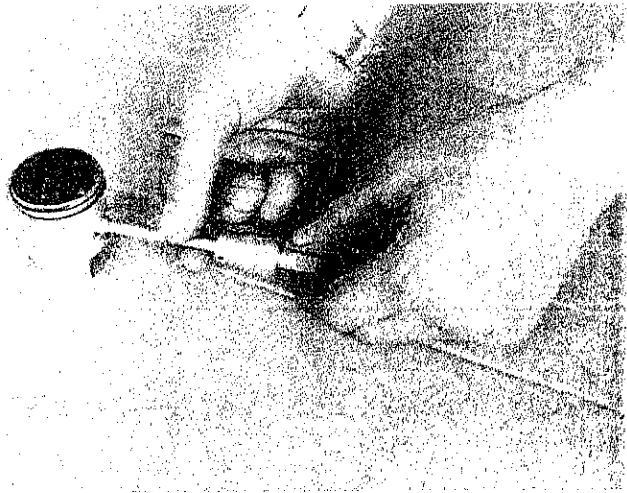

6. Piston pin outer diameter measurement:  
 limit of use: change it as it is less than 9.970mm

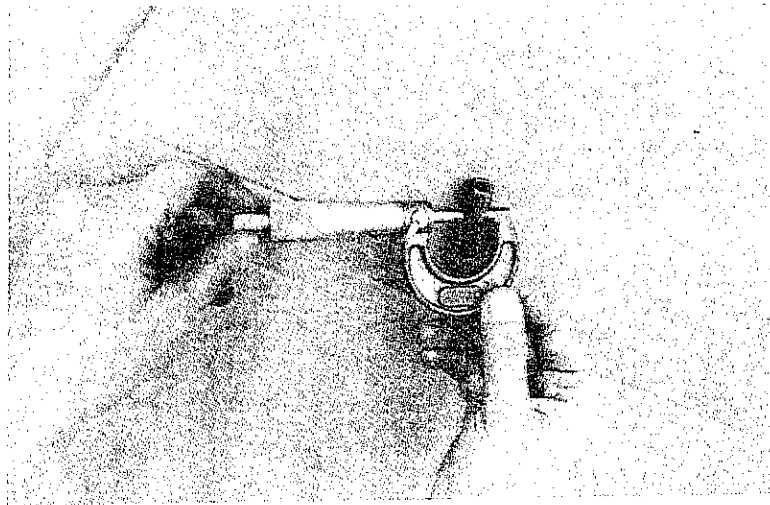

7. Checking piston ring:  
 measure piston ring gap:  
 limit of use : change new one  
 when the first ring and second  
 ring are over 0.4mm.

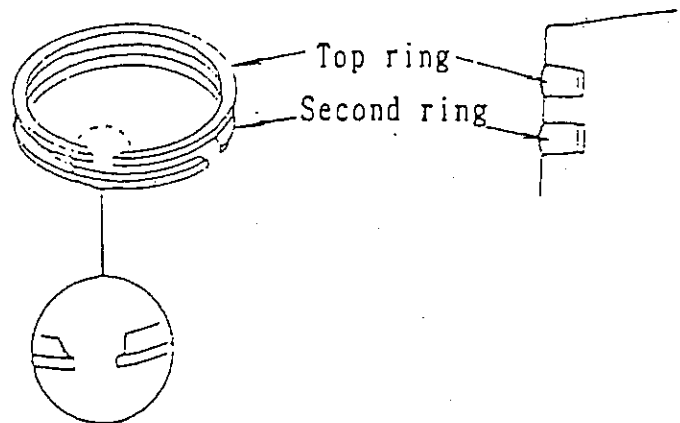

With piston and cylinder wall horizontal direction, press the piston ring into cylinder, then measure the gap.

### 8. Checking connecting rod small end

(1) place piston pin, bearing into connecting rod small end to check the slackness of piston pin.

(2) measure connecting rod small end inner dia. limit of use: change a new one as it is over 14.025mm.

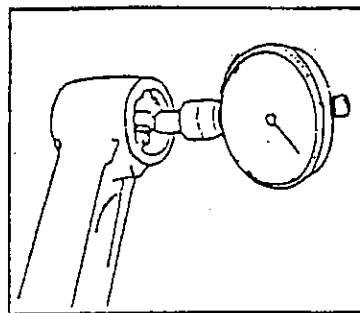

K. Installing piston, cylinder:

1. Place the piston ring into second ring ditch, then install the piston ring into first ditch.
2. Piston ring should be evenly forced into piston ring ditch. After the assembling, confirm that piston ring sliding surface is at the same height as piston outer surface. If piston ring can't put into ditch, please clean out the carbon in piston ring ditch or in piston ring.
3. a. piston ring must be installed to correct position.  
b. after installing the piston ring, it should be rotated freely.  
c. when it is necessary to change new piston ring, change the whole set.
4. The clearance of the piston ring gap between the lock pin in ring ditch should be even.  
a. piston tip → mark, must face to exhausting side.  
b. lubricate the piston pin, then install it.
5. Install cylinder, cylinder head as the opposite procedure of dismantling.

(6) A.C. Alternator flywheel magneto :

A.dismantling AC alternator flywheel magneto.

B.installing AC alternator flywheel magneto.

A:Dismantling AC alternator flywheel magneto.

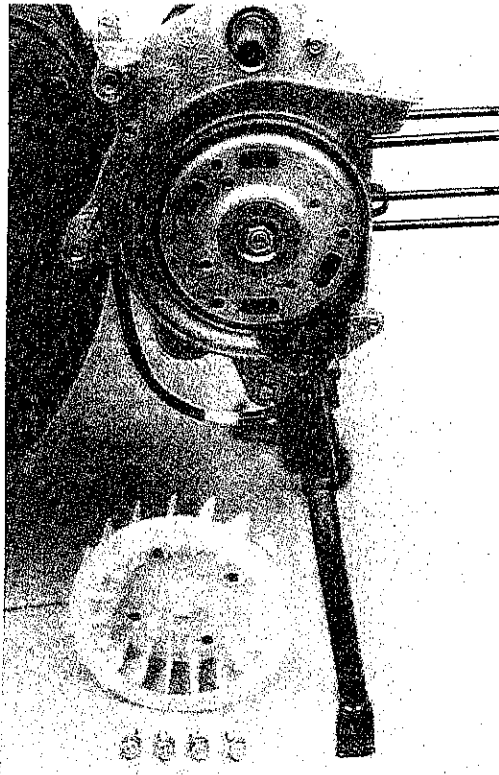

1.Remove fan cowl.

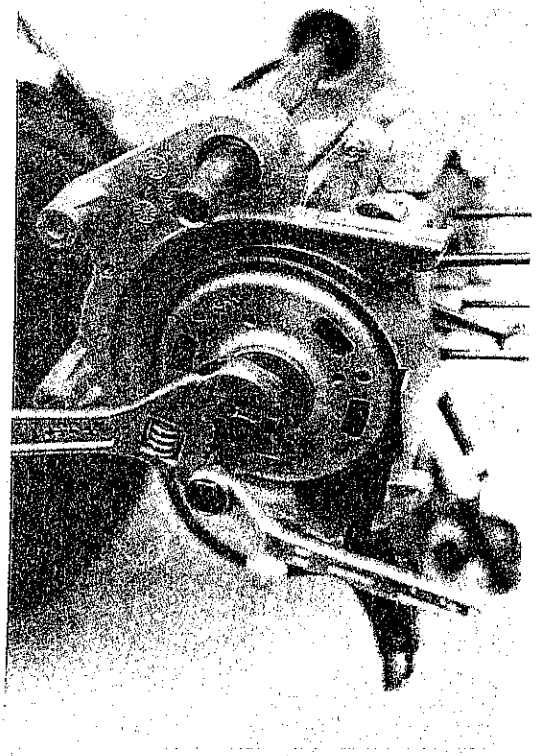
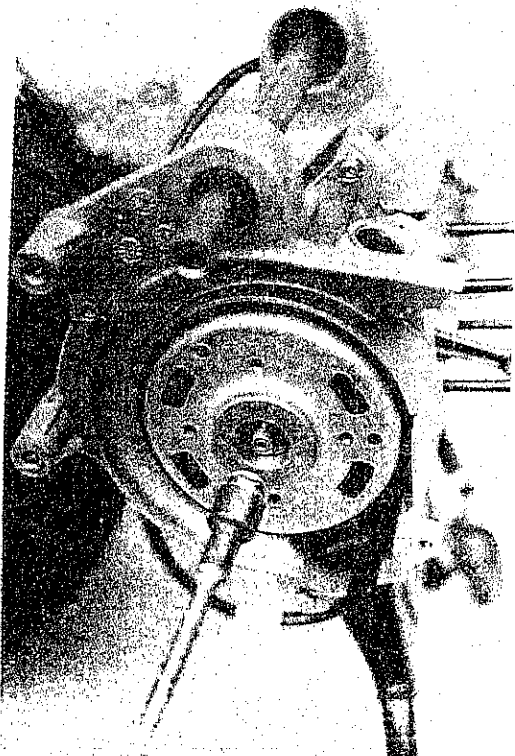

2.Remove fan.

3. Remove the AC  
flywheel magneto  
by special tool.

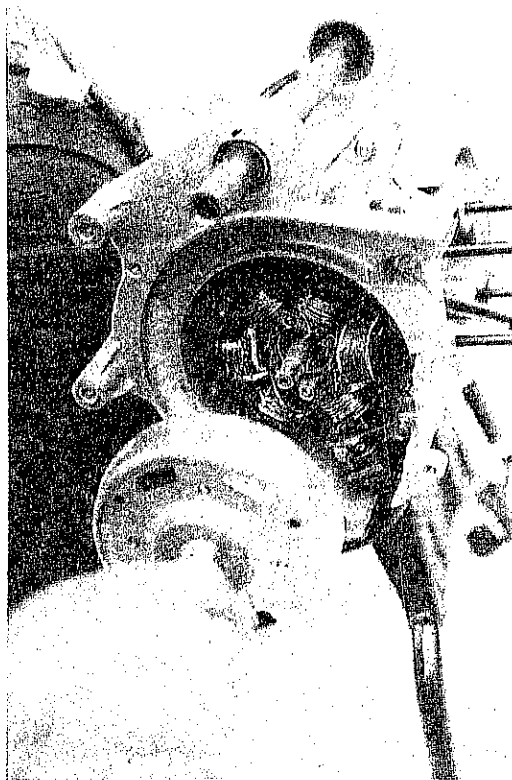

4. Remove the electric plug of AC flywheel magneto.

5. Remove stator screw, and take off stator.

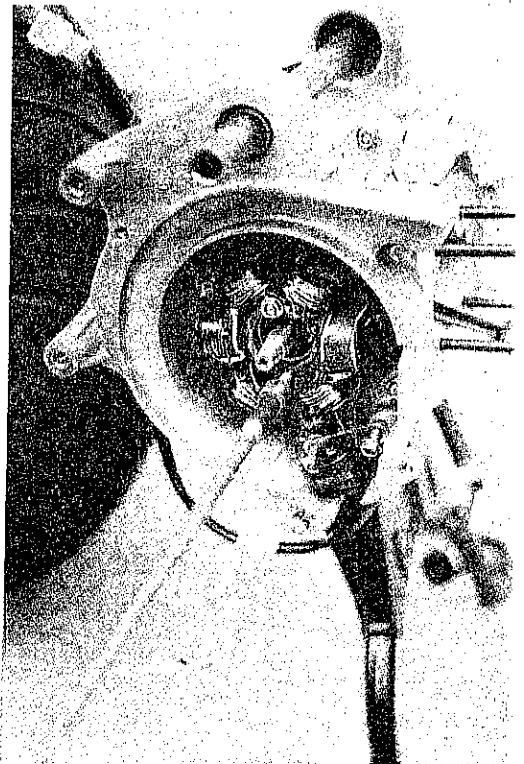

6. Installing the AC flywheel magneto follows the procedure opposite the dismantling procedure.

Locking torque:

M6:1.0~1.2kg.m

M10:3.2~4.0kg.m

## (7)Final transmission mechanism

- A. troubleshooting.
- B. disassemble the final transmission mechanism.
- C. check the final transmission mechanism.
- D. assemble the final transmission mechanism.

### A.Troubleshooting

- Engine can be started, but the vehicle don't move.
  - 1.gear worn out, cracked.
  - 2.gear burnt out.
- noise occur when urnning.
  - 1.gear worn out, burned out, gear surface injured.
  - 2.wearing or looseness of bearing.
- Oil leakage
  - 1.Too much oil.
  - 2.seal worn out or injured.



B. Disassemble the final transmission mechanism:

1. Remove the left crankcase.
2. Remove driving plate.

3. Drain the oil in gear box.

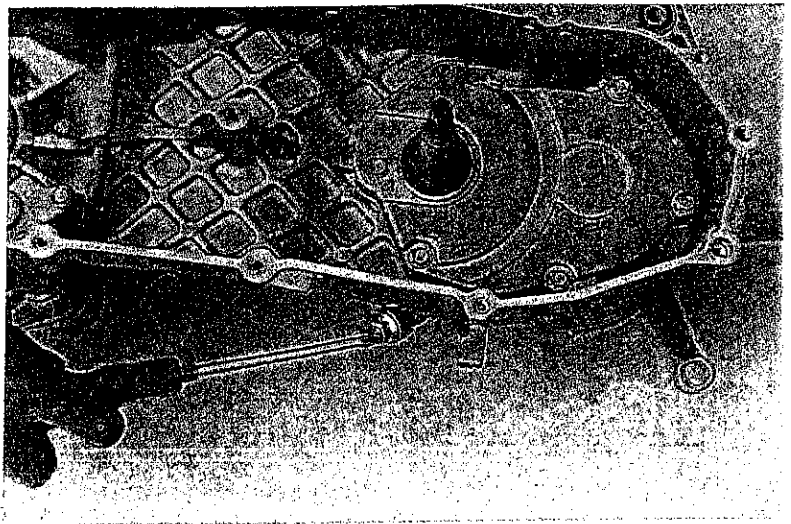

4. Remove the bolt in gear box cover take off the gear box.

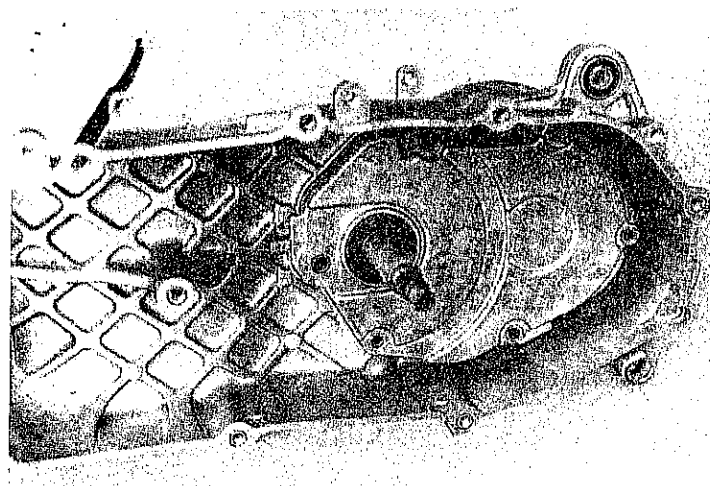
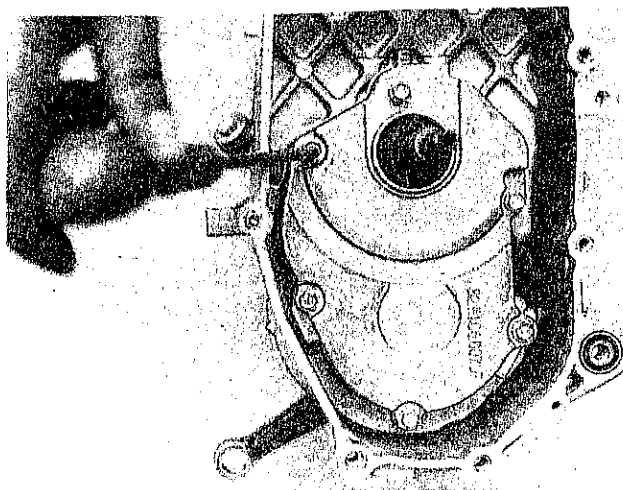

5. Remove final reduction gear and idle gear shaft.  
6. Remove driving shaft from gear box.

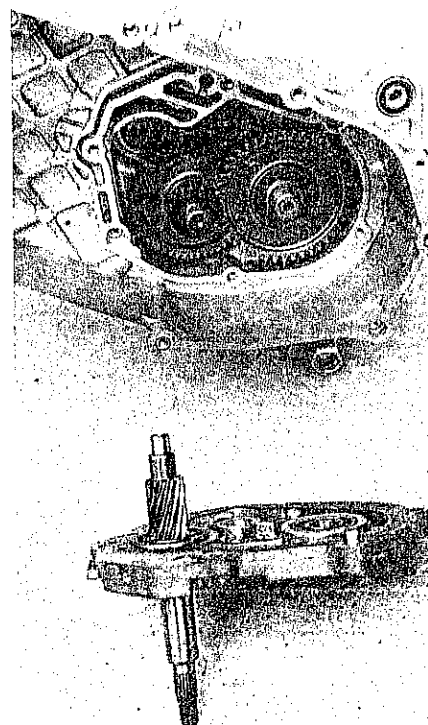

C. Check the final transmission mechanism:

1. Check wearing condition of driving shaft and gears.

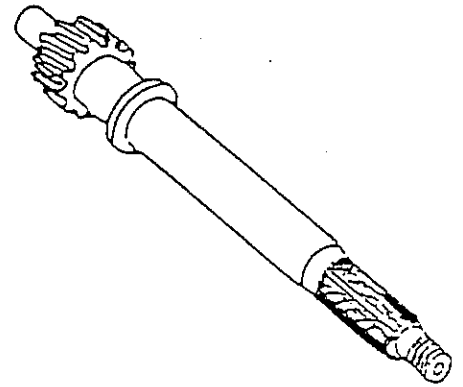

2. Check wearing condition of idle gear shaft and idle gears.

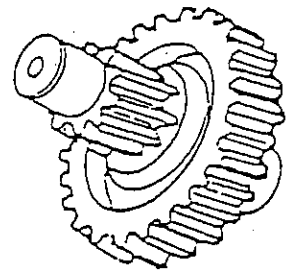

3. Check wearing condition of final reduction gear.

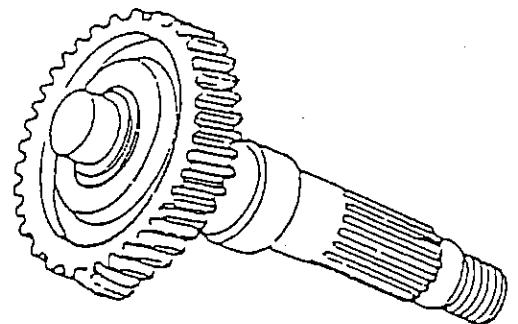

4. Check wearing condition of oil seal and shaft.

D. Assemble the final transmission mechanism, please refer the opposite procedure of disassembling.

Inject 110cc oil (SAE 90) after locking drain bolt.

locking torque: M6 1.0~1.2kg.m

M10 3.5~4.0kg.m

drain bolt M8: 1.8kg.m

## (8)Crankcase , Crankshaft :

- A.disassembling diagram.
- B.troubleshooting.
- C.data
- D.remove crankcase and crankshaft.
- E.check crankshaft.
- F.assemble crankcase.

A. Disassembling diagram

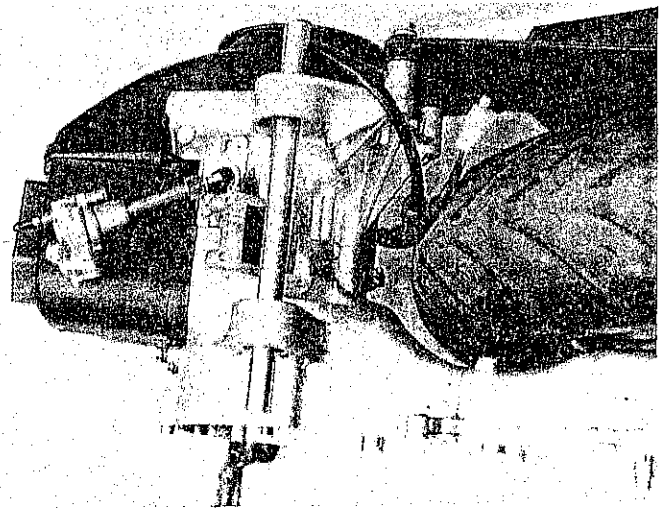
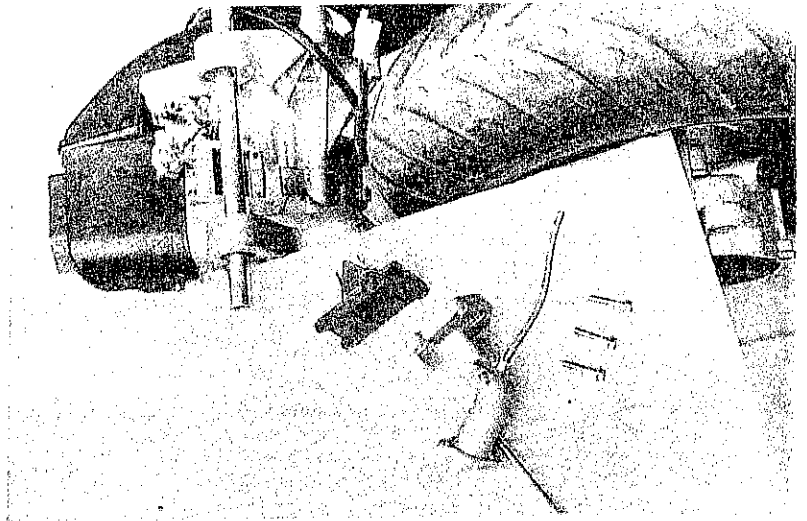
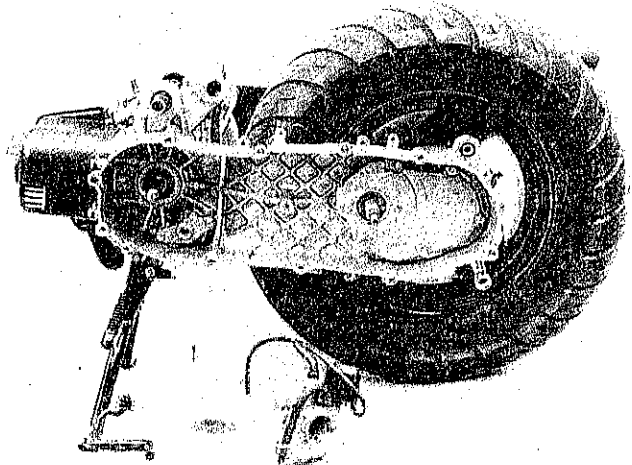

B. Troubleshooting.

Engine noise:

- 1.The bearing of final transmission mechanism is slack.
- 2.Crank pin bearing is slack.
- 3.The bearing of gear box is slack.

Item	standard value	limit of use.(mm)
Clearance of connecting rod big end axle-direction	0.20-0.50	0.71
Clearance of connecting rod big end radial direction.		0.04
Swingness of the crank shaft journal.	0.03	0.10

D. Remove crankcase and crankshaft.  
remove according to the following procedure:

1. remove engine

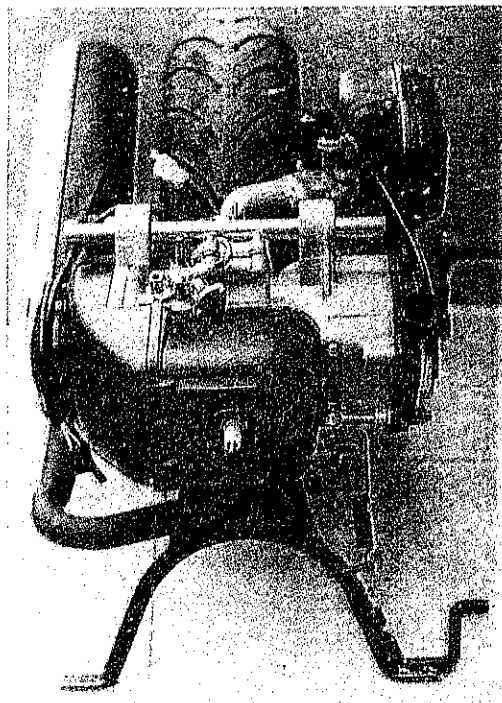

2. remove left E/G case and air cleaner.

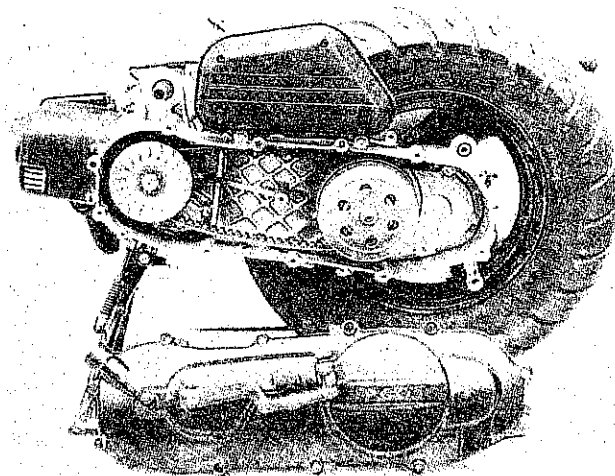

3. remove driving pulley (driving plate). clutch and belt.

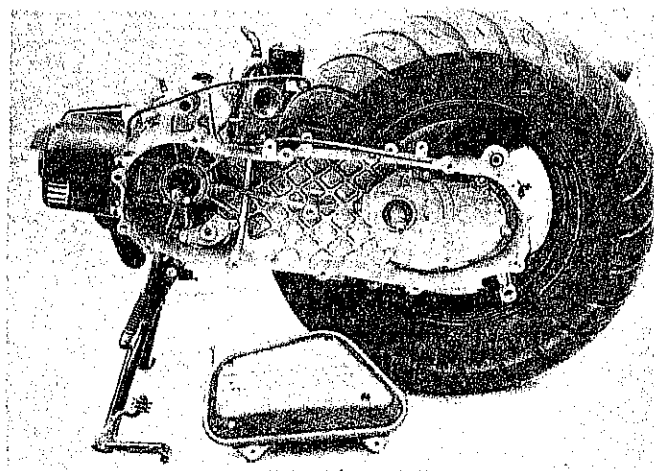



4.remove Carburetor.

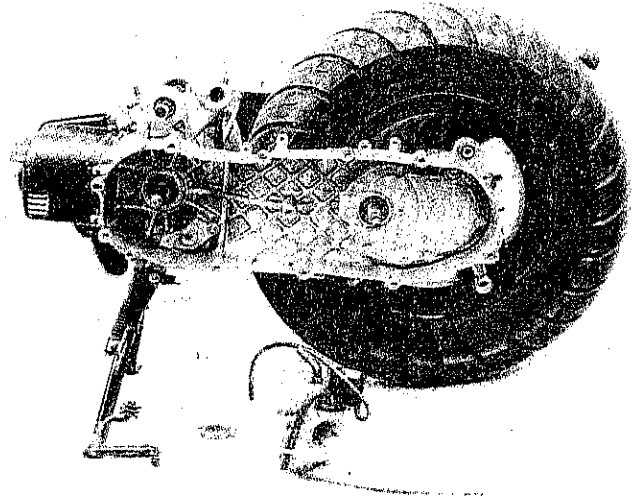

5.remove INtake and Reed Valve

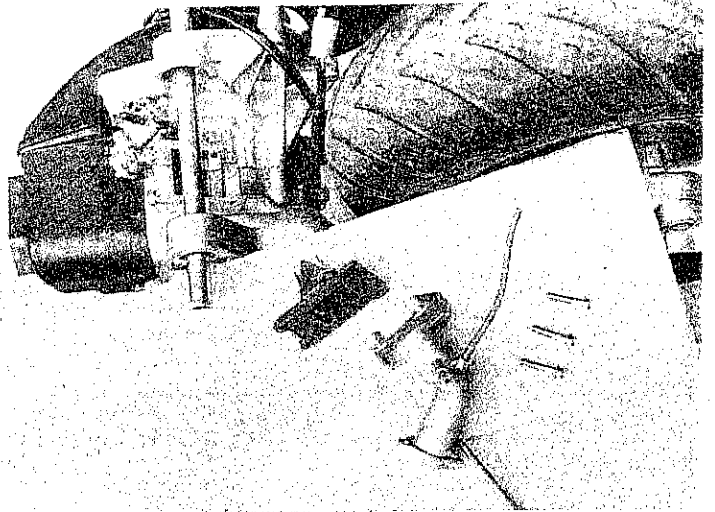

6.remove spark plug. fan cove  
fan cowl and fan.

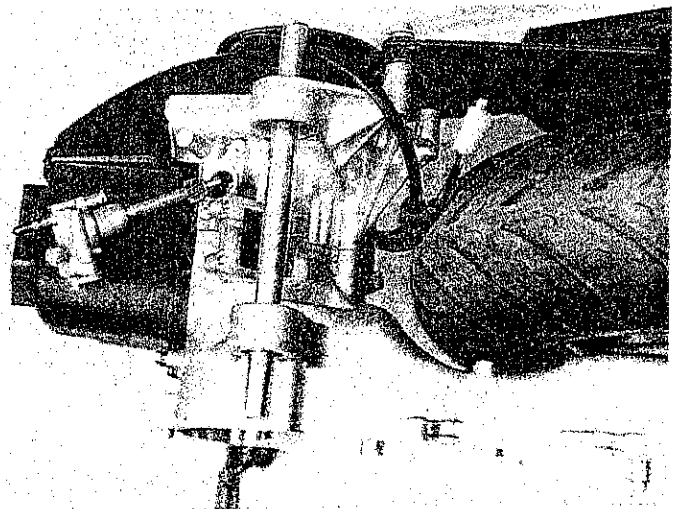

7.remove A.C. flywheel magneto.

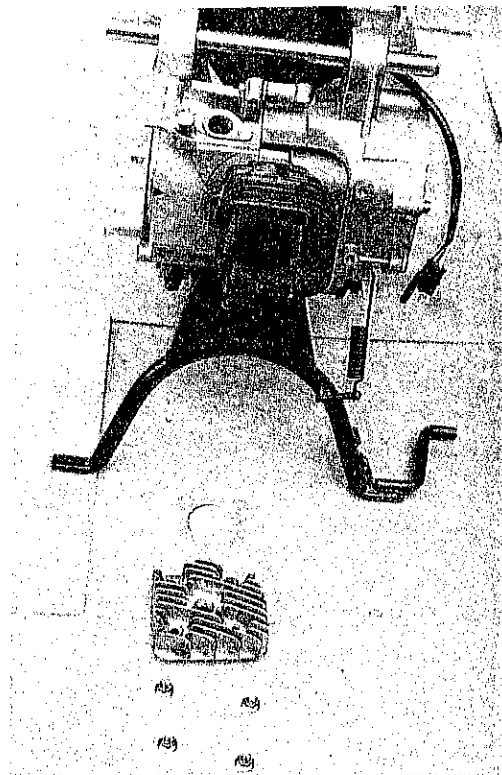

8.remove the oil pump  
and shaft of oil pump.

9.remove the cylinder head  
cylinder and piston.

10.remove the left and right crankcase.

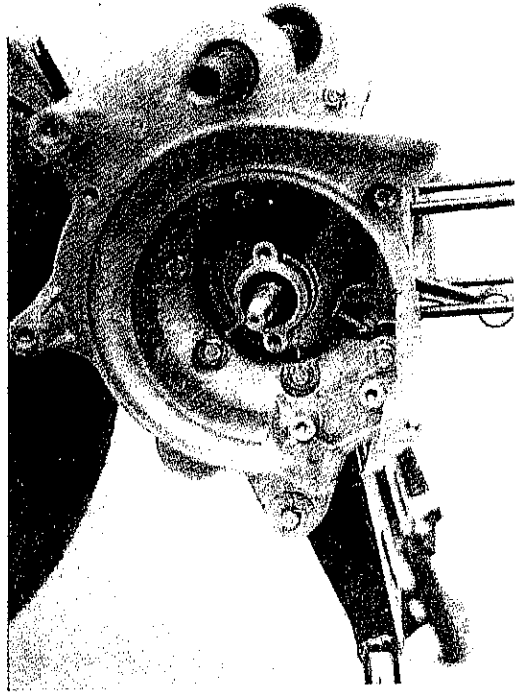

11.remove the central stand, L/R crankcase and take out the crankshaft

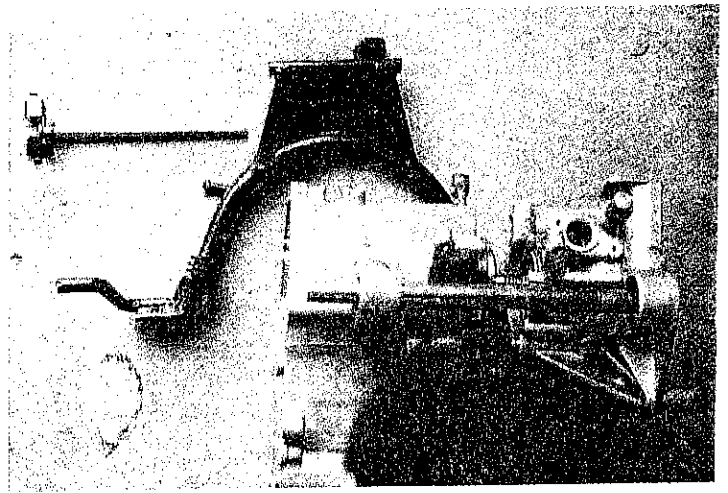

E. Check crankshaft:

1.measure the clearance between crank webs and con-rod big end.

limit of use : 0.71mm

change it as above 0.71mm

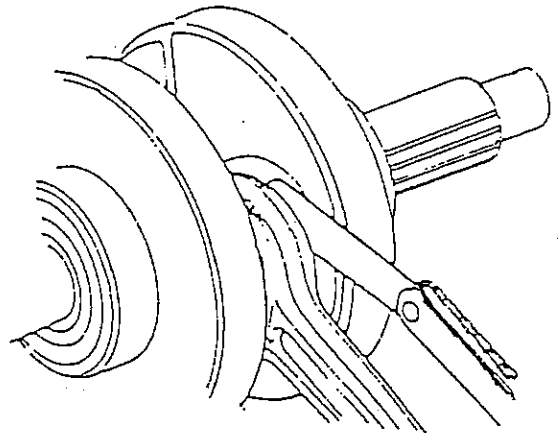

2. check the slackness of connecting rod big end in perpendicular X.Y. directions.  
 limit of use : 0.04mm  
 change it as above 0.04mm

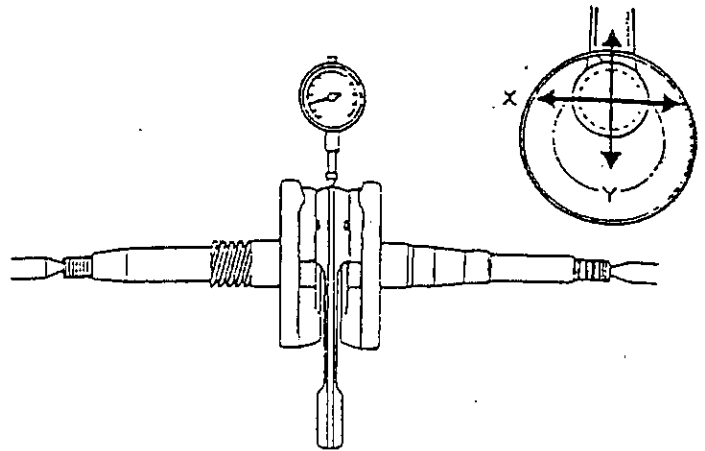

3. measure the swingness of crank shaft journal

limit of use	
A	B
change it as it is above 0.1mm	change it as it is above 0.1mm

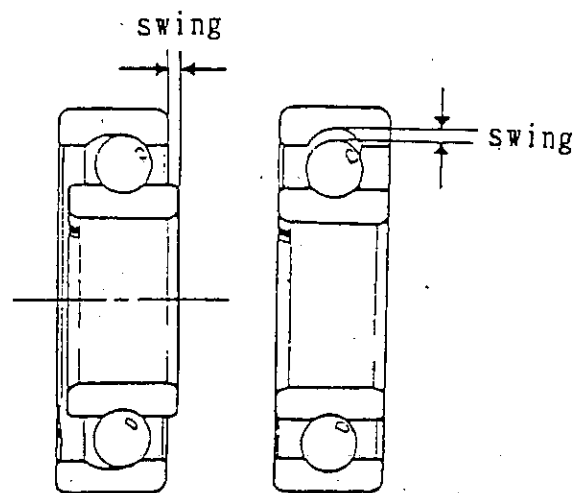
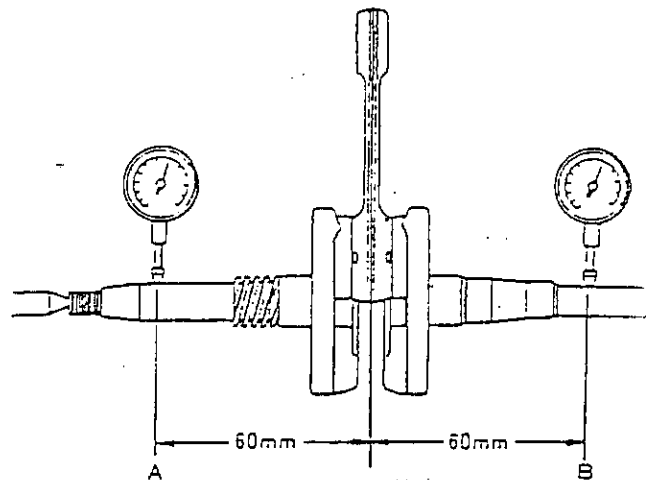

4. check the slackness of crankshaft bearing, if it is slack, change a new one.

horizontal direction      vertical direction

F. Assemble crankcase:

1. assemble crankcase according to the opposite procedure of disassembling.
2. The locking torque of bolts and nuts are described in previous chapter please refer.

## (9) Carburetor:

- A. fuel system diagram.
- B. carburetor disassembling diagram
- C. troubleshooting.
- D. dismantling carburetor.
- E. disassembling float, nozzle.
- F. reed valve
- G. checking fuel cock.

A. Fuel system diagram.

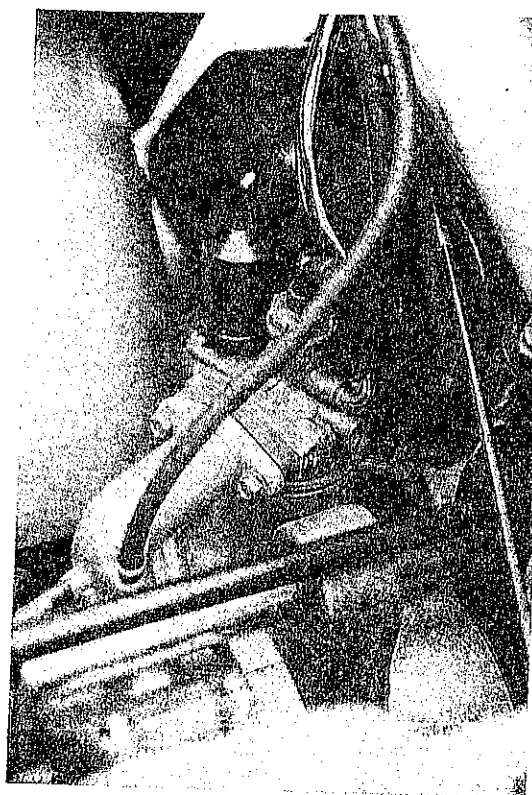
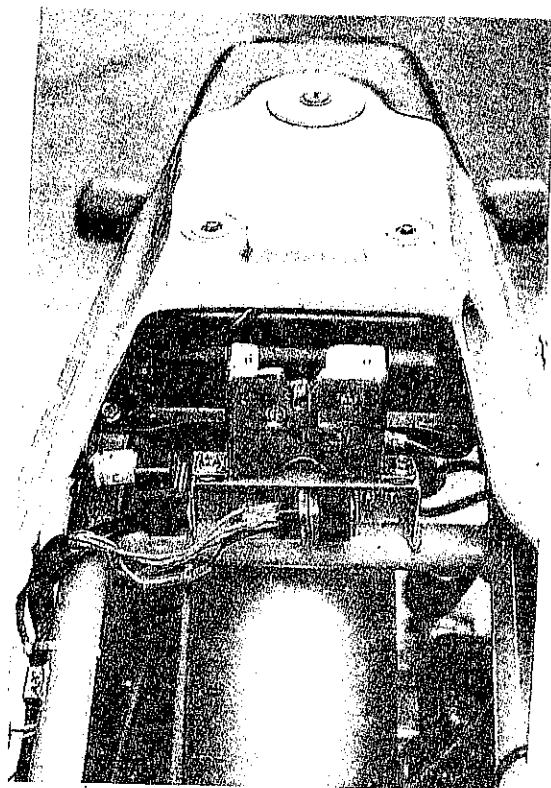

B. Carburetor disassembling

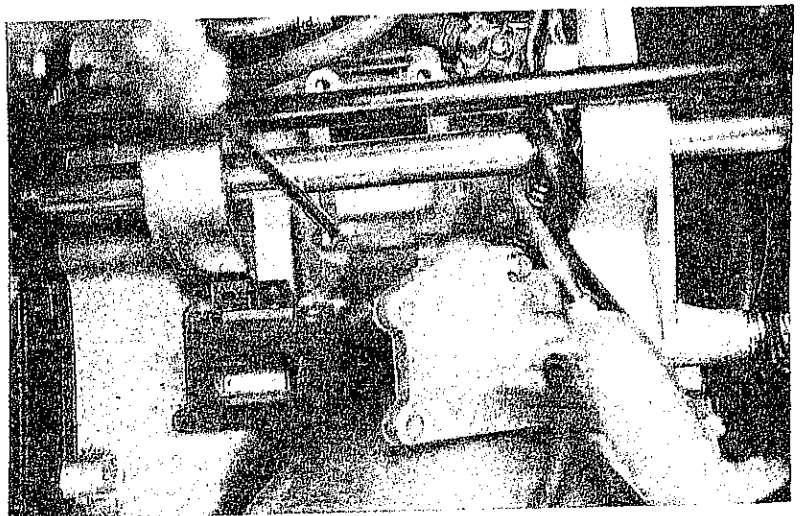
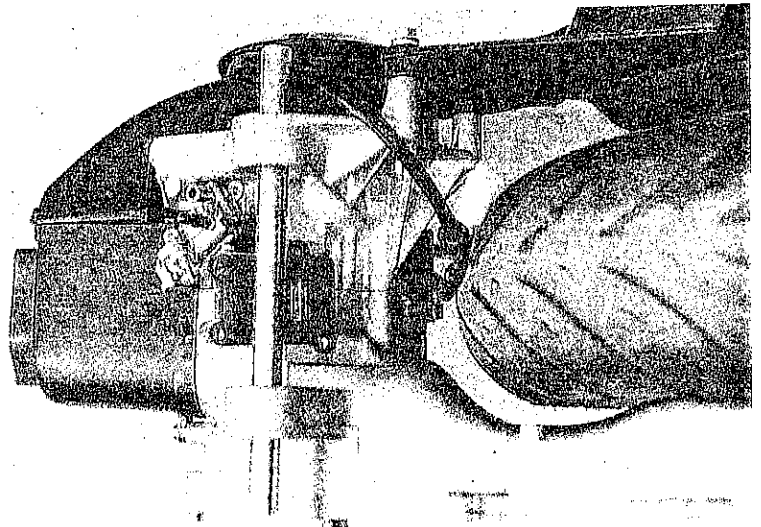
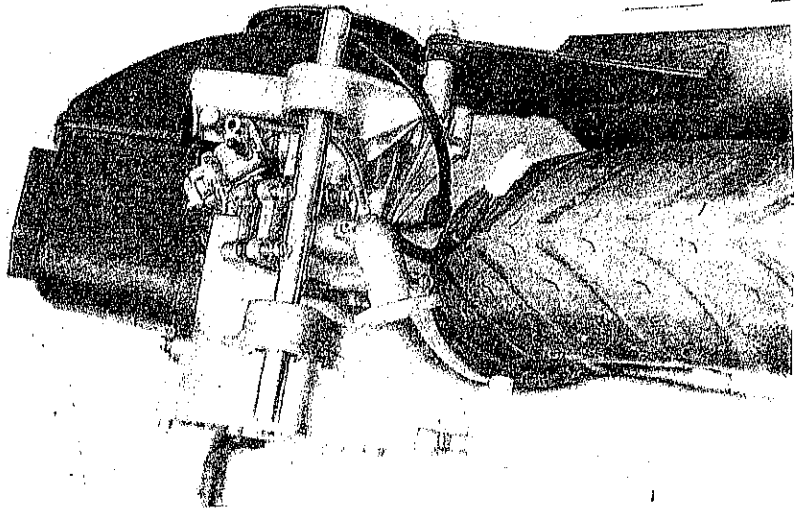



C. Troubleshooting :

a. Engine can't be started:

- 1.no fuel in fuel tank.
- 2.fuel pipe is blocked.
- 3.too much fuel in cylinder.
- 4.air cleaner is blocked.

b. Engine idling RPM unsteady, running unsmoothly.

- 1.carburetor idle adjusted unproperly.
- 2.ignition disorder.
- 3.compression pressure is too low.
- 4.mixture is too thick.
- 5.mixture is too lean.
- 6.air cleaner is blocked.
- 7.air injection is out order.
- 8.fuel is dirty.

c. mixture is too thick

- 1.main jet is blocked.
- 2.fuel tank cover ventilation hole is blocked.
- 3.fuel filter is blocked.
- 4.fuel pipe curved, squeezed or blocked.
- 5.float valve is abnormal.
- 6.oil level is too low.
- 7.air pipe is blocked.

d. mixture is too lean

- 1.float valve is abnormal.
- 2.oil level is too high.
- 3.air jet is blocked.

D. Dismantling carburetor:

1. remove the rear protector luggage box

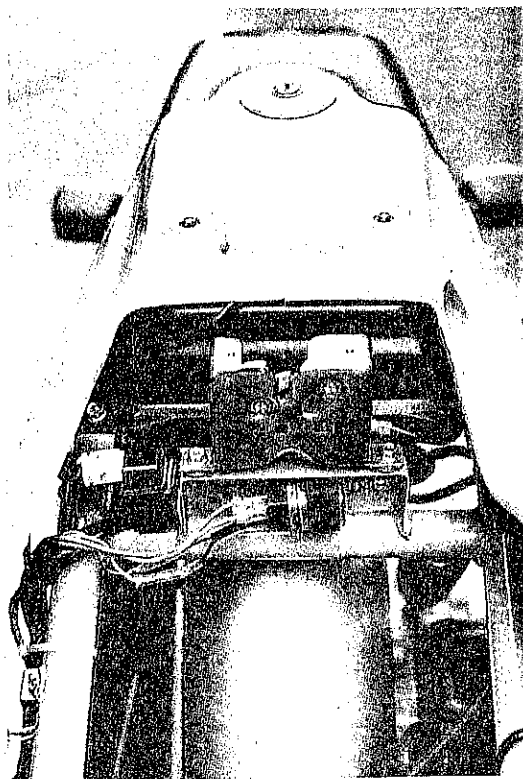

2. loose the hose clamp between carburetor and air cleaner, then remove air cleaner.

3. unscrew carburetor fuel draining screw, drain the fuel (inside the carburetor) off.

4. remove fuel pipe and vacuum pipe which is on carburetor.

5. remove oil pipe on carburetor.

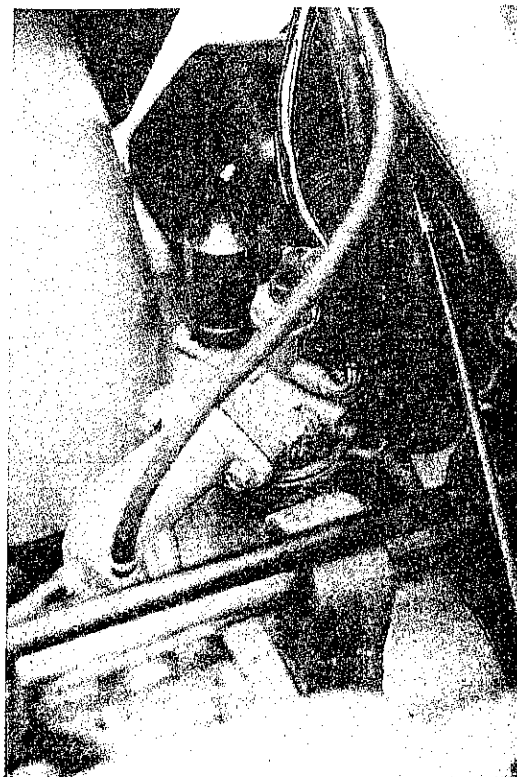

F. Reed valve.

1. dismantling reed valve.

(a) remove air cleaner.

(b) remove carburetor.

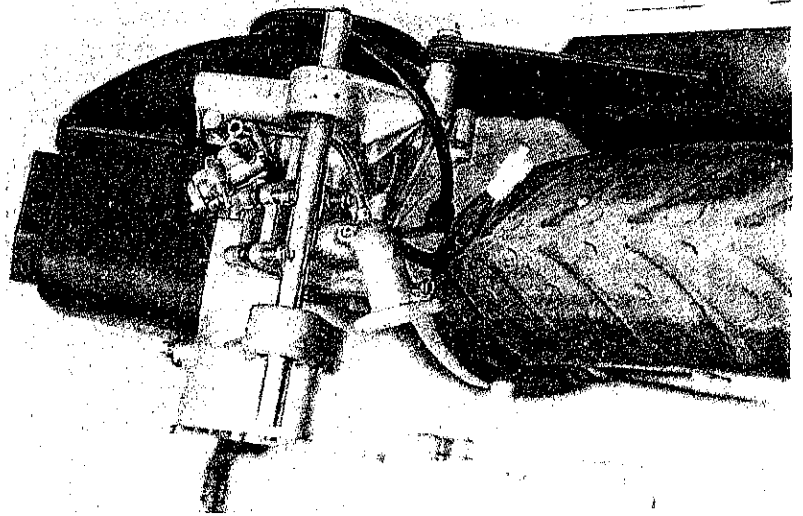

(c) remove locking screw.

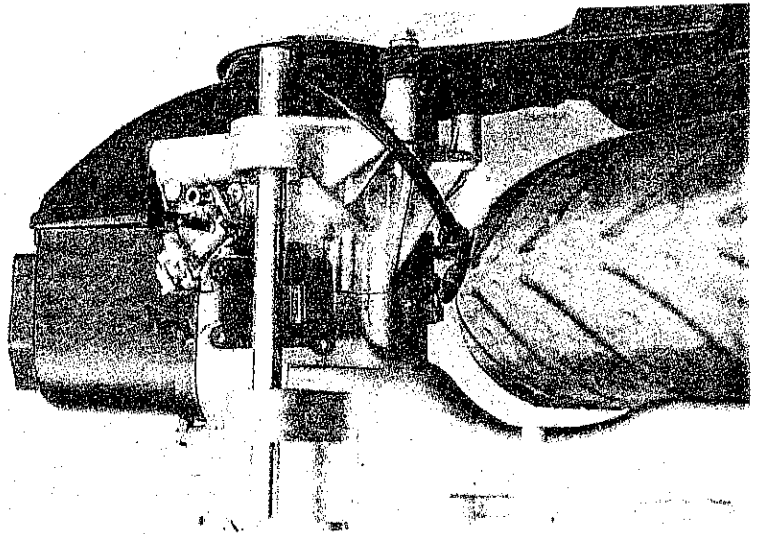

(d) remove air inlet manifold.

(e) remove reed valve.

2. checking the reed valve.  
change a new one when the  
reed valve is worn or d-  
istortion. Also change a  
new one when the base of  
reed valve is cracked,  
injured or distorted.

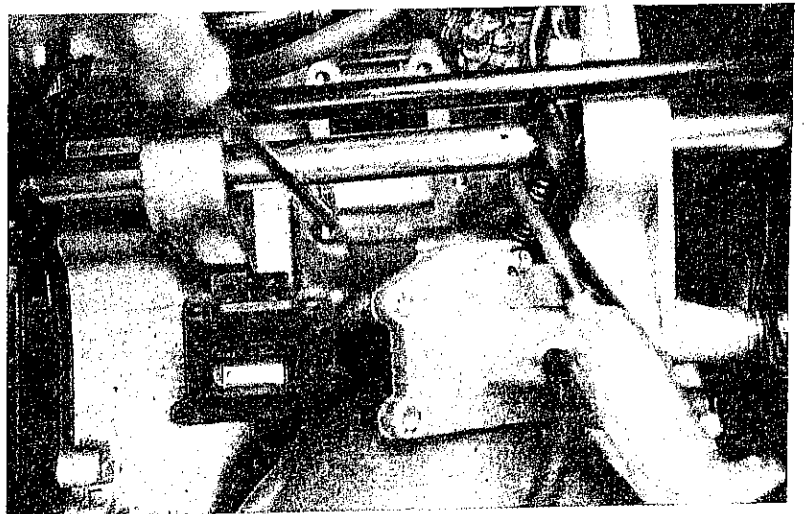

### G. Checking fuel cock:

1. when engine stop, remove the fuel pipe and check is there fuel flow out. It is normal when the residue fuel (5-10cc) flow out from fuel cock and fuel pipe. If it is continue to flow out, the vacuum pipe is blocked, please clean it.

2. remove vacuum pipe from carburetor and suck it to produce vacuum, the fuel should flow out then from fuel pipe, vice versa, if fuel don't flow out follow above operation, please check the folling.

(a) clean out the blockage in vacuum pipe.

(b) blow air to fuel cock inlet pipe.

#### 3. Note:

Use the bowl under the end of fuel pipe to receive the drop.  
Avoid fire even spark.

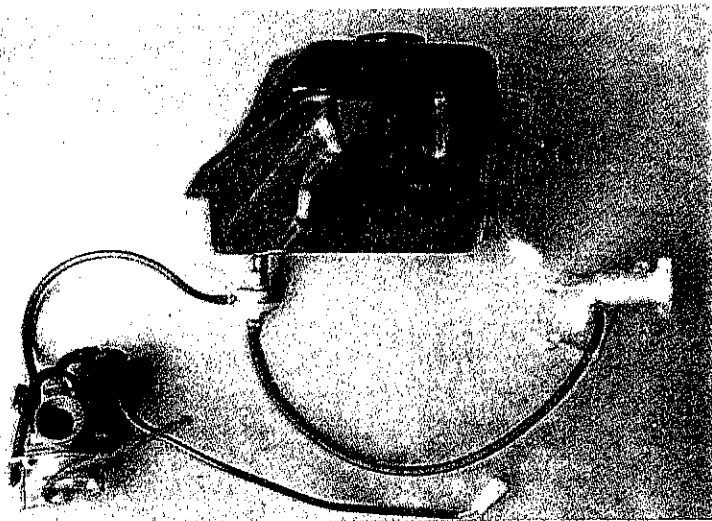

(10)Steering column, front wheel, frt disc brake  
comp, frt drum brake comp, front fork:

- A. troubleshooting
- B. data
- C. change speedometer cable
- D. steering handlebar
- E. front wheel
- F. front brake
- G. front fork

A. Troubleshooting

1. steering handlebar is abnormal, too tight.
  - a. steering mechanism; washer of conical buselocked too tightly.
  - b. steering mechanism; steel ball is cracked.
  - c. steering mechanism; steel ball base and washer of conical base is injured.
  - d. wheel pressure is too low.
2. steering handlebar is aslant.
  - a. left and right damper is not even.
  - b. front fork is crooked.
  - c. the axle of front fork is crooked, wheel is aslant.
3. front wheel swings.
  - a. wheel rim is distorted.
  - b. bearing of front axle too free.
  - c. wheel rib is distorted.
  - d. wheel is not good.
  - e. front wheel axle locked improperly.
4. front damper is too soft, spring fatigue.
5. noise in front damper.
  - a. noise comes from damper box.
  - b. locking screw of damper is slackness.

B. Data

Item	Standard value(mm)	limit of use(mm)
lining of frt brake	4.0	3.0
disk of frt brake	3.6	3.1
swingness of frt/rr wheel		2

C.Changing speedometer cable: .

- 1.Remove the front handle cover.
- 2.Remove the nut of speedometer cable.

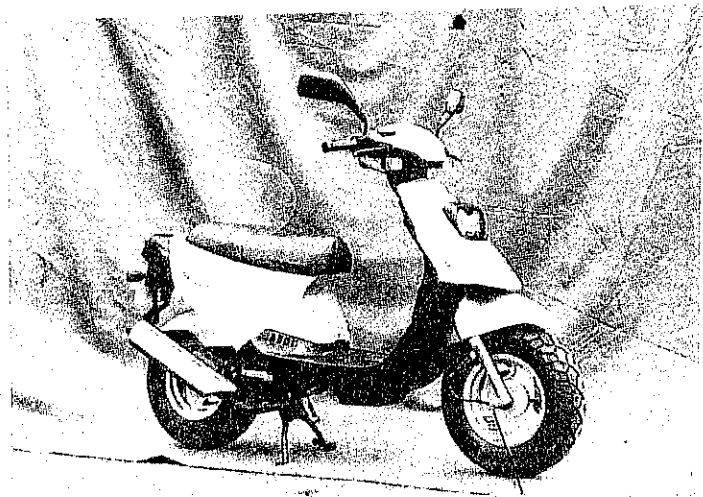
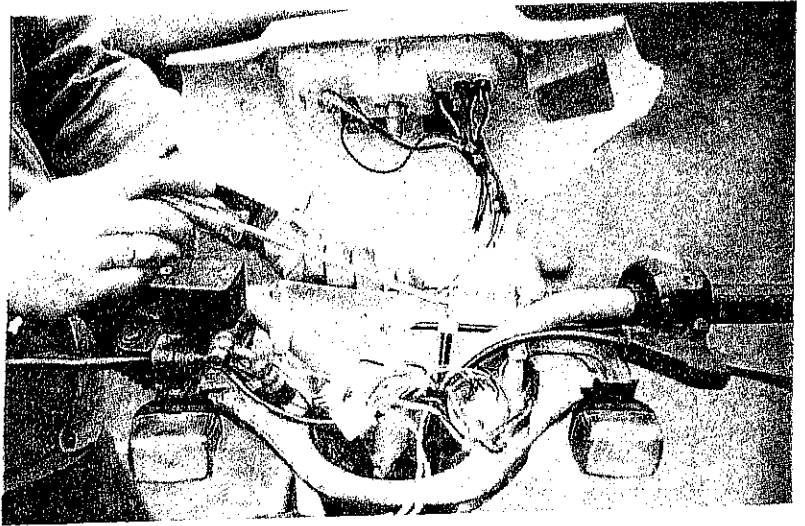

- 3.Remove the fixed screw of speedometer cable on the front right wheel.
- 4.Draw out the damage speedometer cable.
- 5.Assemble the new cable follows the opposite procedure of dismantling.

Note:

Put the grease onto the inner cable before assembling.

D. Steering handlebar.

1. Remove the LH/RH back mirrors.
2. Remove the front handle cover.
3. Remove the rear handle cover, speedometer and plugs of switch.

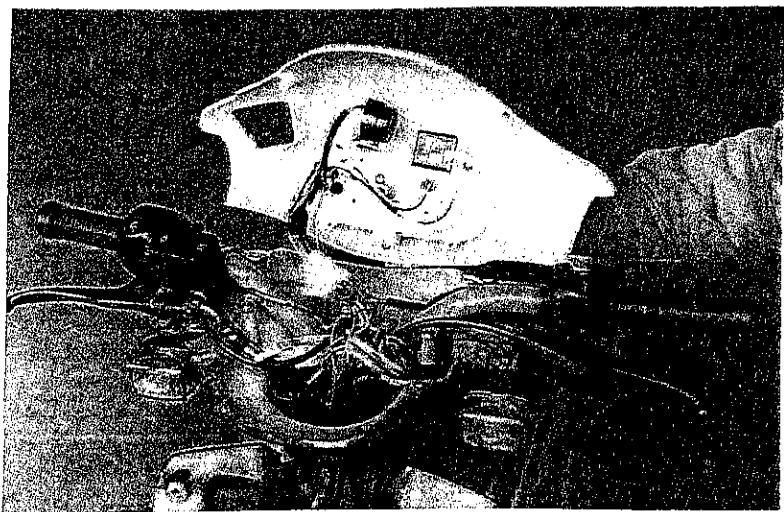

4. Remove the terminal of rear brake cable and the switch plug of rear brake lamp.
5. Loosen the acceleration pulley comp.
6. Remove the throttle cable and RH grip assy.
7. Remove the locking bolt of front brake master cylinder on the steering handlebar, then remove front brake master cylinder.

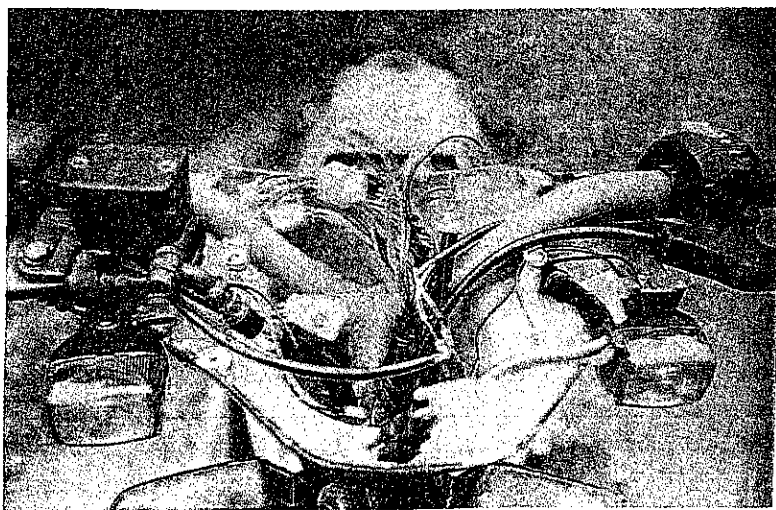



8. Remove the bolts and nuts fixed the handlebar on the front damper.
9. Remove the steering handlebar.
10. Assemble the handlebar follows the opposite procedure of dismantling.  
Locking torque M6:1.0~1.2kg.m M10:3.0~4.0kg.m
11. Put the grease onto the cables before assembling.

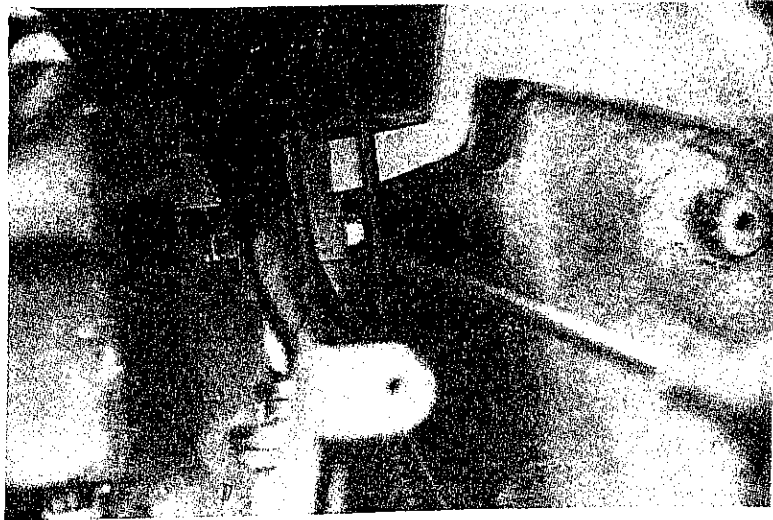

E. Front wheel:

1. Remove the lock nut of front wheel on the right side.

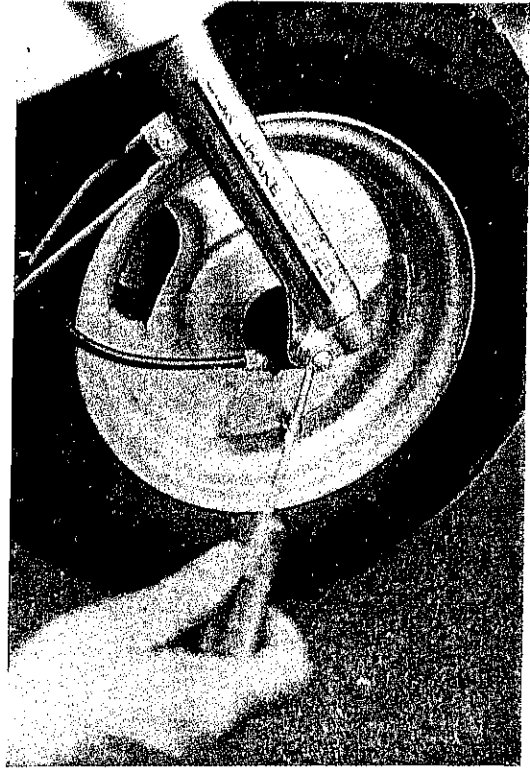

2. Draw out the axle of front wheel, remove the separated ring and take off the gear sets of speedometer.
3. Remove the front wheel assy.
4. Assemble the front wheel follows the opposite procedure of dismantling.

Locking torque: M10: 3.0~4.0 kg.m

Note: 1. Put the braking block of speedometer gear assy upon the extension of the frt fork.

2. Put the grease onto the gear sets of speedometer before assembling.

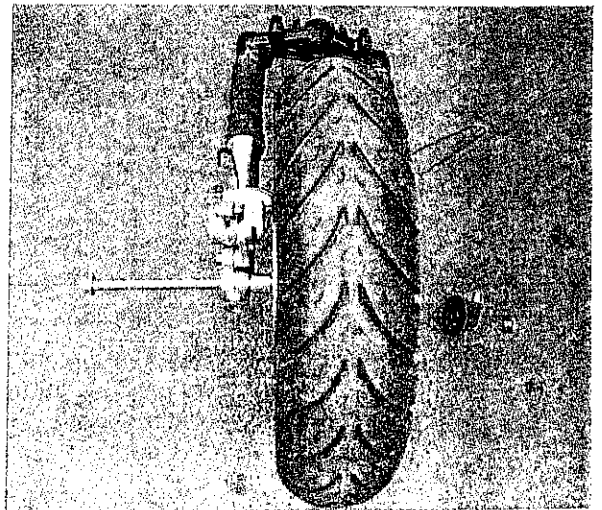

5. Checking front axle

- a. check the currentness of front axle.
- b. limit of use: change it as it is above 0.2mm

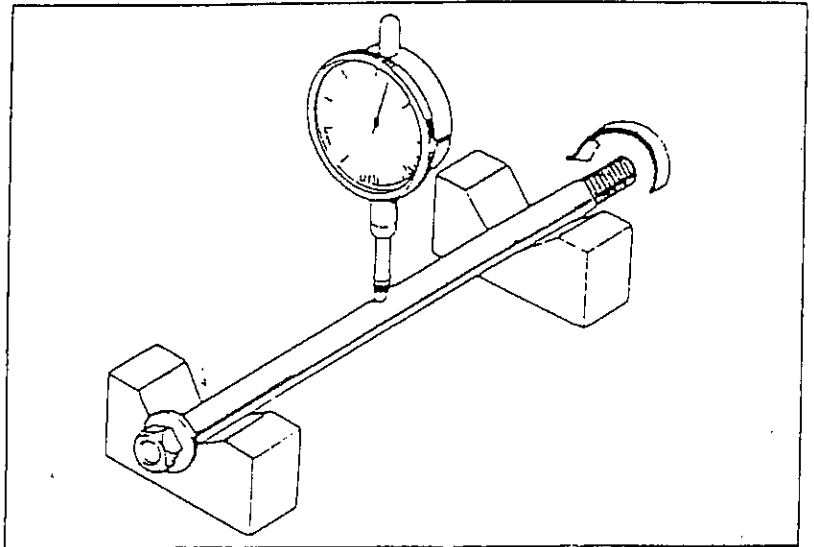

6. Checking the bearing of front wheel, rotate the wheel, if noise or slack occur in bearing, please change a new one.

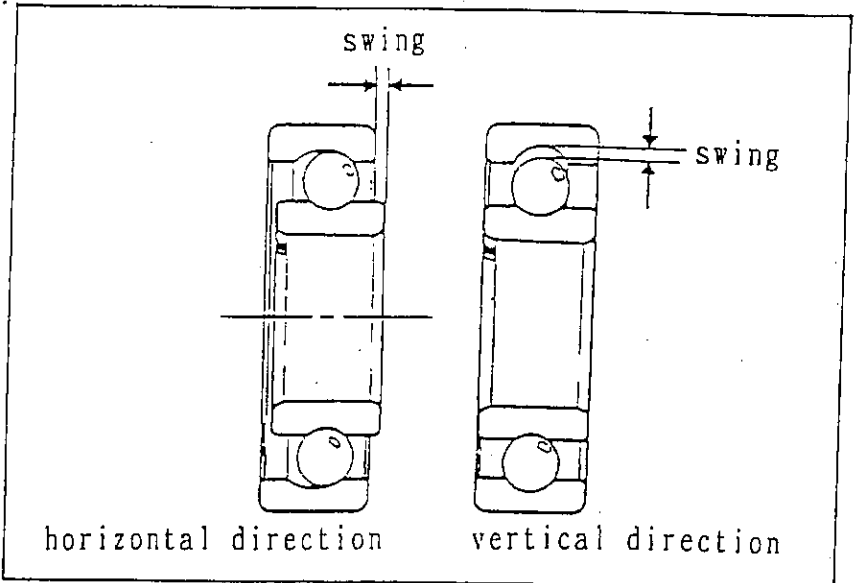

7. Front wheel rim checking  
(a) check the swingness of front wheel rim.  
(b) limit of use:

- horizontal direction: change a new one when it is above 2.0mm.
- vertical direction: change a new one when it is above 2.0mm.

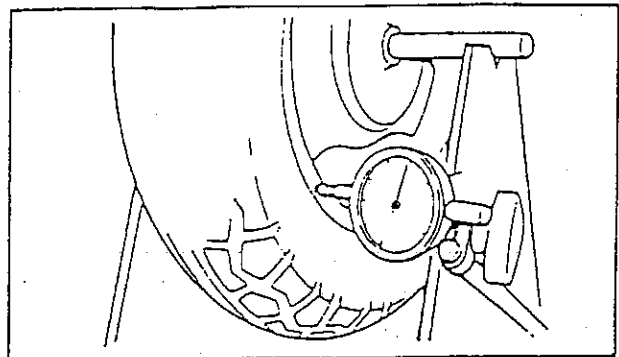

(F)Front brake

1.System diagram of front brake

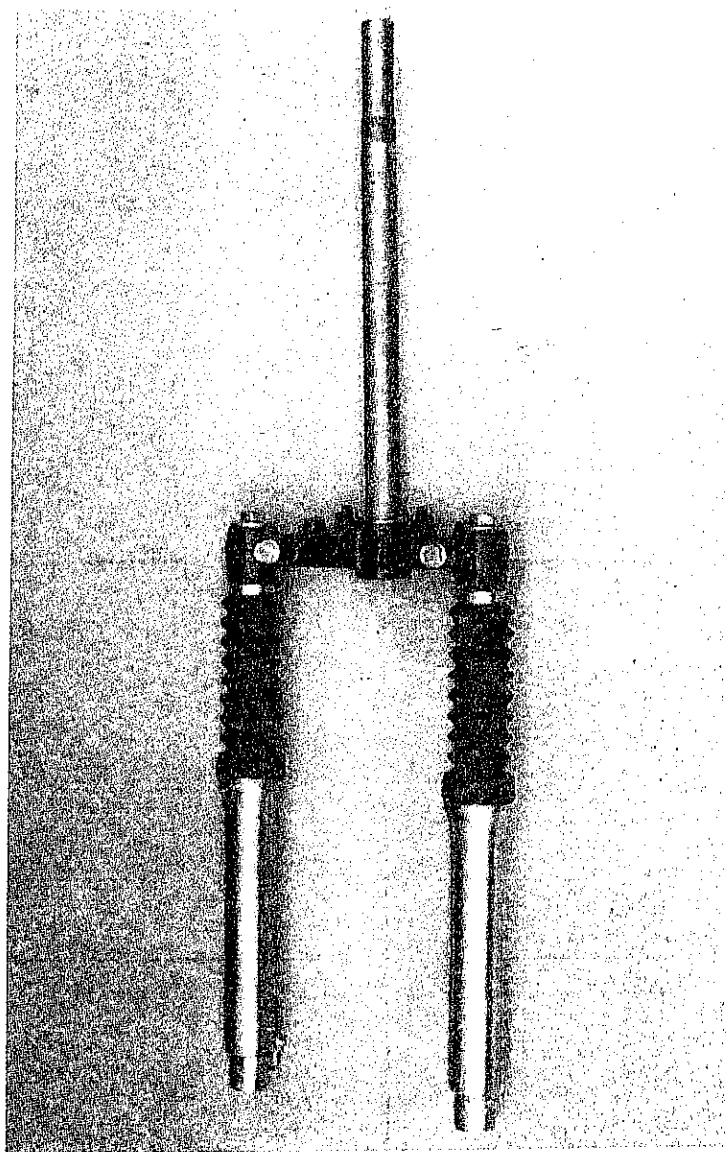

## 2. Disassembling and assembling front brake comp.

a. remove two bolts fixed the frt. brake comp. on the front fork.

b. remove the front brake comp.

c. assemble the frt brake comp. follows the opposite procedure of dismantling.

locking torque:

M8: 2.0~3.0kg.m

## 3. Air leakage of front brake comp.

The procedure of air leakage

a. inject proper brake oil to the storage tank.

b. Don't let the brake oil overflow from master cylinder or storage tank when assemble the master cylinder cover.

c. Put the spanner upon the leaking screw for cylinder.

d. Lock and unlock the screw several times fill there is no bubble.

e. Operate slowly the brake lever several times.

f. Push the brake lever to the end.

g. Loose the leaking screw, then move forward the lever to the limit.

h. Locking the leaking screw and then loose it when the lever on the end.

i. Repeat the above procedure until all of the air of brake system was leaked completely.

locking torque of leaking screw: 0.6kg.m

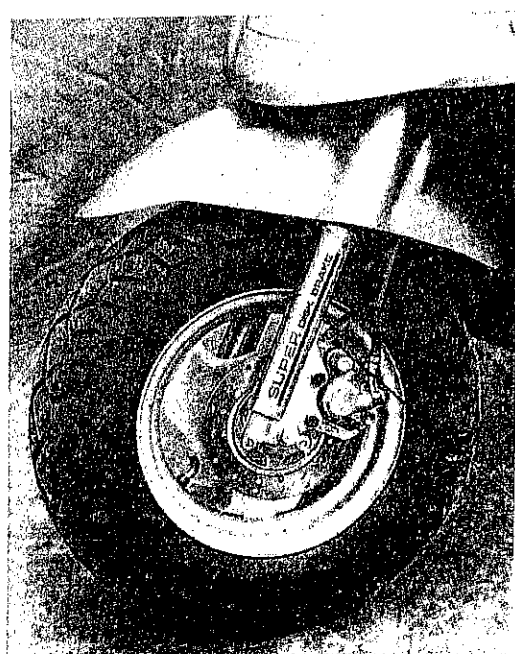
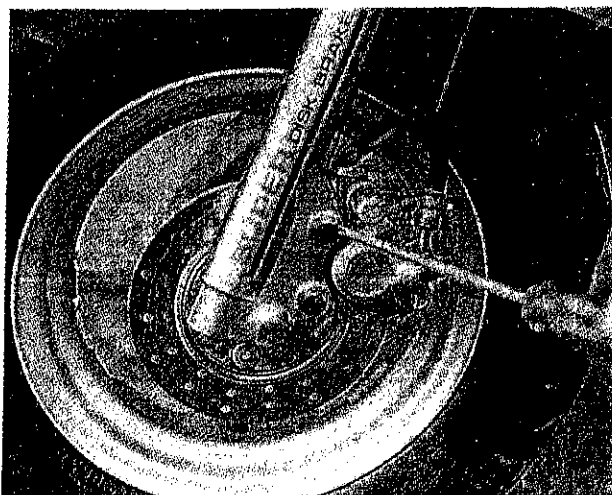

4. Disassembling and assembling the front brake-disk.

- a. Remove the front wheel.
  - b. Remove three nuts on the disk.
  - c. Remove the disk.
  - d. Assemble the disk follows the disassembling procedure.
- locking torque M8:2.0~3.0kg.m

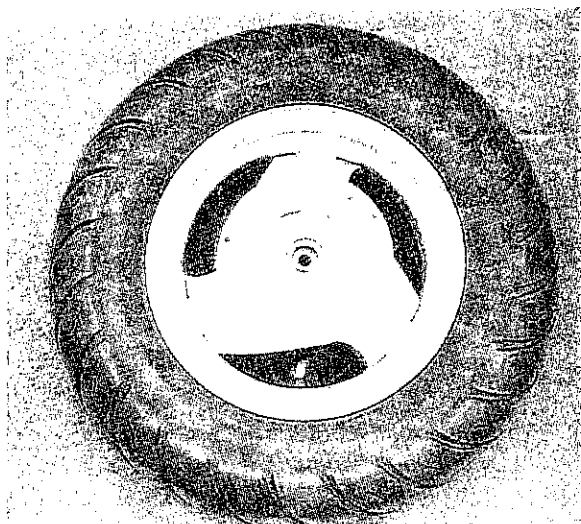

5. Checking the front brake-disk.

Standard thickness of disk : 3.6mm  
limit of use:change it as below 3.1mm

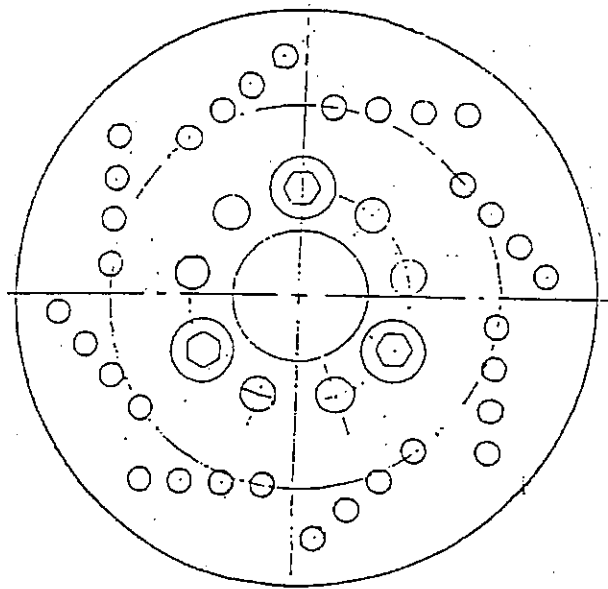

6. Checking the front brake-lining.

a. Standard thickness:4.0mm.  
limit of use:As the thickness is below  
3.0mm,change it.

Note:Prevent grease on the lining.

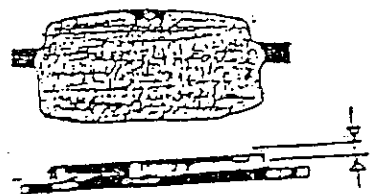

(11)Rear wheel , rear brake , rear damper :

- A. troubleshooting.
- B. data.
- C. dismantling the rear wheel.
- D. checking the rear wheel.
- E. rear brake.
- F. rear damper.

A. Troubleshooting.

1. Rear wheel swings.
  - a. wheel rim is distorted.
  - b. wheel is abnormal.
  - c. unproperly assemble the wheel axle.
2. Rear damper is too soft
  - a. rear damper spring fatigue.
3. Bad braking
  - a. the adjustment of brake is not good.
  - b. the brake lining is dirty.
  - c. the brake lining is worn out.
  - d. the cam of brake lining is worn out.
  - e. the brake cam lever is worn out.
  - f. the brake hub is worn out.
  - g. the assembling of brake lever gear trough is not good.

B. Data

Item	Standard value(mm)	limit of use(mm)
The swingness of rear wheel	—————	2.0
Brake bub inner diameter	110	110.5
Thickness of brake lining	4.0	2.0



### C. Dismantling and assembling the rear wheel.

1. Remove the rear mudguard.
2. Remove the muffler.
3. Remove the nut on the rear wheel.
4. Remove the rear wheel.
5. Assemble the rear wheel follows the dismantling procedure.

Locking torque: M6: 0.7-1.1 Kg.m

M14: 8.0-10.0 Kg.m

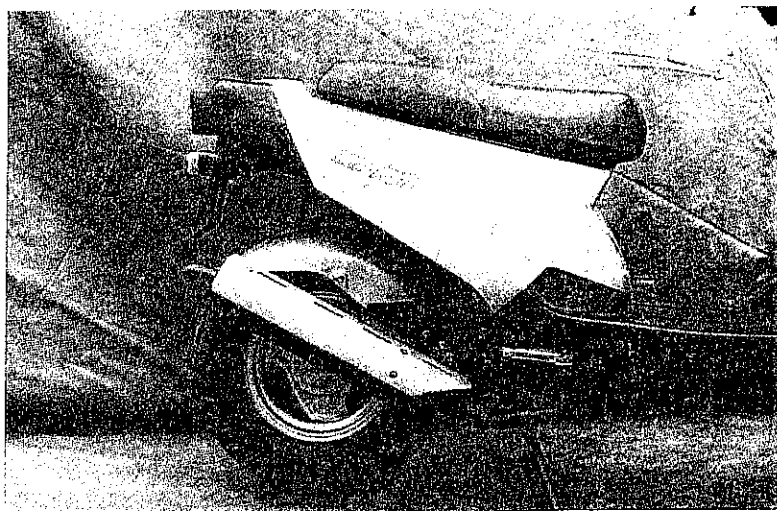

### D: Checking the rear wheel.

check the swingness of rear wheel.

radial direction:

change it as it is above  
2.0mm.

horizontal direction:

change it as it is above  
2.0mm.

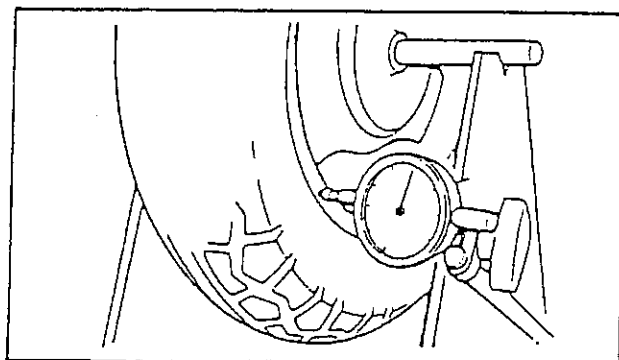

E.Rear brake:

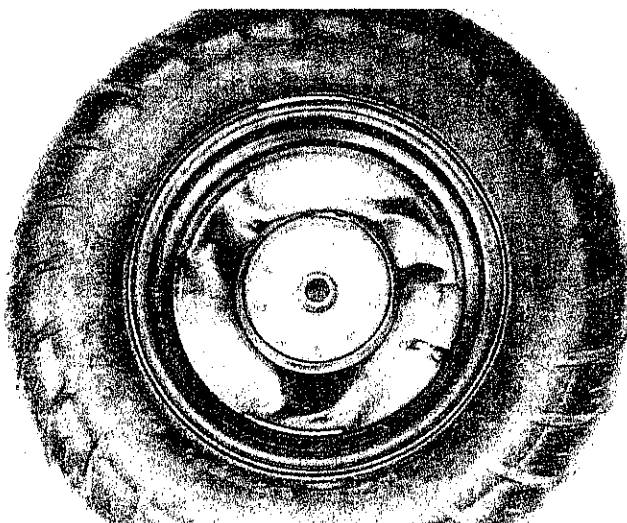

1. Rear brake disassembling diagram.

(1) Checking rear brake hub:

- a. measure the inner diameter of rear brake hub.
- b. limit of use:change it as the diameter is above 110.5mm.

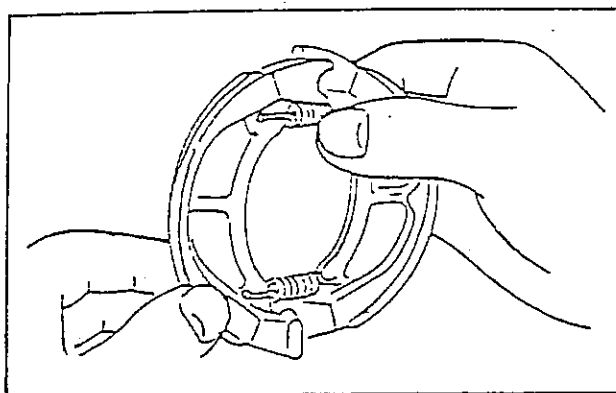

(2) Checking brake lining:

- a. measure the thickness of rear brake lining.
- b. limit of use:As the thickness is less than 2mm, change it.

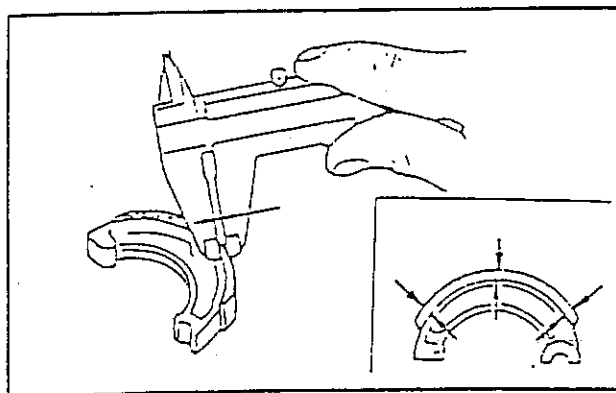

F. Rear damper

1. Rear damper disassembling diagram:

specified torque: 3.0-4.0Kg-m

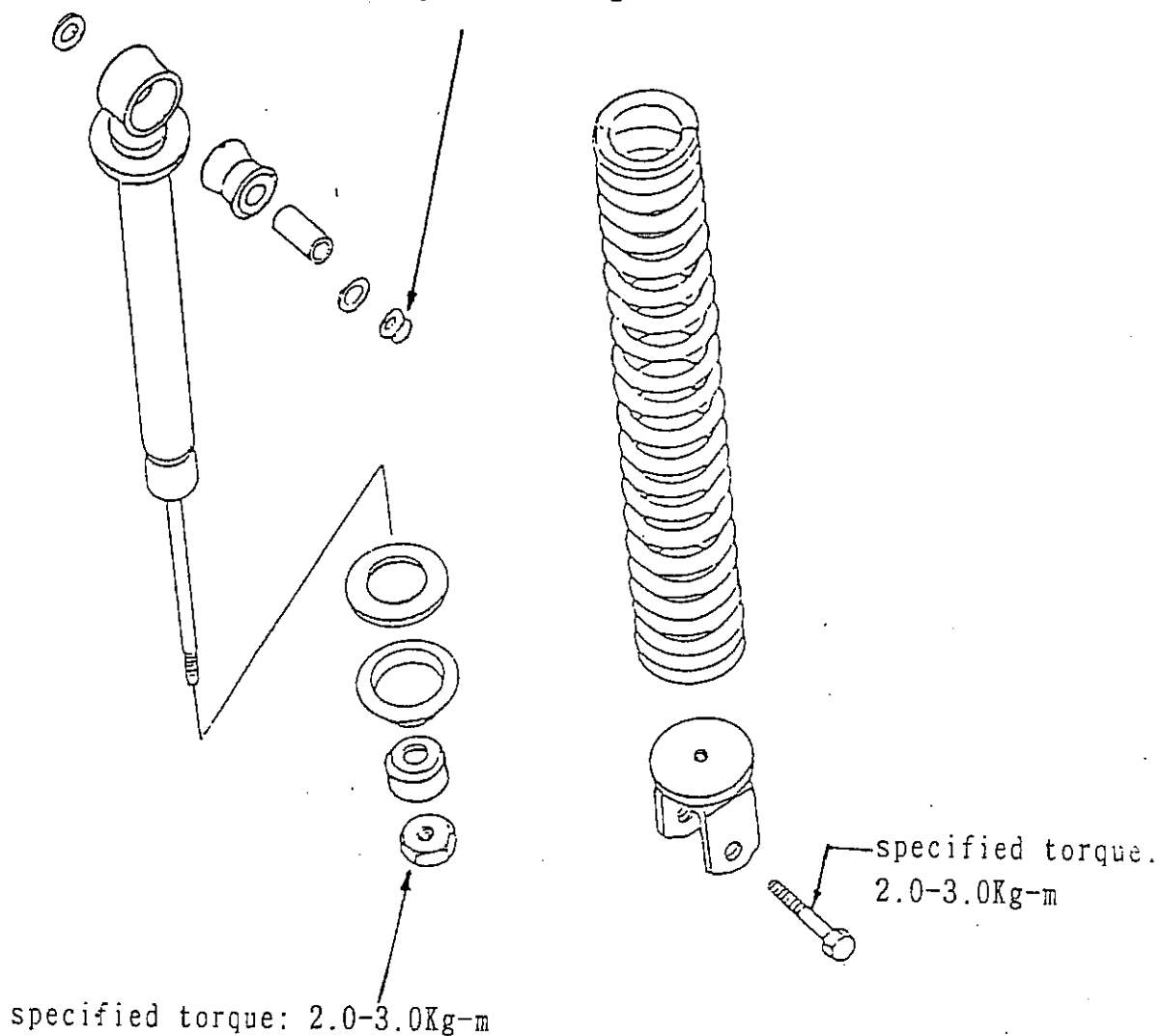

(12)Fuel tank , oil tank :

- A. Troubleshooting.
- B. Fuel tank disassembling diagram.
- C. Dismantling and assembling feul tank.
- D. Oil tank disassembling diagram.
- E. Dismantling and assembling oil tank.

A. Troubleshooting:

1. Engine can't be started:
  - a. No fuel in fuel tank.
  - b. Fuel pipe is blocked.
  - c. Auto cock and fuel filter is blocked.
  - d. The membrane of fuel cock over extended.
2. The mixture is too lean.
  - a. Ventilation hole is blocked.
  - b. Fuel pipe is crooked, squeezed, or blocked.
  - c. Auto cock and fuel filter is dirty.

(B) Fuel tank

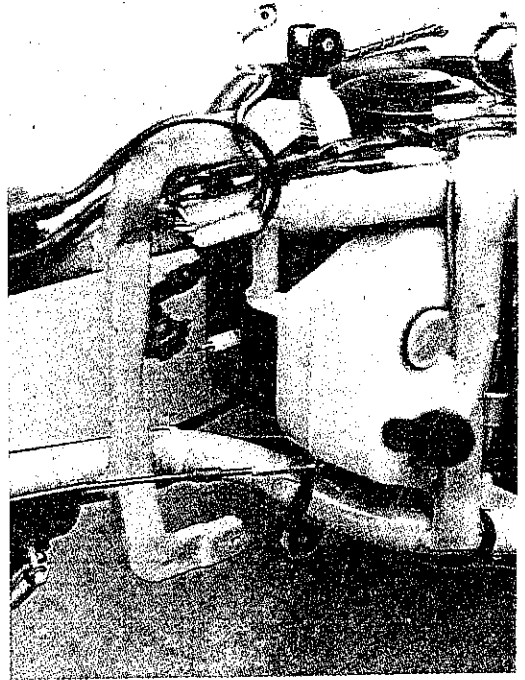
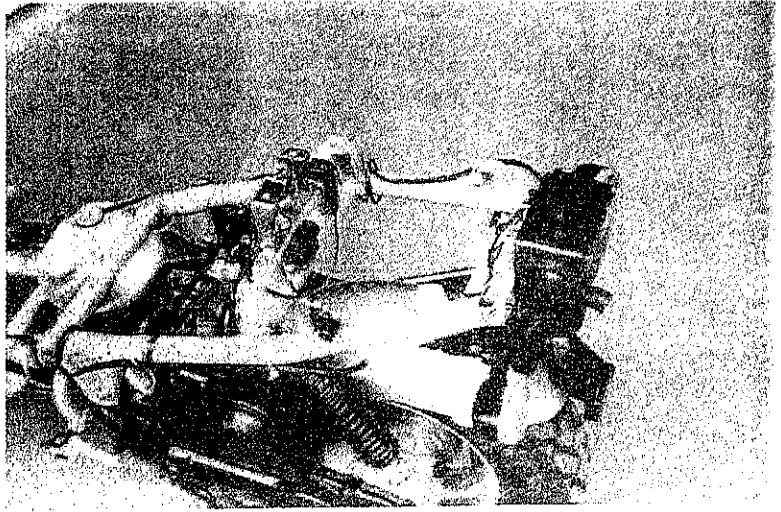

C. Fuel tank dismantling and assembling

1. Remove the rear carrier(rear protector)

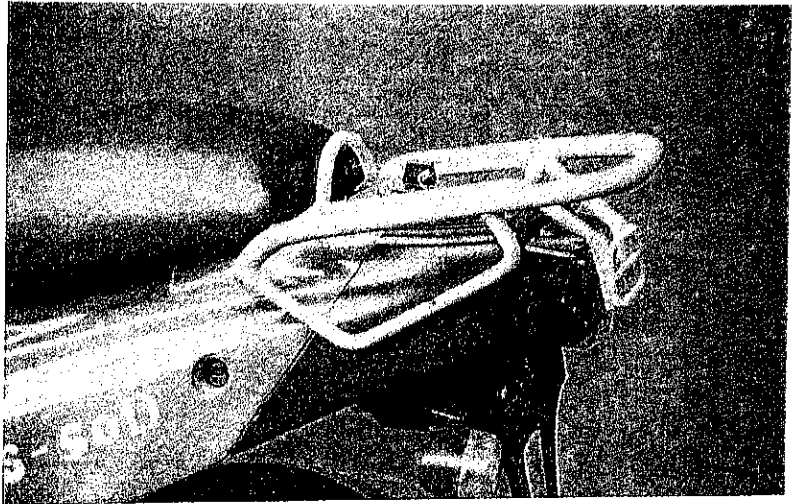

2. Open the seat.
3. Remove luggage box.

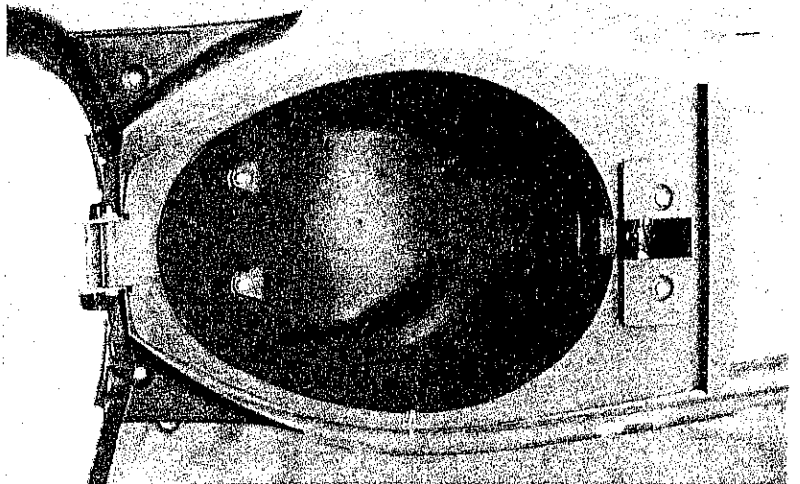

4. Take off the luggage box.

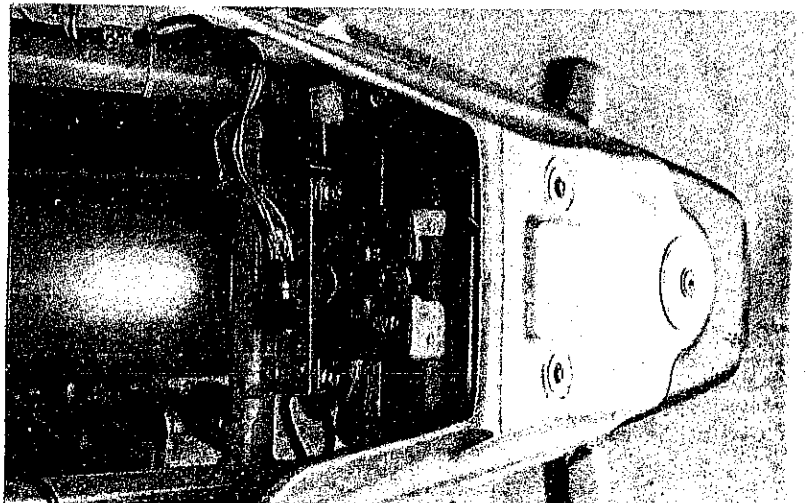

5. Remove the fuel cover and then take off the side cover.

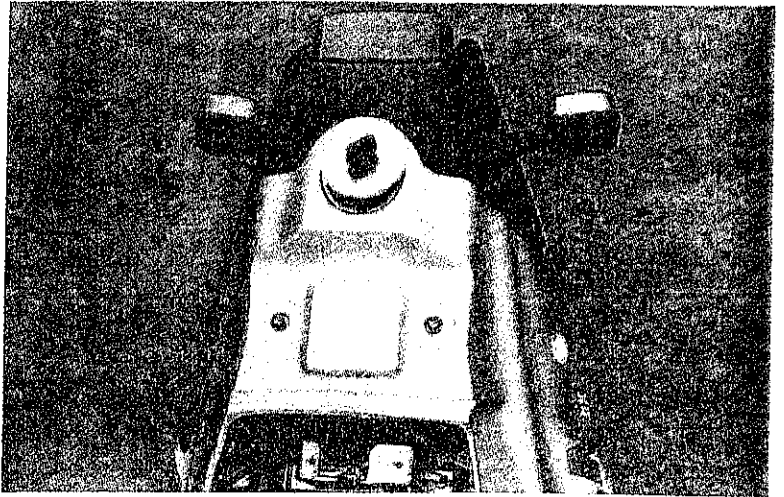

6. Take off the rear lamp cover.

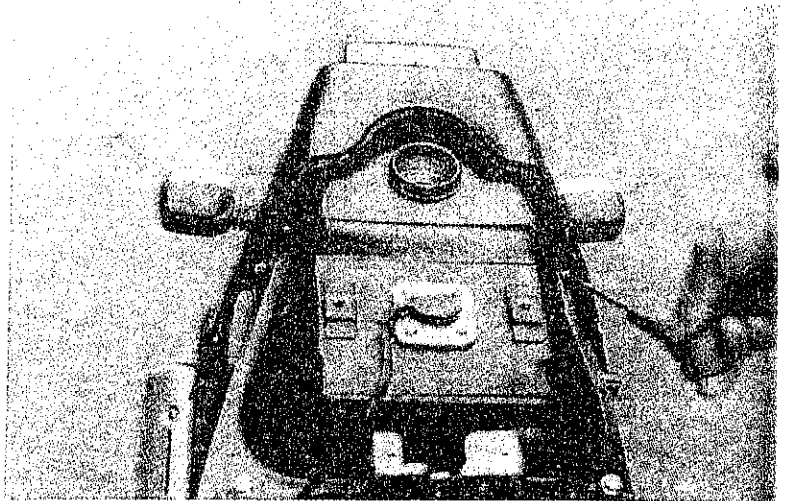

7. Remove the vacuum pipe and fuel pipe from the fuel tank & carburetor.
8. Remove the connecting terminal of fuel gauge.
9. Remove the fixing bolt from the fuel tank.

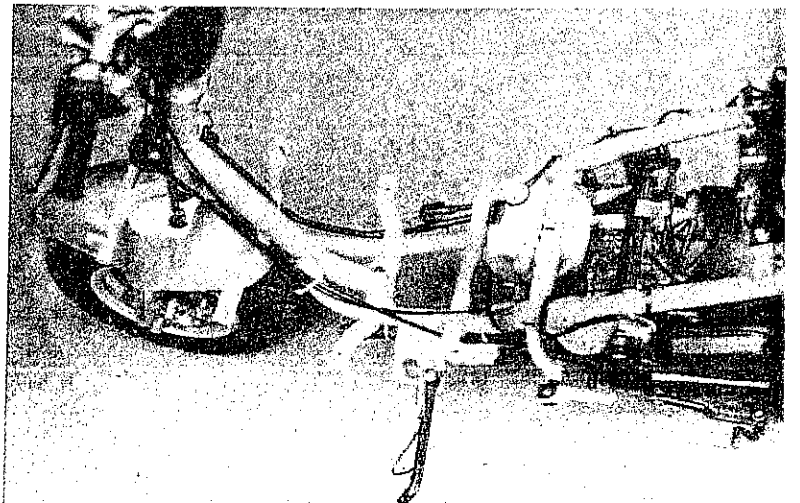



10. Take out the fuel tank.

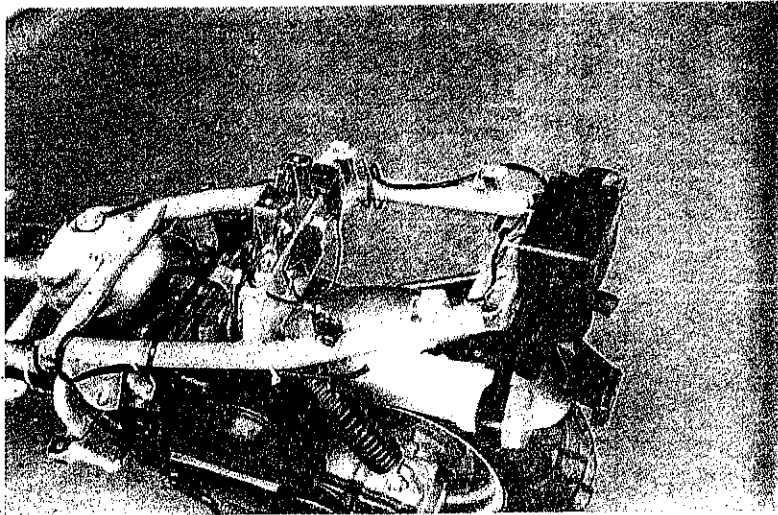

11. Remove the connection terminal of oil gauge.
12. Remove the fixing bolt of oil tank.
13. Take out the oil tank.
14. Re-assembling as the opposite procedure of disassembling. locking torque:  
M6:1.0-1.2 kgf-m

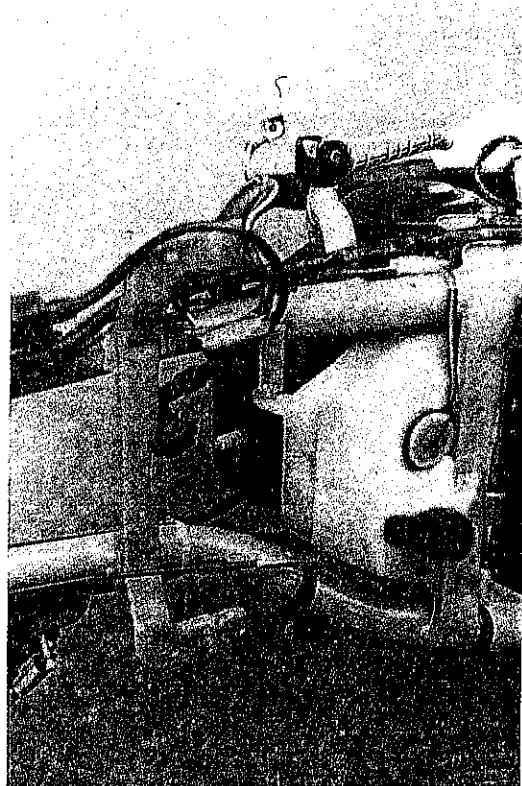

D. Oil tank disassembling diagram:

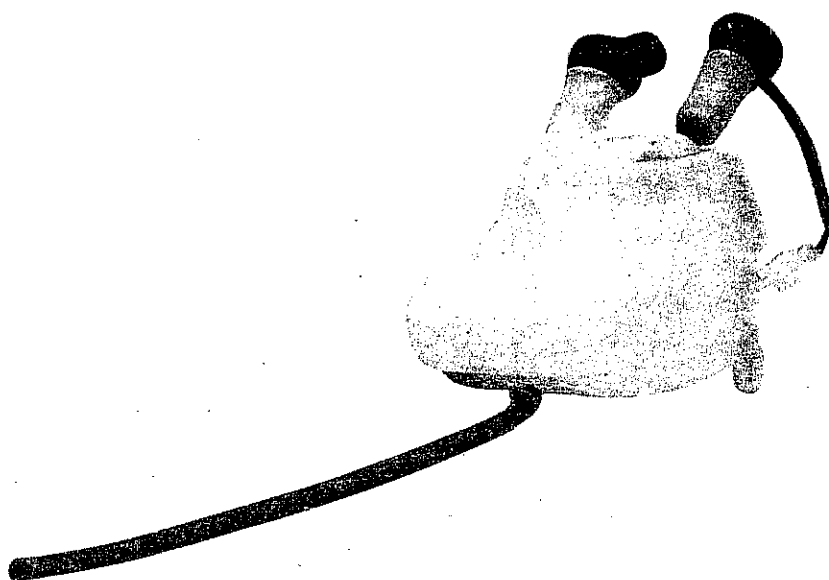

E. Dismantling and assembling oil tank:

1. drain the oil off.
2. remove the cable plug of oil gauge.
3. remove oil tank.
4. clean the oil cleaner.
5. assemble oil tank just in the way oppisite to dismantling.

## 五、Electric equipment:

- (1) Troubleshooting
- (2) Battery
  1. check specific gravity of eletrolyte
  2. recharge
- (3) Recharge system
  1. the wiring diagram of recharge system
  2. check A.C. flywheel magneto
  3. check regulator/rectifier.
- (4) Ignition system
  1. the wiring of ignition
  2. check spark plug
  3. check H.T. cable and H.T. coil
  4. check C.D.I. set
- (5) Starting system
  1. the wiring of starting
  2. checking the starter
  3. dismantling the starting motor
  4. checking the starting motor

## (1) Troubleshooting:

### A. Recharge system:

#### a. No power:

1. battery over charge
  - ① No electrolyte in battery.
  - ② Battery becomes white.
  - ③ Short circuit in battery.
  - ④ Regulator
2. the connecting of wire is drop off.
3. fuse is broken.
4. power supply lock is abnormal.

#### b. Voltage is too low:

1. Battery recharges unsufficiently.
2. The connecting is abnormal.
3. Recharge system is abnormal.
4. Regulator

### B. Ignition system:

#### a. The sparking of spark plug is abnormal:

1. Spark plug is abnormal.
2. Wire connects improperly, broken or short circuit.
  - ① between A.C. flywheel magneto and CDI sets.
  - ② between CDI sets and H.T. coil.
  - ③ between CDI sets and main switch.
  - ④ between main switch and spark plug.
3. Main switch is out of order.
4. H.T. coil is abnormal.
5. CDI sets is out of order.
6. A.C. flywheel magneto is abnormal.

### C. Starting system:

#### a. Starting motor can't rotate:

1. The fuse is broken.
2. Battery recharges unsufficiently.
3. Main switch is abnormal.
4. Switch of starting motor is out of order.
5. Switch of front, rear brake is out of order.
6. Starter relay is out of order.
7. Wire disconnects or broken.

#### c. Current is broken:

1. The wiring of battery connects improperly.
2. Ignition system connects abnormally.
3. Ignition system is short circuit.
4. Lamp system connects abnormally or short circuit.

#### d. Abnormal recharge system:

1. The plug part connects abnormally, wire broken or short circuit.
2. Rectifier is abnormal.
3. A.C. flywheel magneto is abnormal.

#### b. Engine rotate unsmoothly:

1. Ignition primary wiring
  - ① the wire or plug of wiring connects improperly.
  - ② main switch disconnects.
2. Ignition secondary wiring
  - ① Ignition coil is abnormal.
  - ② Spark plug is abnormal.
  - ③ H.T. coil is abnormal.
  - ④ Spark plug cover electricity leakage.
3. Ignition period
  - ① A.C. magneto is abnormal.
  - ② A.C.G. coil disconnects.
  - ③ C.D.I. sets is abnormal.

#### 8. Starting motor is out of order.

#### b. Starting motor weak rotation:

1. battery recharges unsufficiently.
2. wiring disconnects.
3. motor or gear some impure material drop in.

#### c. Starting motor can rotate, but engine can't rotate:

1. starting pinion is abnormal.
2. starting motor is reverse rotation.
3. battery is out of order.

## (2) Battery:

Always, remove the battery negative cable(-), then remove positive cable(+). But connect the positive cable(+)first, then connect the negative cable(-)

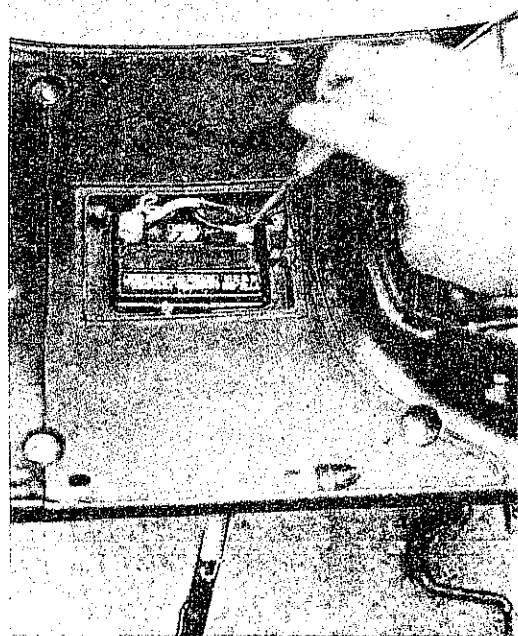
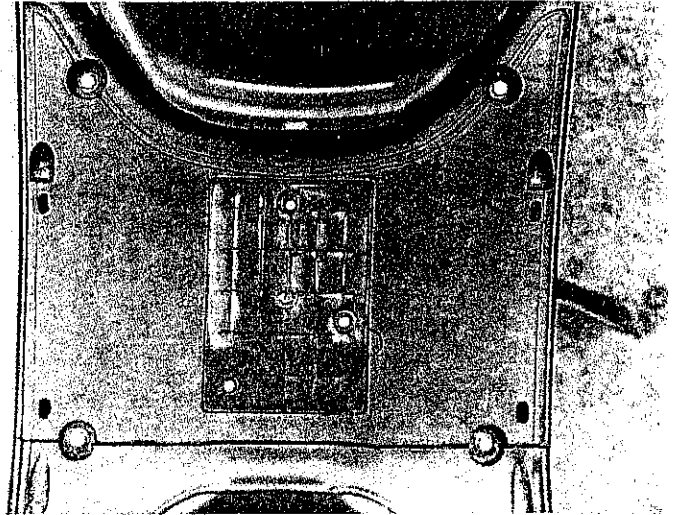

### Note:

- a. Unnecessarily refill the battery liquid.
- b. Do not take out the sealed bolt when recharging.

# 1. Recharge

connection method: recharger positive cable(+) connects with battery positive cable(+).

recharger negative cable(-) connects with battery negative cable(-).

recharge current:

1. Please recharge according to the following current and time.

standard: 0.4\*5-10hrs

rapid: 4A-30min

- avoid fire around the battery.
  - recharge current "ON" or "OFF" should be operated by recharger's switch.
- If suddenly disconnect or connect plugs sparks will occur and explosion will result.

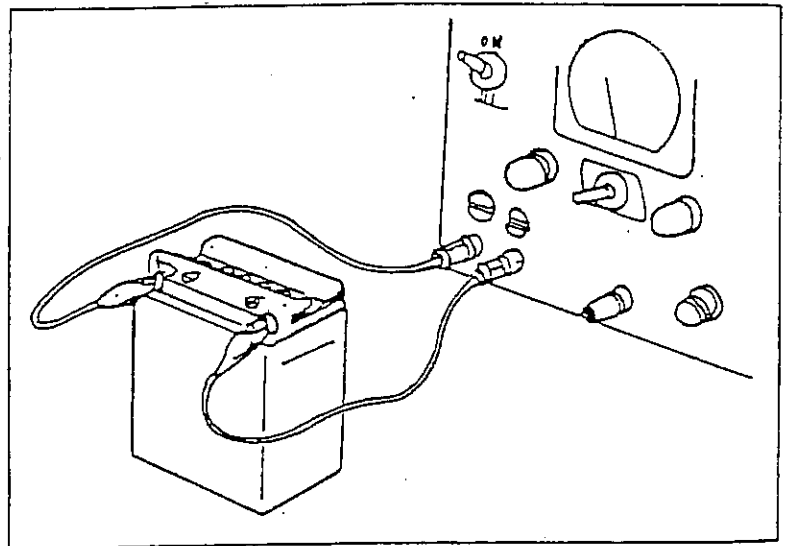

Notice: Avoid using rapid recharge method because it will cause battery broken or to reduce the life of battery.

## Recharge system

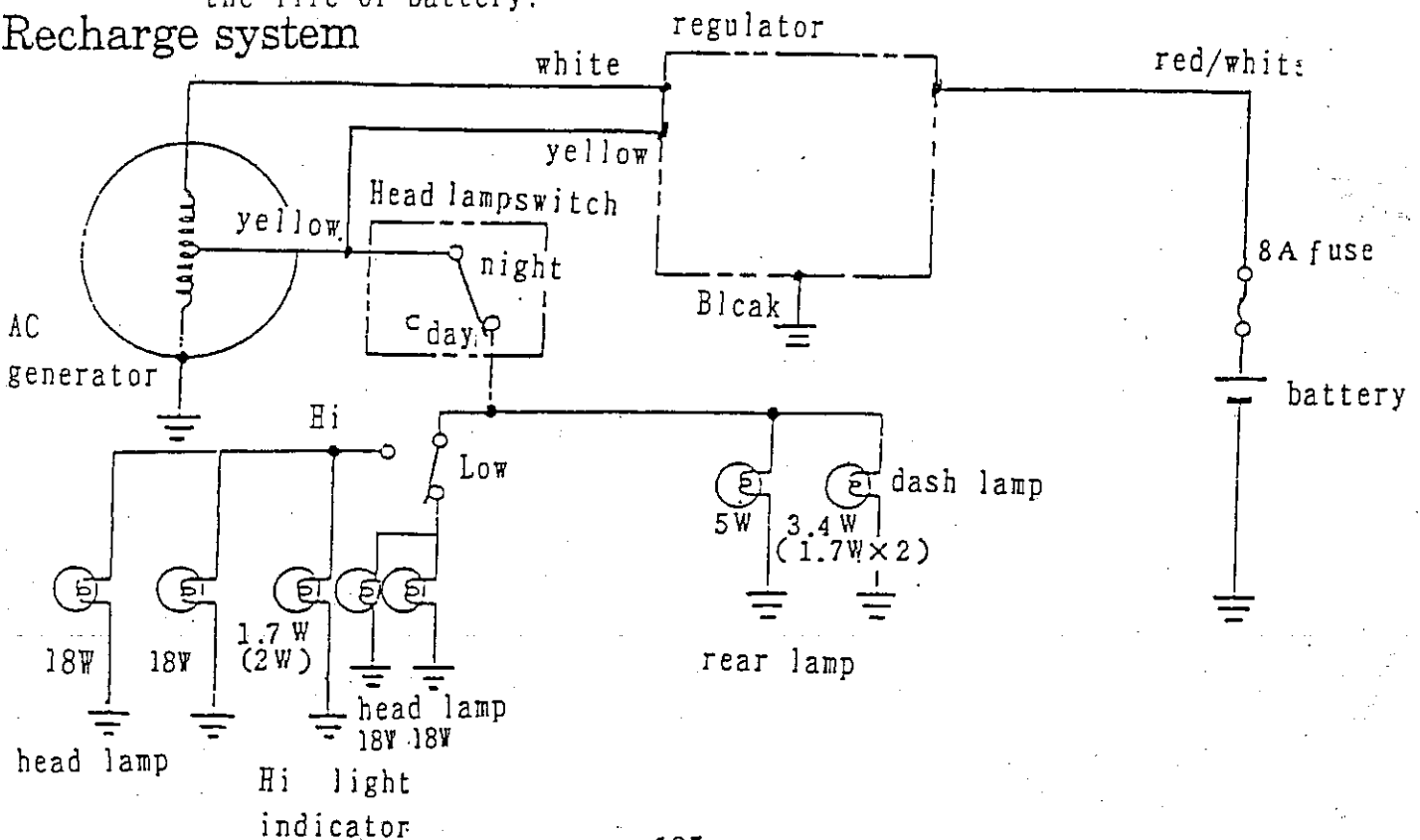

## 2. Measure recharge performance.

This test is performed when the battery had been fully recharged.

When performing this test, engine should be warmed up, remove the luggage. remove the orange wire of regulator. open fuse box, take off red/white wire. Connect galvanometer between red/white wire and fuse.

Red wire connected to galvanometer should not touch the chassis when being tested.

Head lamp switch is "OFF", the rpm of engine is 2000rpm, then test it.

Head lamp switch	recharge start, rpm	2,500rpm	6,000rpm
OFF(day)	below 1,800rpm	above 0.7A	below 1.3A
ON (night)	below 2,000rpm	above 0.5A	below 1.3A

When you can't get the standard value, check the regulator.

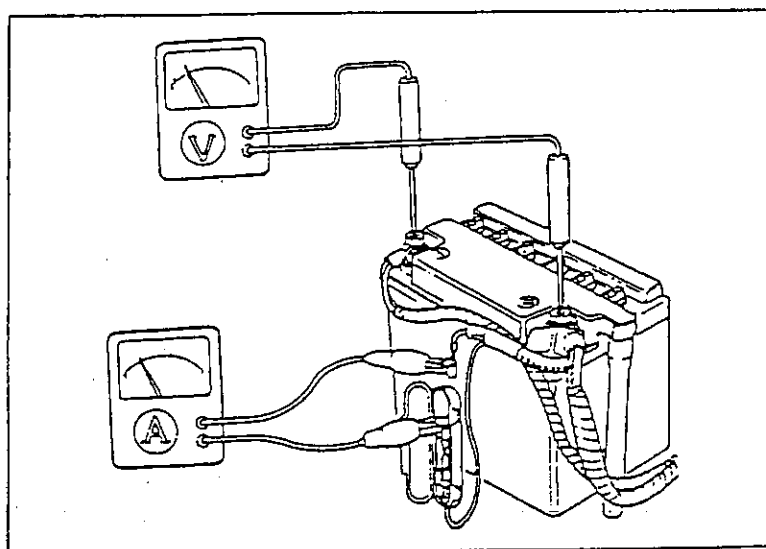

2. Check A.C. flywheel magneto.
  - a. Remove the LH side strip and LH body cover.
  - b. measure the resistance value of terminals.

yellow	black	0.1-1.0
white	black	0.2-2.0

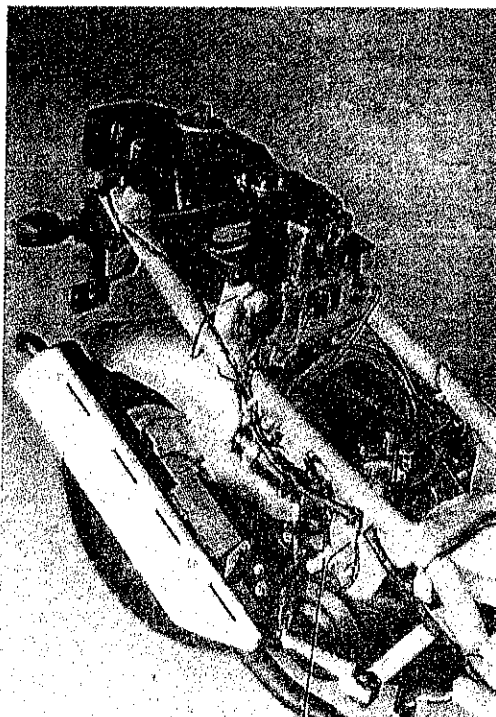

AC Magneto terminal

3. Check regulator measure the resistance value between each terminal, it should be in specified range, otherwise change a new one.

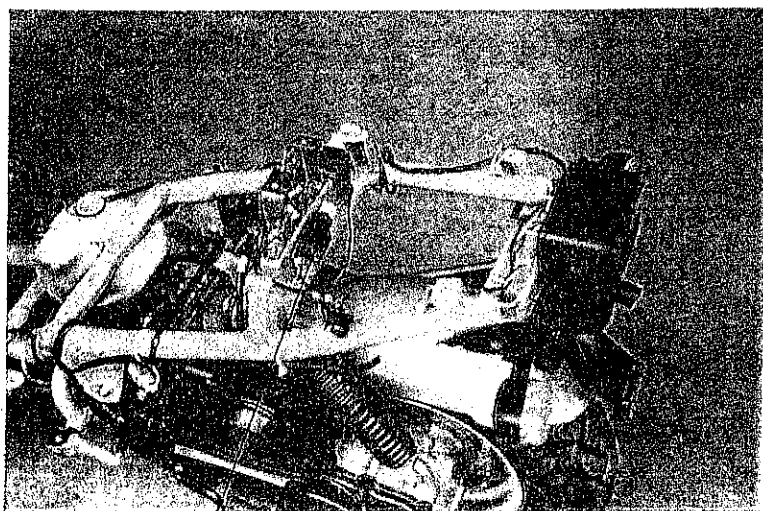

Regulator



## (4). Ignition system:

### 1. the wiring of ignition

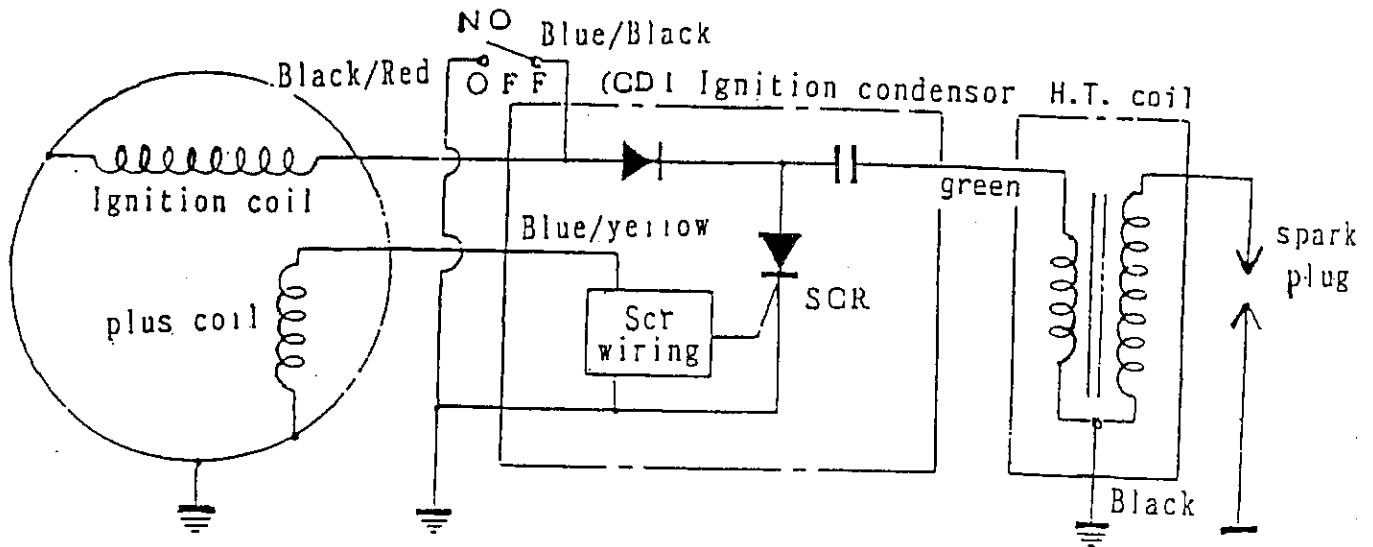

2. check spark plug.

3. check H.T. cable and H.T. coil.

check with CDI tester, follow the instruction manual.

4. check CDI sets.

check with CDI tester and follow the instruction manual.

If CDI is brokendown, please change a new one.

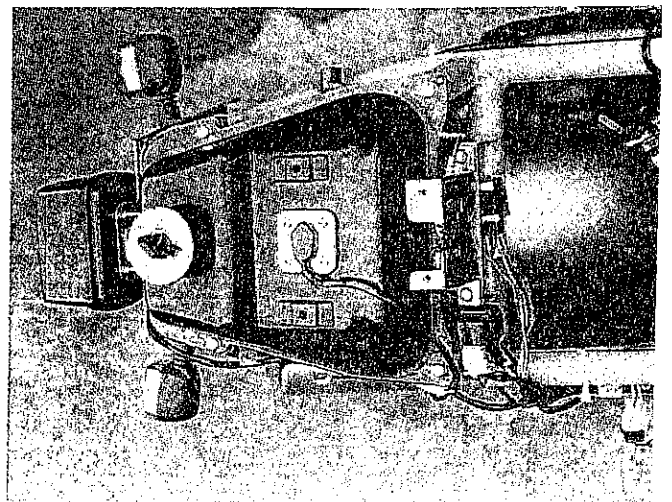
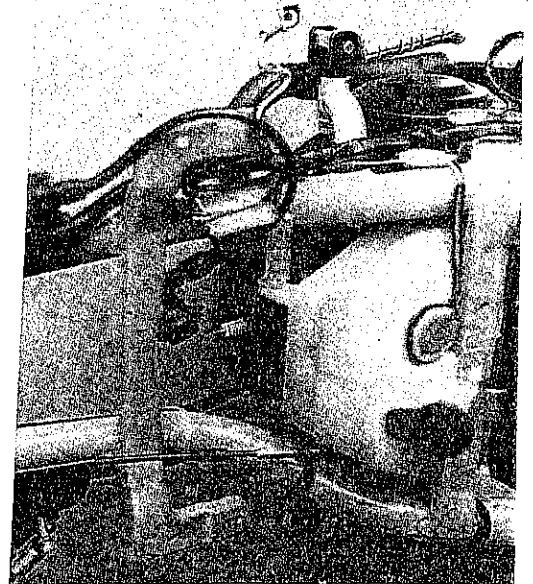

(5) The starting system :

1. The wiring of starting

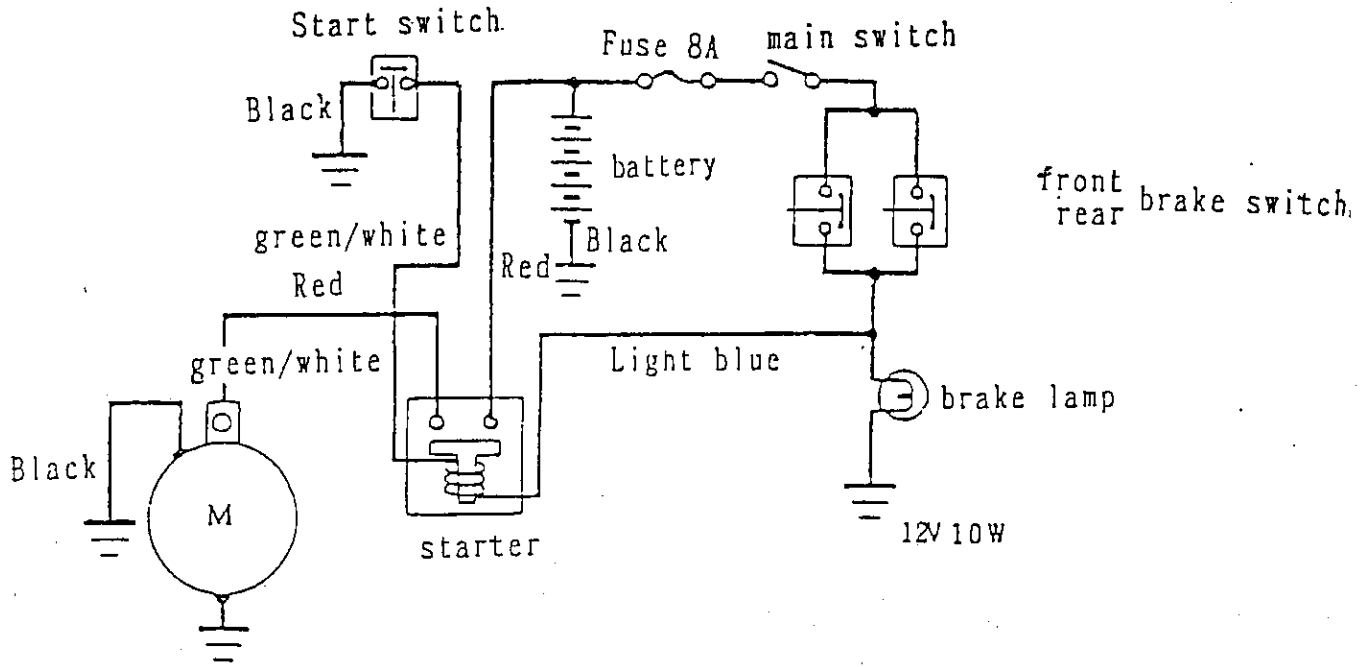

2. check the starter  
 connect green/white + black  
 -with 12v battery if it is and  
 red with black is then it  
 is good.

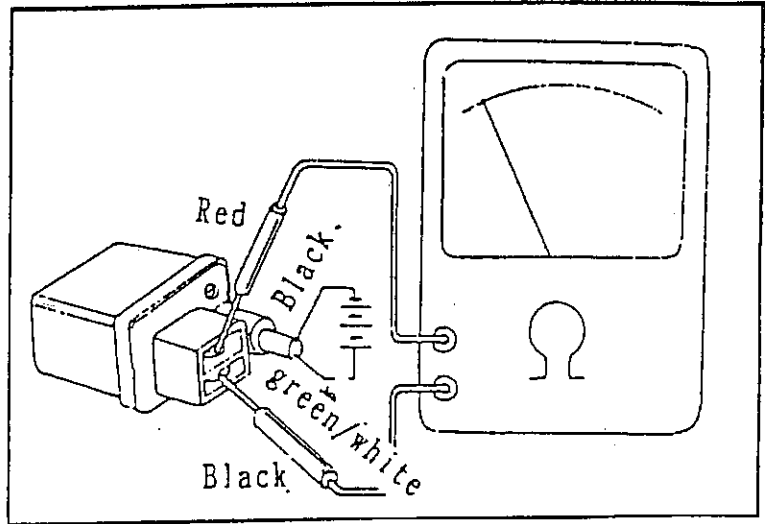

3. dismantling the starting motor
  - (a) remove 2 screws on starting motor.
  - (b) remove starting motor cables.

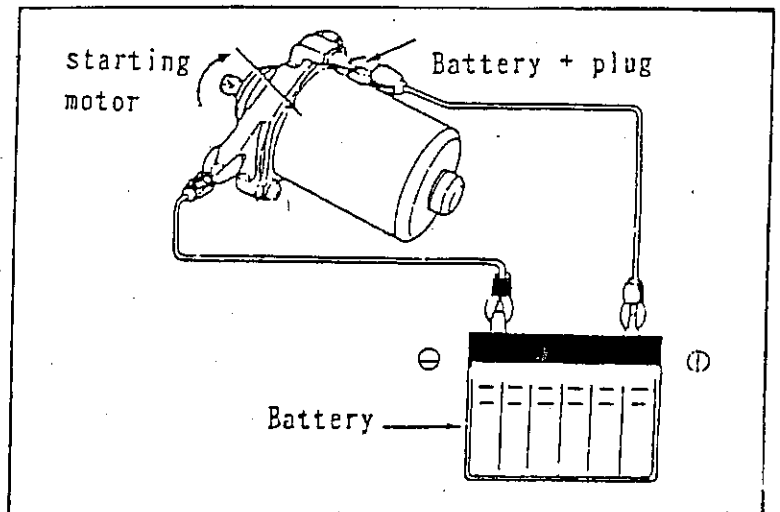

4. checking the starting motor check the operation condition.  
 when connecting starting motor with battery.  
 (watch if it is rotating ccwly)

Do not operate starting motor for too long.



EXPOPT OFFICE  
SOCIETE COMMERCIALE EURO-TAIWANAISE  
3RD FLOOR, NO.112 CHUNG SHAN N.RD.  
SEC 2, TAIPEI, TAIWAN, R.O.C.

MANUFACTURED BY MPI (MOTIVE POWER INDUSTRY CO., LTD.)  
AN ISO 9001 CERTIFICATED COMPANY  
P1-351000001 1999.5