

## **2-STROKE Engine dismantle, maintenance, repair and assembly:**

- (1) Lubrication system
- (2) Engine dismantling
- (3) Drive pulley, starter, clutch,
- (4) Cylinder and, piston
- (5) AC Generator
- (6) Final transmission mechanism
- (7) Crankcase, crankshaft.
- (8) Carburetor, reed valve

## (1)Lubrication system and oil pump

### 1.Lubrication system diagram.

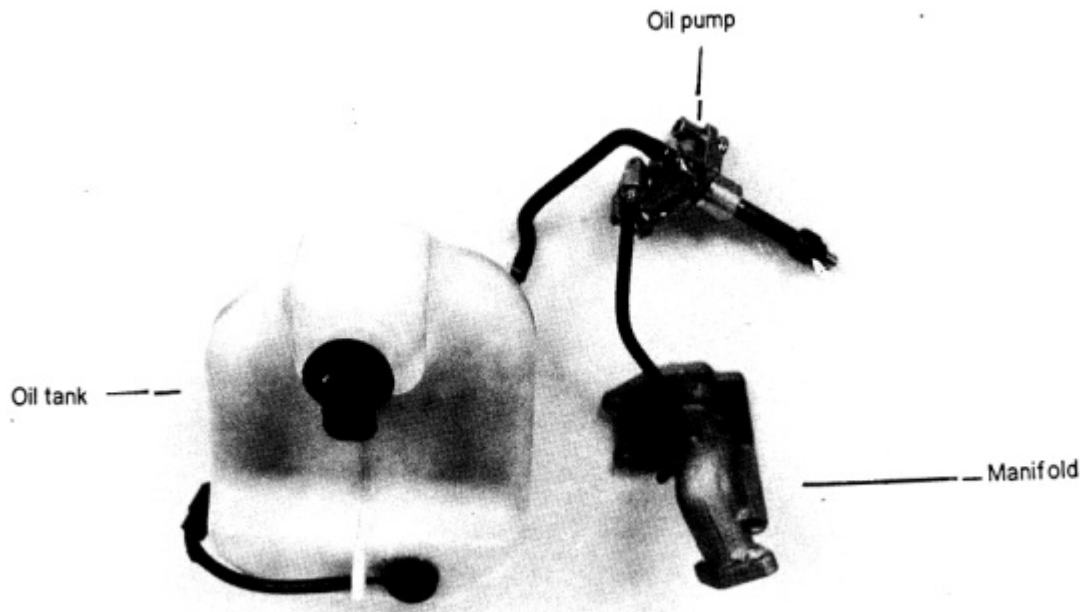

#### B. Engine over heating:

- a. The adjustment of oil pump is not properly.(lack of oil)
- b. The quality of oil is not good.

#### C. Piston over burning.

- a. There is air in the oil pump system.
- b. Oil pump is out of order.

#### D. The route from oil tank to oil pump is blocked.

- a. Ventilation hole on the tank cover is blocked.

Note:1.When removing oil pump, do not drop any unexpected objects into the oil pipe.

2.Please release the air if there is air trapped in the oil pipe.

3.Locking torque of oil pump:0.8-1.2kg·m

### 3. Removing the oil pump.

Clean the oil pump and Crank case before operation

- a. Remove the luggage.
- b. Remove the input/output oil pipe.
- c. Take out the oil pump by removing The locking screw on oil pump and Oil gauge cable.

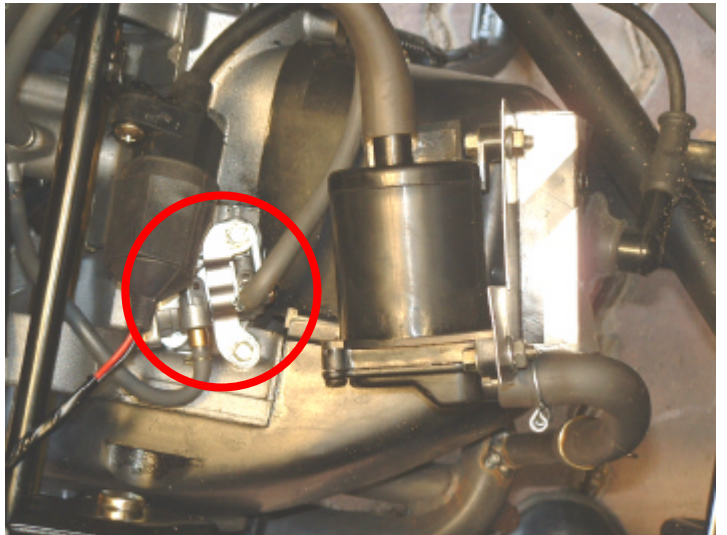

### 4. check the oil pump.

Remove oil pump and check:

- a. O-ring is distorted or not.
- b. contact area of crankcase is injured or not.
- d. Oil pump body is damaged or not
- e. The movement of control lever is free or not (110 cc model only)
- f. The gears are damaged or not.
- g. Check seal and see if there Is oil leakage or not.
- h. Never dismantle oil pump, it can not function well after dismantling.

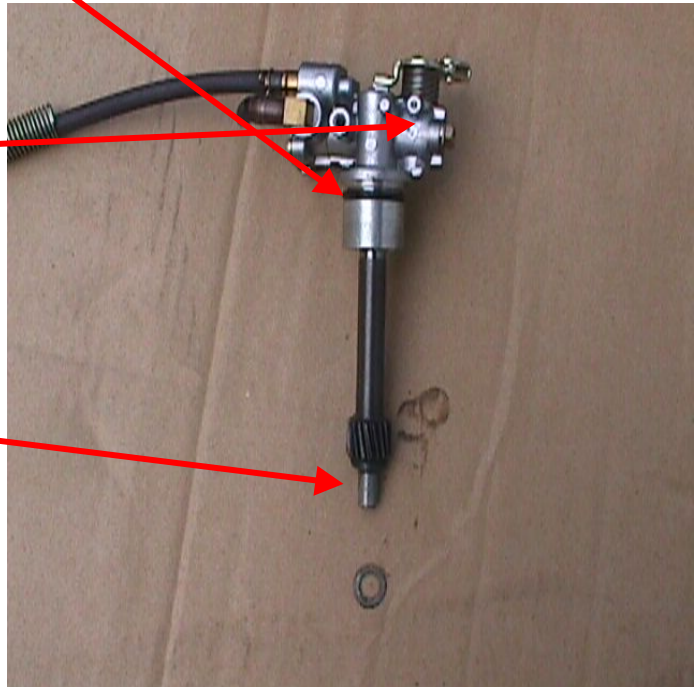

5. Assemble the oil pump.

- a. Assemble the oil pump by reversing above procedure.

O-ring of oil pump should be lubricated by grease or oil, then place on crankcase.  
The contact surface of oil pump and crankcase should be assembled firmly.  
The gears of oil pump should be lubricated by grease.

- b. Be sure oil pump screw is tightened.

After assembling, check the following:

- a. the adjustment of control cables  
b. Is there air in oil pipe.  
c. oil leakage at any location.

6. Releasing air in the oil pump.

- a. If there is air in the oil pipe, it will cause engine lubrication trouble  
b. Releasing air operation means the release of air trapped in the air pipe and oil pump. Please firstly release air from the oil pipe

(a) Fill up specific amount of oil to oil tank.

(b) Place dry cloth under the oil pump.

© Remove oil pipe.

(d) Use injector to fill up the oil in the oil pipe and oil pump body. Be sure the oil pipe and oil pump are full of oil before assembling.

(e) After assembling check if there is still air trapped in the oil pipe.



## (2) Engine Dismantling

### A. Dismantling engine.

1. Take off the luggage compartment.
2. Take off the left and right body covers.
3. Take off the lower mudguard fender.



4. Remove vacuum pipe, fuel pipe, auto choke, cap of spark plug, rear Brake cable carburetor pipe, engine flywheel shelf's nut, starter Motor cable plate and rear damper bolt.

5. Remove the engine.

### B. Installing Engine.

1. To install engine, please reverse the above procedures.

2. Locking torque:

M8: 2.0~3.0kg-m

M10: 3.0~4.0kg-m

M12: 5.0~6.0kg-m

3. After installing, please do the following checking and adjustment:

Checking and adjustment:

- a. Wiring connection.
- b. Throttle cable and oil control cable.
- c. Rear brake adjustment.
- d. Fuel and oil route.

### (3) Drive pulley, starter & clutch

#### A. Troubleshooting:

- a. Engine starts, but vehicle does not move.
  - 1.driving belt worn out
  - 2.driven plate worn out
  - 3.clutch lining worn out
  - 4.driving plate's spring broken
- b. The vehicle stops or trembles when running,
  - 1.clutch lining spring cracked or broken.
- c. Can't reach high speed, no pick-up
  - 1.driving belt worn out.
  - 2.Driving plate spring distortion.
  - 3.Weight roller worn out.
  - 4.Driving plate abnormal.

Note:

No grease and oil allowed to stain on driving belt and driven plate.

#### B. CVT parts measurement data

Item	Standard value(mm)	Limit of use(mm)
Model	50cc	50cc
The inner dia. of Slide driving plate	20.035-20.085	20.123
The outer dia..of boss, movable Driving plate	19.960-19.974	19.911
Belt width	18.0-19.0	17.0
Clutch lining thickness	3	1.5
Clutch outer diameter	117.0~117.2	117.5
Driving plate spring, free length	87.9	82.5
The outer diameter of driven plate sets	33.965~34.025	33.95
The inner diameter of slide Driven plate	34.000~34.025	34.070
The outer diameter of weight Roller set	15.992~16.008	15.50

C. Driving pulley.

1. Take off the 10 screws of left Cover, remove the left cover.



2. Take off the left cover.

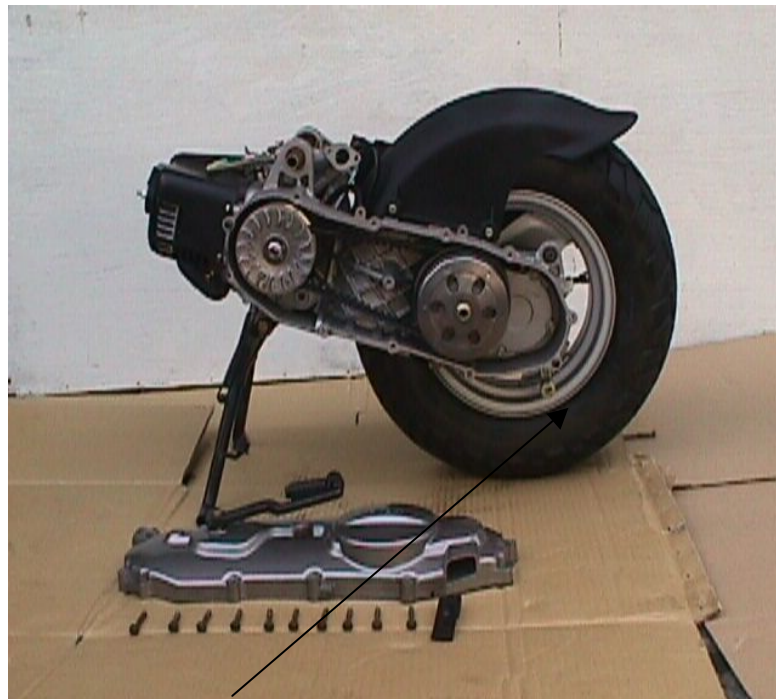



3.Remove the fixing nut of the clutch.

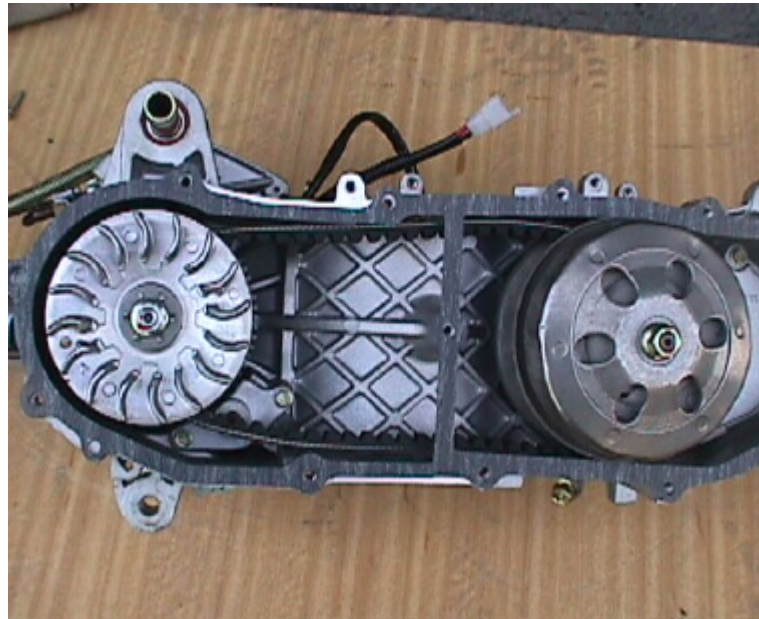

4.Take off the ramp plate.



5.Take off the belt and the rear clutch.

6.Take off the driving plate.

- Take off the driving gear start set.



7.Remove the start idle gear fixing plate.

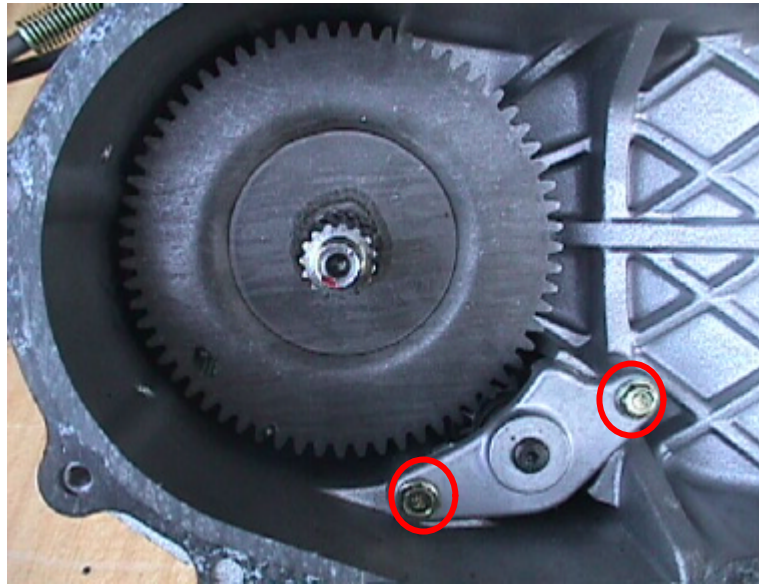

8.Take off the idle gear.

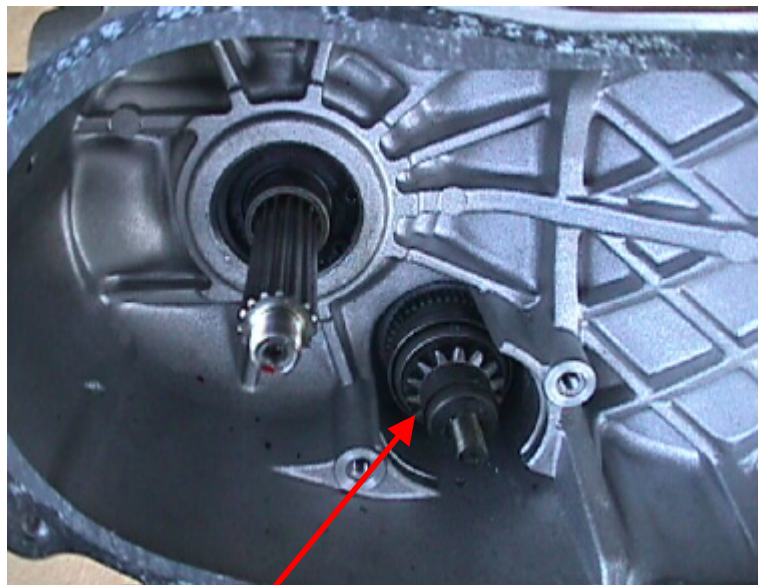

9.To assemble the driving pulley, please reverse above procedure.

Locking torque:

1.Nut of driving pulley:M10: 3.2~4.0kg- m

2.Locking nut of clutch:M10: 3.5~4.0kg- m

10.Checking the driving belt

(1)check whether it is cracked or not or its rubber and fiber are loose or not  
check also if they are extraordinarily worn out.

(2)driving belt width:

limit of use : change it below 17.0mm.

11. Disassemble the slide driving plate set

(1)Remove the bush of slide driving plate

(2)Remove the screw, and disassemble the cover  
of slide driving plate.

(3)Remove RAMP plate.

(4)Remove weight roller.

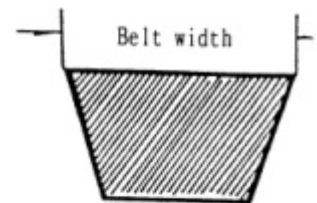

12.Checking list:

(1)Check the wearing condition of the weight roller.

limit of use:change it when below 15.5mm.

(2)Check inner dia of slide driving plate's gasket.

Limit of use:

50cc:Change it when above 20.123 mm

(3)Check the wearing condition for driving pulley surface.

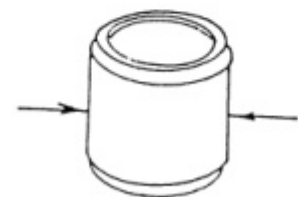

(4)Check the outer diameter of the driving plate's boss.

Check the wearing condition

Limit of use:

change it when below 19.911mm

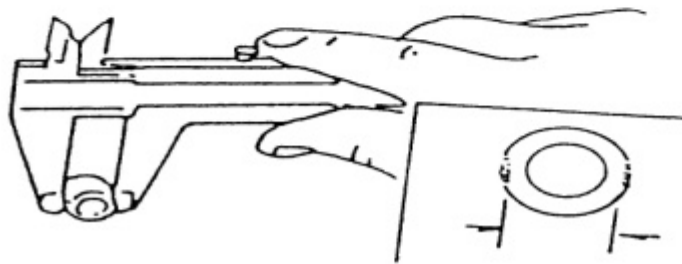
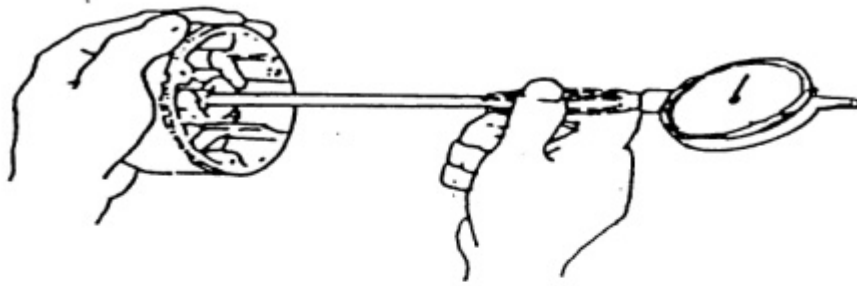

13. Assemble the slide driving plate.

- (1) Clean the inner surface of slide driving plate, then assemble the roller.
- (2) Assemble the ramp plate.
- (3) Please reverse the procedures of disassembling to finish assembling.

#### D. Starter dismantling

1. Dismantle the left crankcase cover
2. Remove the hexagon nut, then remove the starter lever.
3. Remove five screws of isolating plate.
4. Remove the stator spring from the start returning position.
5. Remove the driven gear comp of kick starter.
6. Remove the retaining c-type clip
7. Remove the spindle comp.  
Of kick starter.
8. Checking the starter
  - a. Check the wearing condition of the outer diameter of the spindle comp and the inner diameter of bush and gear.
  - b. Check the wearing condition of the shaft of driven gear comp, gear sets and ratchet.

#### 9. Assembling the starter

To assemble the starter, please follow the opposite procedures of dismantling.

Locking torque: M6:1.0~1.2kg·m

##### Note:

- ① Make sure that one end of the torsion spring is hooked on the groove of driven gear, and another end of the torsion spring is hooked on the pole inside the left crankcase.
- ② Put some grease on shaft and gear sets before assembling.

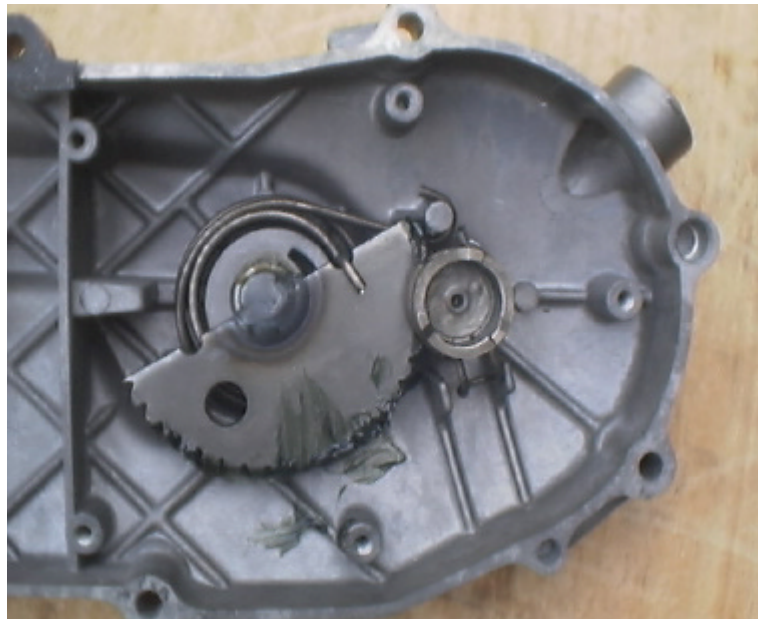

## E. Clutch driven pulley

### 1. Dismantle the clutch

- a. Remove left crankcase cover.
- b. Remove driving plate.
- c. Remove driving belt.
- d. Remove the M10 locking nut, then the clutch.

2. Assembling the clutch: please follow the opposite procedure of dismantling.

Locking torque:  
M10: 3.5~4.0kg·m

### 3. Checking the clutch:

Dismantling the clutch needs the special Tool. please contact your dealers.

- a. Check the clutch driven face.  
Check the clutch cover about its wearing Condition and inner diameter measurement.

Limit of use:  
50cc: Change it when above 117.5mm

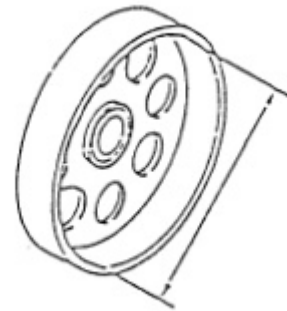

- b. Check the clutch lining wearing condition and measure the lining thickness  
limit of use: change it below 2.5mm.

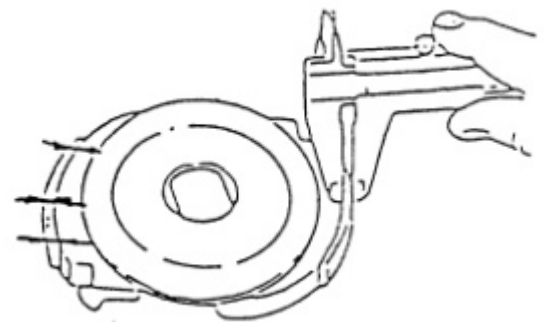

- c. Check driven spring free  
length: standard: 87.9mm  
Limit of use: change it as it  
Is below 82.5mm(50cc)

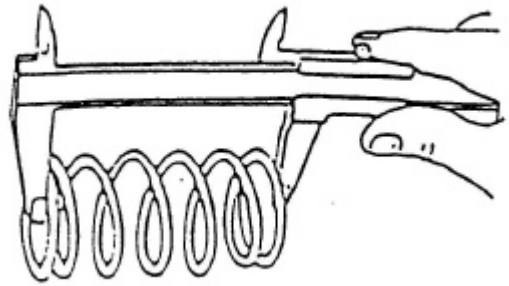

- d. Check wearing condition of  
driving plate set.  
Outer diameter measurement:  
Limit of use: change it as it  
Is above 33.950mm

- e. Check wearing condition of  
slide driven plate.  
Inner diameter measurement:  
Limit of use change it as it  
Is above 34.070mm

- f. Check is there any wearing  
occur to the ditch.

- g. Check wearing condition of  
seal location, if necessary  
change a new one.



## (4)Cylinder and piston:

### A. Troubleshooting.

- a. compression pressure is too low, difficult to start engine and running unsmoothly.
  1. Cylinder head gasket cracked.
  2. Spark plug is not well-locked.
  3. Piston ring worn out or cracked.
  4. Cylinder, piston worn out.
  5. Reed valve is defective.
- b. compression pressure is too high, engine overheating or abnormal noise.
  - 1.piston tip has too much carbon piled up.
- c. Abnormal piston noise
  1. cylinder and piston worn out.
  2. Piston pin hole or piston pin worn out.
  3. Connecting rod small-end or bearing worn out.
- d. Abnormal piston or cylinder noise
  - 1.piston ring worn out or cracked.
  - 2.Cylinder worn out or cracked.

### B. The operation notice:

- 1.clean before operation to avoid particles dropping into engine.
- 2.The connect surface of gasket must be clean.
- 3.Dismantle the cylinder and the cylinder head by screw driver.  
Do not scratch the contact surface.
- 4.Cylinder inner surface and piston outer surface can't be scratched.  
The contact surface should be lubricated by specified oil.

### C. PISTON & CYLINDER DATAS:

Part name/description		Standard Value (mm)	Limit of use (mm)
Cylinder head	Flatness		0.100
cylinder	Bore	39.995~40.015	40.050
Piston/ Piston ring	Clearance b/w Piston ring piston and	Lst ring	0.05~0.06
		2 <sup>nd</sup> ring	0.05~0.06
	Piston outer diameter	39.950~39.970	39.895
	Measuring location of piston outer dia. (12mm from the lower end of skirt)		
	Clearance b/w piston and cylinder	0.045~0.065	0.10
	Piston pin hole inner dia	13.022~13.013	13.045
	Piston pin hole inner diameter	10.002~10.008	10.025
	Piston pin outer diameter	9.994~10.000	9.970
	Clearance between piston and piston pin	0.004~0.018	0.030
	Connecting rod small end inner dia	13.996~14.007	14.025

## D. cylinder head, cylinder, and piston dismantling.

- 1.Remove the engine.
- 2.Screwing out the two M6-bolt of cooling cowl.
- 3.Screwing out the two M6-blot of fan cover.



- 4.Remove the cooling cowl and fan cover.

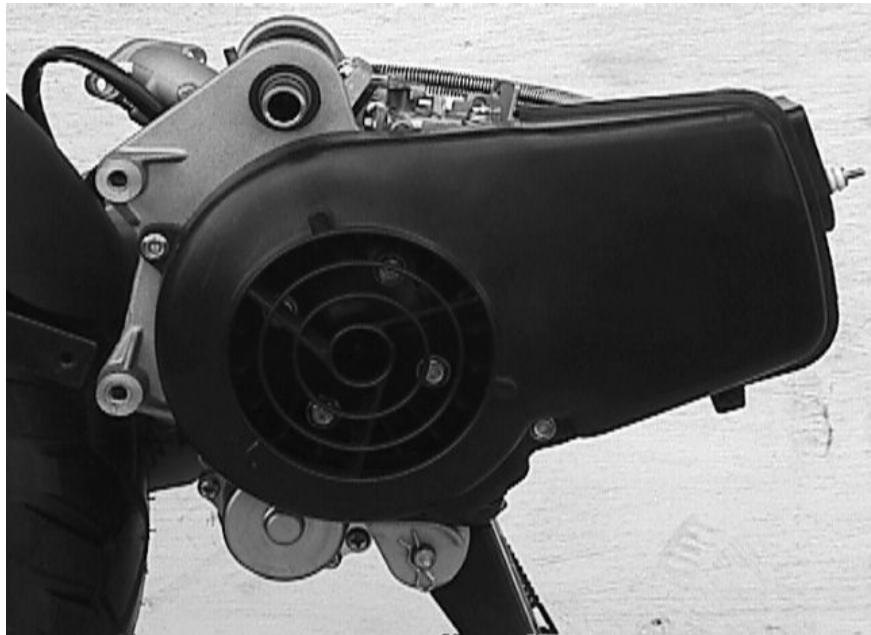

5.Remove the spark plug.

6.Remove the two M6 nuts on the muffler and cylinder.

Also remove the two M8-bolt of crankcase.

7.Remove muffler.



8.Remove the four M7-nut on the cylinder head, then remove the cylinder head and cylinder head gasket.

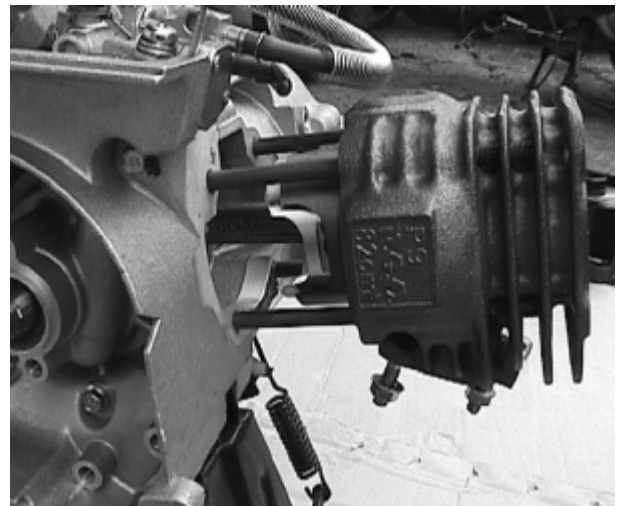
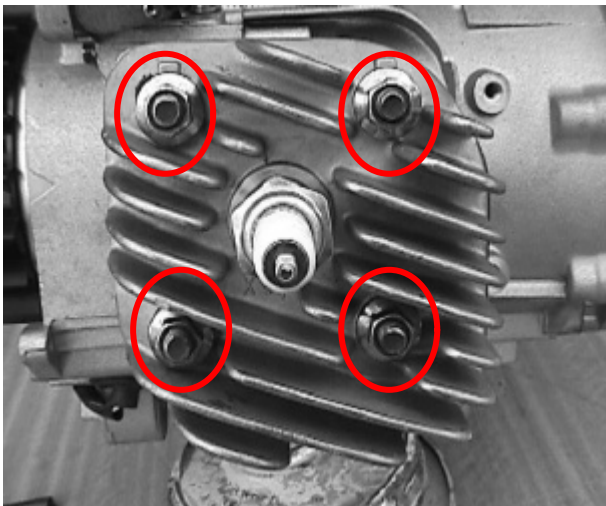

9.Remove the Cylinder and the gasket.

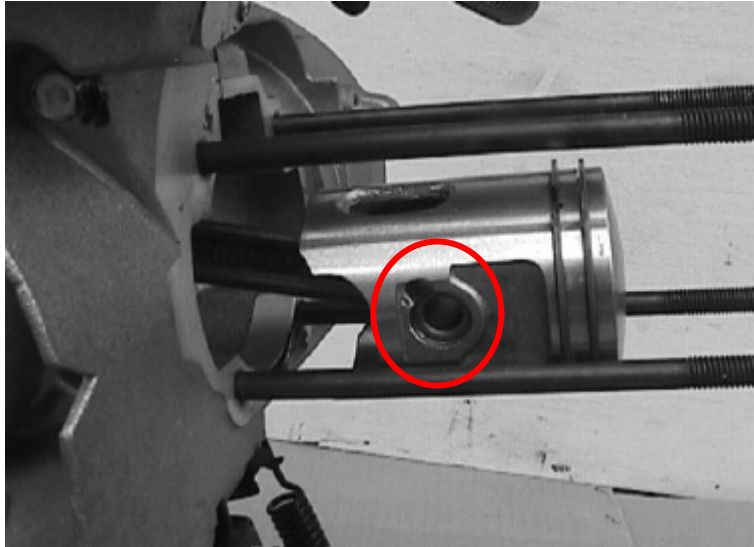

10.Remove the c type clip on the piston and piston pins by the nipper.

- Take off piston.

11.Dismantling of the piston ring Take off the first piston ring then the second ring.

12.When assembling please reverse the procedures of dismantling.

Locking torque: M7:1.0-1.4kg- m M6:1.0-1.2kg- m
---

Opening end of piston ring

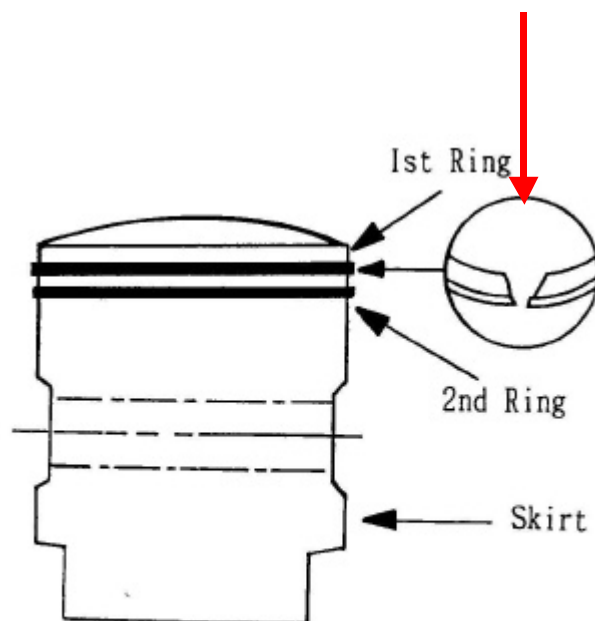

### **E. Check for the flatness of cylinder head & cylinder.**

Check the flatness of contact surface of cylinder head & cylinder.

Limit of use: If it exceeds 0.1mm  
Change a new one.

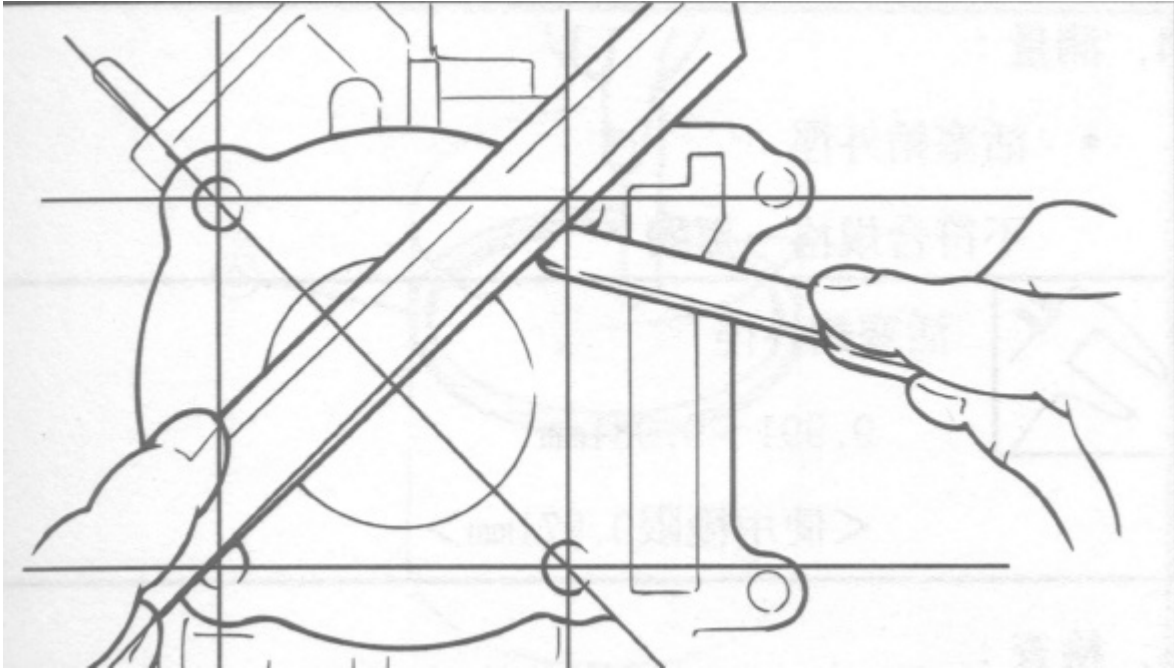

### **F. Combustion chamber cleaning**

- Clean out the carbon piled up in combustion chamber.
  
- Do not scratch the combustion chamber and contact surface of the cylinder during cleaning operation

## G. Check cylinder and piston:

1. Check the wearing and damage condition on the contact surface of the cylinder and piston.
2. Clean out the carbon on the cylinder exhausting port.

Be careful not to scratch the inner surface of cylinder.



### 3. Cylinder bore measurement:

- (1) Measure each point (A)(B)(C) orderly, and in X.Y. axis to find the smallest value.
- (2) Limit of use: 50cc-change it when over 40.050mm

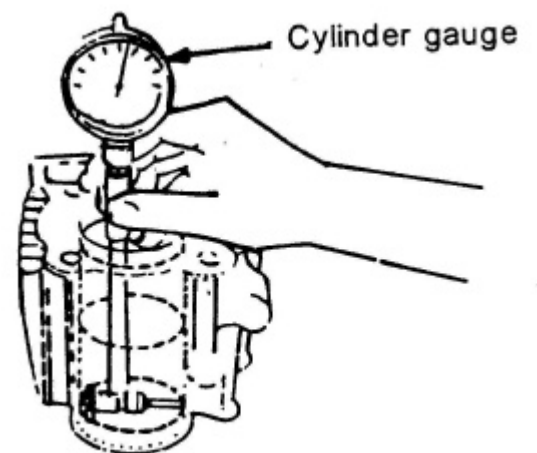
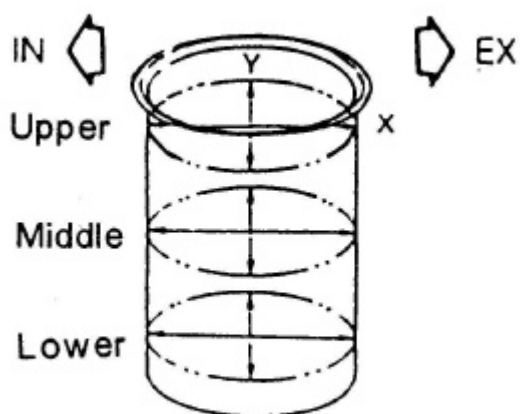



#### 4. Piston outer diameter measurement:

- (1) Measure at the skirt area where is 12 mm from the skirt lower end of skirt.
- (2) Limit of use: 50cc-change if when below 39.895mm



- (3) Calculate the clearance between the cylinder and piston.

Limit of use: change it when over 0.100mm

#### 5. Inner diameter measurement of the piston pin hole

Limit of use: change it when over 14.032mm

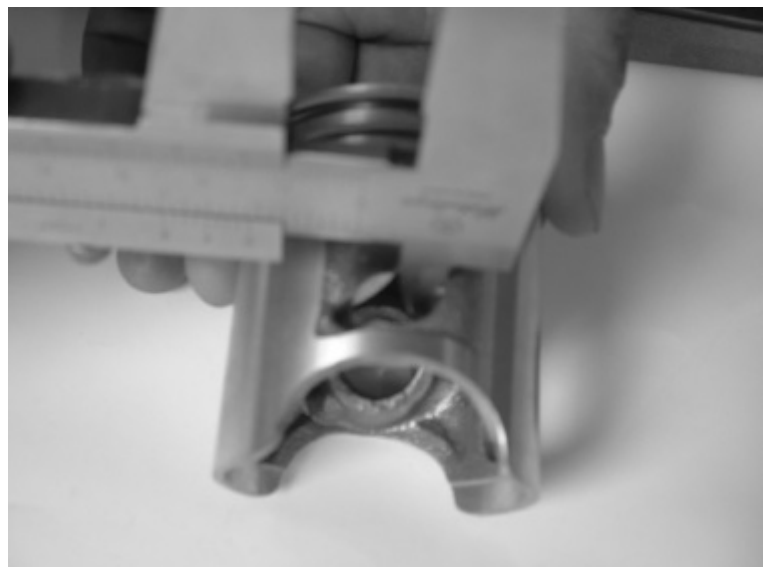

## 6. Outer diameter measurement of the piston pin

limit of use: change it when under 9.970mm (50cc)

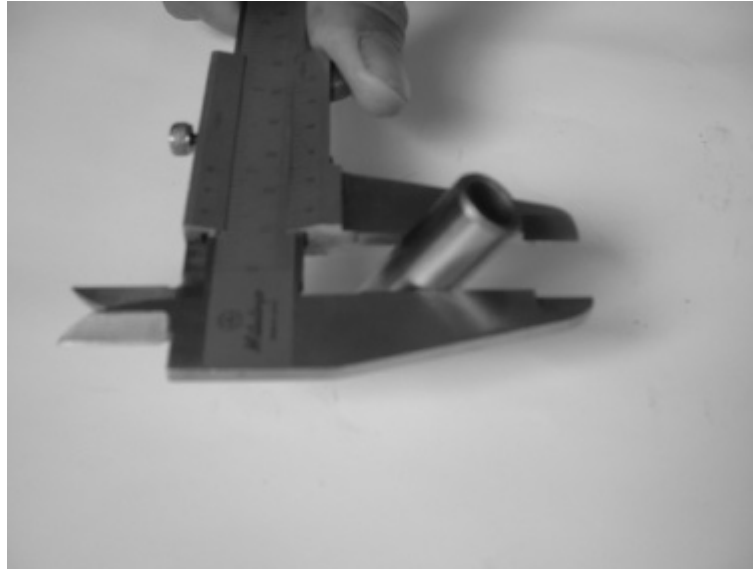

## 7. Check piston ring:

Measure piston ring gap:

Limit of use: change new ones when the first ring and second ring are over 0.4mm

Push the piston ring into the cylinder  
By piston, the measure the gap

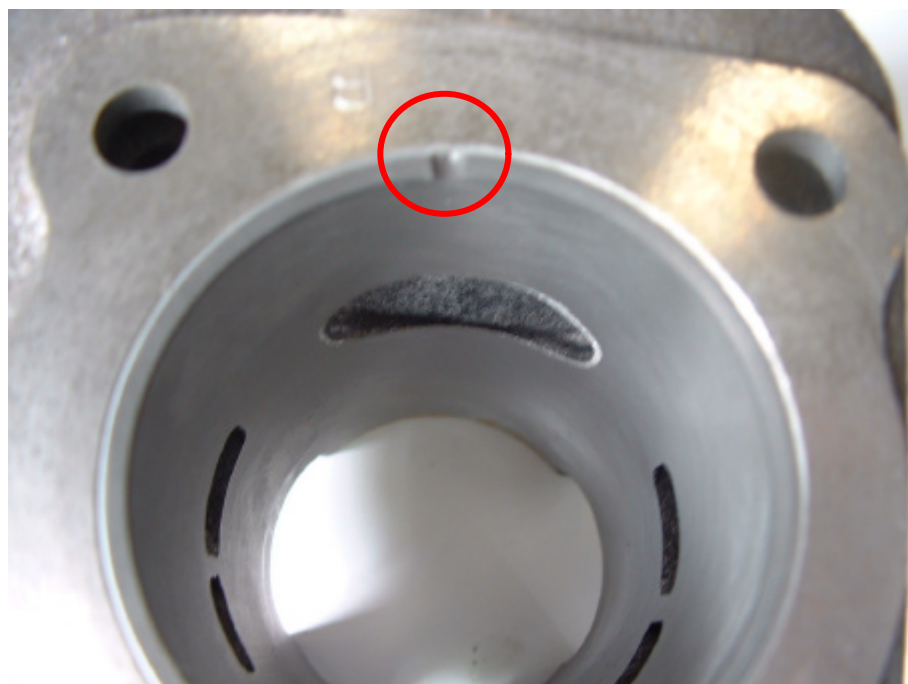

## 8. Check connecting rod small end

- (1) Install piston pin, bearing onto the connecting rod small end, then check the looseness of the piston pin.
- (2) Measure the inner diameter of the connecting rod small end.

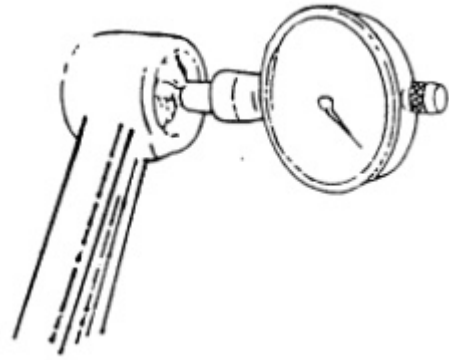

Limit of use: replace a new one when over 14.025mm .( 50cc)

## H. Installing cylinder and piston

1. Place the piston ring into the second ring ditch first, then install the piston ring into the first ditch.
- 2
  - a. Piston ring should be installed into piston ring ditch by even force
  - b. After assembling, be sure that the piston ring sliding surface is at the same height as the piston outer surface.
  - c. If the piston ring can not fit into the ditch, please clean up the carbon in the piston ring ditch or piston ring itself.
3.
  - a. Piston ring must be installed in the correct location.
  - b. After installing the piston ring, it should be able to rotate freely.
  - c. If it is necessary to change the new piston ring, it must change the whole set.
4.
  - a. The location of the piston ring gap and the lock pin must be in opposite side.
  - b. The mark "→" on the piston tip must be pointing to the exhaust port.
  - c. Lubricate the piston pin before installation.
5. Please follow the opposite procedure of dismantling to install cylinder and cylinder head.

## (5)A.C. Generator, Flywheel

### A. Dismantling AC generator

1. Remove fan cowl.
2. Remove the M6 screws(4)
3. Remove Screws of flywheel magneto
4. Remove the AC flywheel magneto by special tool.

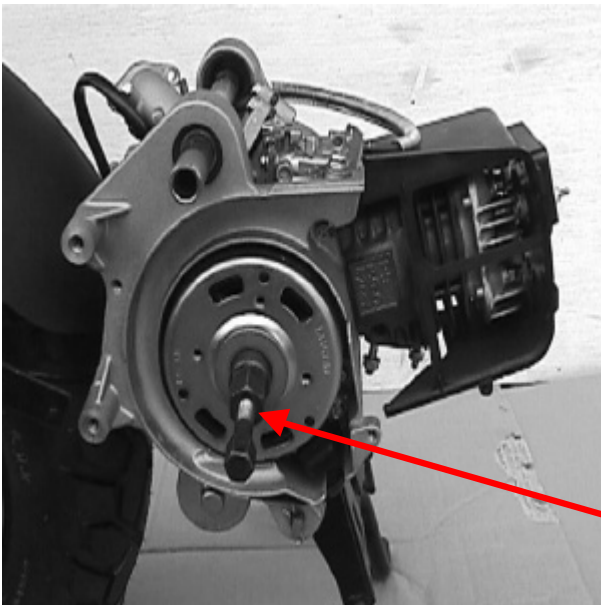
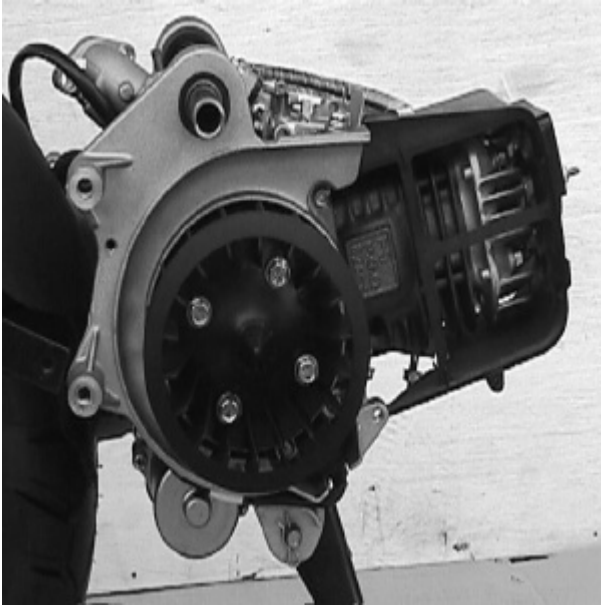

5.Remove the flywheel.

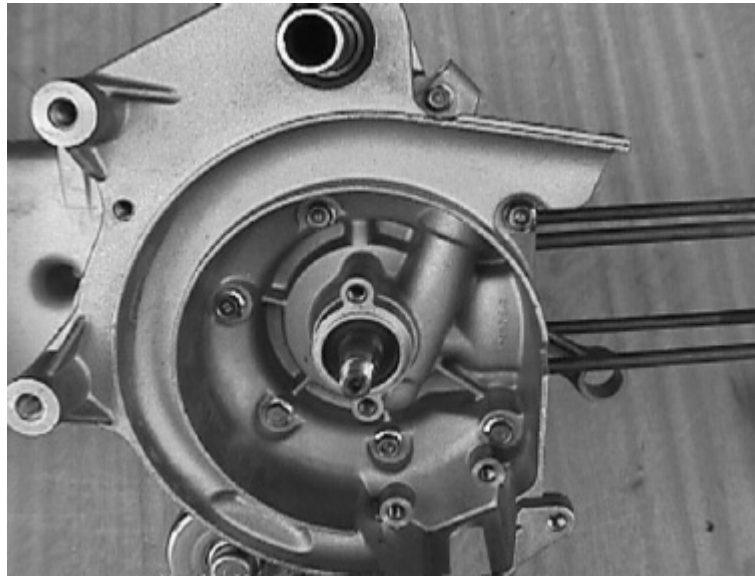

6.Remove the electric plug of AC Flywheel magneto.  
Take out the magneto.

## **B. Install AC generator**

To install, please reverse the dismantling procedures.

Locking torque: M6: 1.0~1.2kg-m M10: 3.2~4.0kg-m
--

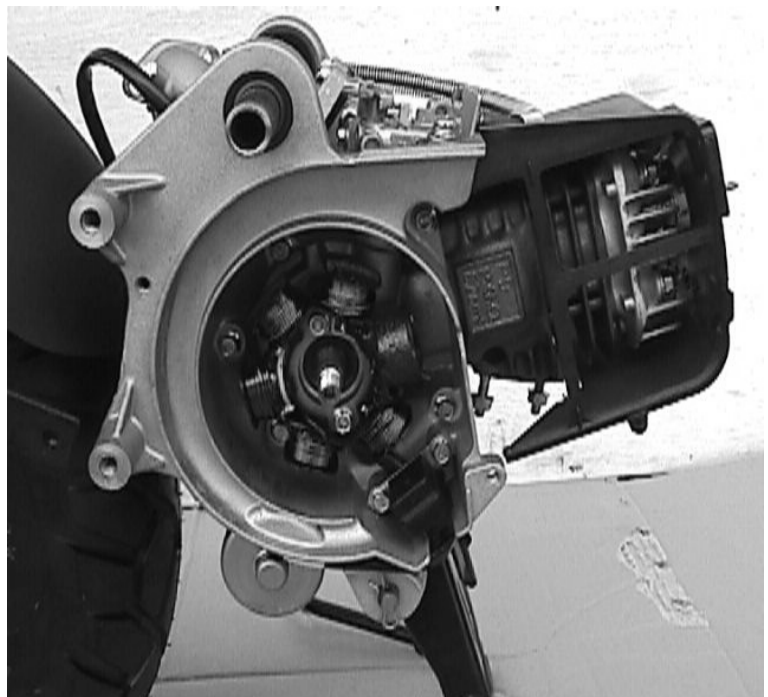

## (6) Final Transmission Mechanism

### A. Trouble shooting

- Engine can be started, but vehicle doesn't move.
  1. Gear worn-out or cracked.
  2. Gear burnt out.
- Noise occurs when running.
  1. Gear worn out, burnt or gear surface damaged.
  2. Bearing worn out or loosen.
- Oil leakage
  1. Too much oil.
  2. Seal worn out or damaged.

### B. Disassemble the final transmission mechanism.

1. Remove the rear wheel.



2. Drain off the oil in the gear box.

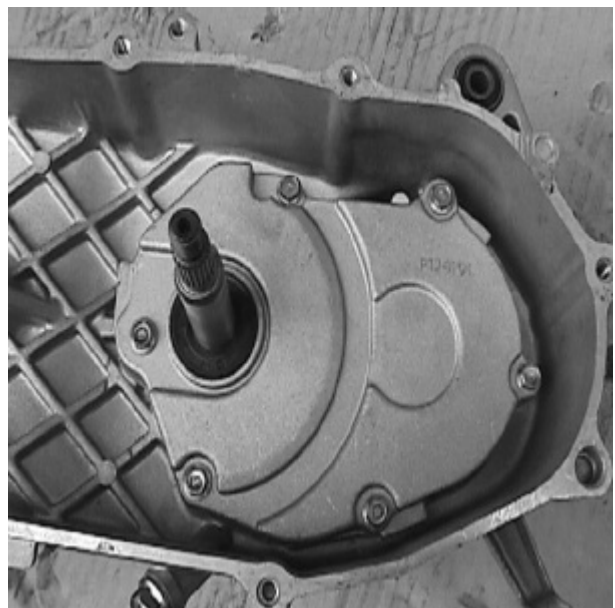



3.Remove the 6 bolt in gear box cover

4.Take off the gear box.

5.Take out the final reduction gear and idle gear shaft.

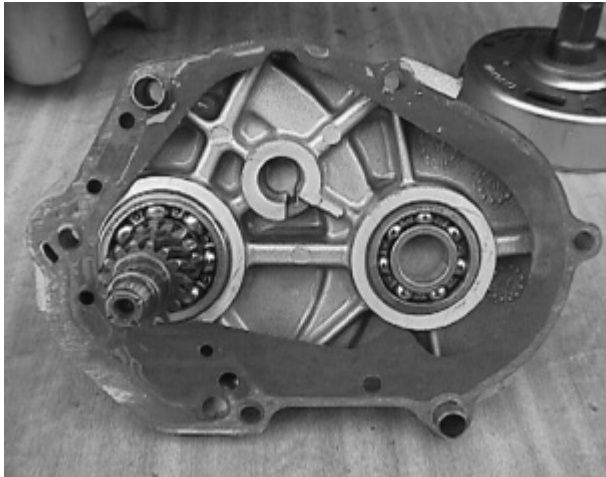

6.Clean up the gear box

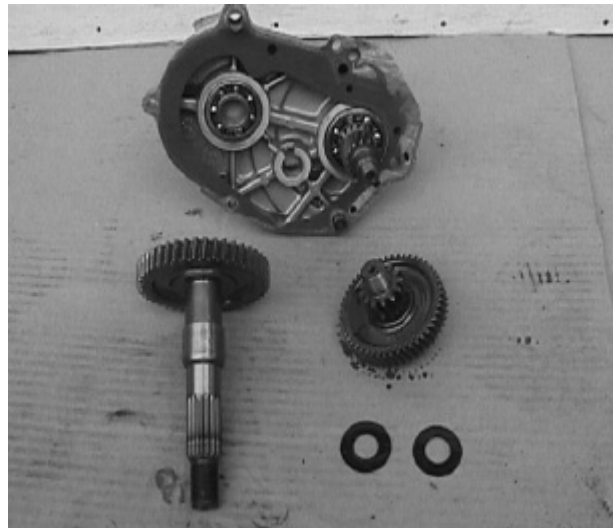

C. Check the final transmission mechanism

1. Check the wearing condition of the driving shaft and gears.

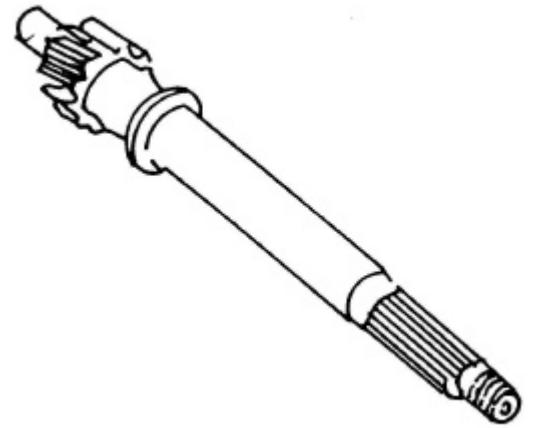

2. Check the wearing condition of the idle gear shaft and idle gears.

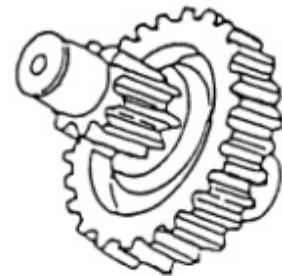

3. Check the wearing condition of the final reduction gear.

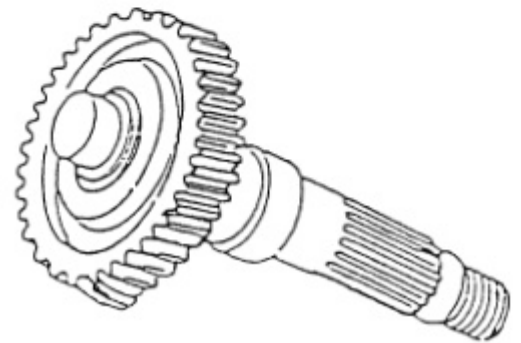

4. Check the wearing condition of the oil seal and bearing.

**D. Assemble the final transmission mechanism: please follow the opposite procedures Of disassembling. After locking the drain bolt, refill 90c.c of gear oil, SAE 85W/140.**

Locking torque: M6: 1.0~1.2 kg-m M10: 3.5~4.0 kg-m Drain bolt: M8: 1.8 kg-m
---

**(7)Crankcase, Crankshaft:**

A. Disassembling diagram

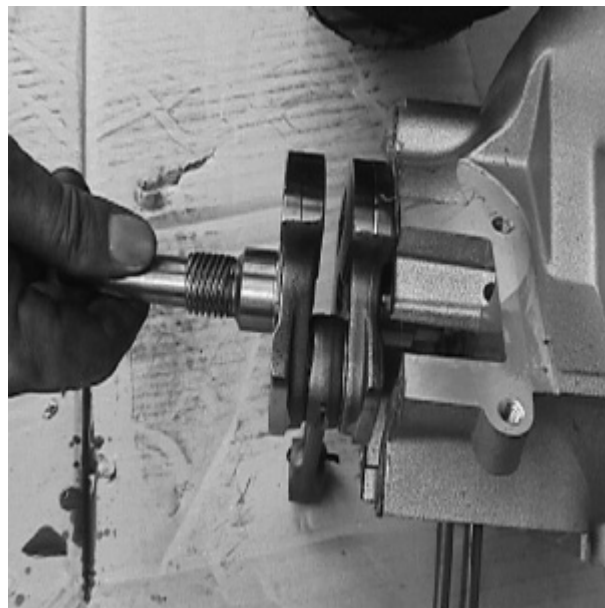
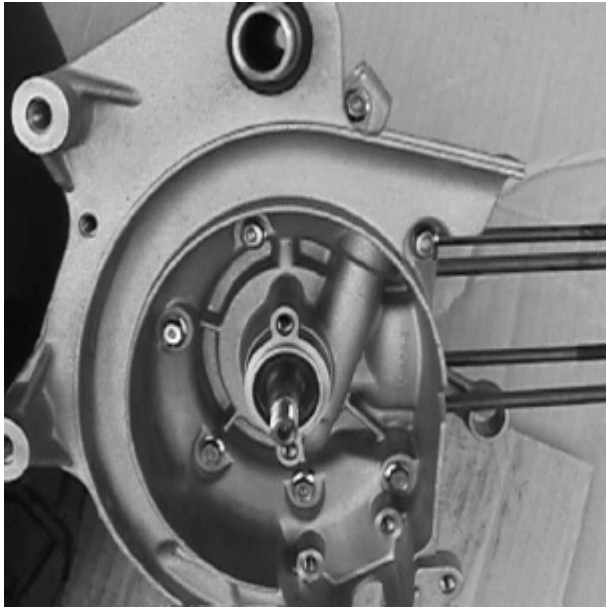

## B. Troubleshooting.

Engine noise:

- 1.The bearing of final transmission mechanism is loose.
- 2.Crank pin bearing is loose.
- 3.The bearing of gear box is loose.

## C. Data

Measuring Item	Standard value	Limit of use.(mm)
Clearance of connecting rod big end (Parallel direction to rod)	0.20-0.50	0.71(50cc)
Clearance of connecting rod big end (Perpendicular direction to rod)	-	0.04
Swingness of the crank shaft neck	0.03	0.10

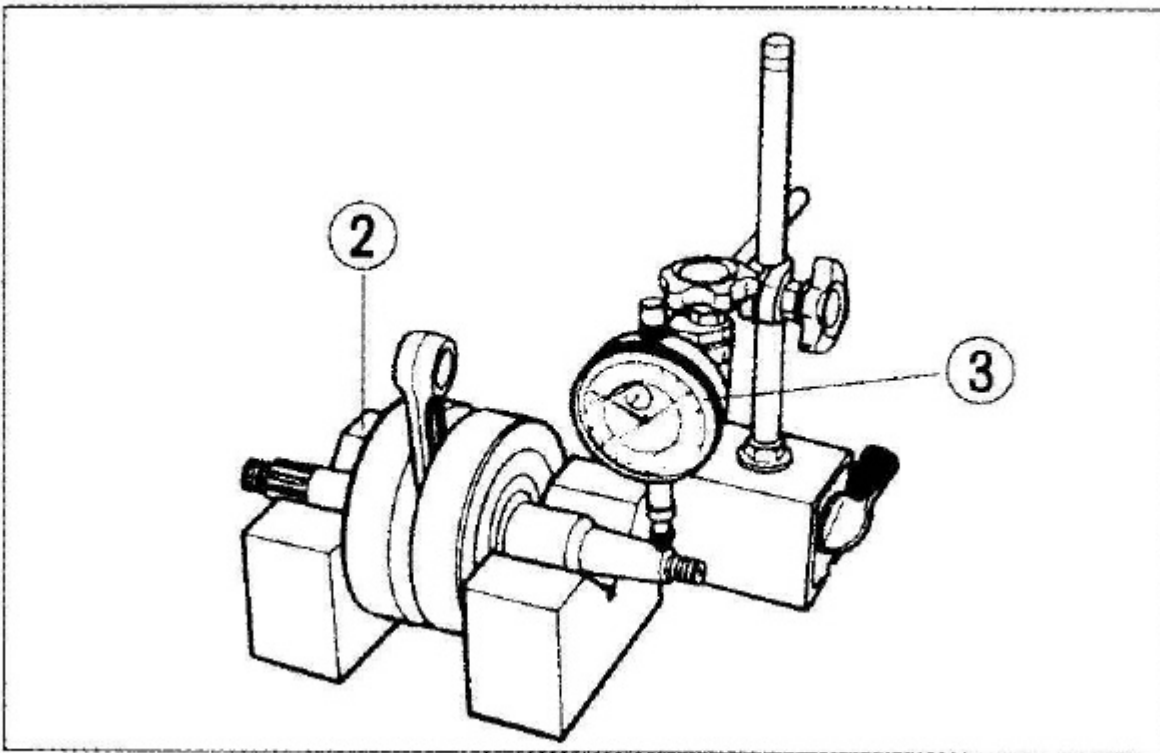

D. Dismantle the crankcase and crankshaft please follow the following procedures:

1.Remove the engine.



2.Remove the left crank case, the driving pulley (driving plate) clutch and belt.

3.Remove the air cleaner.

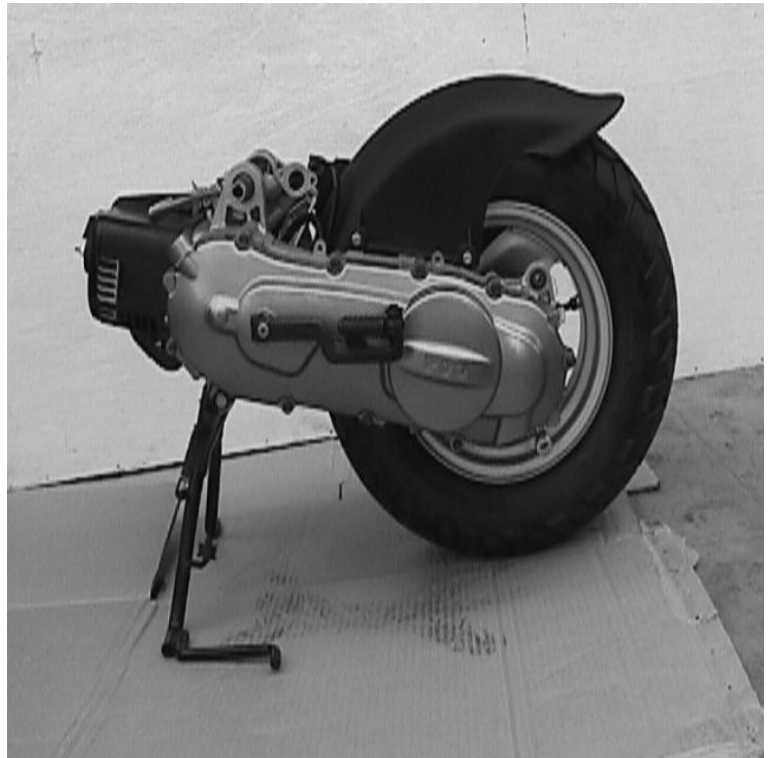

4.Remove the carburetor.

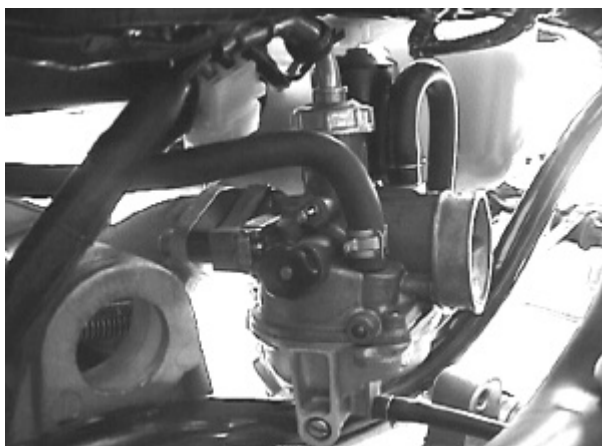

5.Remove the intake manifold and reed valve.

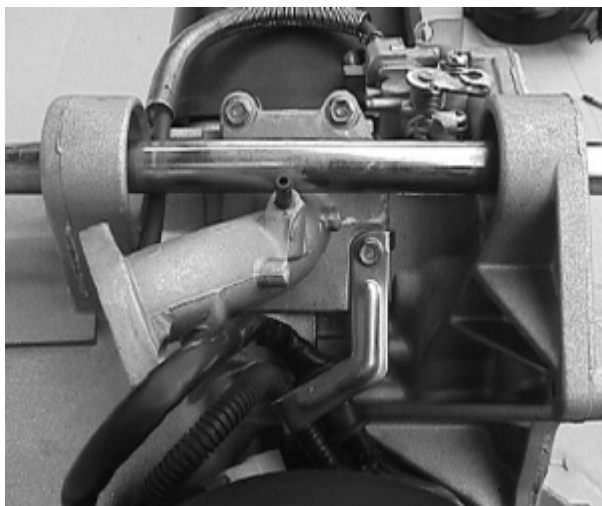

6.Remove the oil pump, fan cowl and fan itself.

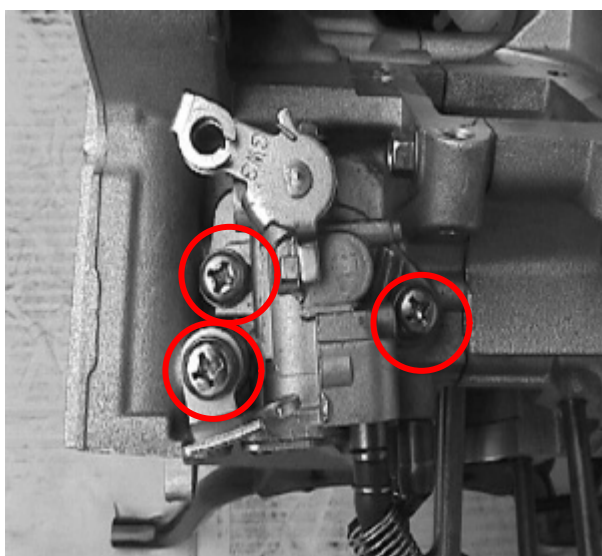

7.Remove the AC flywheel magneto.



8.Dismantle the right and left crankcase.  
There are all together 7 bolts.

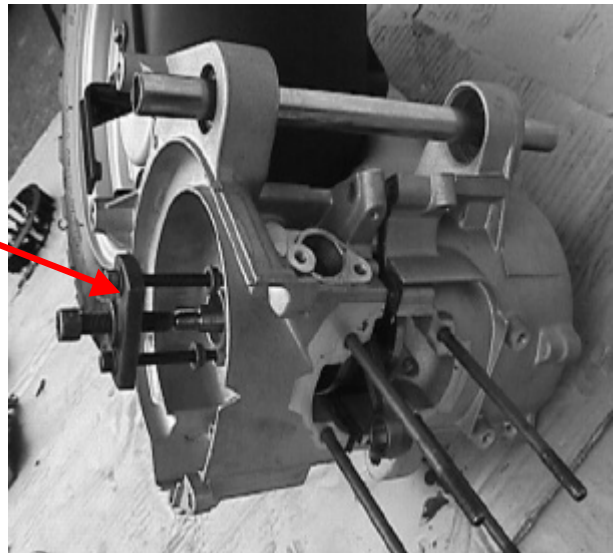

9.Remove center stand, left and right crankcase and take out the crankshaft.

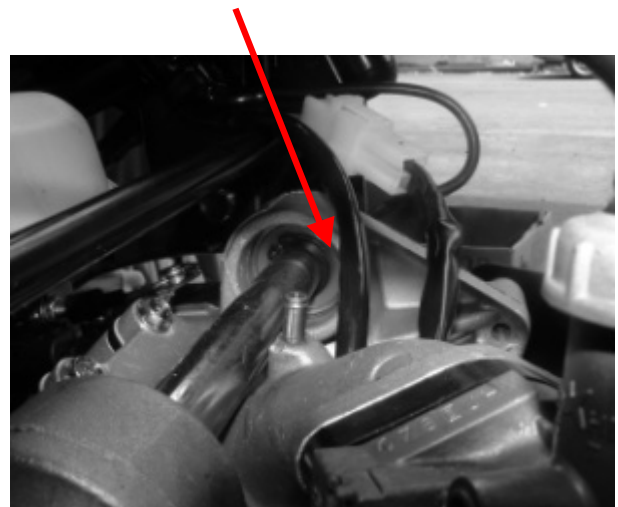
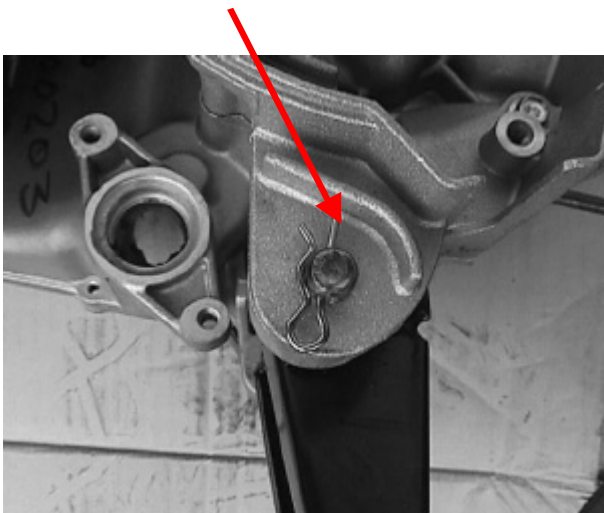



E. Check the crankshaft:

1. measure the clearance between crank shaft and co-rod big end. (Parallel direction to rod)

Limit of use: Replace a new when above 0.71mm

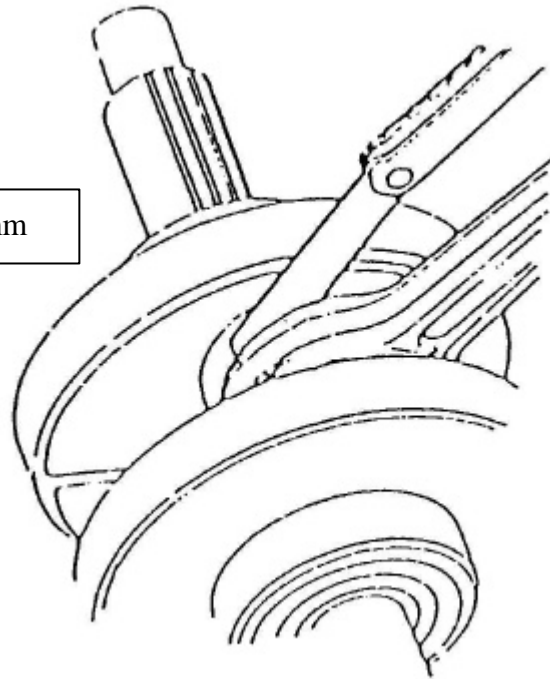

2. check the looseness on X.Y. axis of the connecting rod big end (Perpendicular directions to rod)

Limit of use: Replace a new one when above 0.04mm

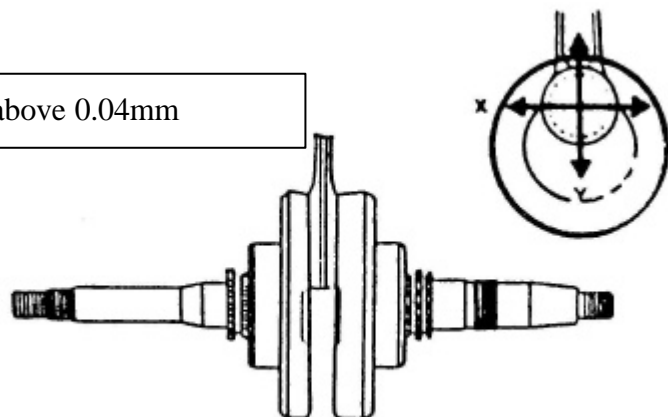

3. measure the swingness of crank shaft neck.

Limit of use	
A	B
Change it when Above 0.1mm	Change it when Above 0.1mm

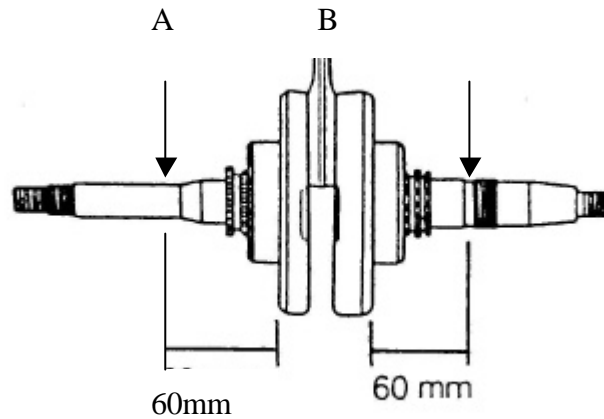

4. check the slackness of crankshaft bearing,  
if it is slack, change a new one.

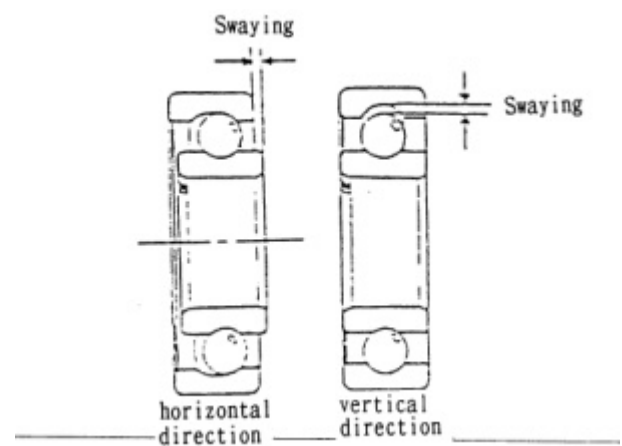

F. Assemble the crankcase.

1. To assemble the crankcase, please reverse the procedures of disassembly.
2. The locking torque value for bolts and nuts are all described in the previous chapters. Please refer.

## (8)Carburetor, Reed Valve

A: Carburetor dismantling diagram

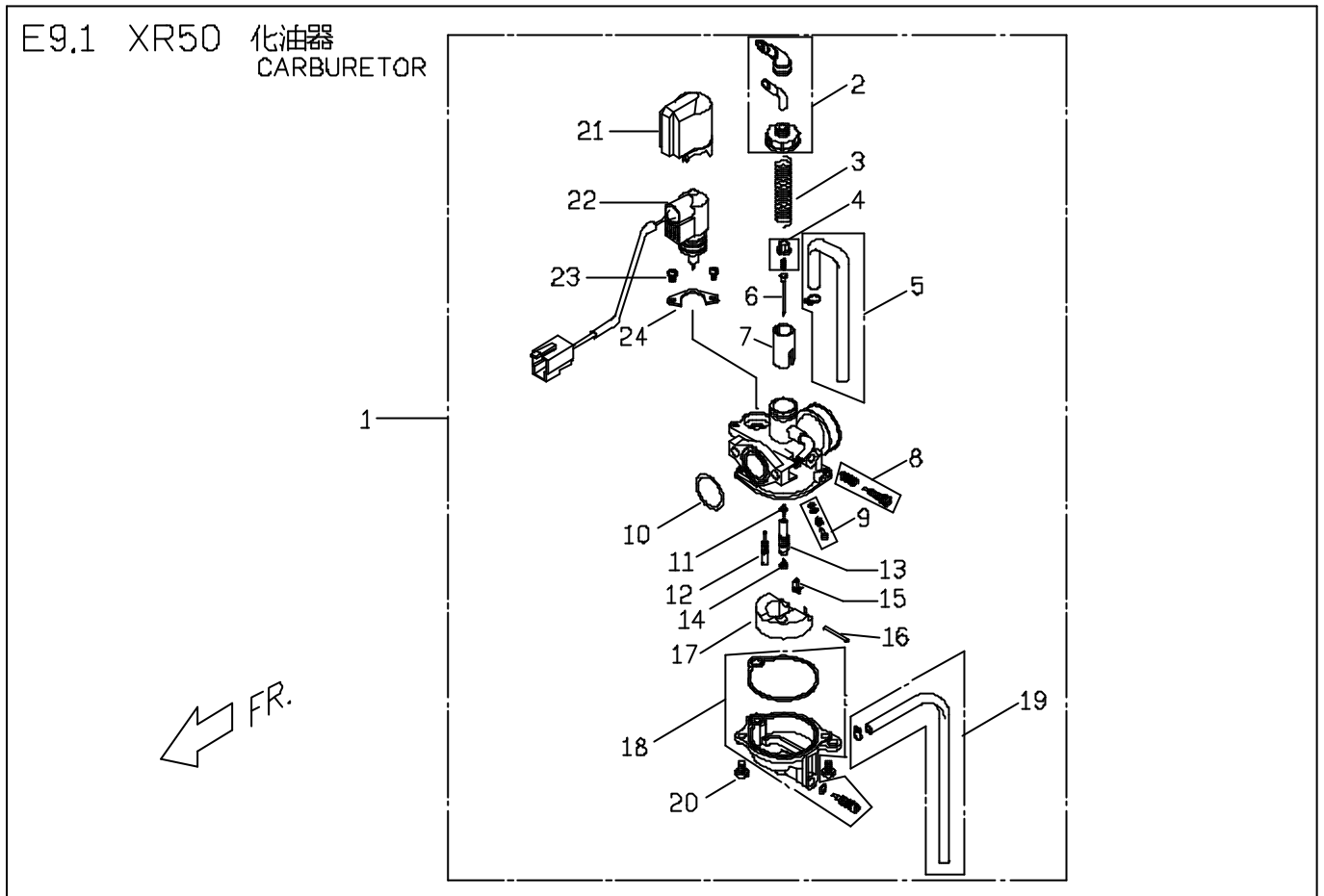

01	CARBURETOR ASSY.	13	HOLDER, NEEDLE JET
02	TOP SET	14	MAIN JET
03	SPG., COMP.	15	FLOAT VALVE SET
04	PLATE SET	16	PIN, ARM
05	TUBE SET	17	FLOAT SET
06	JET NEEDLE	18	FLOAT CHAMBER SET
07	THROTTLE VALVE	19	TUBE SET
08	SCREW SET	20	"SCREW, WASHER"
09	SCREW SET (A.S)	21	CAP HOLDER
10	O RING	22	AUTO BYSTARTER SET
11	NEEDLE JET	23	SCREW, WASHER
12	SLOW JET	24	PLATE SET

B. Troubleshooting:

- a. Engine can not be started.
  - 1.No fuel in the fuel tank.
  - 2.Fuel pipe is blocked.
  - 3.There is too much fuel in the cylinder.
  - 4.Air cleaner is blocked.
  
- b. Engine idling(RPM) unsteady, running not smoothly
  - 1.Improper adjustment of the carburetor idling.
  - 2.Ignition disorder.
  - 3.Compression pressure is too low.
  - 4.Air mixture is too thick.
  - 5.Air mixture is too lean.
  - 6.Air cleaner is blocked.
  - 7.Air injection is not in good function.
  - 8.Fuel is dirty.
  
- c. Air mixture is too lean.
  - 1.Carburetor main jet is blocked
  - 2.The ventilation hole of the fuel tank cover is blocked.
  - 3.Fuel filter is blocked.
  - 4.Fuel pipe bended, squeezed or blocked.
  - 5.Float valve is abnormal.
  - 6.Fuel level is too low.
  - 7.Air pipe is blocked.
  
- d. Air mixture is too thick
  - 1.Float valve is abnormal.
  - 2.Fuel level is too high.
  - 3.Air jet is blocked.

### C. Dismantling carburetor

1. Remove the luggage box.
2. Loosen the hose clamp between the carburetor and the air cleaner.  
Then remove the air cleaner.
3. Unscrew the fuel draining screw of the carburetor. Drain off the fuel inside the carburetor.
4. Remove the fuel pipe and the vacuum pipe on the carburetor.
5. Remove the oil pipe on the carburetor.
6. Remove the bolts on the intake manifold and carburetor.



### D. Dismantling float, nozzle

**Note:**

The auto choke has been properly adjusted already. Please do not adjust it further.  
When there is blockage in the carburetor, please clean it by air compressor.



## E. Reed valve

### 1. Dismantling reed valve.

- (1) Take off the luggage box
- (2) Remove the air cleaner
- (3) Remove the carburetor.
- (4) Unscrew the locking screw of the intake manifold.

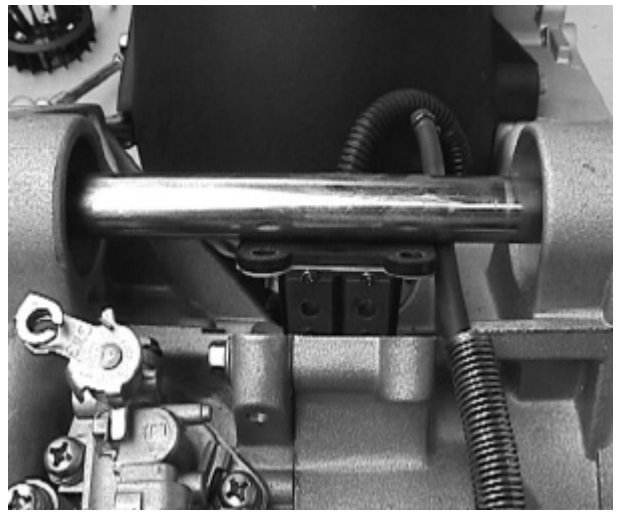
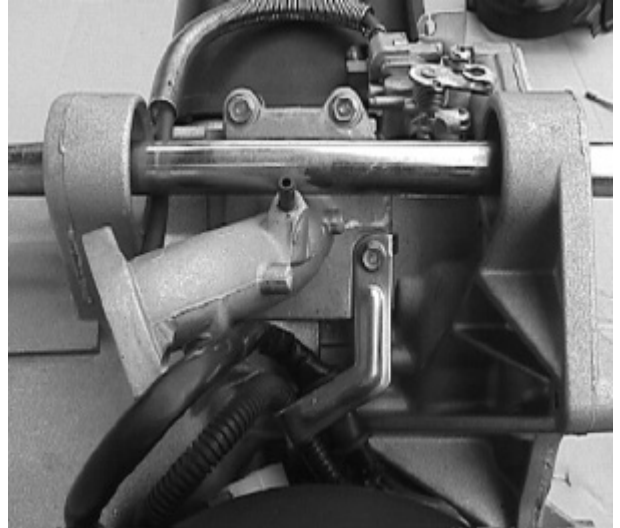

- (5) Remove the intake manifold.

- (6) Remove the reed valve.

### 2. checking for the reed valve.

- change a new one when the reed valve is worn out or distorted.
- change a new one too when the base of the reed valve is cracked, injured or distorted.