

WORKSHOP MANUAL



JETFORCE

CONTENTS

CONTENTS

CONTENTS	2
CHARACTERISTICS	5
Engine.....	5
Capacities	5
Chassis markings.....	5
Engine markings.....	5
Frame.....	6
Dimensions and weight	6
Tyres.....	6
SERVICE SCHEDULE AND COMMISSIONING	7
Check.....	7
Change.....	7
Check and lubricate	7
Reading the ECU fault codes	7
Test machine.....	7
SPECIAL IMPORTANT POINTS	8
Oil and fuel.....	8
Starting up after overhauling the engine	8
Electricity	8
Special features.....	8
TIGHTENING TORQUES	9
Body panels	9
Frame.....	9
Standard.....	9
SPECIAL TOOLS	10
INSTRUMENT CLUSTER	11
Instrument cluster description	11
Description of the multi-function display	12
MULTI-FUNCTION DISPLAY FUNCTIONS AND SETTINGS	12
Changing from the total distance display to the daily display	12
Changing the distance unit	13
Setting the clock.....	13
Maintenance function	14
Fuel gauge self-diagnostic.....	14
CONTROL CABLE AND HARNESS ROUTINGS	15
ABS/PBS panel	15
Conventional braking panel.....	15
Right-hand side 50 cc	16
Left-hand side 125 cc	17
Rear right.....	18
Rear centre.....	18
LOCATION OF COMPONENTS	19
50 cc	19
125 cc	20
BODY	21
Location of body components (50 and 125 cc).....	21
Body component sequence of disassembly (50 and 125 cc).....	21
Removal of front lower legshields (50 and 125 cc) Procedure 1	22
Removal of the headlight and sidelight assemblies (50 and 125 cc).....	22
Method for fitting the lower legshield bracket (50 and 125 cc).....	22

CONTENTS

Removal of the storage compartment (50 and 125 cc) Procedure 2	23
Removal of the shield)(50 and 125 cc) Procedure 3	23
Removal of the rear cover assembly and mudflap (50 and 125 cc) Procedure 4	25
Removal of the rear light / storage compartment trim (50 and 125 cc)	25
FRAME	26
Removal of the rear frame (50 cc).....	26
Removal of the frame (50 cc).....	27
MISCELLANEOUS OPERATIONS	29
Removal of the oil tank (50 cc) or oil separator (125 cc), the saddle lock (50 and 125 cc).....	29
To remove the oil filter (50 cc)	29
To remove the header tank (50 and 125 cc)	29
Removal of the radiator / radiator bracket (50 and 125 cc).....	30
Removal of the fuel gauge (50 cc)	31
Removal of the strainer (50 cc)	32
Removal of the fuel tank filler ring (50 and 125 cc)	33
Removal of the fuel tank (50 cc)	33
Removal of the central shock absorber / from the swingarm (50 and 125 cc).....	34
Removal of the radiator deflector (50 cc)	35
Removal of the braking limiter (50 cc)	35
Removal of the saddle strut (50 and 125 cc)	35
WORKING ON THE ENGINE WITHOUT REMOVING THE ENGINE (50 cc)	36
Removal of the inlet coupling and valves	36
To remove the cylinder head Procedure 5	37
Removal of the cylinder / piston	37
Removal of the temperature sensor	38
Removal of the air compressor.....	38
SPECIAL WORK AND PROCEDURES WITHOUT REMOVING THE ENGINE.....	39
Procedure for reducing the fuel circuit pressure Procedure 6 (50 cc)	39
Procedure for bleeding the fuel circuit Procedure 7 (50 and 125 cc)	39
Removal of the injection manifold (50 cc).....	40
Removal of the air injector (50 cc).....	40
Removal of the thermostat (50 cc)	41
Removal of the ECU (50 and 125 cc)	42
Removal of the throttle unit (50 cc)	42
Removal of the oil pump (50 cc).....	43
Removal of the fuel gauge (50 cc)	43
ELECTRICITY	44
Removal of the instrument cluster (50 and 125 cc).....	44
Removal of the voltage regulator and saddle actuator (50 and 125 cc)	44
Removal of the battery cover, battery, fuses (50 and 125 cc)	44
Removal of the starter motor and/or lighting relay (50 and 125 cc) and/or the fuel pump and/or ABS/PBS system relay (125 cc).....	45
Removal of the high tension coil (50 and 125 cc).....	45
Removal of the horn, immobiliser module (50 and 125 cc).....	45
Removal of the transponder antenna (50 and 125 cc)	46
Removal of the starter motor (50 cc).....	46
ENGINE REMOVAL	47
Removal of the 50 cc engine	47
125 cc SPECIFIC MISCELLANEOUS WORK	48
Removal of the idle valve.....	48
Removal of the thermostat	48

CONTENTS

Removal of the engine temperature sensor	48
Removal of the fuel injector	49
Removal of the oil pressure switch	49
Removal of the throttle unit.....	49
Removal of the fuel pump / of the fuel gauge.....	51
Removal of the starter motor.....	52
Removal of the rear brake pads or caliper.....	53
Removal of the suspension arm.....	53
Removal of the engine mounting twin linkrod.....	54
Method of fitting the engine mounting twin linkrod.....	55
Removal of the motor-driven fan heat switch	56
Removal of the motor-driven fan	56
125 cc SPECIFIC WORK REQUIRING ENGINE REMOVAL	57
Removal of the power unit Procedure 8	57
Removal of the engine Procedure 9	58
Removal of the rocker cover, setting the rockers, removal of the camshaft, removal of the rockers	58
Removal of the cylinder head, removal of the cylinder and/or piston, removal of the cylinder head or base gasket, removal of the timing chain, setting the timing	58
Removal of the connecting rod and/or LH bearing and/or changing the casings	58

CHARACTERISTICS

CHARACTERISTICS

Engine

	50 cc	125 cc
Type	Single cylinder 2-stroke direct injection	Single cylinder 4-stroke indirect injection
Cooling	Liquid	
Bore x stroke	39.9 x 39.8 mm	57 x 48.9 mm
Cubic capacity	49.9 cc	124.8 cc
Max. power output	3.6 kW at 7500 rpm	9.2 kW at 8750 rpm
Max. torque at	6500 rpm	7250 rpm
Fuel system	Direct electronic injection (TSDI)	Indirect electronic injection (EFI)
Lubrication	Electric oil pump	Trochoidal pump
Transmission	2 variable pulleys and Vee belt	
Clutch	Centrifugal automatic	
Spark plug	NGK CPR8E	NGK CR7EB
Exhaust	Catalytic	Non-catalytic

Capacities

Fuel tank	8 litres 95 or 98 lead-free	
Oil tank	1.2 litres semi-synthetic (API TC)	
Engine oil		1.25 litres SAE 10W40
Relay box oil	0.12 litres SAE 80W90 Life lubricated	
Coolant*	1.3 l	1.6 l
Fork	125 cc by tube Esso Unavis 46 or Agip H Lift 46	190 cc by tube Esso Unavis 46 or Agip H Lift 46

* Peugeot coolant part number 754614

Chassis markings

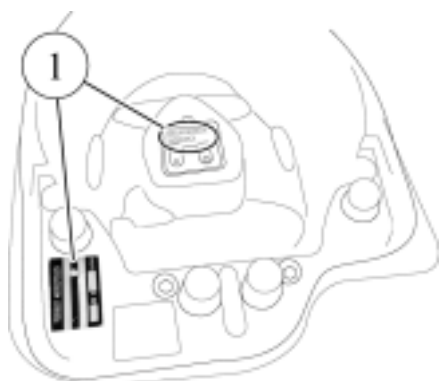

1 – VIN number and manufacturer's plate

Engine markings

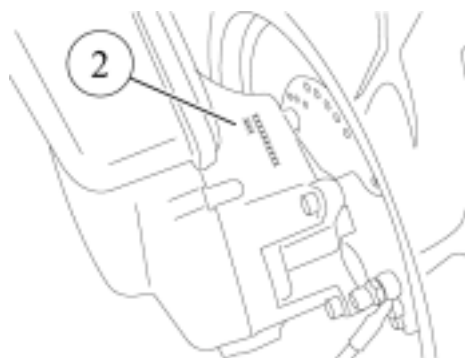

2 – Engine number

CHARACTERISTICS

Frame

	50 cc	125 cc
Frame	Direct Perimetric Frame	
Front suspension	Ø 32 mm telescopic fork	Ø 36 mm telescopic fork
Travel	85 mm	95 mm
Rear suspension	Central shock absorber	
Travel	95 mm	90 mm

Dimensions and weight

Overall length	1914 mm	1918 mm
Width at handlebar	740 mm	
Height with rear view mirror	1260 mm	1279 mm
Wheelbase	1314 mm	1369 mm
Ground clearance	137 mm	112 mm
Saddle height:	820 mm	845 mm
Unladen weight	115 kg	149 kg

Tyres

Front wheel	13-inch alloy	
Front tyre	130/60 - 13	
Front tyre pressure	2 bar	2 bar
Rear wheel	13-inch alloy	
Rear tyre	130/60 - 13	140/60 - 13
Rear tyre pressure	2.2 bar	2.2 bar

SERVICE SCHEDULE AND COMMISSIONING

SERVICE SCHEDULE AND COMMISSIONING

Heavy duty servicing is for vehicles used under “harsh” conditions: door-to-door deliveries, intensive urban use (courier), short journeys with engine cold, dusty areas, ambient temperature over 30°C.

Service operations	500 kms or 1 months	Every 5000 kms or 12 months	Every 10000 kms
Heavy duty servicing	500 kms	Every 2500 kms	Every 5000 kms

Check

Throttle cable play	X	X	X
Steering column play	X	X	X
Operation of electrical equipment	X	X	X
Condition of front and rear brake hydraulic controls	X	X	X
Condition of fuel pipes	X	X	X
Condition of oil pipes	X	X	X
Tyre pressures	X		
Tyre condition, pressure and wear		X	X
Brake fluid level	X	X	X
Battery electrolyte level *	X	X	X
Coolant level	X	X	X
Engine oil level	X		
Tightness of nuts and bolts	X	X	X

Change

Spark plug		X	X
Inlet silencer/air filter**			
Front brake pads#			X
Rear brake pads *#			X
Drive pulley bearings and guides #		X	X
Transmission belt			X
Engine oil (+ clean strainer)		X	
Engine oil filter			X
Brake fluid and coolant**			

Check and lubricate

Driven pulley: moving flange and needle bush			X
Drive pulley: moving flange and rollers*			X

Reading the ECU fault codes

Injection and ABS/PBS system*	X	X	X
-------------------------------	---	---	---

Test machine

On road	X	X	X
---------	---	---	---

* depending on equipment

if necessary

** every 20000 km for the 50 cc (10000 if harsh use servicing) and every 40000 for the 125 cc (20000 km if harsh use servicing)

SPECIAL IMPORTANT POINTS

SPECIAL IMPORTANT POINTS

Oil and fuel

This engine is designed to run on 95 or 98 unleaded fuel only

Never run the machine with a petrol/oil mixture.

The oil used for the separate lubrication system is « Esso 2T Spécial » or « Esso 2T Spécial anti-fumée » recommended by the manufacturer

Starting up after overhauling the engine

The oil circuit bleed system (50 cc) must be checked with the diagnostic tool, the fuel pump bleeds itself automatically when the ignition is turned on

Starting should not be with a 2-stroke **mixture**, as the fuel pump and injectors are not designed to operate with oil.

When starting the engine hot or cold do not accelerate

Check the coolant level in the header tank

After road-testing the machine, check there are no fault codes left in the ECUs (read with diagnostic tool)

Electricity

All components of the electrical system are powered with 12 volts DC.

The battery must not be disconnected while the engine is running and the voltage must be at least 8.5 volts for the ECU to function and enable engine starting

To avoid any risk of forgetting to turn off the ignition after opening the saddle, the ignition key should be removed after each job

Special features

After changing the injection ECU or the throttle, the initialisation procedure must be carried out with the diagnostic tool

The ECU has a diagnostic function which via the instrument cluster Led or the diagnostic tool, enables reading of the faults in the memory

**The fuel inlet and injection manifold return pipes must only be replaced by genuine service parts.
The fuel pressure of 8 bars requires special pipes.
The fuel pipes must be changed if they show signs of wear, cracks, etc.
The clips are specific, they must always be changed each time they are removed and replaced with new genuine parts clips**

Note:

Before carrying out any work, leave the engine to cool for a minimum of 2 hours.

Petrol is highly inflammable, do not smoke in the working area and avoid proximity to flames or sparks.

Work in a clear and well-ventilated area.

TIGHTENING TORQUES

TIGHTENING TORQUES

Body panels

Front mudguard	0.8 to 1.2 mdaN
Handlebar cover	0.2 to 0.4 m.daN
Front legshields	0.2 to 0.4 m.daN
Rear shield	0.2 to 0.4 m.daN
Bottom panel	0.2 to 0.4 m.daN
Footboard	0.4 to 0.6 m.daN
Saddle storage compartment	0.4 to 0.6 m.daN
Rear panels	0.2 to 0.4 m.daN
Grab handle	2 to 2.5 m.daN
Rear mudguard	0.2 to 0.4 m.daN

Frame







Front wheel spindle	6 to 7 m.daN
Rear wheel bolt	8.5 to 9.5 m.daN
Rear wheel spindle nut	10 to 12 m.daN
Linkrod to engine pivot	4.3 to 5 m.daN
Linkrod to swingarm	4.3 to 5 m.daN
Engine-upper linkrod pivot	4.3 to 5 m.daN
Shock absorber top mount	2.4 to 2.6 m.daN
Shock absorber bottom mount	2.4 to 2.6 m.daN
Front and rear frame mounting nut	2 to 2.5 m.daN
Exhaust to cylinder mounting nut	1.5 to 1.8 m.daN
Exhaust to cylinder head mounting nut (125 cc)	1.5 to 1.8 m daN
Exhaust to casing mounting bolt	2 to 2.5 m.daN
Upper cone (in 2 operations)	3.8/2.3 mdaN
Upper cone locknut	Tighten manually
Steering locknut	7 to 8 m.daN
Front brake caliper	2.5 to 3.5 m.daN
Rear brake caliper	2 to 2.5 m.daN
Front disc brake	0.9 to 1 m.daN
Rear disc brake	0.9 to 1 m.daN
Handlebar	2.5 to 3.5 mdaN

Standard

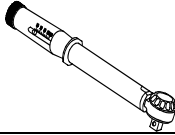
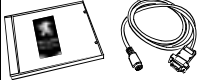
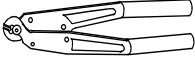
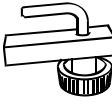
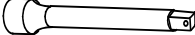
Nut and bolt 5 mm diameter	0.5 m.daN
Nut and bolt 6 mm diameter	1 m.daN
Nut and bolt 8 mm diameter	2.2 m.daN
Nut and bolt 10 mm diameter	3.5 m.daN
Nut and bolt 12 mm diameter	5.5 m.daN

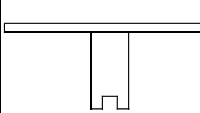
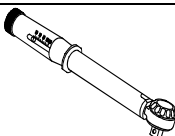
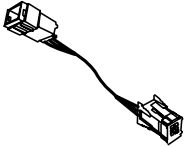
SPECIAL TOOLS

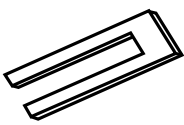
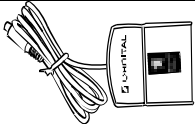
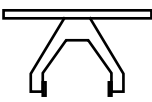
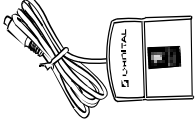
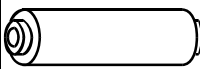
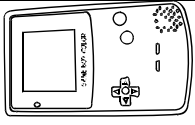
SPECIAL TOOLS

	Tool N°	Description	Used with				
	68994	Torque wrench 8 Nm to 54 Nm	extension 752235 adapter 752236		755990	Diagnostic tool update software	
	750539	Tie-wrap pliers			755996	hose clamp	
	752235	1/2 extension	69802 or 753977		756017	petrol injection power supply harness	
	752236	1/2-3/8 adapter	69802 or 753978		756715	Tank gauge spanner	
	753977	Torque wrench 30 Nm to 150 Nm	extension 752235 adapter 752237		756449	ABS/PBS interface cable for diagnostic tool	755878 755806 755807
	754086	Steering tool			756575	Piston locking fork	
	755806	Cartridge France	755878		756716	Tank ring spanner	
	755807	Cartridge Export	755878		756607	Fork seal fitting tool 125 cc	
	755878	Diagnostic tool (game boy colour)	755806 755807		756608	Fork seal fitting tool 50 cc	

INSTRUMENT CLUSTER

INSTRUMENT CLUSTER

Instrument cluster description

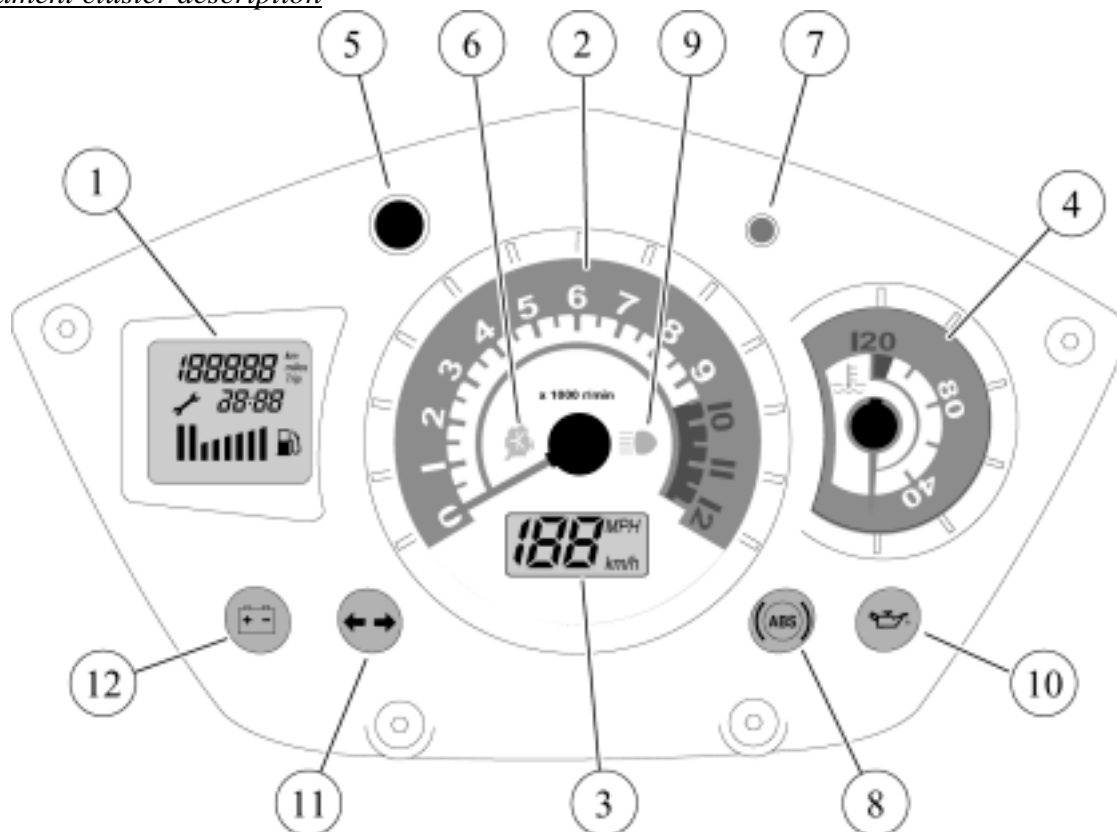

1. Multi-function display
2. Rev counter
3. Speedometer
4. Engine temperature gauge
5. Control button
6. Injection system diagnostic warning light
7. Transponder immobiliser dissuasion light
8. ABS/PBS system diagnostic warning light (125 cc)
9. Headlight warning light
10. Low oil level (50 cc) or oil pressure (125 cc) warning light
11. Direction indicator warning light
12. Battery charge warning light

When the ignition is turned on, the different functioning tests are carried out automatically for 5 seconds:

- Display of all of the multi-function display items (1) and the speed (3)
- Lighting of all the warning lights (except ABS/PBS depending on version)
- Test of rev counter stepper motors (2) and engine temperature (4) giving one sweep of the needles and zero reset where necessary

INSTRUMENT CLUSTER

Description of the multi-function display

- 13. Tripmeter (total or daily)
- 14. Tripmeter display
- 15. Type of unit used by the tripmeter
- 16. Clock
- 17. Maintenance indicator (spanner symbol)
- 18. Fuel gauge

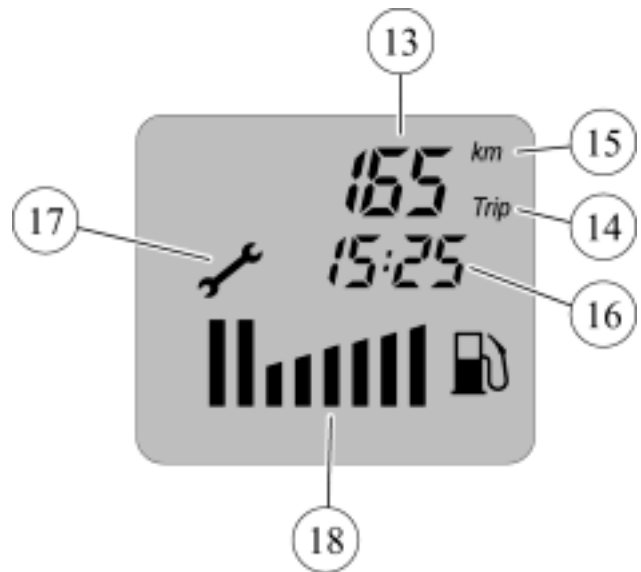

MULTI-FUNCTION DISPLAY FUNCTIONS AND SETTINGS

Setting and function change operations can only be carried out if the machine is stationary (engine not running) This is for safety reasons.

Changing from the total distance display to the daily display

The tripmeter (13) has two functions:

- Total distance (15) displays and memorises the total distance covered by the machine
- The tripmeter (14) displays and memorises the distance covered over a given period

With the ignition on, changeover from the main to the daily distance and inversely is by briefly pressing the control button (5)

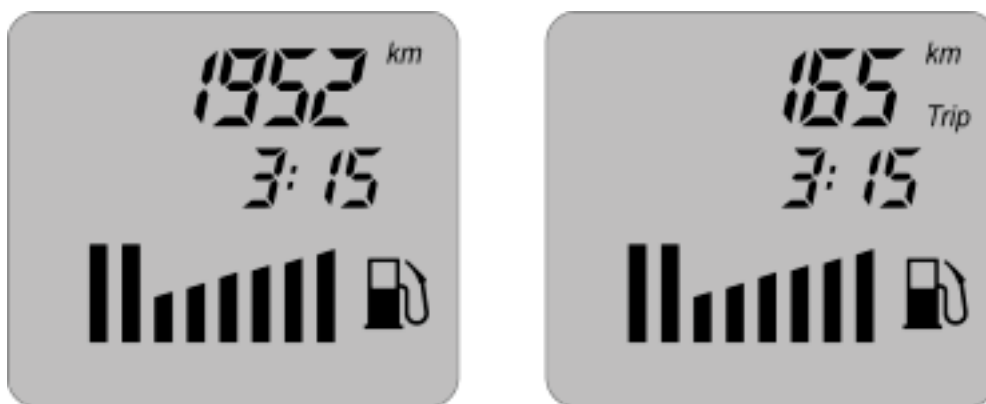

With the ignition on, reset of the daily tripmeter is by pressing the control button for more than 3 seconds

INSTRUMENT CLUSTER

Changing the distance unit

Changing the distance unit (km or miles) is as follows:

- Ignition off, hold down the control button (5) and turn on the ignition, the distance unit flashes
- Select the unit by briefly pressing the control button, the distance unit changes from “km” to “miles” or inversely.
- Turn off ignition to confirm



Setting the clock

The time can only be set in the tripmeter total distance position

- Ignition on, press the button (5) until the time flashes
- Set the time by successive pushes on the control button
- To change the tenths of a minute, press the button until the minute tenths flash
- Change the minute tenths by pressing as required on the button
- Proceed in the same way to set the minutes
- Press the button for more than 3 seconds to validate the clock setting



INSTRUMENT CLUSTER

Maintenance function

Every 5000 km a « spanner » symbol appears informing the rider that his machine is due for service
After servicing the machine, erase the spanner symbol as follows:

- Ignition off, hold down the button (5) and turn on the ignition, the spanner symbol flashes
- Release the control button
- Press the button again for at least 5 seconds, the spanner symbol goes off

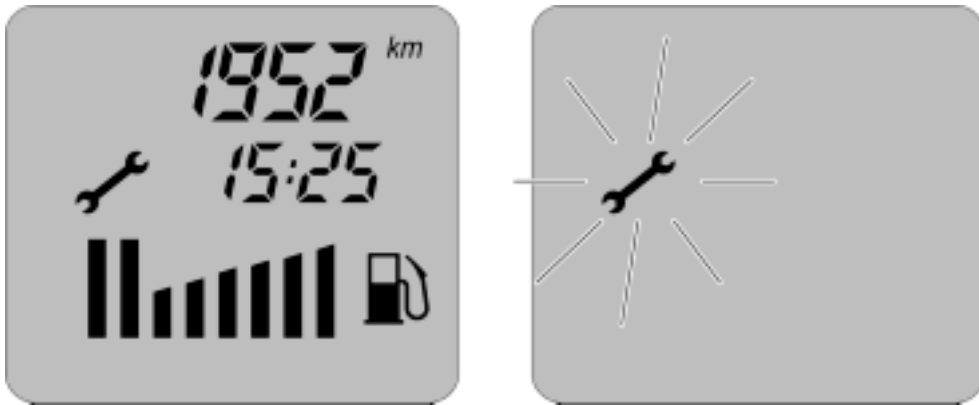

Fuel gauge self-diagnostic

If the fuel system is cut off from the fuel gauge, when the ignition is turned on, the display segments light one after the other

CONTROL CABLE AND HARNESS ROUTINGS

CONTROL CABLE AND HARNESS ROUTINGS

ABS/PBS panel

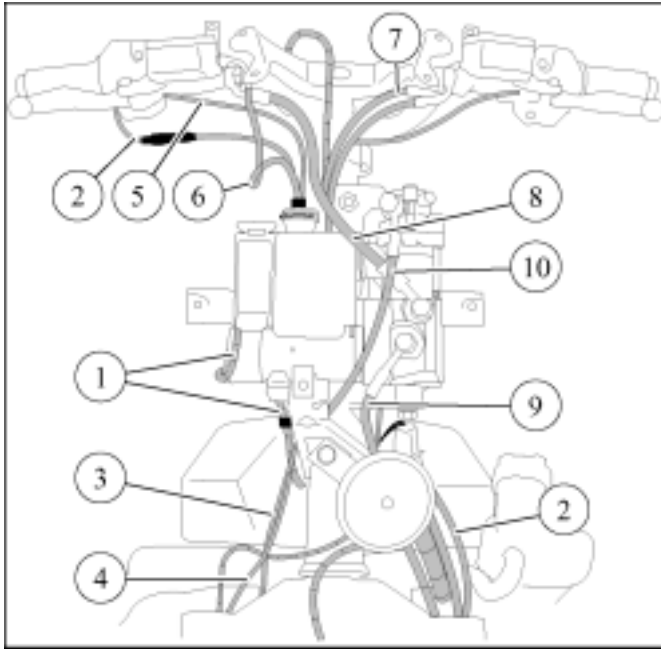

1. Main harness
2. Throttle control
3. Transponder antenna
4. Speed sensor
5. Brake light switch
6. ABS/PBS brake module reservoir feed pipe
7. Rear brake pipe
8. Right master cylinder to module brake pipe
9. Module brake pipe to front caliper
10. Left master cylinder to module brake pipe

Conventional braking panel

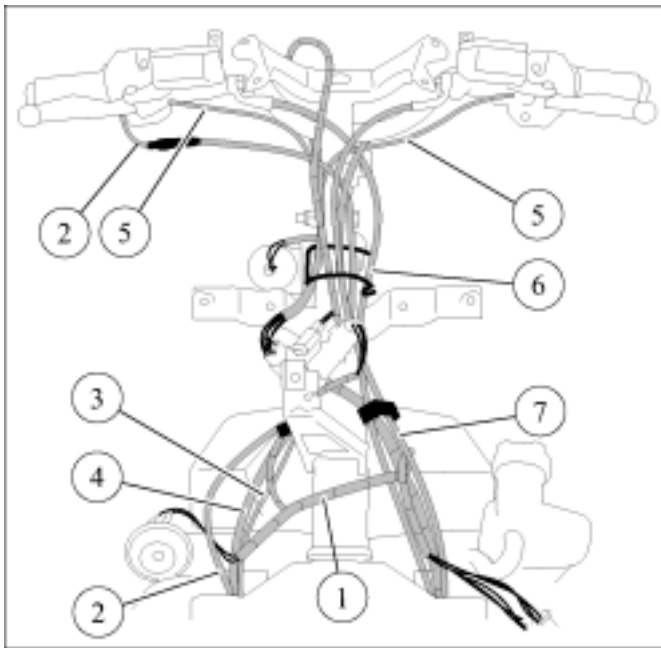

1. Main harness
2. Throttle control
3. Transponder antenna
4. Speed sensor
5. Brake light switch
6. Front brake pipe
7. Rear brake pipe

CONTROL CABLE AND HARNESS ROUTINGS

Right-hand side 50 cc

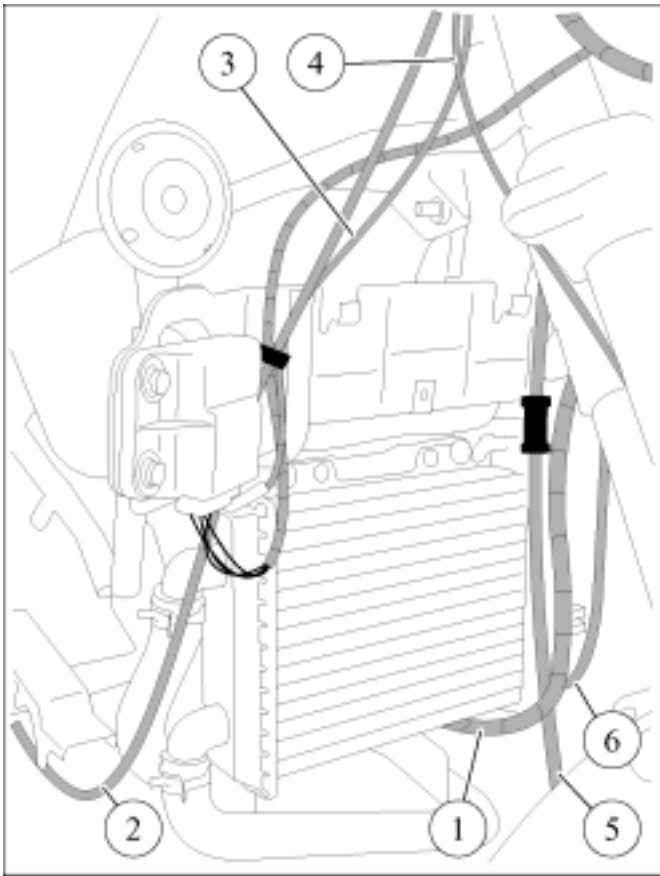

1. Main harness
2. Throttle cable (50 cc)
3. Transponder antenna
4. Speed sensor
5. Front brake pipe
6. Rear brake pipe
7. Fuel feed pipe

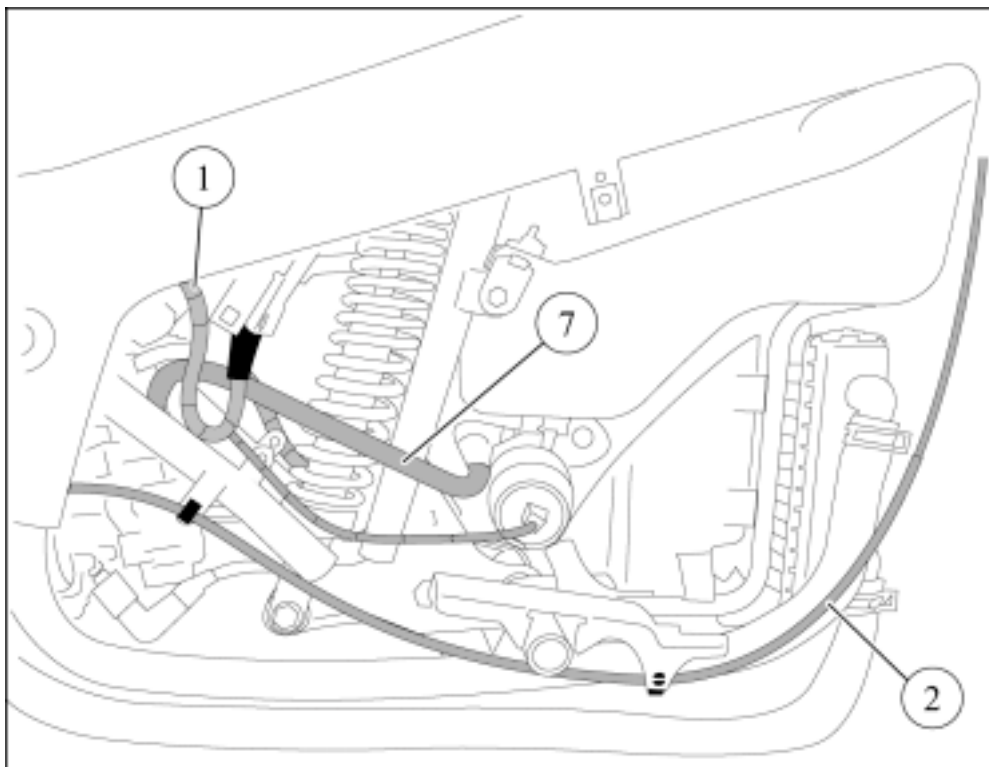

CONTROL CABLE AND HARNESS ROUTINGS

Left-hand side 125 cc

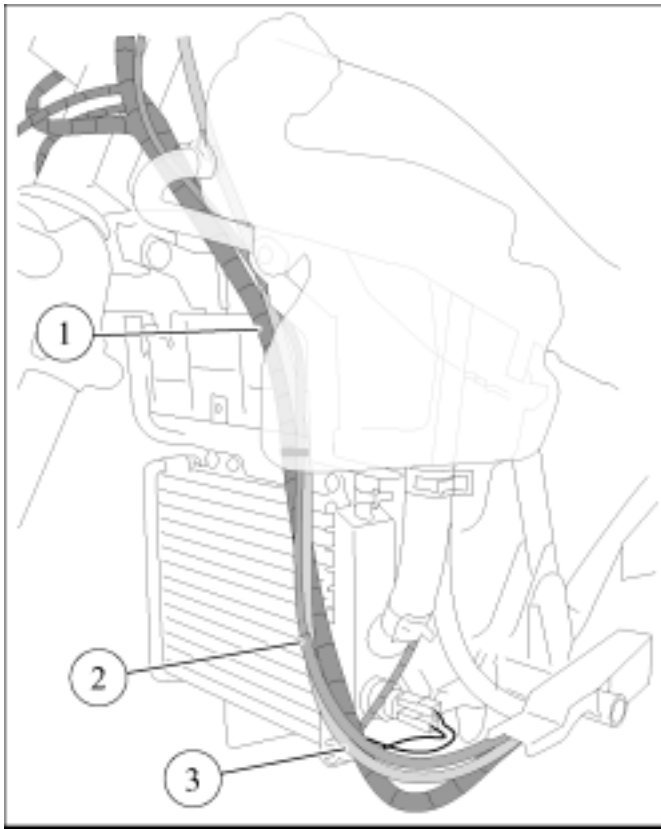

1. Main harness
2. Throttle cable (125 cc)
3. Rear brake pipe
4. Fuel supply pipe
5. Air pressure slave pipe
6. Fuel overflow pipe

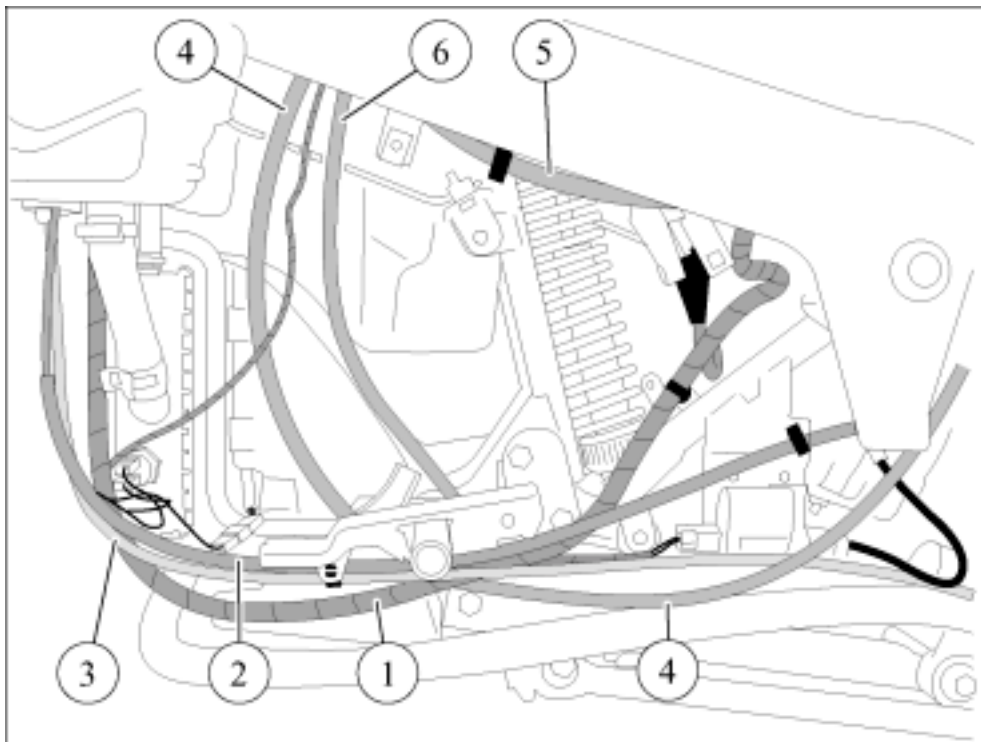

CONTROL CABLE AND HARNESS ROUTINGS

Rear right

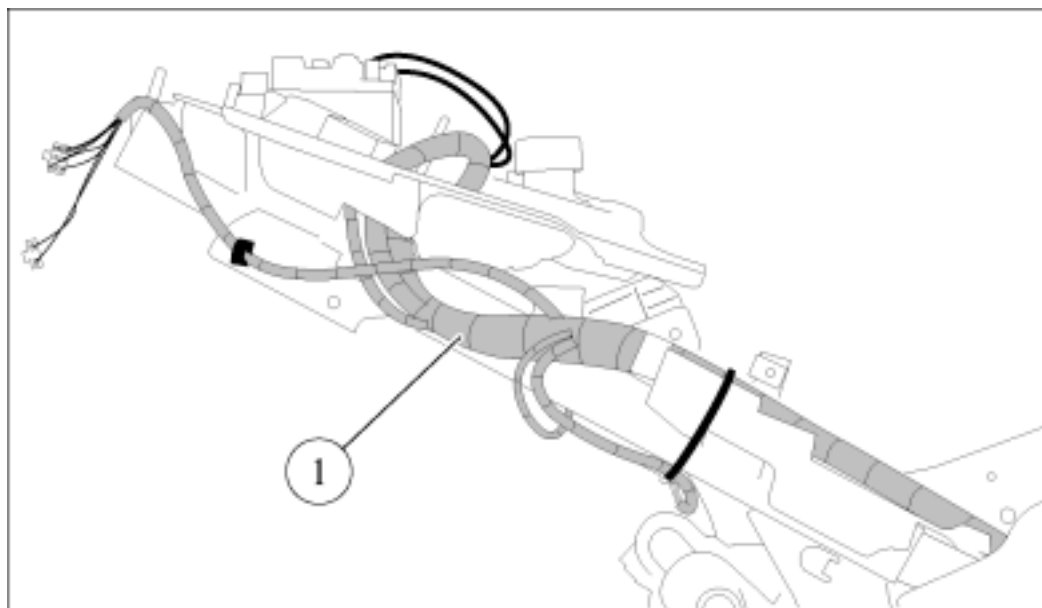

1. Main harness

Rear centre

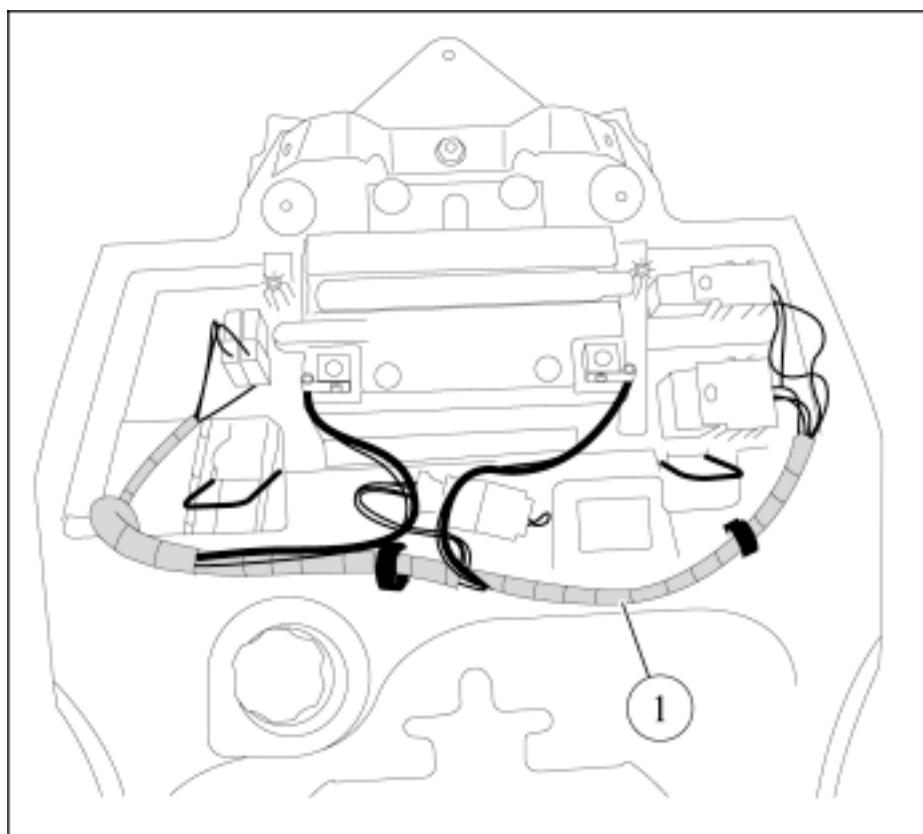

1. Main harness



LOCATION OF COMPONENTS

LOCATION OF COMPONENTS

50 cc

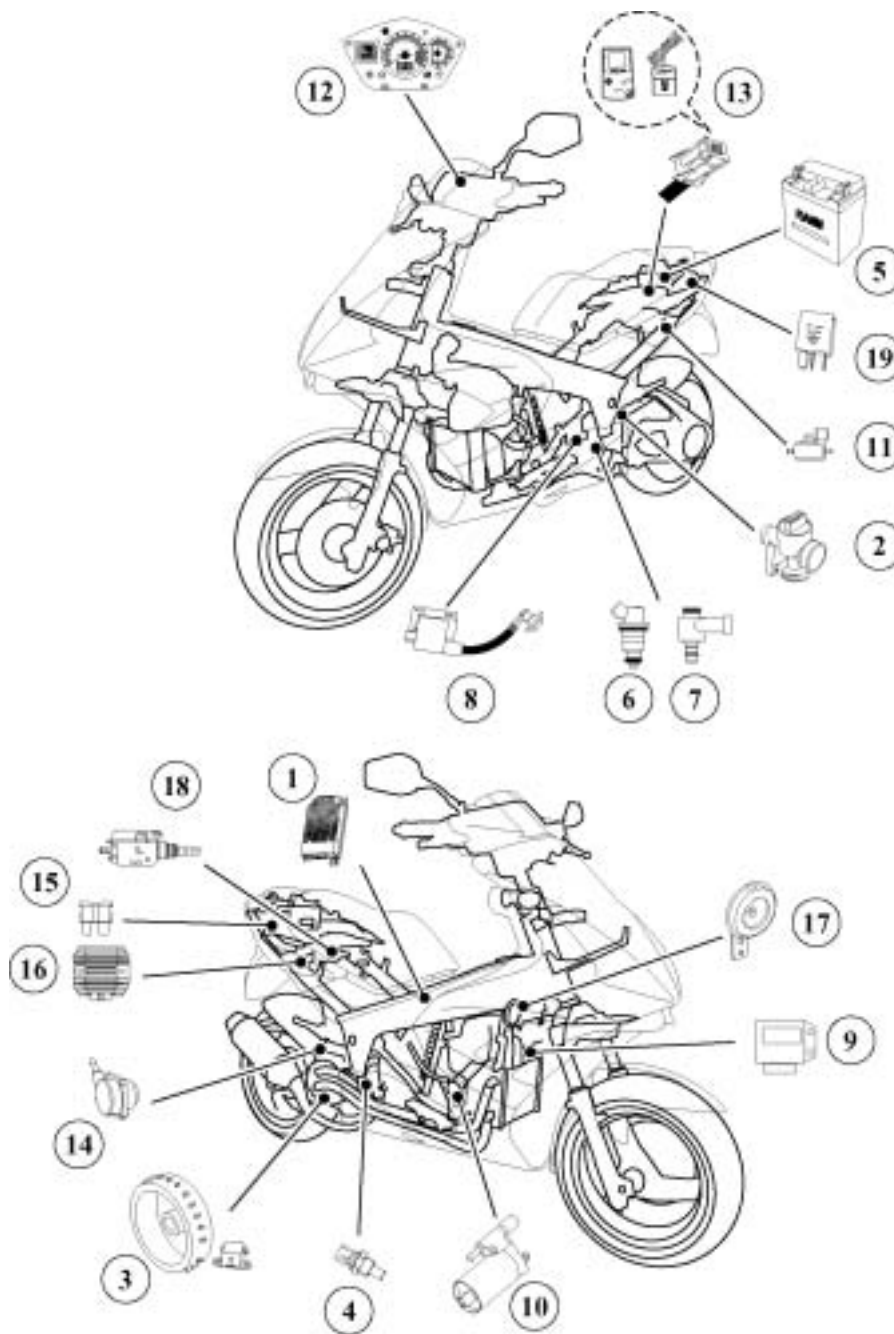

- | | |
|-------------------------------------|------------------------------|
| 1. Injection ECU | 11. Oil pump |
| 2. Throttle unit | 12. Diagnostic light |
| 3. Engine position and speed sensor | 13. Diagnostic plug |
| 4. Temperature sensor | 14. Air compressor |
| 5. Battery | 15. Fuses |
| 6. Fuel injector | 16. Voltage regulator |
| 7. Air injector | 17. Horn |
| 8. Ignition coil | 18. Saddle lock |
| 9. Immobiliser module | 19. Starter / lighting relay |
| 10. Fuel pump | |

LOCATION OF COMPONENTS

125 cc

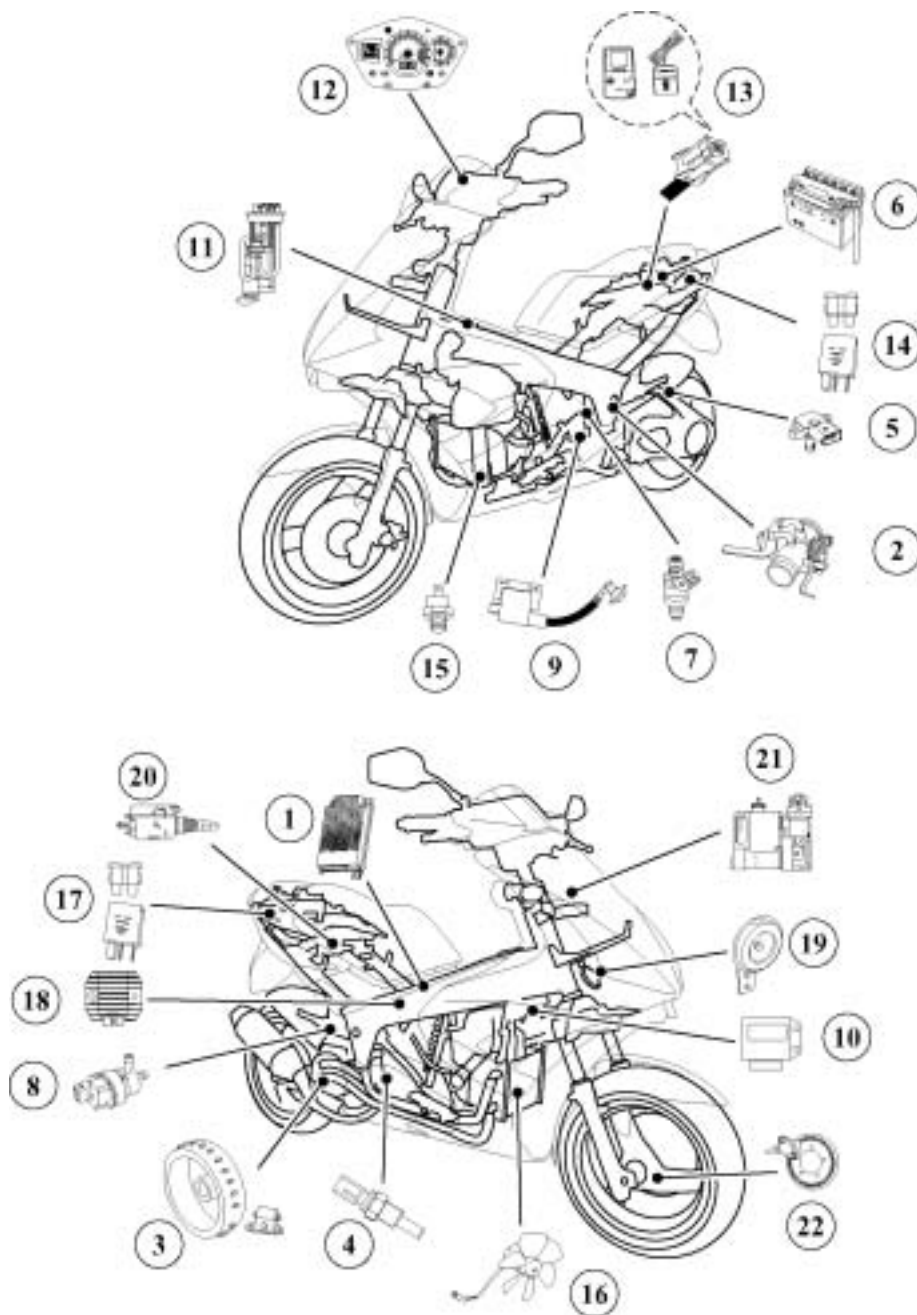

- | | |
|--|--|
| 1. Injection ECU | 12. Diagnostic light |
| 2. Throttle unit | 13. Diagnostic plug |
| 3. Engine position and speed sensor | 14. Fuel pump relay, ABS/PBS, lighting, 25A fuse |
| 4. Temperature sensor | 15. Heat switch |
| 5. Air pressure and air temperature sensor | 16. Motor-driven fan |
| 6. Battery | 17. Starter relay, 15 A fuse |
| 7. Fuel injector | 18. Voltage regulator |
| 8. Idle control valve | 19. Horn |
| 9. Ignition coil | 20. Saddle lock |
| 10. Immobiliser module | 21. ABS/PBS module |
| 11. Fuel pump | 22. Vehicle speed sensor and ABS/PBS |

BODY

BODY

Location of body components (50 and 125 cc)

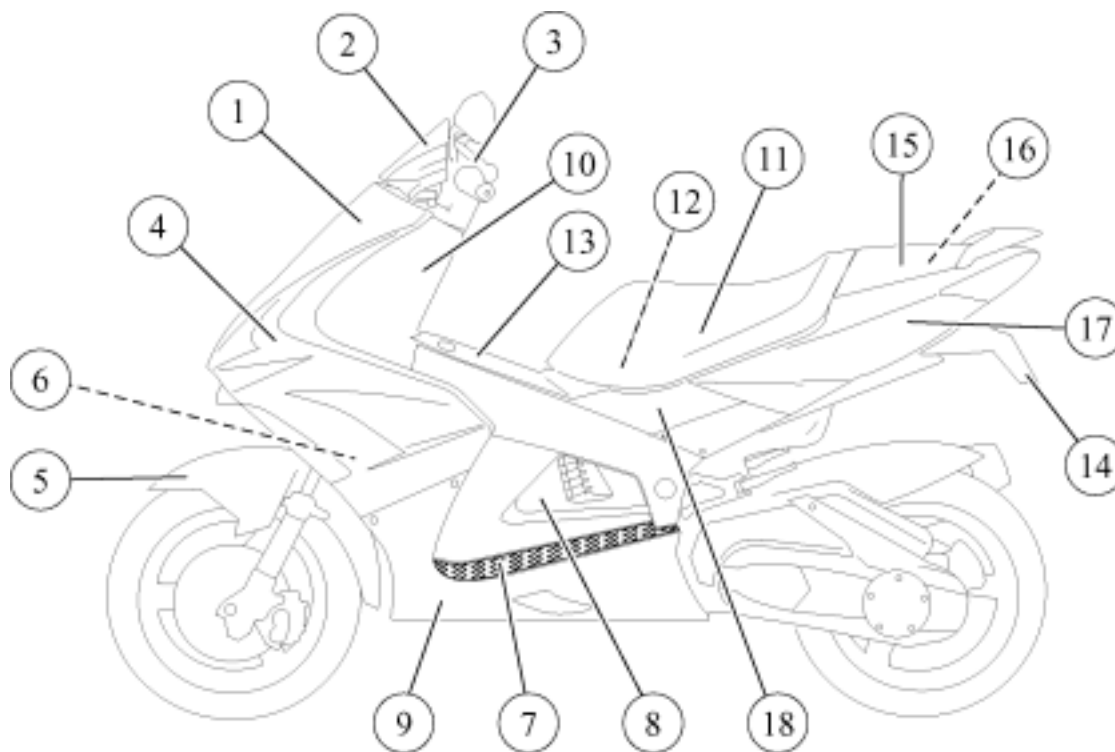

Body component sequence of disassembly (50 and 125 cc)

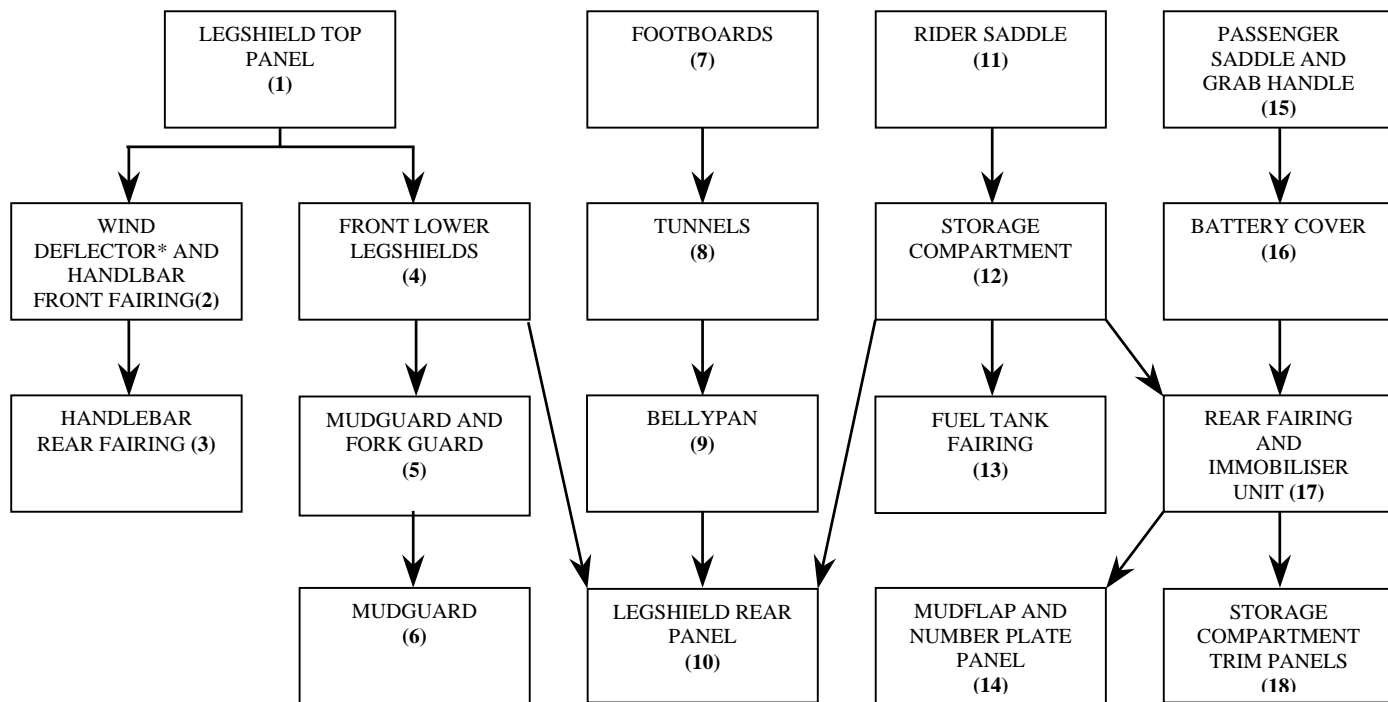

* Depending on model

BODY

Removal of front lower legshields (50 and 125 cc) Procedure 1

- Remove the ignition key
- Remove the front upper legshield (1) (3 screws)
- Disconnect the lighting and direction indicator connections

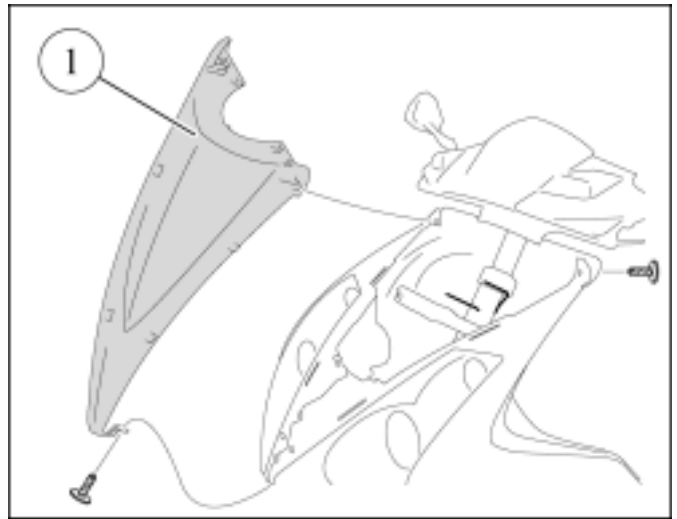

- Remove the front lower left legshield (2) (3 screws), including the 2 fixing it to the RH legshield (3)
- Remove the front lower RH legshield (3 screws)

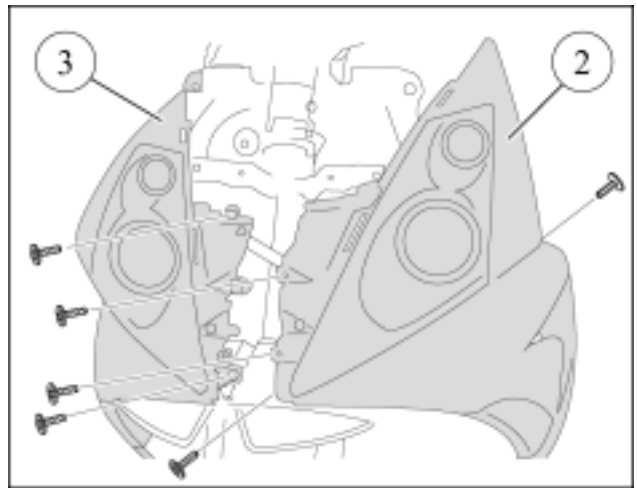

Removal of the headlight and sidelight assemblies (50 and 125 cc)

- Remove the front lower legshields (see procedure 1)
- Remove the headlight and sidelight assemblies (3 screws each)

Method for fitting the lower legshield bracket (50 and 125 cc)

- Fit the support bracket (1) with its bolt (2) to the frame but do not tighten it
- Fit the lower RH legshield (3) with the fixing screws
- Adjust the support bracket to the legshield and tighten its frame fixing screw

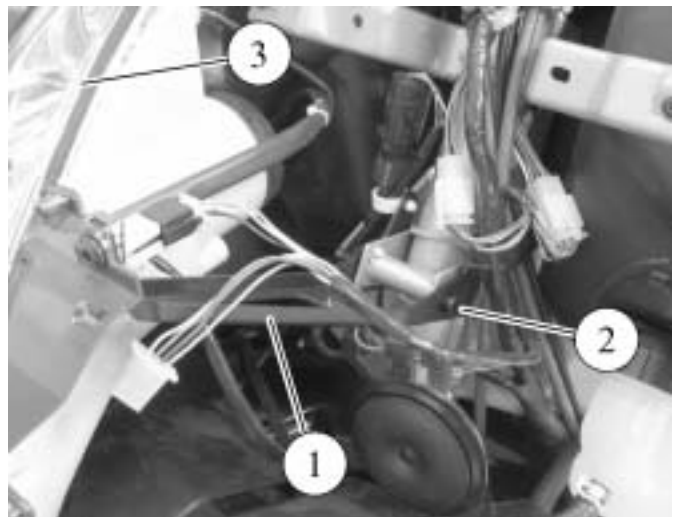

Removal of the storage compartment (50 and 125 cc) Procedure 2

- Open the saddle (1)
- Remove the saddle strut upper securing nut (2)
- Remove the saddle (1) (2 nuts)
- Remove the storage compartment (3) (6 nuts)

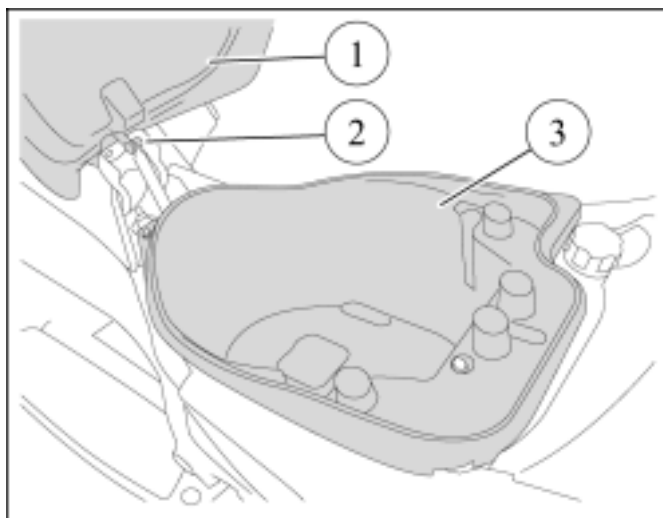

Removal of the shield)(50 and 125 cc) Procedure 3

- Remove the front lower legshields (see procedure 1)
- Remove the storage compartment (see procedure 2)
- Remove the tank cap trim (1) (3 screws)
- Remove the tank cover (2) (5 screws)

Note: When removing the trim 3 screws, take care not to release the 3 nuts held in place in the tank filler ring

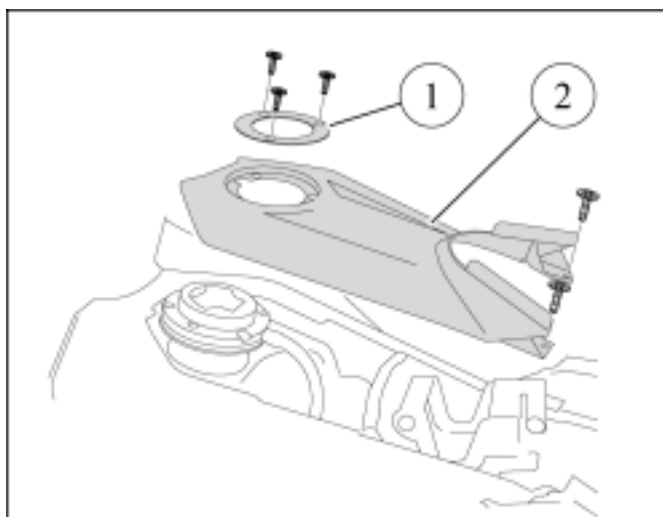

- To remove the footboards (3) (2 screws each)

Method for removing the footboards

- Unclip the outer part of the footboard starting at the rear (A)
- Unclip the footboard from the frame bottom
- Raise the footboard by levering on the front end (B) to release it from the rear shield

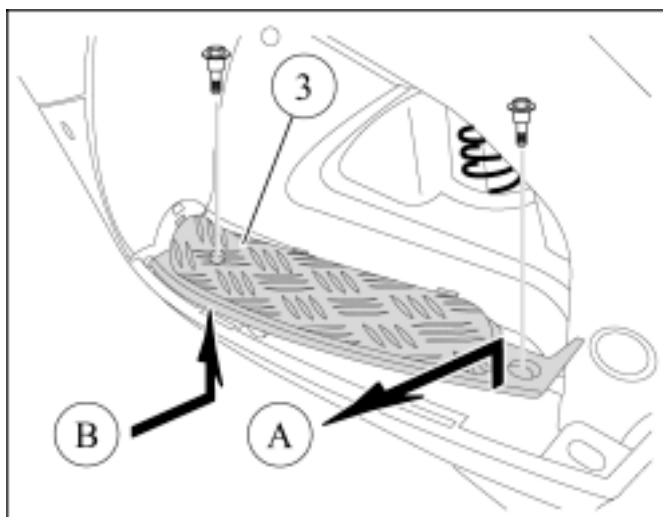

BODY

- Remove the tunnels (4) (3 screws each) by unclipping starting at the rear upper part

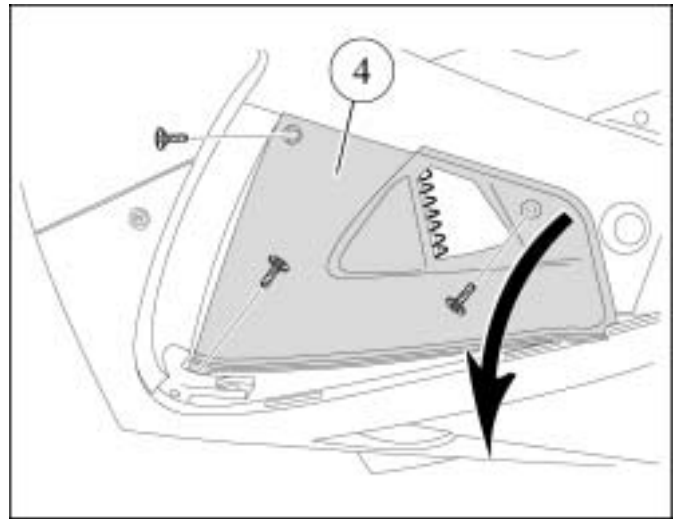

- Remove the bottom panels (5) (3 screws)

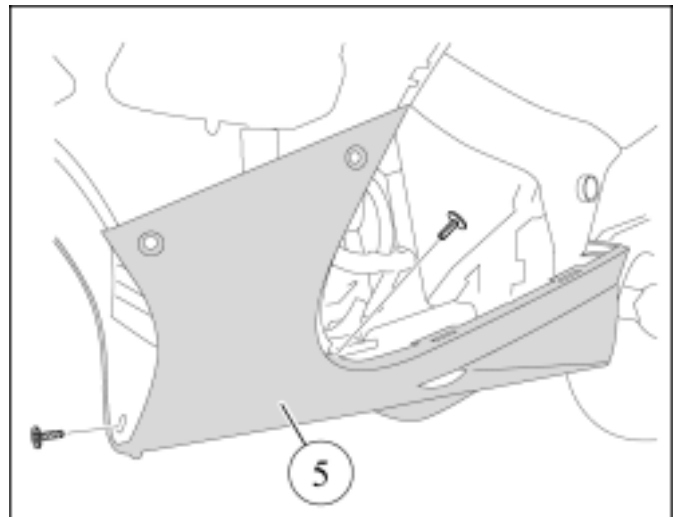

BODY

- Remove the rear shield (6) (3 screws) including 1 screw next to the filler cap

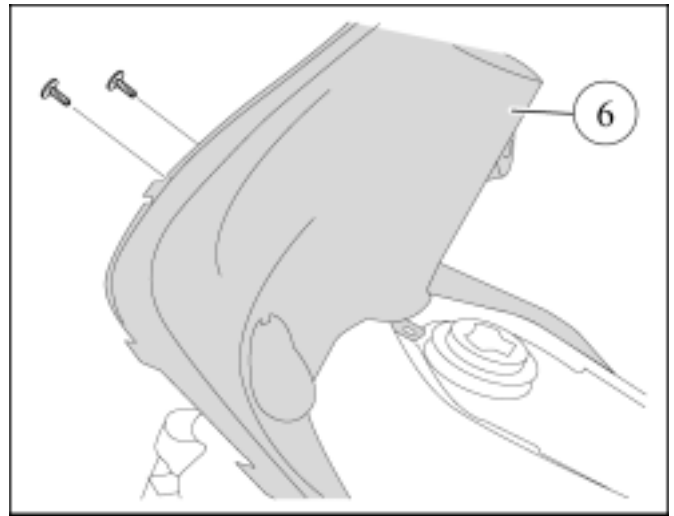

Removal of the rear cover assembly and mudflap (50 and 125 cc) Procedure 4

- Remove the storage compartment (see procedure 2)
- Remove the ignition key
- Remove the passenger seat (2 bolts)
- Remove the rear handle (3 nuts)
- Remove the rear cover (1) 8 fixing screws
- Disconnect the rear light and direction indicator connections (and number plate light depending on model)
- Remove the rear cover assembly (unclip the rear cover from the storage compartment trim, fed one side of the panel under the battery bracket, pull the cover clear by turning it on the same side)

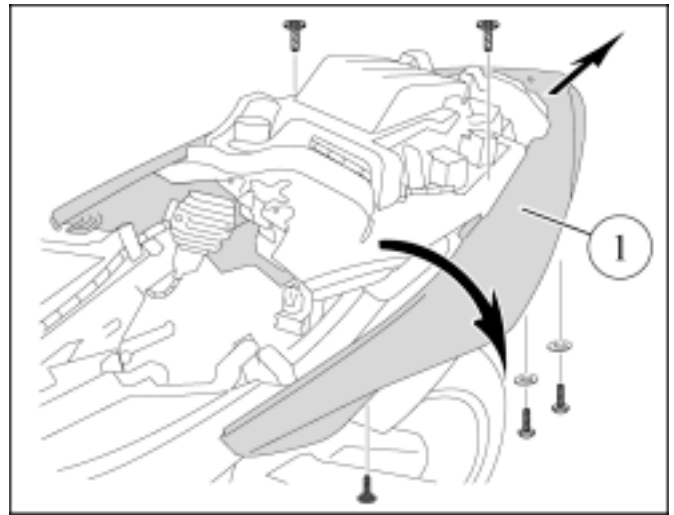

Removal of the rear light / storage compartment trim (50 and 125 cc)

- Remove the rear cover assembly (see procedure 4)
- Remove the rear light
- Remove the storage compartment trim (1) 4 screws
- Unclip the compartment trim from the frame to remove it

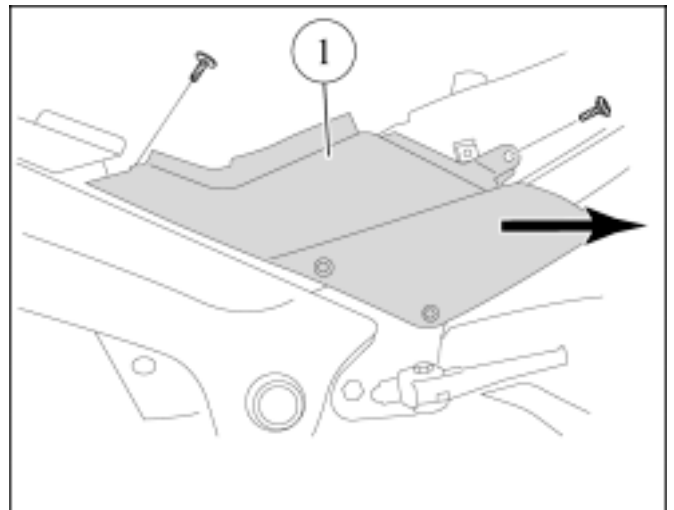

FRAME

FRAME

Removal of the rear frame (50 cc)

- Remove the rear cover assembly (see procedure 4)
- Remove the battery cover
- Disconnect and remove the battery
- Unclip the battery bracket harness without disconnecting the components
- Remove the battery bracket (1)
- Remove the 2 storage compartment (2) trim pieces

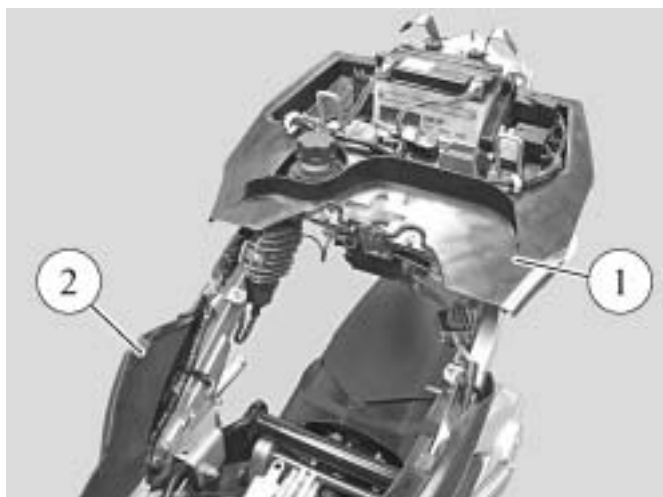

- Remove the regulator (3), the oil pump (4) after disconnecting it, and the saddle lock actuator (5)
- Disconnect the oil level low switch (6)
- Remove the oil tank (7)

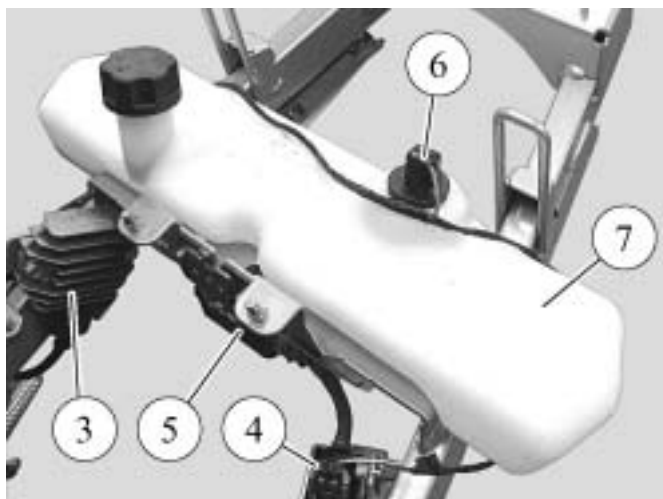

- Remove the 4 frame fixing nuts and bolts (8)
- Remove the rear frame
- Remove the nuts, the footboard with the caps and the saddle lock from the rear frame

Note: When refitting, the storage compartment trim must be fitted in position before the rear cover panel assembly

The regulator must be connected and its protection fitted before fixing to its bracket

There must be no air bubbles in the feed pipe before connecting it to the oil pump

Check: Using the diagnostic tool, check for fault codes, clear them if necessary

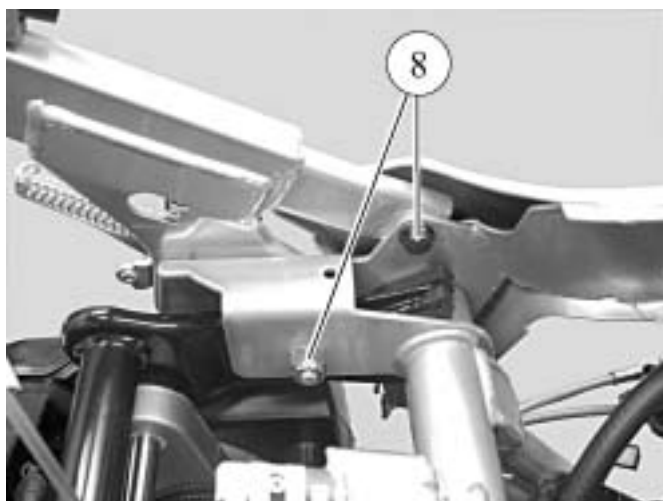

FRAME

Removal of the frame (50 cc)

This method is used only when changing the main frame, with the removal of several assemblies

When changing the frame due to an accident, the method must be completed by the repair or replacement of damaged items

- Remove the passenger seat
- Remove the battery cover
- Disconnect and remove the battery
- Remove the rear shield panel (see procedure 3)
- Remove the handlebar front and rear covers
- Remove the fork guard
- Remove the mudguard
- Unclip and disconnect the main harness from the front part of the machine, and from the components around the engine
- Disconnect the separate lubrication oil pipe from the engine casing
- Remove the frame 4 fixing bolts
- Remove the complete rear frame with the main harness

- Remove the front caliper and braking limit but do not disconnect them
- Remove the handlebar assembly without disconnecting the hydraulic controls

- Remove the radiator/bracket/header tank assembly



FRAME

- Disconnect the fuel tank sender unit return pipe
- Using tool part number 755996 clamp the fuel supply hose between the tank and the fuel pump
- Remove the fuel tank



- Remove the saddle pivot
- Remove the high voltage coil
- Remove the shock absorber upper mount
- Remove the swingarm to frame mount
- Pull back the power unit

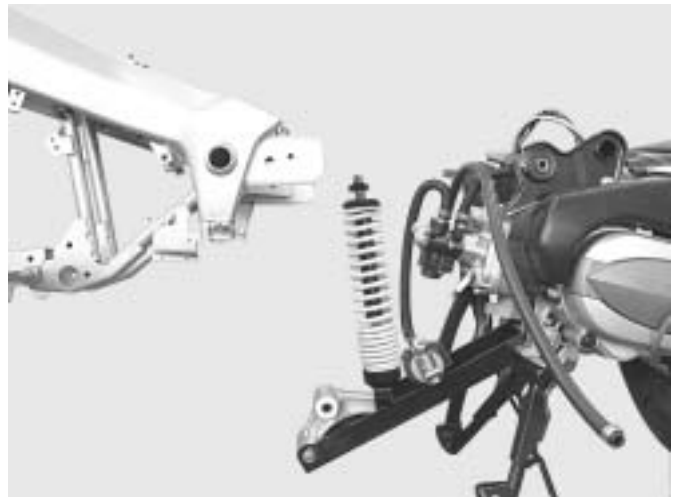

- Remove the fork assembly with the wheel

Note: Self-lubricating captive balls are fitted in the lower race

- Remove the remaining items from the frame, cage nuts, plastic inserts, ignition key switch, manufacturer's plate, lower cover brackets, steering cups



MISCELLANEOUS OPERATIONS

MISCELLANEOUS OPERATIONS

Removal of the oil tank (50 cc) or oil separator (125 cc), the saddle lock (50 and 125 cc)

- Remove the rear cover assembly (see procedure 4)
- Unclip the harness from the battery bracket without disconnecting the components
- Remove the battery cover
- Disconnect and remove the battery
- Remove the battery bracket
- Disconnect the oil level low switch
- Disconnect the oil pump
- Remove the oil tank (1) and/or the saddle lock (2)

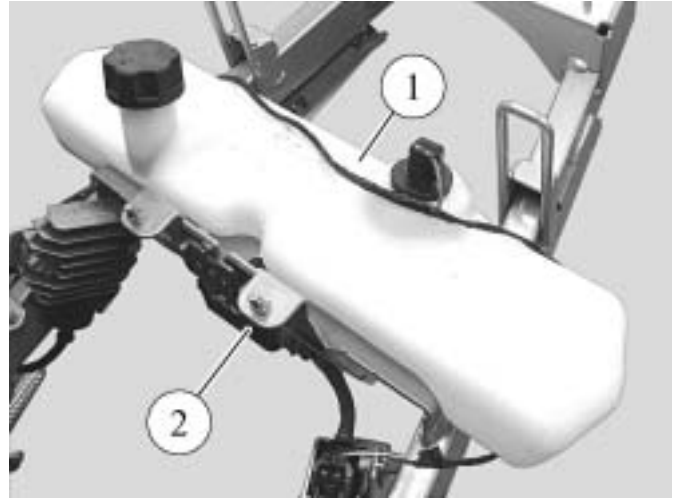

Note: When refitting the oil tank ensure there are no air bubbles in the pump feed pipe before connecting it

To remove the oil filter (50 cc)

- Remove the storage compartment (see procedure 2)
- Remove the oil filter (1)

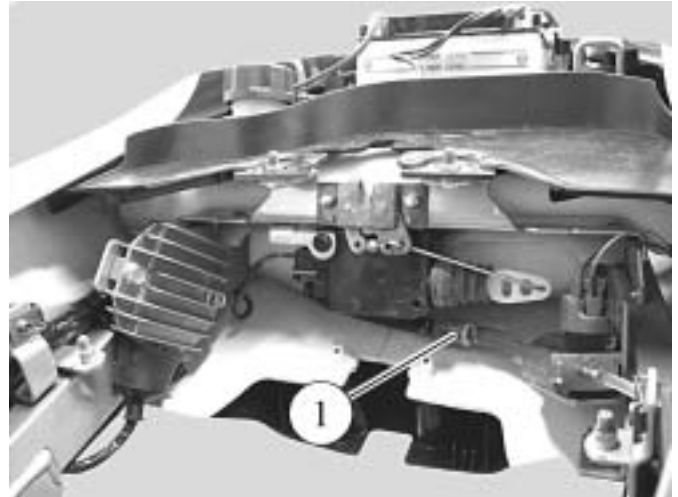

Note: When refitting ensure there are no air bubbles in the oil filter in its feed pipes before reconnecting the to the oil pump

To remove the header tank (50 and 125 cc)

- Remove the front lower legshields (see procedure 1)
- Drain the cooling system
- Disconnect the header tank pipes
- Remove the upper fixing bolts
- Clear the header tank (1) from the bracket guides and rear shield
- Remove the header tank

Note: When refitting, locate the header tank positioning pins (A) and the window (B) in the rear shield and in the radiator bracket

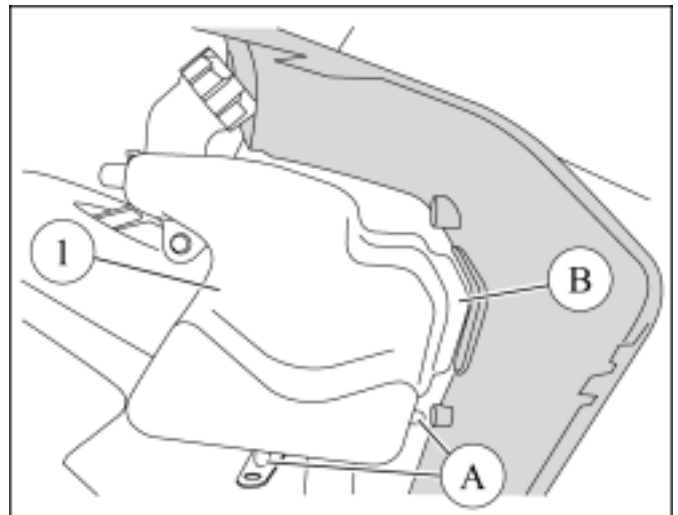

MISCELLANEOUS OPERATIONS

Removal of the radiator / radiator bracket (50 and 125 cc)

- Remove the front lower legshields (see procedure 1)
- Remove the rear shield panel (see procedure 3)
- Remove the fork guard (1) 2 fixing bolts without removing the guard
- Remove the mudguard (2)
- Drain off the coolant
- Disconnect the radiator cooling system 4 pipes (3)

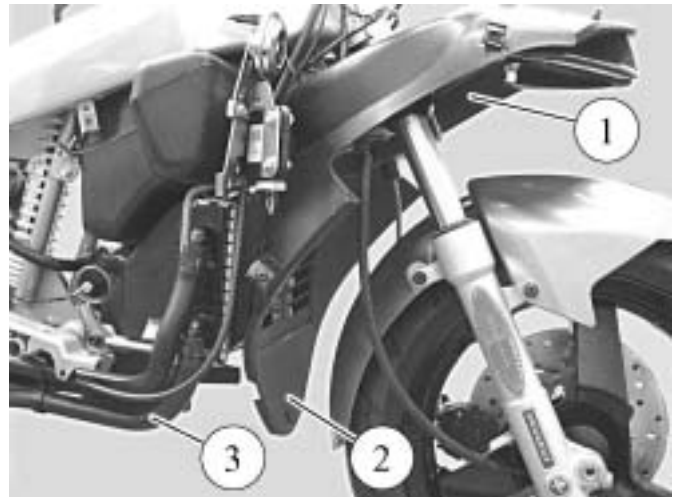

- Remove the radiator (4) (4 bolts)
- Unclip the deflector (5)
- Disconnect the horn and immobiliser unit
- Unclip the harness
- Remove the radiator bracket (3 bolts) with its components (immobiliser unit, horn and header tank)

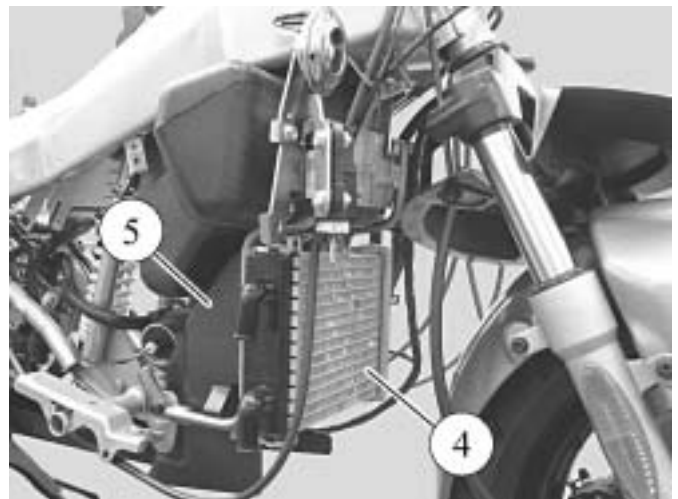

MISCELLANEOUS OPERATIONS

Removal of the fuel gauge (50 cc)

- Remove the storage compartment (see procedure 2)
- Remove the tank cover panel (5 screws)
- Remove the saddle pivot bracket (2 nuts)
- Disconnect the fuel gauge (1)
- Disconnect the return and vent pipes (2) from the sender unit

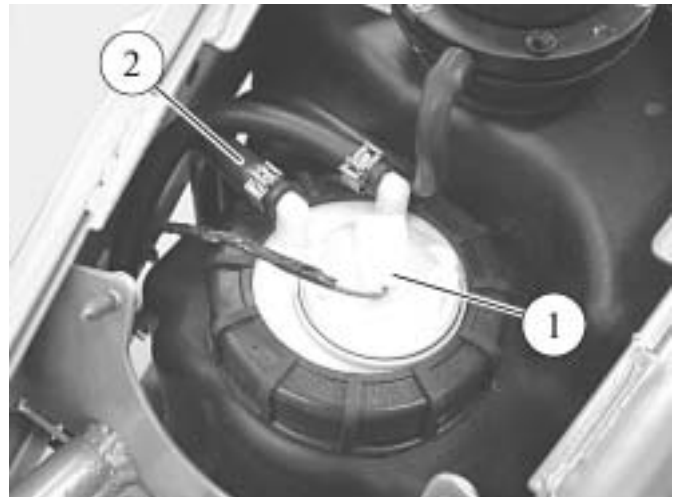

- Unscrew and remove the fuel sender unit and its seal using plug wrench part number 756716

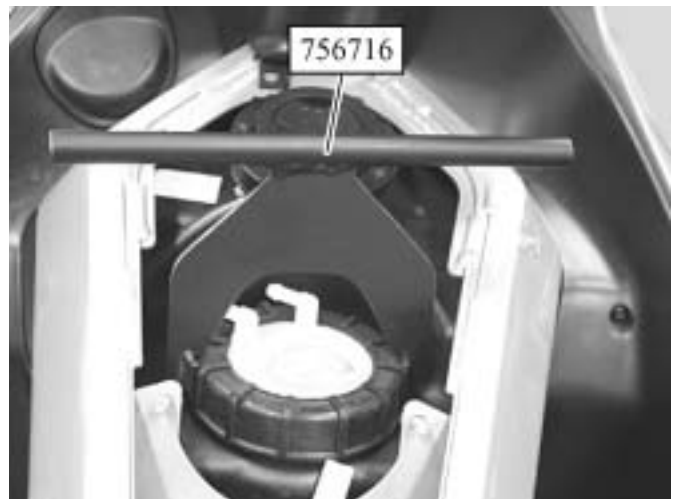

Reassembly: Re-assemble in the reverse order to dismantling

- Tighten the fuel sender unit using plug wrench part number 756716 in order to position the arrow (A) between the marks (B) on the tank

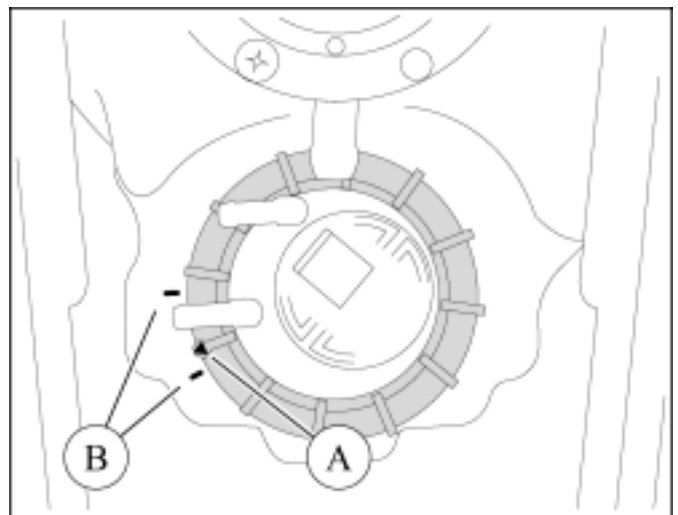

MISCELLANEOUS OPERATIONS

Removal of the strainer (50 cc)

- Remove the storage compartment (see procedure 2)
- Remove the tank cover panel (5 screws)
- Remove the saddle pivot bracket (2 nuts)
- Remove the footboard and the left tunnel
- Disconnect the fuel gauge (1)
- Disconnect the vent pipe (2) from the sender unit and put into a container in order to drain the tank
- Disconnect the return pipe (3) from the sender unit
- Unscrew and remove the sender unit and its seal using tool 756716
- Remove the strainer (4) by passing one hand inside the sender unit, wearing a protective glove
- Clean or change the strainer in accordance with the service instructions

Note: When refitting tighten the sender unit using tool part number 756716 as described above

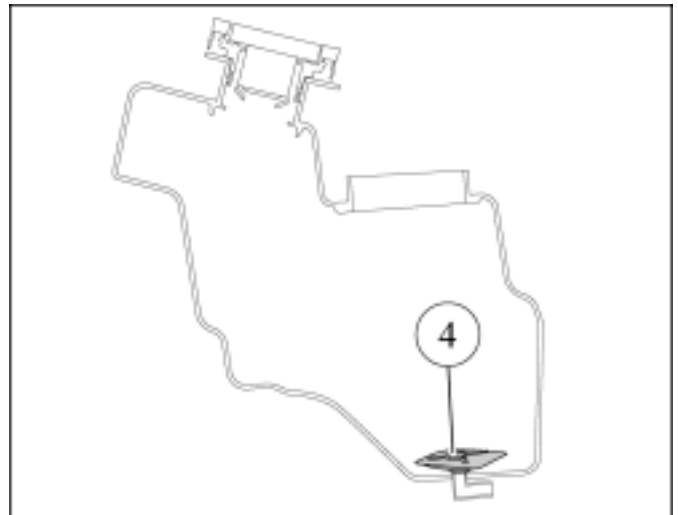
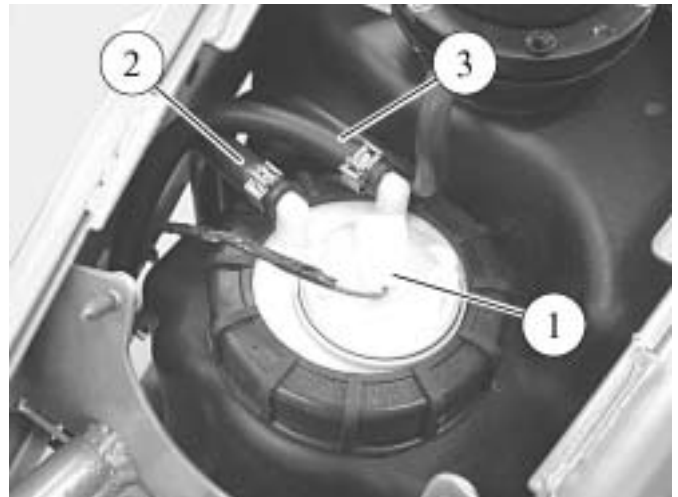

MISCELLANEOUS OPERATIONS

Removal of the fuel tank filler ring (50 and 125 cc)

- Remove the storage compartment (see procedure 2)
- Remove the tank filler cap (3 screws)
- Remove the filler cap trim
- Remove the tank cover panel (5 screws)
- Remove the tank filler ring (1) (3 screws)

Note: Mark the fitting position of the filler ring on the tank

The filler ring is clipped into the tank, the assembly is sealed by 2 O-rings (2)

When removing the trim 3 screws, take care not to release the 3 nuts held in place in the tank filler ring

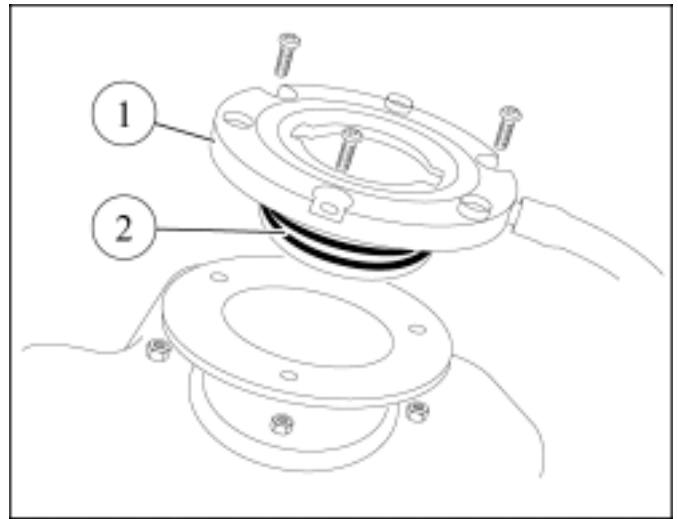

Removal of the fuel tank (50 cc)

- Remove the front lower legshield assembly (see procedure 1)
- Remove the rear shield panel (see procedure 3)
- Remove the radiator / deflector / bracket assembly
- Remove the injection manifold
- Using the injector actuator, drop the fuel pressure in the circuit (see procedure 6)
- Disconnect the fuel gauge (1)
- Disconnect the return pipe (2) from the sender unit

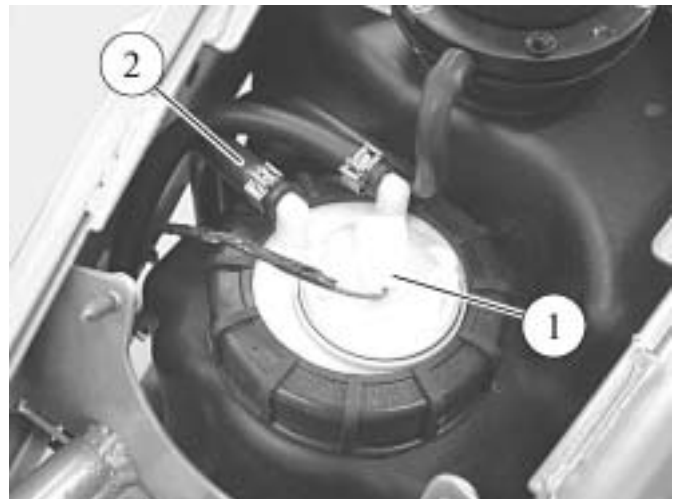

- Disconnect the fuel gauge (3)
- Disconnect the pump (4) from its bracket
- Disconnect the fuel pump output hose (5)

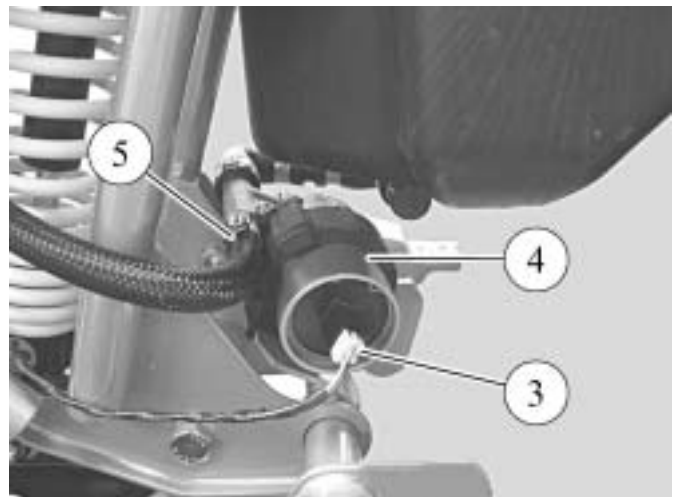

MISCELLANEOUS OPERATIONS

- Remove the tank upper fixing bolts (6)
- Remove the tank to frame 2 fixing brackets (7)
- Remove the tank with the fixing lugs, the fuel pump, the feed hoses and the cap

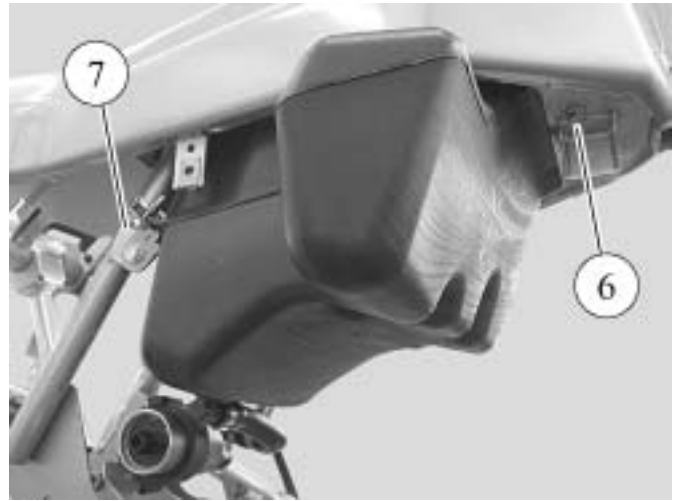

Removal of the central shock absorber / from the swingarm (50 and 125 cc)

- Remove the storage compartment (see procedure 2)
- Remove the tank cover panel (5 screws)
- Remove the footboard (4 screws)
- Remove the tunnels (4 screws)
- Remove the bottom panels (7 bis)
- Remove the saddle pivot bracket (1) (2 nuts)
- Remove the shock absorber upper mount (2)

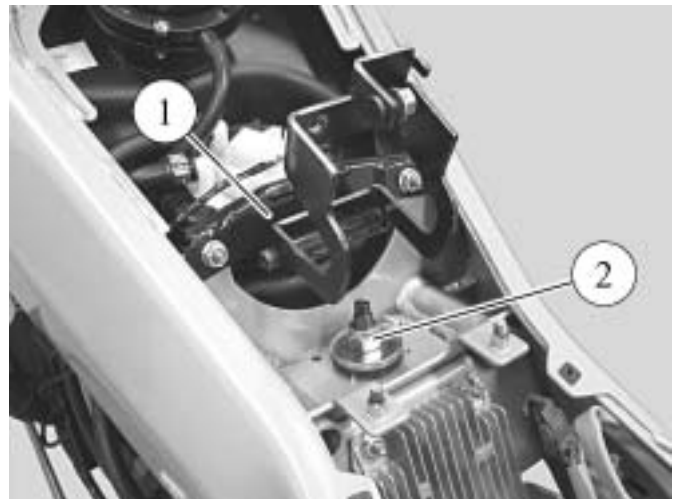

- Remove the linkrod to swingarm (4) mount (3)
- Remove the shock absorber lower mount (5)
- Remove the shock absorber
- Remove the swingarm to frame mount (6)
- Remove the swingarm

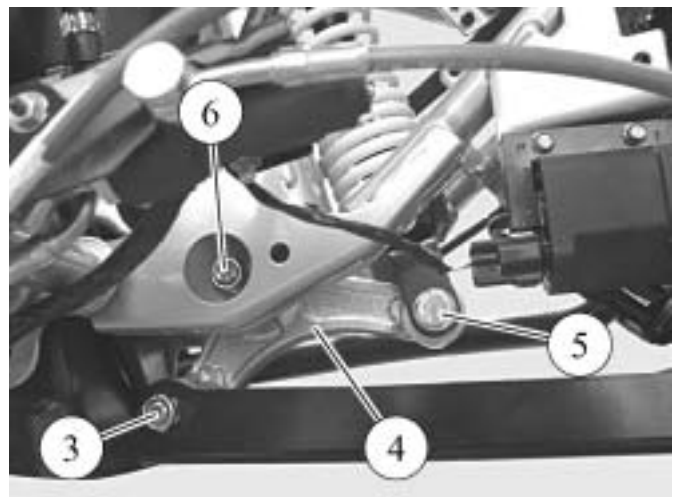

Note: We recommend greasing all needle bearings when refitting these parts

MISCELLANEOUS OPERATIONS

Removal of the radiator deflector (50 cc)

- Remove the footboards (4 screws)
- Remove the tunnels (4 screws)
- Remove the bottom panels (7 bis)
- Unclip the deflector (1) from the radiator bracket and pull it downwards

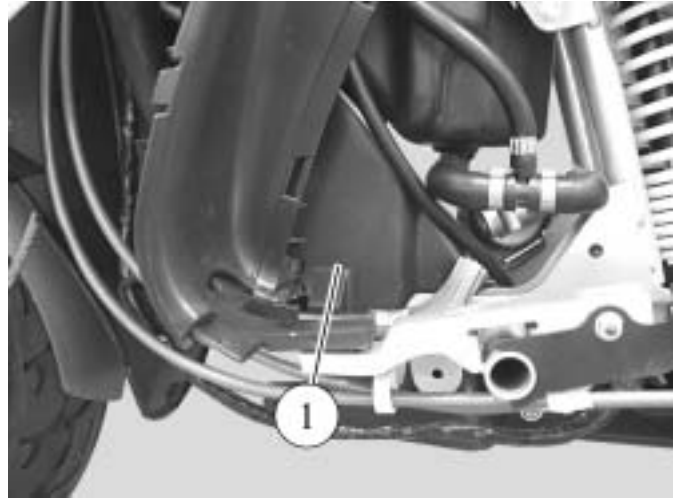

Removal of the braking limiter (50 cc)

- Remove the footboards (4 screws)
- Remove the tunnels (4 screws)
- Remove the bottom panels (7 bis)
- Remove the limiter fixing bolts (1)
- Disconnect and remove the limiter

Note: The braking system should be bled each time the limiter is worked on



Removal of the saddle strut (50 and 125 cc)

- Remove the storage compartment (see procedure 2)
- Remove the saddle strut lower mount (1)
- Remove the saddle strut

Note: Note the position of the saddle strut on the storage compartment

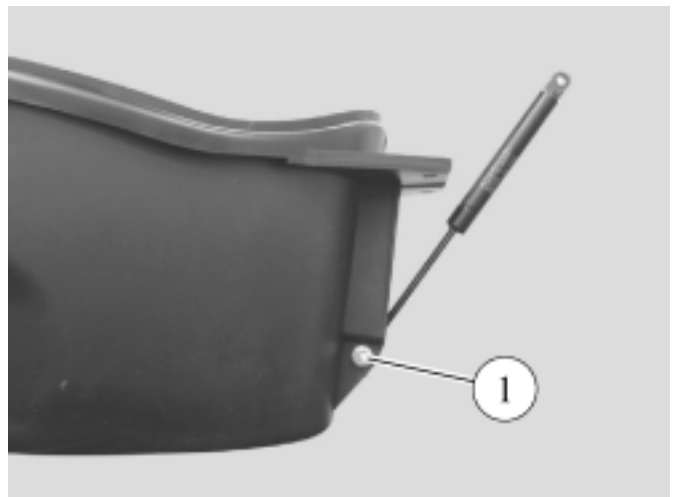

WORKING ON THE ENGINE WITHOUT REMOVING THE ENGINE

WORKING ON THE ENGINE WITHOUT REMOVING THE ENGINE (50 cc)

Removal of the inlet coupling and valves

- Remove the transmission cover strip (1 screw)
- Remove the air filter housing (2 screws)
- Disconnect the throttle cable (1) from the throttle unit
- Disconnect the throttle unit (2)

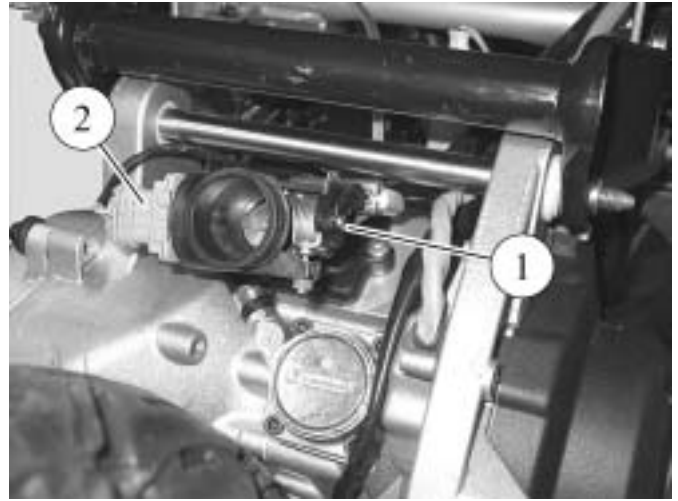

- Remove the inlet coupling 2 fixing bolts
- Remove the inlet coupling and the throttle unit (3)
- Remove the clip from the throttle unit
- Remove the inlet coupling
- Remove the valves and paper gasket (4)

Reassembly: Re-assemble in the reverse order to dismantling

Check: Using the diagnostic tool, check for fault codes, clear them if necessary

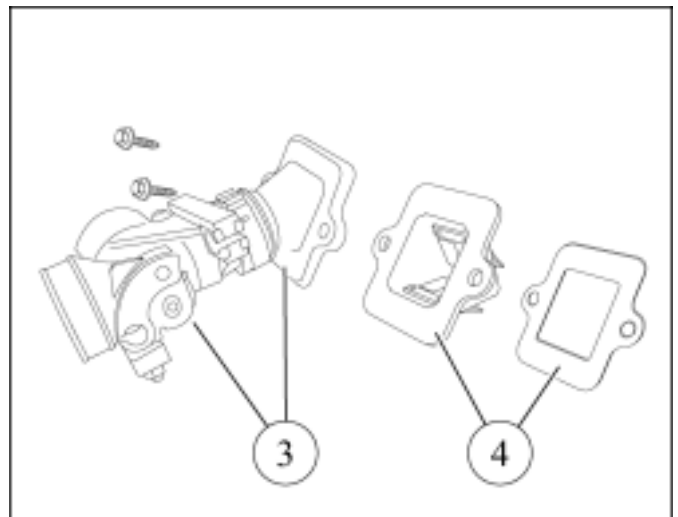

WORKING ON THE ENGINE WITHOUT REMOVING THE ENGINE

To remove the cylinder head Procedure 5

- Remove the footboards (4 screws)
- Remove the tunnels (4 screws)
- Remove the bottom panels (7 bis)
- Disconnect the lower pump from the coolant pump to drain the cooling system
- Disconnect the coolant pipes from the cylinder head and cylinder
- Remove the injection manifold (1) (2 bolts)

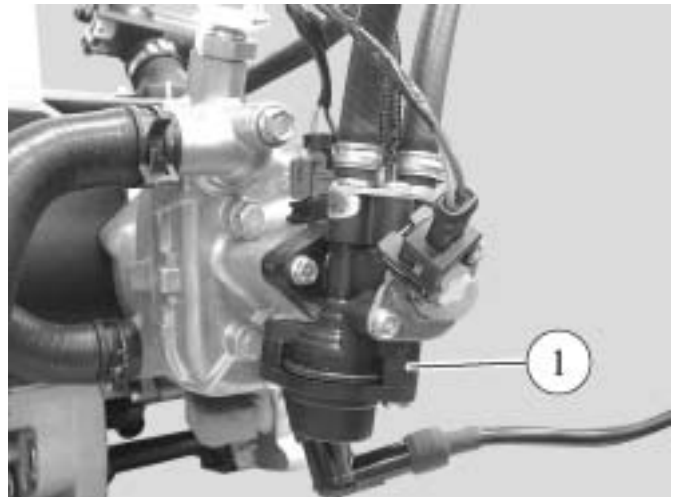

- Disconnect the air injector (2), the temperature sensor and suppressor
- Remove the spark plug
- Working diagonally a few turns at a time, slacken the cylinder head/cylinder assembly fixing bolts
- Remove the 4 bolts
- Remove the cylinder head and the O-ring

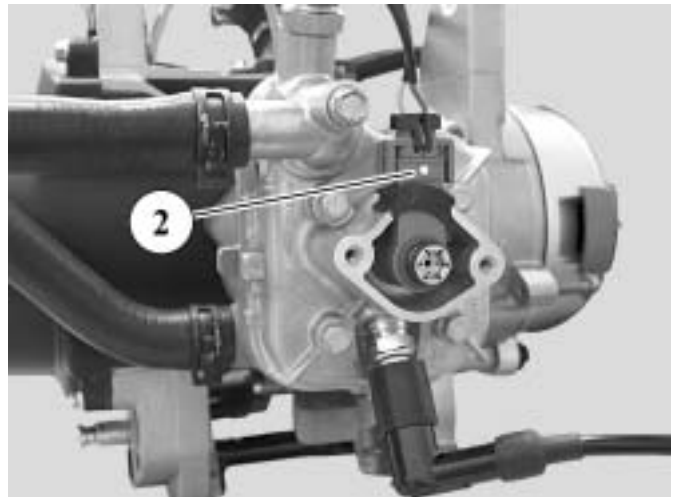

Note: Make sure to block the cylinder in the engine casing in order to avoid damage to the base gasket

Do not remove the air injector if this is not necessary

Removal of the cylinder / piston

- Remove the storage compartment (see procedure 2)
- Remove the exhaust
- Remove the cylinder head (see procedure 4)
- Remove the cylinder and the bottom seal
- Remove the piston

Note: When refitting the cylinder, we recommend locking the piston using the fork part number 756575 in order to facilitate assembly



WORKING ON THE ENGINE WITHOUT REMOVING THE ENGINE

Removal of the temperature sensor

- Remove the storage compartment (see procedure 2)
- Disconnect the temperature sensor (1)
- Remove the sensor

Note: Refit a sensor quickly to prevent loss of coolant



Removal of the air compressor

- Remove the transmission cover strip (1 screw)
- Remove the air filter housing (2 screws)
- Remove the compressor (1) 4 bolts
- Remove the compressor with its hose

- Remove the clip from the pipe (2)
- Remove the compressor

Note: On refitting, fit the compressor with its 2 centring studs and a new lightly greased O-ring. Tighten the 4 fixing bolts working diagonally a few turns at a time

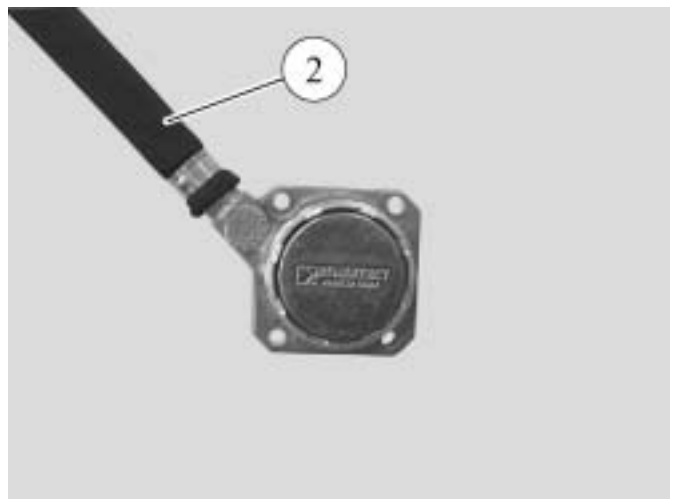

**SPECIAL WORK AND PROCEDURES
WITHOUT REMOVING THE ENGINE**

Procedure for reducing the fuel circuit pressure

Procedure 6 (50 cc)

Important: Wash the power unit

- Remove the footboards (4 screws)
- Remove the tunnels (4 screws)
- Remove the bottom panels (7 bis)
- Disconnect the fuel injector (1)
- Remove the 2 bolts from the injection manifold (2)
- Remove the injection manifold without disconnecting the feed pipes

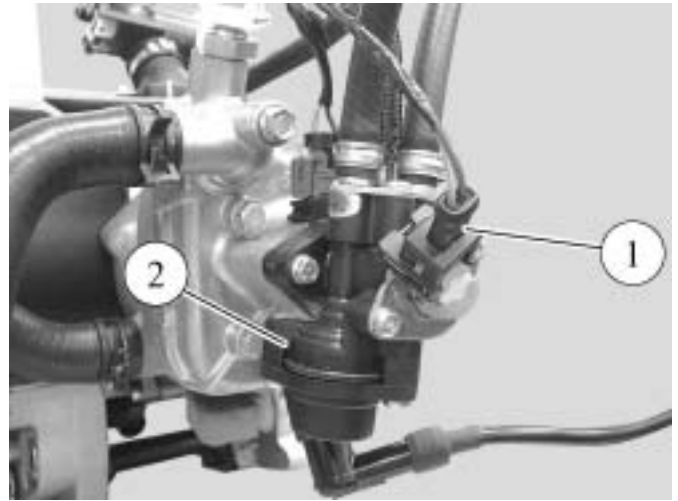

- Connect the fuel injector power supply harness tool P/N 756017 to the fuel injector and the battery
- Put the manifold into a container to recover the fuel
- Operate the tool contactor 5 times for 5 seconds with a 5 second pause between each operation, in order to lower the pressure in the injection manifold supply pipe

Note: Secure the injection manifold in the container, the pressurised jet of fuel may be dangerous for the skin, do not expose the hands to the jet of fuel when opening the injector

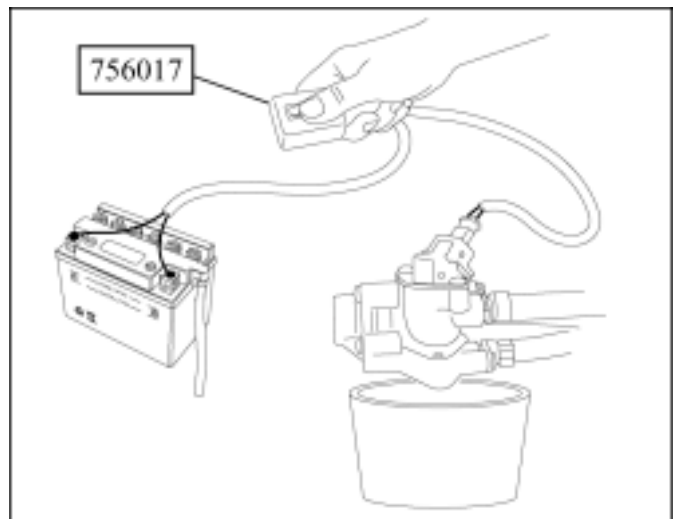

Procedure for bleeding the fuel circuit

Procedure 7 (50 and 125 cc)

- Operate the fuel pump by turning the key to the ignition position (turning on the ignition operates the fuel pump for 3 seconds)
- Carry out this operation twice

SPECIAL WORK AND PROCEDURES WITHOUT REMOVING THE ENGINE

Removal of the injection manifold (50 cc)

Important: Wash the power unit

- Carry out the procedure used to lower the pressure in the fuel system (see instruction 6)
- Remove the clips from the 3 hoses (each time these clips are removed they must be changed for new genuine parts)
- Disconnect the 2 fuel pipes (1)
- Disconnect the air pipe (2) from the compressor
- Remove the injection manifold (3)

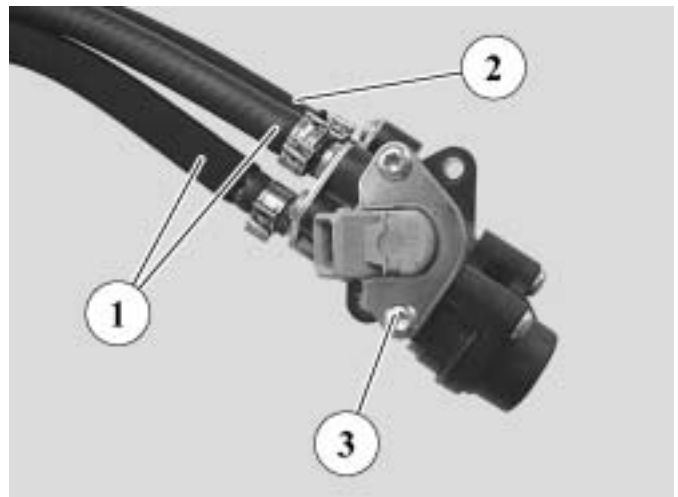

- Remove the O-ring (4) from under the injection manifold (the O-ring must be renewed each time it is removed)

Reassembly: Proceed in reverse order to disassembly and bleed the fuel system (see instruction 7)

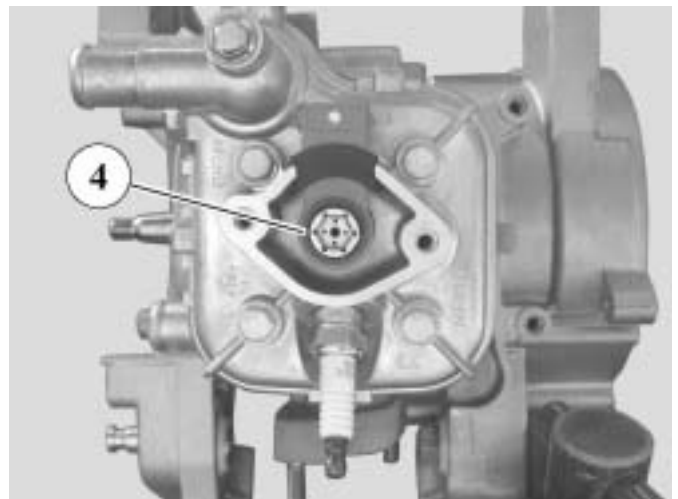

Removal of the air injector (50 cc)

- Remove the cylinder head (see procedure 5)
- Drift out the air injector (1) with drift part number 755989
- Remove the O-ring from under the air injector (the O-ring must be renewed each time it is removed)

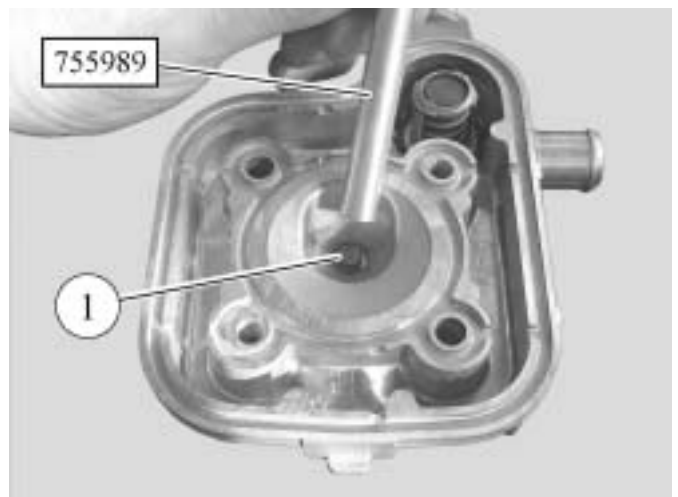

SPECIAL WORK AND PROCEDURES WITHOUT REMOVING THE ENGINE

Important: Put the injector in the holder tool P/N 755986 until ready for refitting

Note: The injector may only be removed for a short instant from its housing in the cylinder head, as the air injector has a Teflon seal which expands if it is not held compressed

Reassembly: Re-assemble in the reverse order to dismantling

Check: Using the diagnostic tool, check for fault codes, clear them if necessary

Removal of the thermostat (50 cc)

- Remove the cylinder head (see procedure 5)
- Remove the circlip (1) from the thermostat (2)
- Remove the thermostat

When refitting, make sure the thermostat (2) circlip (1) is correctly fitted, as shown

Note: The thermostat circlip must be changed each time it is removed

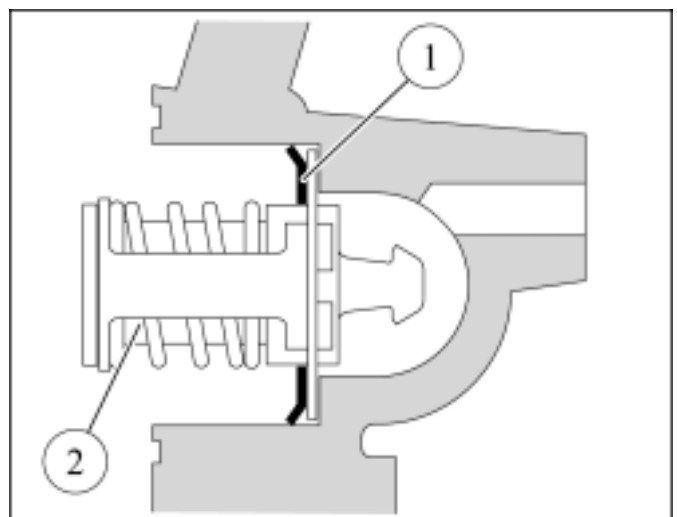
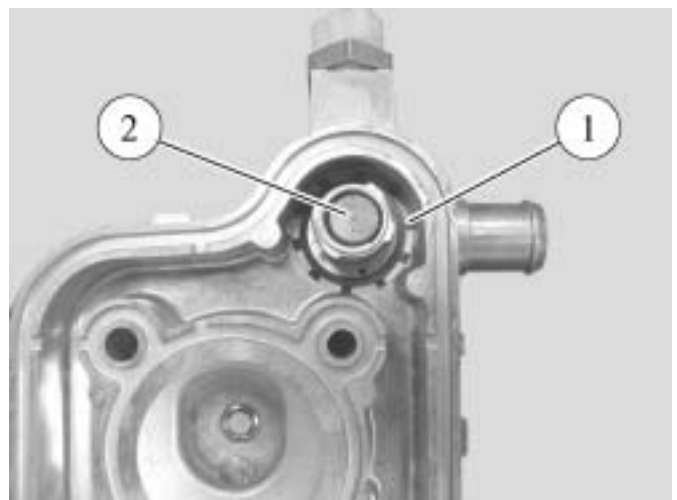

SPECIAL WORK AND PROCEDURES WITHOUT REMOVING THE ENGINE

Removal of the ECU (50 and 125 cc)

- Remove the storage compartment (see procedure 2)
- Remove the ignition key
- Remove the ECU two fixing nuts
- Remove and disconnect the ECU (1)

Important: If the ECU is changed, the throttle unit must be initialised with the diagnostic tool (refer to diagnostic tool user documentation for the injection engine)

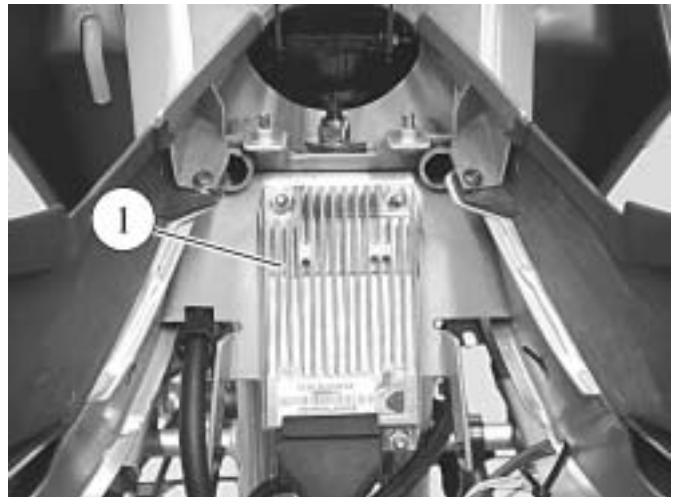

Removal of the throttle unit (50 cc)

- Remove the transmission cover strip (1 screw)
- Remove the air filter housing (2 screws)
- Disconnect the throttle cable (1) from the throttle unit
- Disconnect the throttle unit (2)
- Remove the inlet coupling 2 fixing bolts
- Remove the inlet coupling and the throttle unit
- Remove the clip from the throttle unit
- Remove the throttle unit

Important: If the throttle unit is changed it must be initialised with the diagnostic tool (refer to the diagnostic tool user documentation for the injection engine)

Check: Using the diagnostic tool, check for fault codes, clear them if necessary

Reassembly: Proceed in reverse order to disassembly ensuring:

- the throttle unit positioning pin (A) is properly located in its housing (B) on the inlet coupling
- the throttle cable is properly tensioned
- the throttle unit is properly positioned on the air filter box

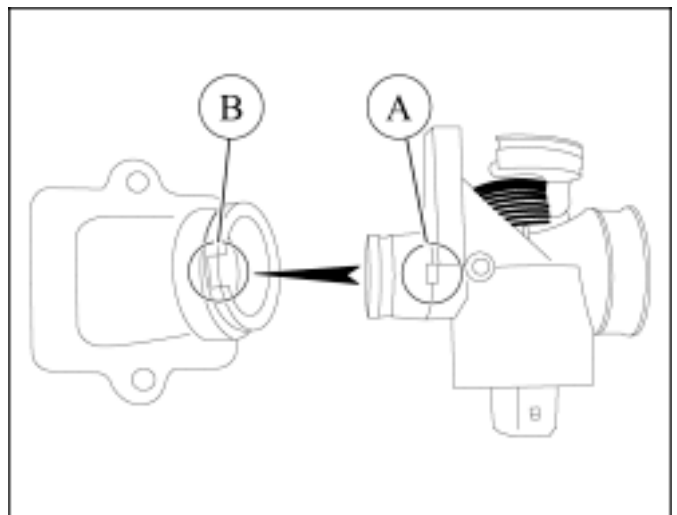

SPECIAL WORK AND PROCEDURES WITHOUT REMOVING THE ENGINE

Removal of the oil pump (50 cc)

- Remove the storage compartment (see procedure 2)
- Disconnect the engine casing separate lubrication pipe
- Disconnect the oil pump (1)
- Remove the oil pump fixing bolt
- Disconnect the oil inlet pipe (2) from the pump
- Remove the oil pump

Important: Using the diagnostic tool bleed the oil pump (refer to the diagnostic tool user documentation for the injection engine)

Check: Using the diagnostic tool, check for fault codes, clear them if necessary

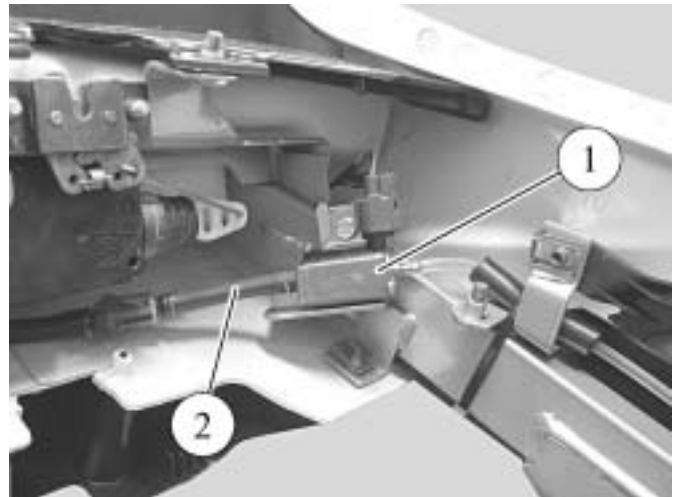

Removal of the fuel gauge (50 cc)

- Remove the footboards (2 screws each)
- Remove the tunnels (3 screws each)
- Carry out the procedure used to lower the pressure in the fuel system (see instruction 6)
- Disconnect the fuel gauge (1)
- Remove the fuel pump (2) from its mounting
- Clamp the fuel inlet hose with the hose clamp part number 755996
- Disconnect the fuel inlet and outlet hoses (3)
- Remove the fuel pump

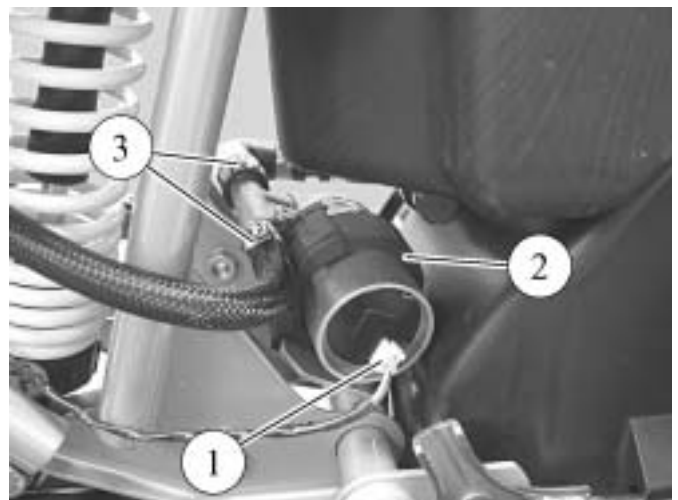

ELECTRICITY

ELECTRICITY

Removal of the instrument cluster (50 and 125 cc)

- Remove the front upper legshield (3 screws)
- Remove the screen (depending on version)
- Remove the handlebar front cover (6 bolts)
- Remove the handlebar rear cover and instrument cluster (1) assembly (3 bolts)
- Disconnect the instrument cluster (2)
- Remove the instrument cluster (4 bolts)

Note: When refitting, carefully connect the harness to the instrument cluster, with the rubber cover on the connector and correctly position the harness securing clip (A)

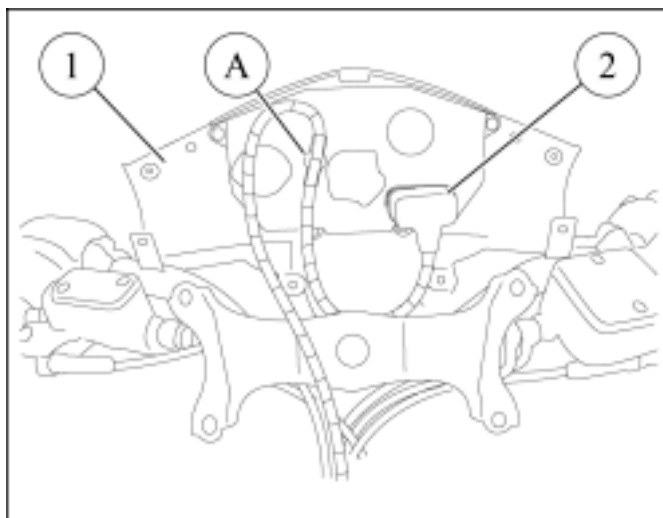

Removal of the voltage regulator and saddle actuator (50 and 125 cc)

- Remove the storage compartment (see procedure 2)
- Remove the regulator (1) or the saddle actuator (2)

Note: When refitting the voltage regulator carefully connect the connector and its cover before fitting to the frame

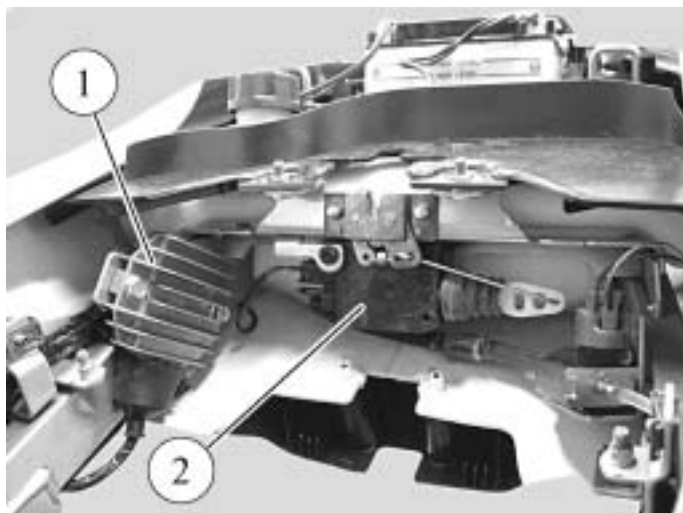

Removal of the battery cover, battery, fuses (50 and 125 cc)

- Remove the passenger seat (2 bolts)
- Remove the battery cover (1) (1 bolt)
- Remove the battery and/or change the fuses



ELECTRICITY

Removal of the starter motor and/or lighting relay (50 and 125 cc) and/or the fuel pump and/or ABS/PBS system relay (125 cc)

- Remove the rear cover assembly (see procedure 4)
- Remove the relay concerned
 - lighting relay (1) (50 and 125 cc) and fuel pump relay (125 cc)
 - starter motor relay (2) (50 cc) (on the 125 cc the relay is on the other side)
 - ABS/PBS system relay (depending on version)



Removal of the high tension coil (50 and 125 cc)

- Remove the left footboard (2 screws)
- Remove the left tunnel (2 screws)
- Remove the 2 coil fixing bolts (1)
- Disconnect the coil (2) and the spark plug lead
- Remove the high tension coil

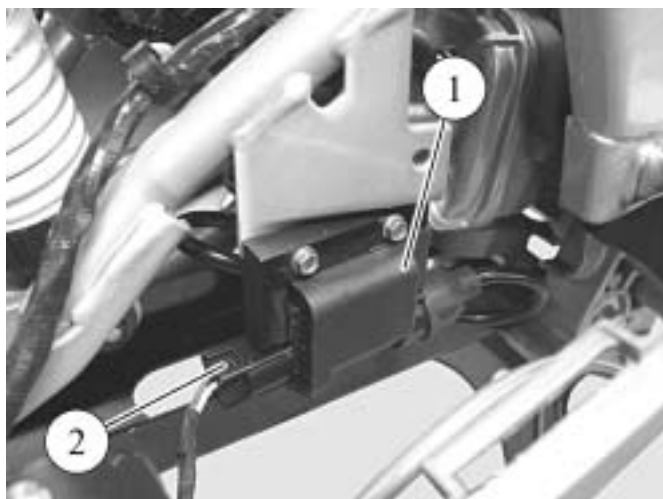

Removal of the horn, immobiliser module (50 and 125 cc)

- Remove the front legshield assembly (see procedure 1)
- On the 50 cc, the horn is mounted to the right of the radiator support bracket
- On the 125 cc, the horn is mounted on the front legshield support bracket

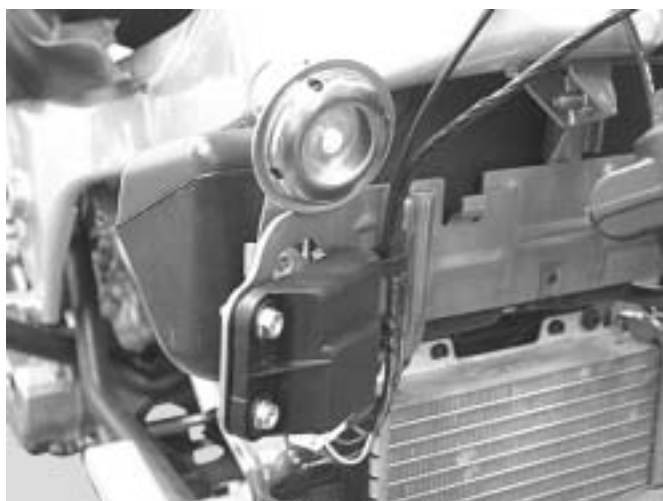

Note: If the immobiliser module is changed, the key programming procedure must be carried out

ELECTRICITY

Removal of the transponder antenna (50 and 125 cc)

- Remove the front lower legshields (see procedure 1)
- Remove the rear shield panel (see procedure 3)
- Unclip the antenna (1) from the steering lock
- Disconnect the antenna from the transponder module
- Remove the antenna from the transponder

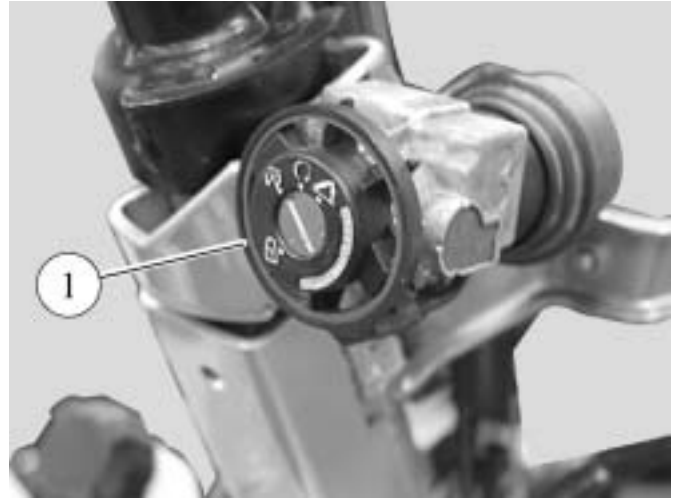

Removal of the starter motor (50 cc)

- Remove the storage compartment (see procedure 2)
- Disconnect the starter motor
- Remove the starter motor (1) 2 bolts
- Remove the starter motor

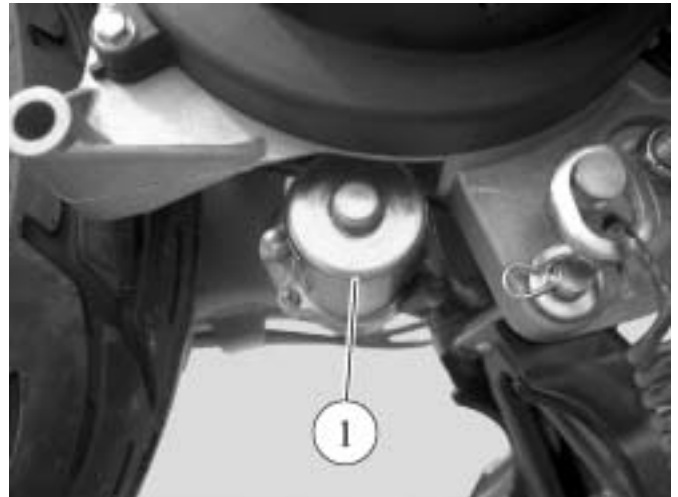

ENGINE REMOVAL

Removal of the 50 cc engine

Important: Wash the power unit

- Remove the storage compartment
- Remove the passenger seat
- Remove the battery cover
- Disconnect the battery
- Remove the 2 footboards
- Remove the 2 tunnels
- Remove the lower panel
- Remove the transmission cover strip
- Remove the air filter unit
- Drain off the cooling system at the water pump hoses
- Disconnect:
 - the magneto
 - the starter motor
 - the throttle unit
 - the air injector
 - the suppressor
 - the temperature sensor
 - the throttle cable
 - the crankcase separate lubricating oil inlet

- Remove the injection manifold without disconnecting the fuel supply pipes (see relevant chapter), however disconnect the compressor air pipe
- Pull clear the injection manifold and protect it from foreign matter with a clean rag
- Remove the exhaust
- Slacken off the wheel hub nut
- Remove the wheel
- Remove the 2 brake calipers but do not disconnect them
- Remove the disc/hub assembly
- Suspend the rear of the machine
- Remove the linkrod to swingarm fixing pin
- Remove the engine mounting upper pin
- Remove the engine / stand / linkrod assembly
- Remove the linkrod
- Remove the stand
- Remove the engine upper mount bush

125 cc SPECIFIC MISCELLANEOUS WORK

Removal of the idle valve

- Disconnect the battery
- Disconnect the fuel injector (1)
- Disconnect the idle valve (2)
- Disconnect the idle valve two hoses (3)
- Remove the idle valve (4)

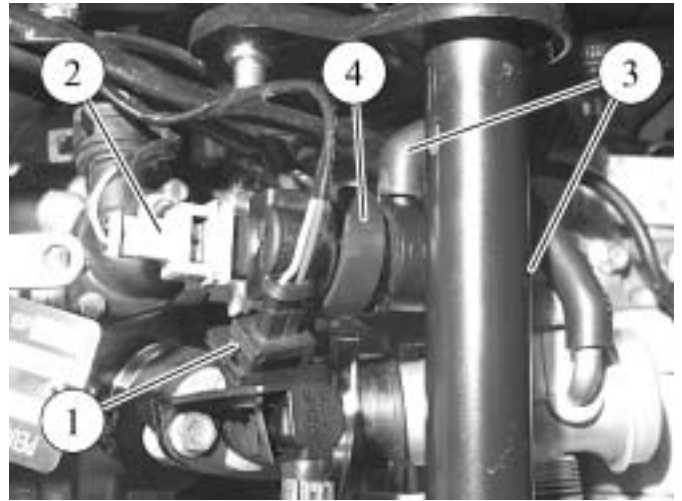

Removal of the thermostat

- Remove the storage compartment (see procedure 2)
- Disconnect the battery
- Disconnect the idle valve (1)
- Disconnect the engine casing cooling system inlet pipe in order to drain the system
- Remove the top (2) from the thermostat (2 screws) without disconnecting the hose
- Remove the thermostat

Note: After refitting, bleed the engine circuit hot and check the coolant level in the header tank (Peugeot approved coolant)

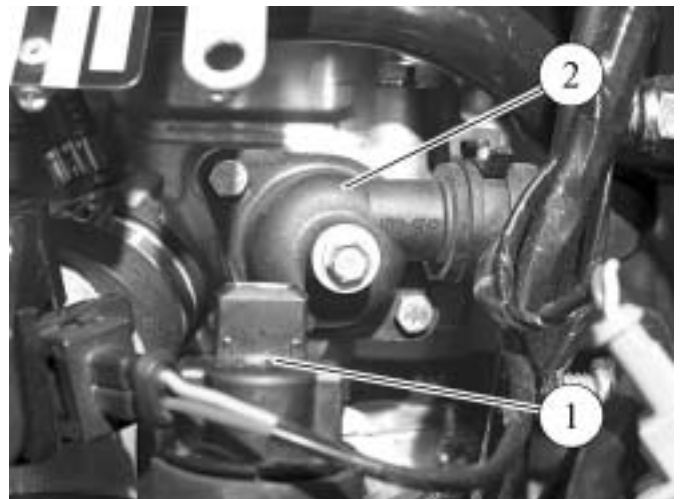

Removal of the engine temperature sensor

- Remove the storage compartment (see procedure 2)
- Disconnect the battery
- Disconnect the fuel injector and the idle valve
- Disconnect the temperature sensor (1)
- Disconnect the engine casing cooling system inlet pipe in order to drain the system
- Remove the sensor (1) and its seal

Note: The seal must be changed each time it is removed

After refitting, bleed the engine circuit hot and check the coolant level in the header tank



125 cc SPECIFIC MISCELLANEOUS WORK

Removal of the fuel injector

- Remove the storage compartment (see procedure 2)
- Disconnect the battery
- Disconnect the fuel injector (1)
- Disconnect the fuel feed hose (2) (1 clip, to be changed each time it is removed)
- Remove the fuel injector (3) (1 bolt)

Inspection: Connect the diagnostic tool and check there are no fault codes, erase them if necessary

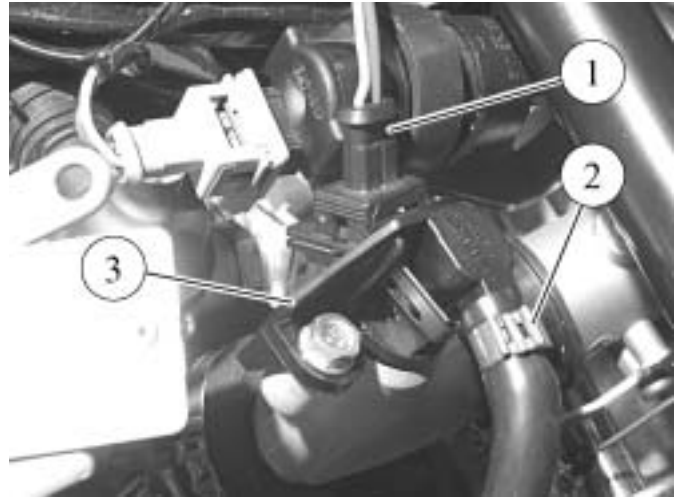

Removal of the oil pressure switch

- Remove the exhaust elbow (1) (2 bolts and 2 nuts)
- Disconnect the pressure switch (2)
- Remove the cylinder to casing fixing bolt (3)
- Remove the oil pressure switch (2) and its seal

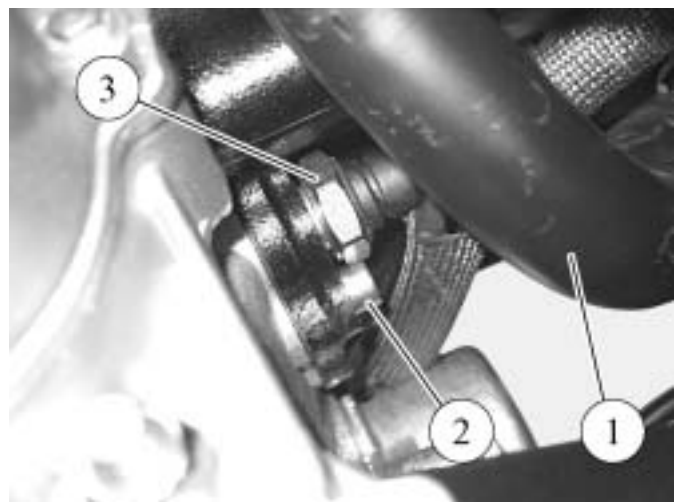

Removal of the throttle unit

- Remove the storage compartment (see procedure 2)
- Disconnect the battery
- Disconnect the atmospheric pressure sensor (1)
- Disconnect the oil vapour return pipe (2)
- Remove the air filter housing (3) (2 bolts)

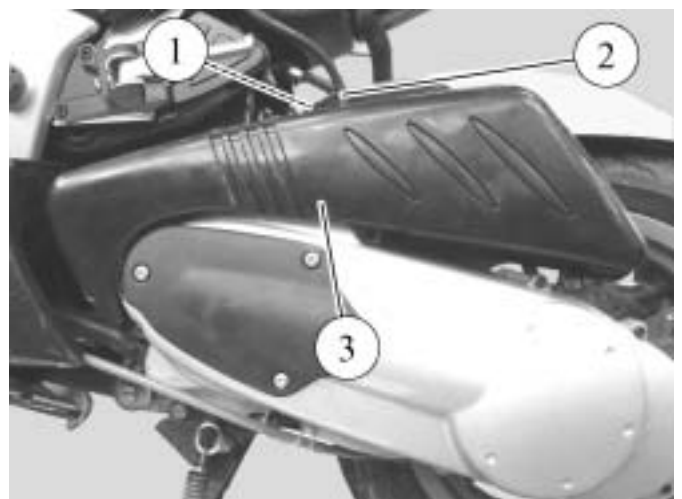

125 cc SPECIFIC MISCELLANEOUS WORK

- Disconnect the throttle unit and the idle valve
- Remove the throttle cable
- Remove the throttle unit with the idle valve (1 clip, to be changed each time it is removed)

Important: If the throttle unit is changed it must be initialised with the diagnostic tool (refer to the diagnostic tool user documentation for the injection engine)



Reassembly: Proceed in reverse order to disassembly ensuring:

- the throttle unit positioning pin (A) is properly located in its housing (B) on the inlet coupling
- the throttle cable is properly tensioned
- the throttle unit is properly positioned on the air filter box

Inspection: Connect the diagnostic tool and check there are no fault codes, erase them if necessary

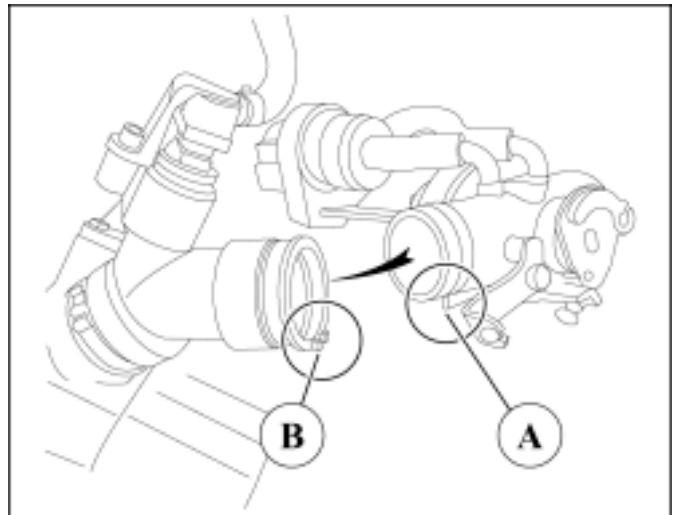

125 cc SPECIFIC MISCELLANEOUS WORK

Removal of the fuel pump / of the fuel gauge

- Remove the storage compartment (see procedure 2)
- Remove the tank cover panel (5 screws)
- Remove the saddle pivot bracket (1) (2 nuts)
- Remove the ignition key
- Disconnect the fuel gauge (2)
- Disconnect the fuel gauge (3)

Note: Put a rag over the fuel pipe to catch any fuel splashes

- Disconnect the fuel feed pipe (4) and the regulator vacuum pipe (5)

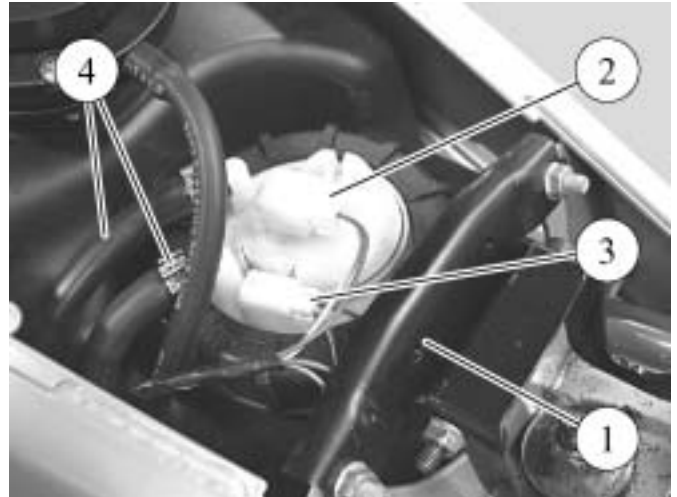

- Remove the fuel gauge with its seal using the gauge wrench part number 756715 (and press on the tool in order to squash the rubber seal and unscrew one quarter of a turn)

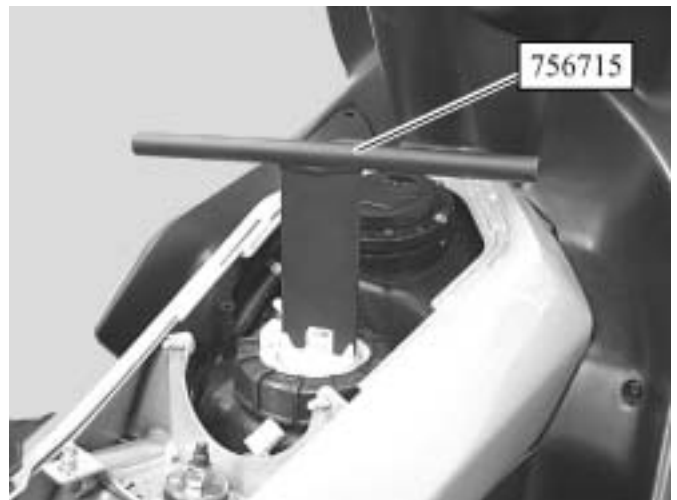

- Unscrew and remove the fuel pump assembly with its seal using tool P/N 756716

Note: None of the components, fuel pump, pressure regulator and strainer are removable. It is only possible to clean the outside of the strainer.

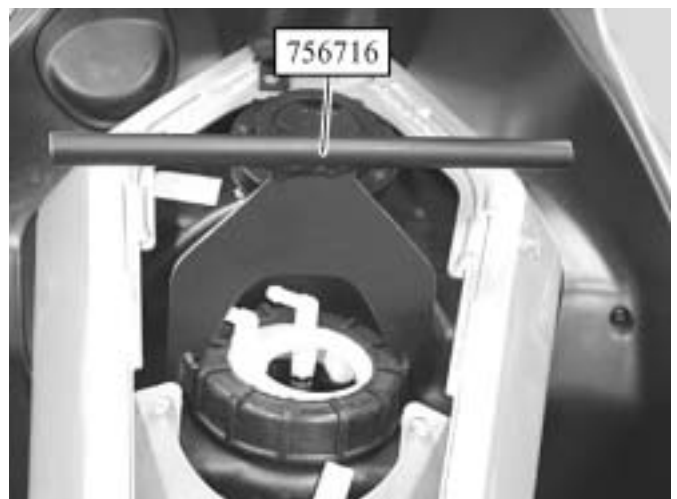

125 cc SPECIFIC MISCELLANEOUS WORK

Reassembly: Re-assemble in the reverse order to dismantling

- Tighten the fuel pump using the plug wrench P/N 756716 in order to position the arrow (A) between the marks (B) on the tank
- Fit the fuel gauge with a new seal using the gauge wrench P/N 756715

Inspection: Connect the diagnostic tool and check there are no fault codes, erase them if necessary

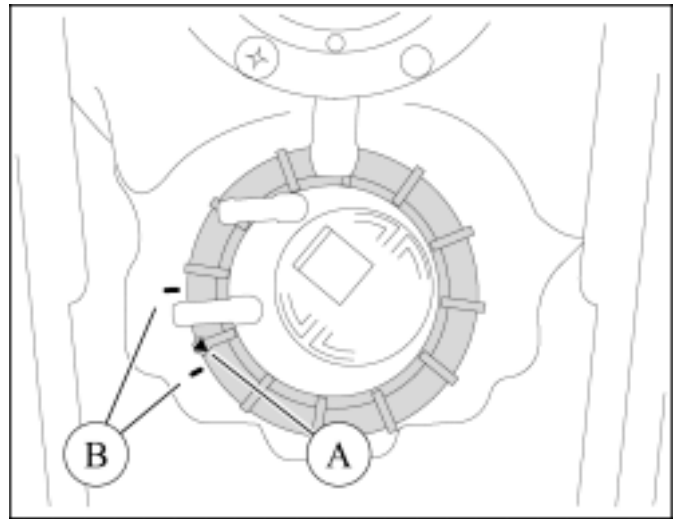

Removal of the starter motor

- Disconnect the atmospheric pressure sensor
- Disconnect the oil vapour return hose
- Remove the air filter housing (2 screws)
- Disconnect the battery
- Disconnect the starter motor (1)
- Remove the starter motor (2) (2 bolts)

Note: One of the starter motor fixing bolts is used for the battery engine earth (green wire)

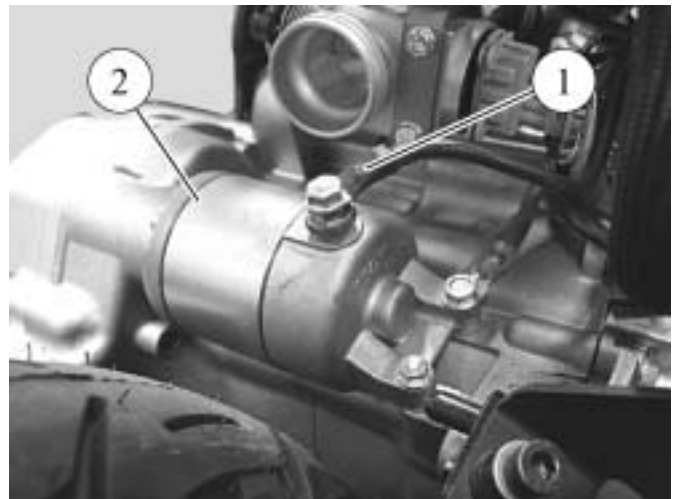

125 cc SPECIFIC MISCELLANEOUS WORK

Removal of the rear brake pads or caliper

- Remove the pad 2 fixing pins
- Remove the caliper 2 fixing bolts
- Pull the caliper onto the disc to release the pads (1)
- Remove the brake pads

Note: After removing the pads, the caliper may be removed from the brake disc. If the caliper is to be changed, the hydraulic control must be slackened off before removal

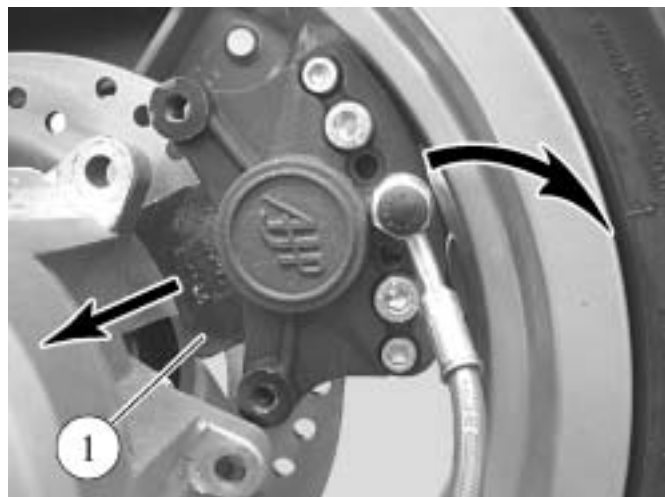

Removal of the suspension arm

- Remove the exhaust (3 bolts and 2 bolts nuts)
- Remove the wheel spindle nut and the 2 washers
- Remove the suspension arm (1) to casing 2 fixing bolts
- Remove the suspension arm



Note: For re-assembly proceed in reverse order to removal as shown in the diagram

1. Suspension arm
2. Wheel spindle nut
3. Plain washer
4. Bearing flanges
5. Bush

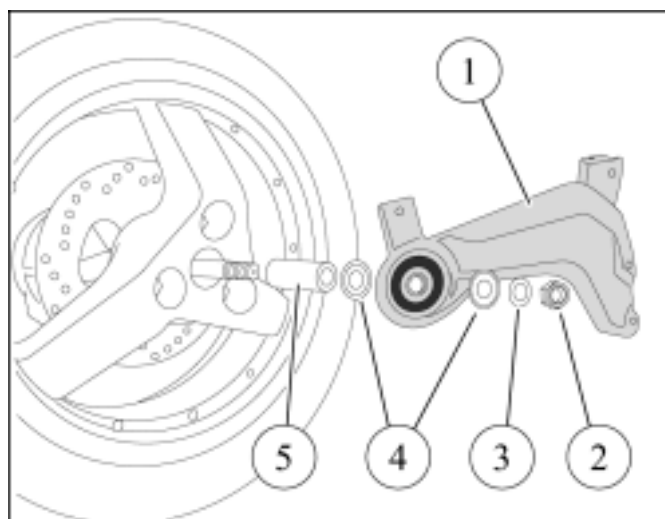

Removal of the engine mounting twin linkrod

- Remove the storage compartment (see procedure 2)
- Remove the left-hand footboard and tunnel
- Disconnect the battery
- Disconnect the oil vapour return pipe to the air filter
- Disconnect the atmospheric pressure sensor
- Remove the air filter unit
- Disconnect the starter motor, the idle valve and the fuel injector
- Disconnect the magneto harness and engine harness connections
- Slacken off the upper mounts (1) of the engine mounting twin linkrod (2)
- Slacken off and remove the twin linkrod lower securing pin (3)

Note: Suspend the machine or wedge it under the swingarm twin linkrod

- Remove the twin linkrod upper fixing pins

- Remove the twin linkrod and the 2 rubber bump stops (4)

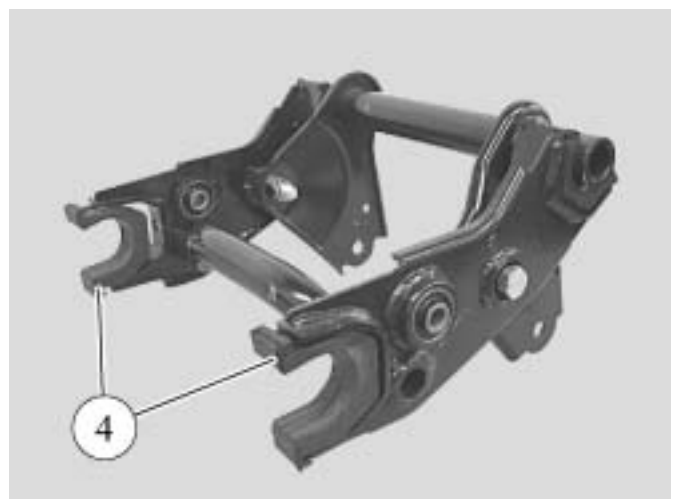
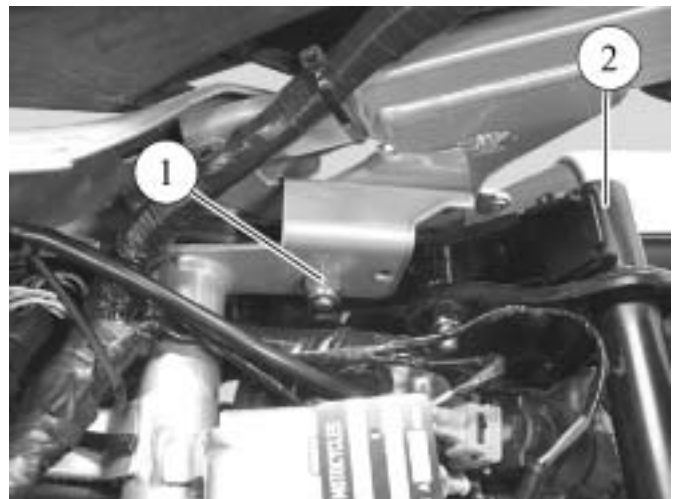

125 cc SPECIFIC MISCELLANEOUS WORK

Method of fitting the engine mounting twin linkrod

- Fit the 2 rubber bump stops (1) to the frame
- Fit the twin linkrod (2) to the frame taking care it lines up with the rubber bump stops

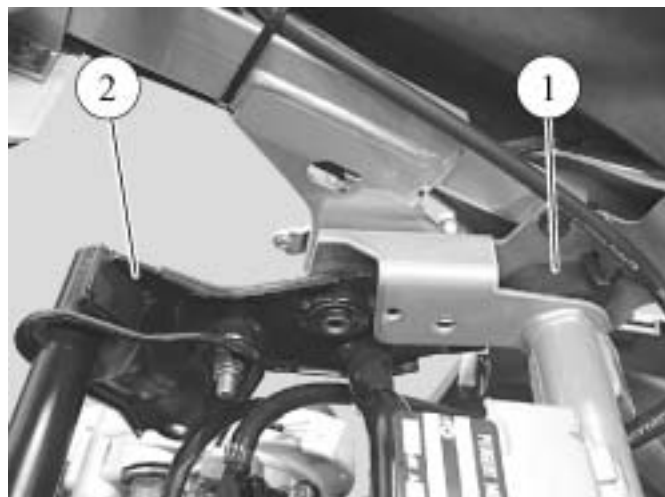

- Fit the twin linkrod upper fixing pins (3)



- Fit the twin linkrod lower fixing pin (4)



125 cc SPECIFIC MISCELLANEOUS WORK

Removal of the motor-driven fan heat switch

- Remove the front lower legshields (see procedure 1)
- Remove the rear shield panel (see procedure 3)
- Remove the fork guard (1) 2 fixing bolts without removing the guard
- Remove the mudguard (2)
- Drain off the coolant
- Disconnect the heat switch (1)
- Remove the heat switch

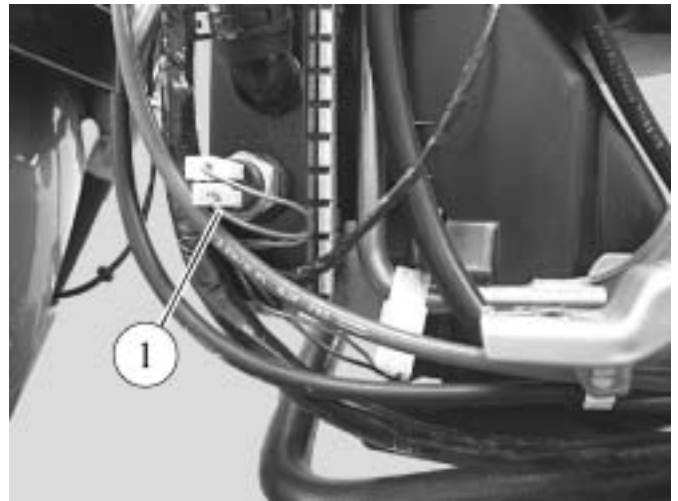

Removal of the motor-driven fan

- Remove the front lower legshields (see procedure 1)
- Remove the rear shield panel (see procedure 3)
- Remove the fork guard (1) 2 fixing bolts without removing the guard
- Remove the mudguard (2)



- Disconnect the fan (3)
- Remove the header tank and the radiator but do not disconnect them
- Remove the fan



125 cc SPECIFIC WORK REQUIRING ENGINE REMOVAL

Removal of the power unit Procedure 8

- Remove the storage compartment
- Remove the left-hand footboard and tunnel
- Disconnect the battery

- Disconnect the oil vapour return pipe to the air filter
- Disconnect the atmospheric pressure sensor
- Remove the air filter unit

- Disconnect the starter motor, the idle valve and the fuel injector
- Disconnect the magneto harness and engine harness connections
- Disconnect the suppressor

- Disconnect the throttle cable from the throttle unit
- Disconnect the injector fuel feed hose
- Disconnect the cylinder head air hose
- Disconnect the oil vapour return hose to the rocker cover

- Disconnect the oil filler pipe

- Remove the pad fixing pins
- Remove the caliper 2 fixing bolts
- Rest the caliper on the disc to remove the pads
- Remove the brake pads
- Remove the caliper from the brake disc
- Remove the hydraulic control from its guides on the engine casing

- Disconnect the engine casing coolant inlet pipe to drain the circuit
- Disconnect the coolant outlet to the thermostat



Note: Suspend or wedge the machine frame before removing the power unit

- Remove the engine 2 pins securing it to the frame linkrod and engine linkrod
- Remove the power unit from the frame

125 cc SPECIFIC WORK REQUIRING ENGINE REMOVAL

Removal of the engine Procedure 9

- Remove the power unit (see procedure 8)
- Remove the complete exhaust system
- Remove the inlet coupling and the throttle unit
- Remove the suspension arm
- Remove the wheel hub assembly
- Remove the stand

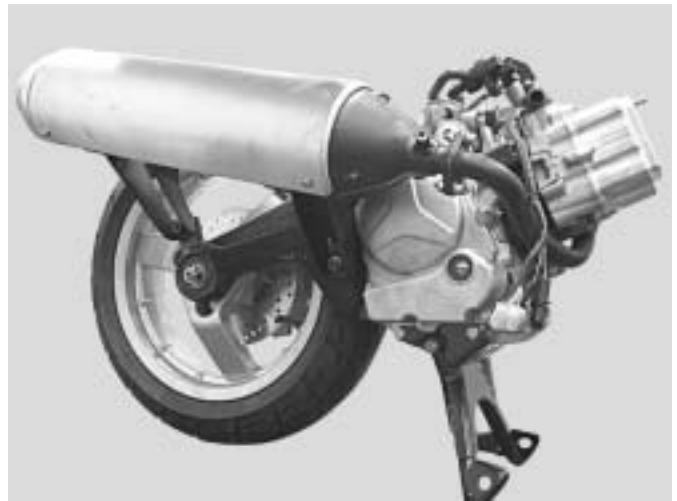

Removal of the rocker cover, setting the rockers, removal of the camshaft, removal of the rockers

- Remove the power unit (see procedure 8) and refer to the FD1 ENGINE workshop manual

Removal of the cylinder head, removal of the cylinder and/or piston, removal of the cylinder head or base gasket, removal of the timing chain, setting the timing

- Remove the power unit (see procedure 8)
- Remove the exhaust and refer to the FD1 ENGINE workshop manual

Removal of the connecting rod and/or LH bearing and/or changing the casings

- Remove the engine (see procedure 9) and refer to the FD1 ENGINE workshop manual





PEUGEOT
Motorcycles

RECOMMENDS



 **UTAC**
CERTIFICATION
SYSTEMES QUALITE
ISO 9001
Certificat n° SQ/766

REF: 756739

For reasons of continuous improvement, Peugeot Motorcycles reserves the right to modify, delete or add any part number quoted
DC/PS/ATR printed in EU 02/2002 (photos non-contractual)

