

moped

KORADO

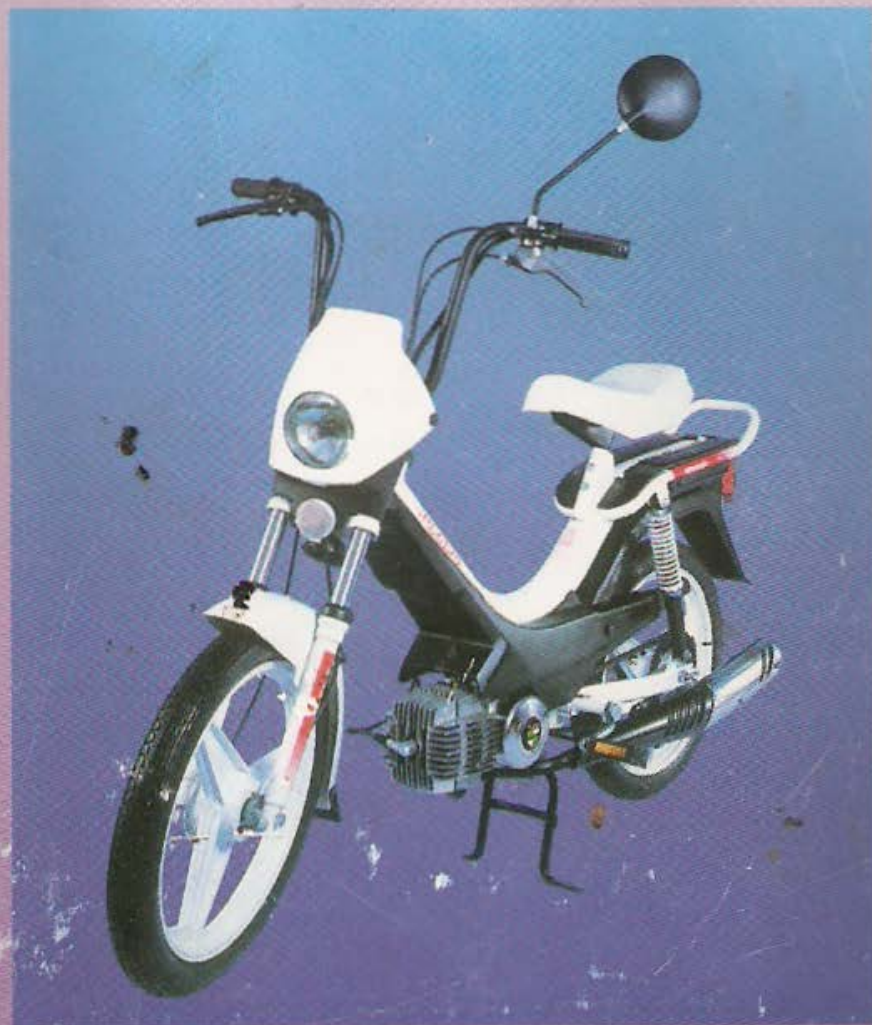

Shell



Owner's Manual

moped

KORADO

Owner's Manual

The moped KORADO is a vehicle used for transport on roads with reinforced surface to bring you to work or to spend free time for leisure and sports.

The vehicle is driven with a reliable PUCH motor which is built under licence and together with easy operation guarantees safe, comfortable and economic driving. It has a massive frame, good ergonomical parameters and a modern design. Among its other advantages belong long life, high performance, economical operation and a reasonable price.

Read this manual before your first driving to learn how to operate the moped and respect recommendations included in this manual. The KORADO moped went through long-time testing and its modern production technology and tradition is a guarantee of its high European quality standard.

We wish you many troublefree and safe kilometers on your new moped.

**PS MOTOR MANET a. s.
Považská Bystrica**

The producer reserves the right to change the text and pictures in this manual.

CONTENT

Main partsi	5
Introduction.....	6
Technical data	7
Control elements	8
Instructions for driving	10
Maintenance and adjustment	12
Maintenance chart	24
Lubrication chart	25
Troubleshooting	26
Electrical equipment diagram	27
Tools and outfit	28
Spare parts	28

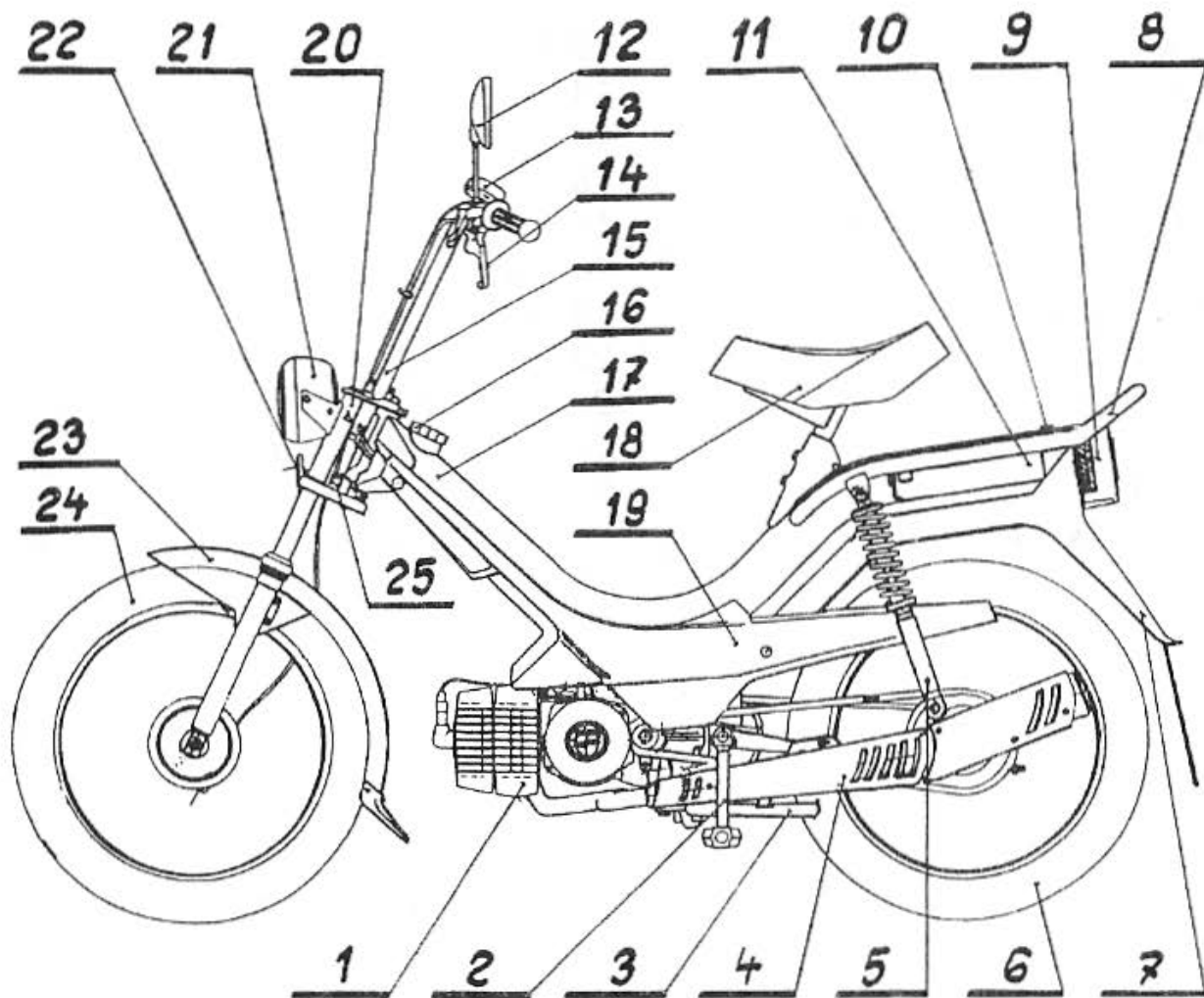

Fig. 1 KORADO Moped - main parts

1. Engine
2. Pedals
3. Stand
4. Exhaust silencer
5. Telescopic rear suspension
6. Rear wheel
7. Rear mudguard
8. Luggage rack
9. Rear light
10. Air-release valve
11. Tool kit
12. Rear-view mirror
13. Bell
14. Control levers
15. Handlebars
16. Filler cap
17. Frame
18. Saddle
19. Side covers
20. Teleskopic front suspension
21. Headlight
22. Front reflecting glass
23. Front mudguard
24. Front wheel
25. Lock

1. Introduction

-Takeover of the motorcycle

Control the outfit for completeness according to the documentation when taking over the motorcycle.

-Control the serial number if it coincides with the documentation- the serial number is located on the upper part of the frame and is readable from the right side of the motor. The motor number need not be identical with the number of the chassis. Get acquainted with the main parts and control elements before your first drive (fig. 1).

-ATTENTION - You have bought a two-stroke engine. It is therefore necessary to mix the main fuel - gasoline with oil in the ratio 1:33 when breaking-in and 1:40 after breaking-in the engine. Use fuel with octane number 95 and oil SHELL-SUPER 2T. When using synthetic oil SHELL SUPER 2TX the mixing ratio is 1:50.

2. Technical data

Engine	Single-cylinder two-stroke air-cooled
Displacement	48.8 cm ³
Bore/stroke	38/43 mm
Maximal output	2 kW / 4500 r.p.m.
Gear box	automatic one-stage
Starting clutch	wet, mechanical
Run-up clutch	wet, mechanical
Primary transmission	by means of gear 1:5.052
Secondary transmission	by means of a roller chain 1:3.000
Bicycle transmission	by means of a roller chain 1:0.785
Front suspension	telescopic fork with shock absorber -stroke 80 mm
Rear suspension	telescope with shock absorber -stroke 60 mm
Brakes	expanding shoe-brakes controlled by levers on handle bars
Brake dimensions	85 x 20 mm
Tyres	2 1/4 x 16"
Inflation pressures - front tyre	2 atp (196 kPa) 30 PSI
- rear tyre	2,5 atp (245 kPa) 36 PSI
Overall weight	145 kg
Moped dry weight	57,5 kg 127 lb
Max. speed	40 km/h

Fuel tank capacity	4 l	
Hill-climbing capacity	14 %	
Noise	72 dB (A)	
Basic fuel consumption	1,7 l/100 km at 27 km/h	
Carburettor	BING 18/14/108	
Power supply	alternator 6 V/20 W	alternator 12 V/40 W
Ignition	flywheel magnet-type contact ignition	flywheel magnet-type contactless ignition
Spark advance	1.2-1.4 mm, gap 0,4 mm	1,2-1,4 mm
Spark plug	BOSCH W 5 AC	BOSCH W 5 AC
Headlamp	6 V/15 W	12 V/15 W
Tail lamp	6 V/5 W	12 V/5 W

3. Control elements (fig. 2)

The following elements are on right side of the handlebar:

- throttle control (1)
- front brake lever (2)
- choke (3)
- engine stop push button (8)

The following elements are on the left side of the handlebar:

- firm grip (4)
- rear brake lever (5)
- starting clutch lever (6)
- lights switch (7)

Apart from these control elements there is a bell (9) and a rear-view mirror (10) on the left side of the handlebars.

The lock is on the left side below the handlebars (25 fig. 1)

The filler cap (16 fig. 1) is on the front part of the frame and the air-release valve (10 fig. 1) on the rear part of the frame.

The fuel cock is in the front part of the right side cover.

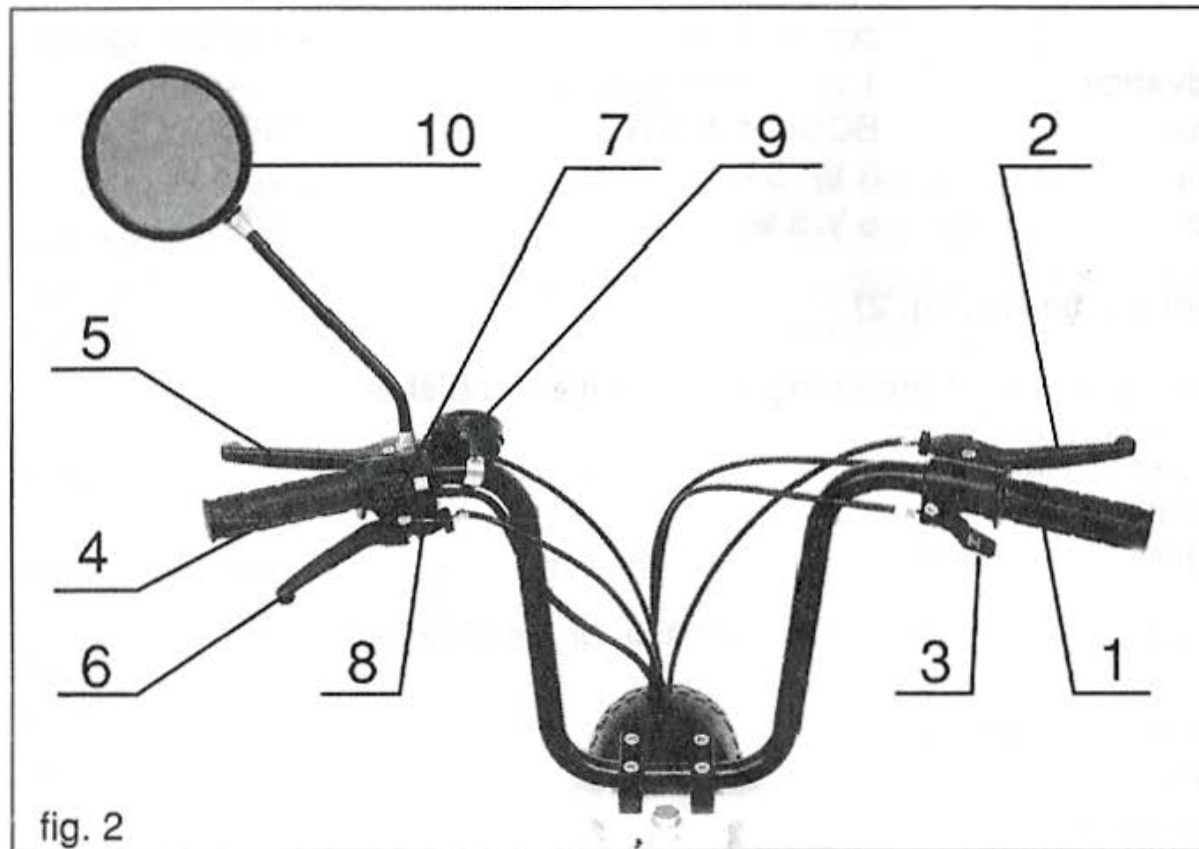

4. Instructions for driving

Fill the tank with the gas-oil mixture before driving as follows:

Unscrew the cap of the tank and release the air-release valve which is in the upper rear part of the frame. Fill the tank up to the mark which is a wire sieve in the filler neck. Close the air-release valve after refilling by tightening the screw and put on the filler cap.

ATTENTION! The air-release valve can not be loosened after filling the tank. it could cause fuel leaking through the ventilation hole of the filler cap. **If it is not possible to fill the gas-oil mixture automatically at the petrol station mix the fuel in a vessel before refilling the tank.**

Check the following before driving:

- correct function of the brakes
- inflation pressure
- function of lights
- tightening of the chain

Drive with the headlight on according to the traffic regulations.

Starting the moped

You can start the moped in two ways: a) on the stand

b) with moving vehicle by pedaling

a)

Starting with stationary vehicle is more common:

Turn the fuel cock in the position „OPEN“ or „RESERVE“. Place the vehicle on the central stand so that it stands on its front wheel (the rear wheel is in the air). Approach the vehicle from the left side and put the pedal in such a position that it is with the road at an angle of 60° in the front position. Press the lever of the starting clutch 6 fig. 2 with the left hand and the choke 3 fig. 2 with the right hand. Put your foot on the pedal and push it quickly downward. Release the lever of the starting clutch when the pedal is in the bottom position. The engine starts running. Keep the choke depressed for a short time which is necessary to warm up the engine. Do not use the choke with warm engine. If the start is not successful repeat it.

ATTENTION!

Do not use the choke to switch off the running engine.

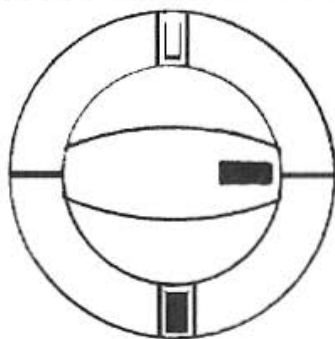

CLOSED

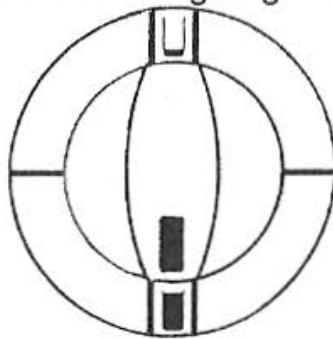

OPEN

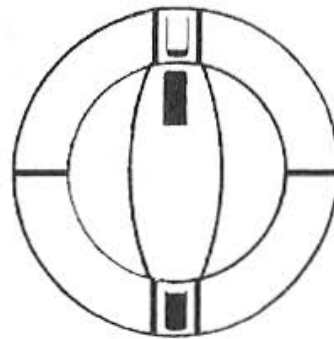

RESERVE

b)

Starting by pedaling

Put the fuel cock into the position „OPEN“ or „RESERVE“. Use the pedals to start moving. When you reach a sufficient speed press the clutch lever with the left hand and the choke with the thumb of your right hand at the same time. Release both levers after the engine starts. Turn the twist grip to continue driving. By full turning of the twistgrip the throttle of the carburettor opens fully and the vehicle reaches its maximum speed.

Do not start with moving vehicle if the weather conditions are bad (wet road, ice etc.).

Stopping the engine

Lower the rotations of the engine, apply brakes and stop the vehicle.

The engine is idling. Press the engine cut-off 8 fig. 2 (red push button on the right side of the handlebar) and the engine stops.

Breaking-in a new engine

Prepare the fuel mixture by mixing gas and oil in the ratio 1:40. Drive the first 500 km with a maximal speed of 35 km/h.

5. Maintenance and adjustment

For cleaning the varnished and chromium plated vehicle parts use only water and detergents. After washing, wipe these parts dry. Do not use kerosene and other solvents when cleaning parts of plastics or rubber because they have detrimental effect on such parts.

Take a short ride after washing the vehicle and dry the brakes by repeated short breaking.

Exhaust silencer - it is almost not contaminated if you use the correct gas-oil mixture.

You do not have to clean it after the first 5000 km. It is necessary to remove the carbon deposits if the gas-oil ratio was wrong and after several years of driving.

Adjustment of brakes

The front and rear brakes have two adjustment elements. Use the adjustment elements at the end of the bowdrens fig 4a, b for rough adjustment and the elements on the control levers fig. 3a, b for fine adjustment. Set the adjusting screw 1 fig. 3a, b on the handlebars into medium screwed position before rough adjustment.

Procedure: Put the brake lock into such a position that the jaws are fully open. Loosen it slightly and fix it in this position by means of the adjustment element (screw, nut). Press the brake lever.

If the play is too small: the lock of the brake has to be loosened more by means of the adjustment screw on the handlebars.

If the play is too big: Find the right position by „fine“ turning of the adjustment element on the lever so that the knurled screw determines the right position and fix it with the plastic nut.

The brakes are correctly adjusted when the levers have a play of about 10 mm from the grip after being depressed. The brakes must be adjusted again when this distance decreases to about 2 mm due to the wear of the brake lining.

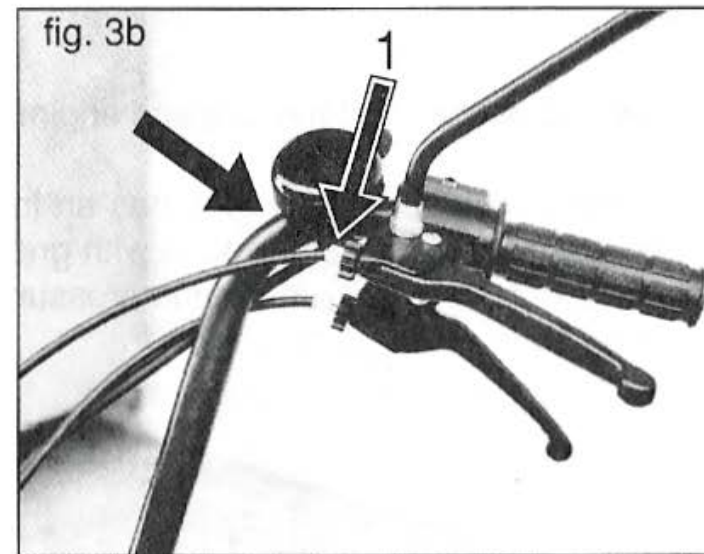
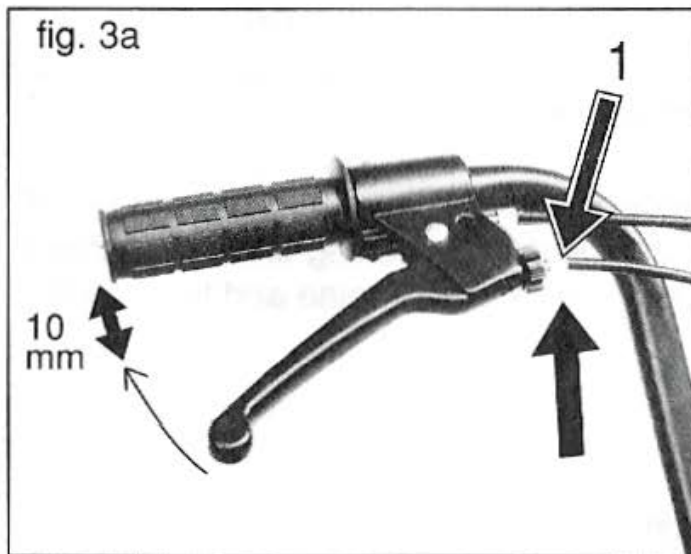

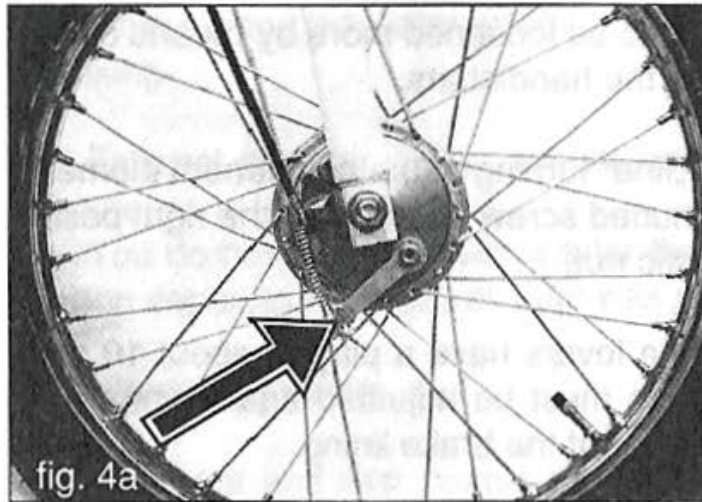

fig. 4a

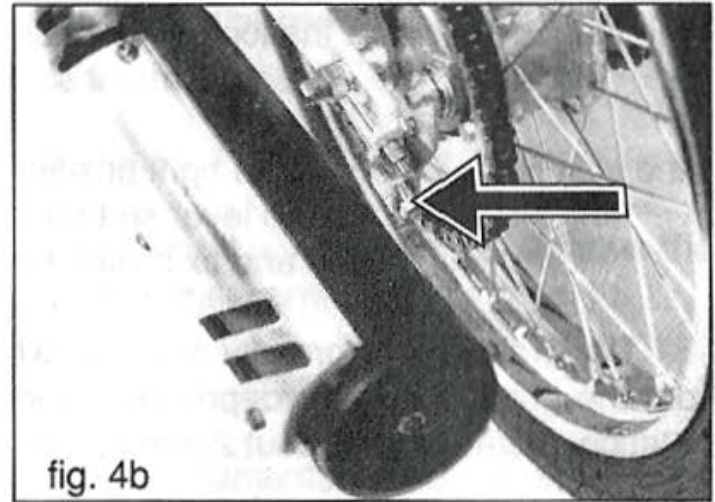

fig. 4b

Tightening of chains of the foot and engine transmission

Correct tightening of chains has an influence on the quality of driving and life of parts. It should be therefore done with great care. Optimal tightening allows the chain to sag about 10 mm under thumb pressure. Both chains - the engine and foot chain - must be done at the same time.

Procedure:

Loosen the axle of the rear wheel and tighten the engine chain and foot chain fig. 5b by means of the tighteners 2. If the tightening arm of the foot chain pulley has a sufficient play of about $15-30^\circ$, tighten the rear wheel axle. If the tightening pulley of the foot chain has a small or no possibility of tightening, loosen the nut of the pin and turn the pin into such a position which makes the movement of the tightening pulley possible.

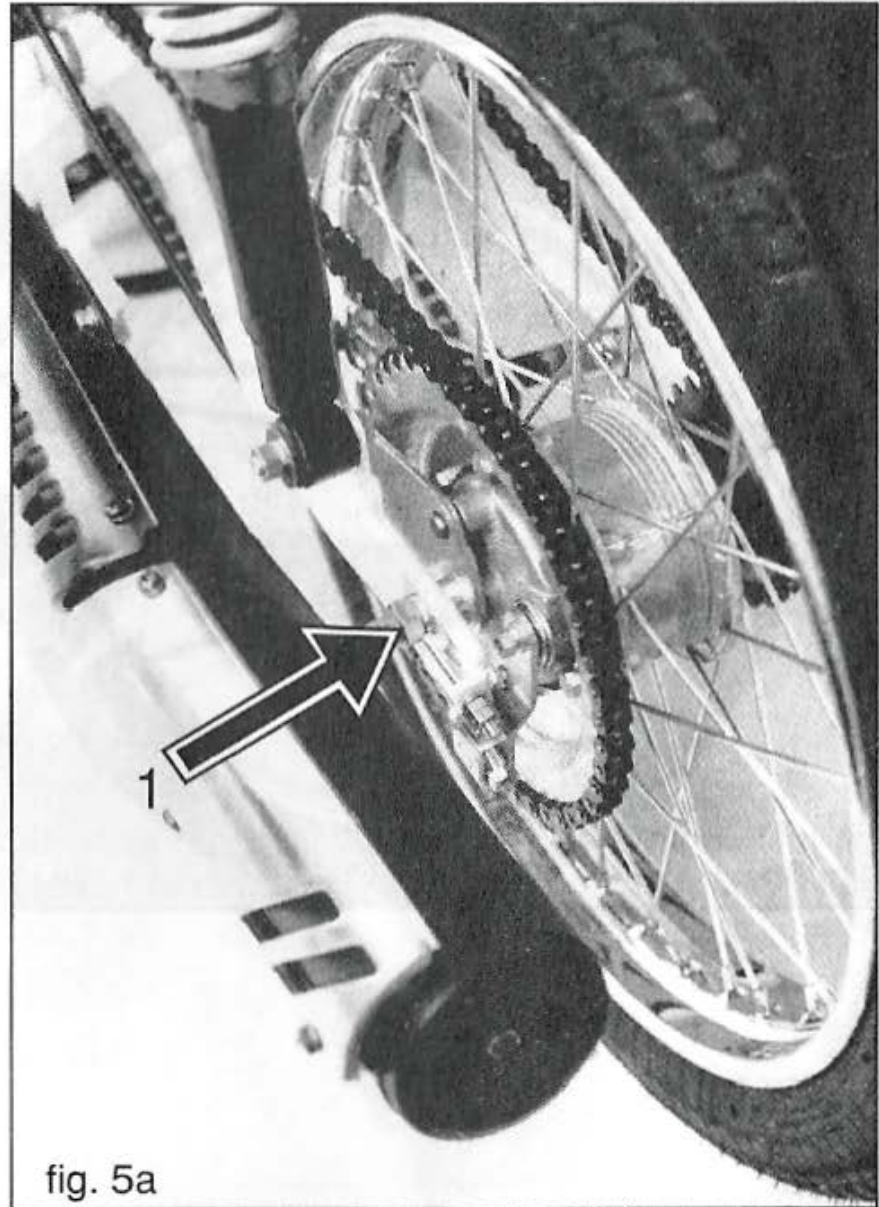
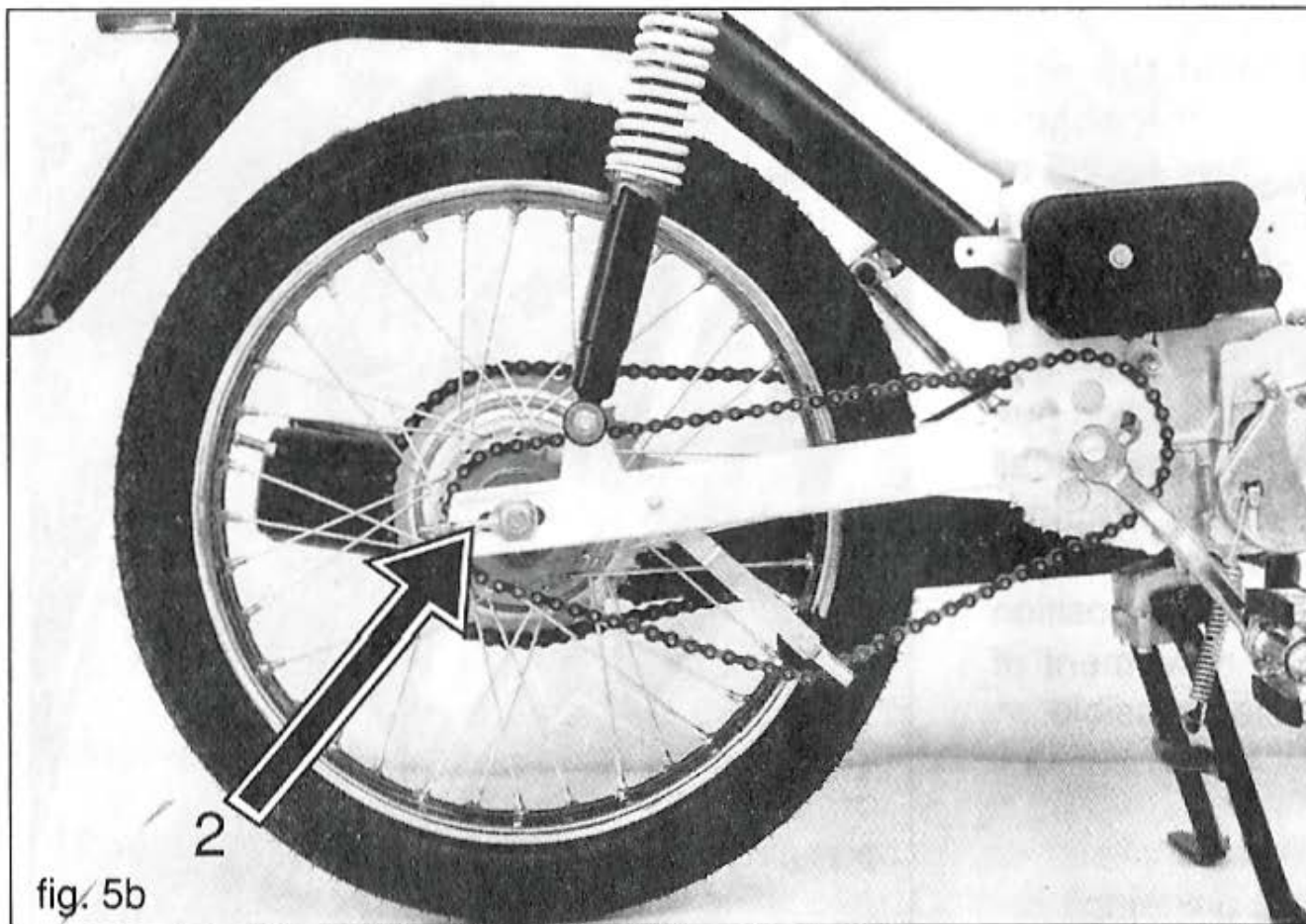

fig. 5a



Adjustment of the carburettor

The BING carburettor is adjusted by the manufacturer to give optimal parameters. It is therefore undesirable to change the setting because it could influence its optimal setting.

If the carburettor is out of order it is recommended to have it repaired in an authorized repair shop.

Oil change in gear-box:

Recommended oil is SHELL DONAX TA. Oil filling is done by producer for life cycle of vehicle. In case of any other repairs where oil must be changed, contact your dealer.

Adjustment of the ignition

Optimal adjustment of the ignition ensures optimal output of the engine. The adjustment has to be carried out with utmost care and accuracy and should be done in an authorized repair shop

Adjustment of the starting clutch

The starting clutch is adjusted by the manufacturer. After a certain time when the friction material of the clutch wears out the clutch starts to slide and it has to be readjusted.

In order to readjust the clutch we must decrease the „free movement“ of the starting clutch lever. The free movement should be 20 mm and we can set it by partially unscrewing the screw of the clutch bowden 1 fig. 6 and its securing with the plastic nut 2 fig. 6.

The second adjustment place is the bowden support in the lower part of the frame (fig. 7).

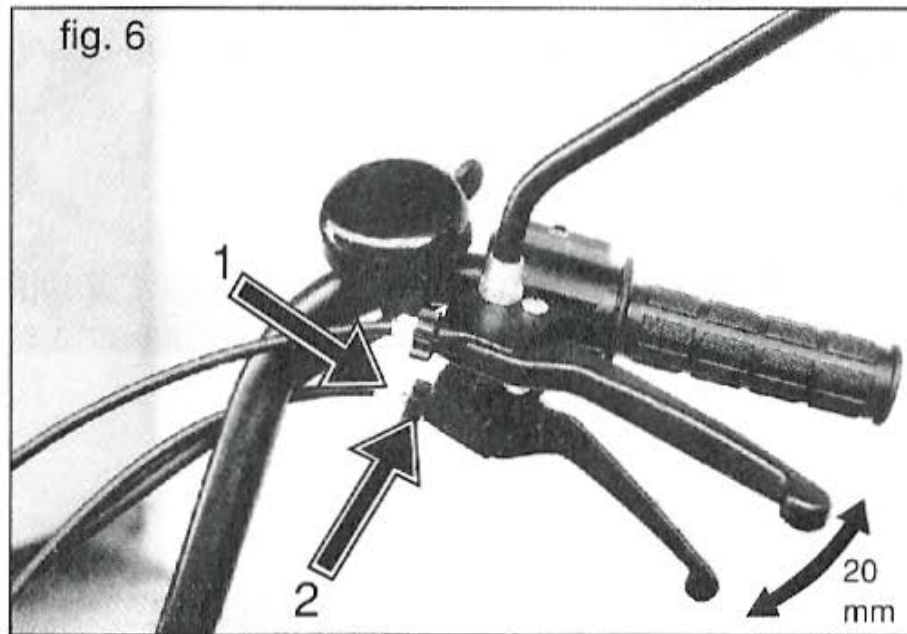

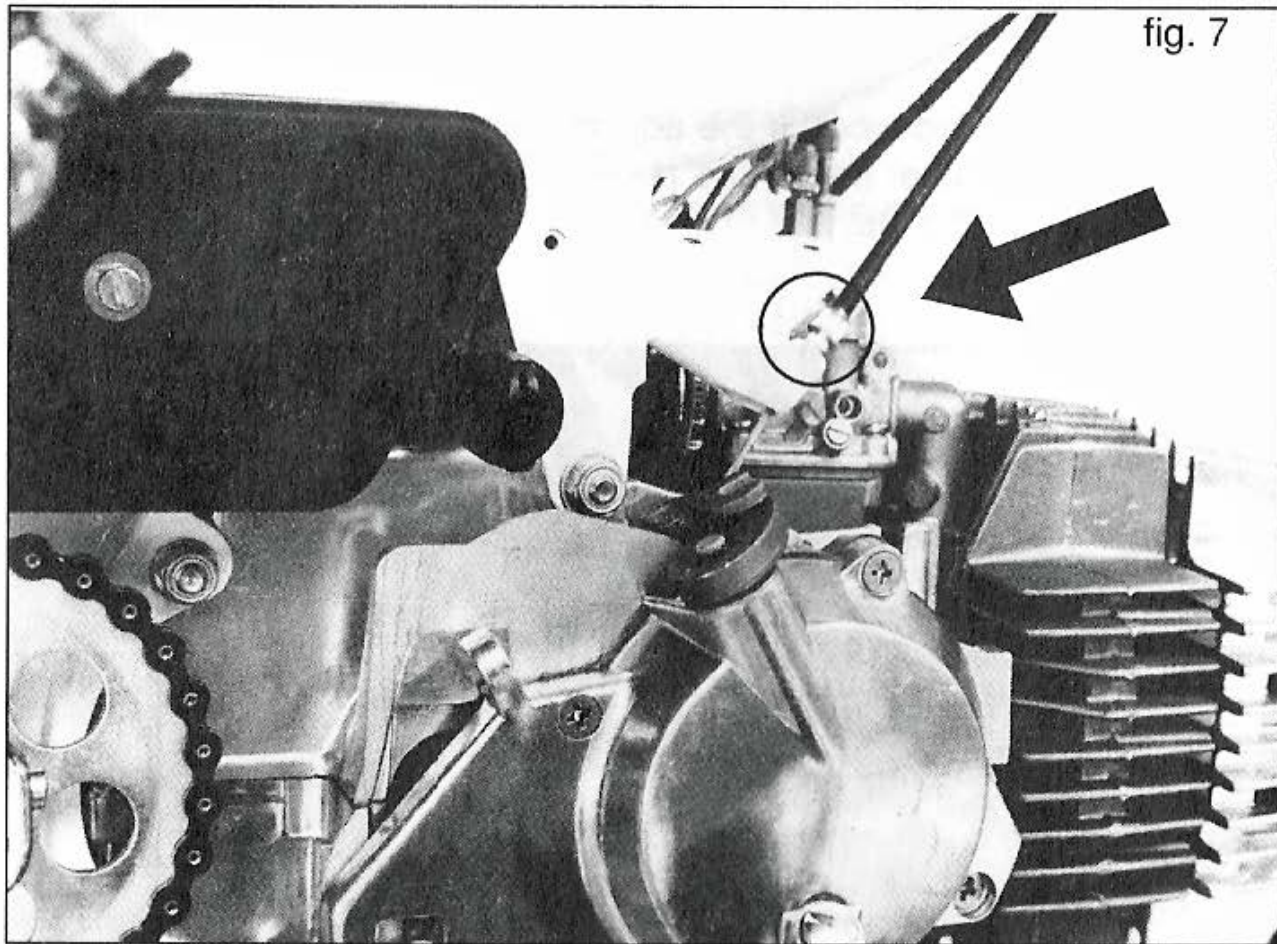

Adjustment of the headlight

The headlight is set by the producer. If the adjustment is not correct for any reason and the headlight dazzles other riders and pedestrians it must be readjusted by means of an eccentric element (fig. 8).

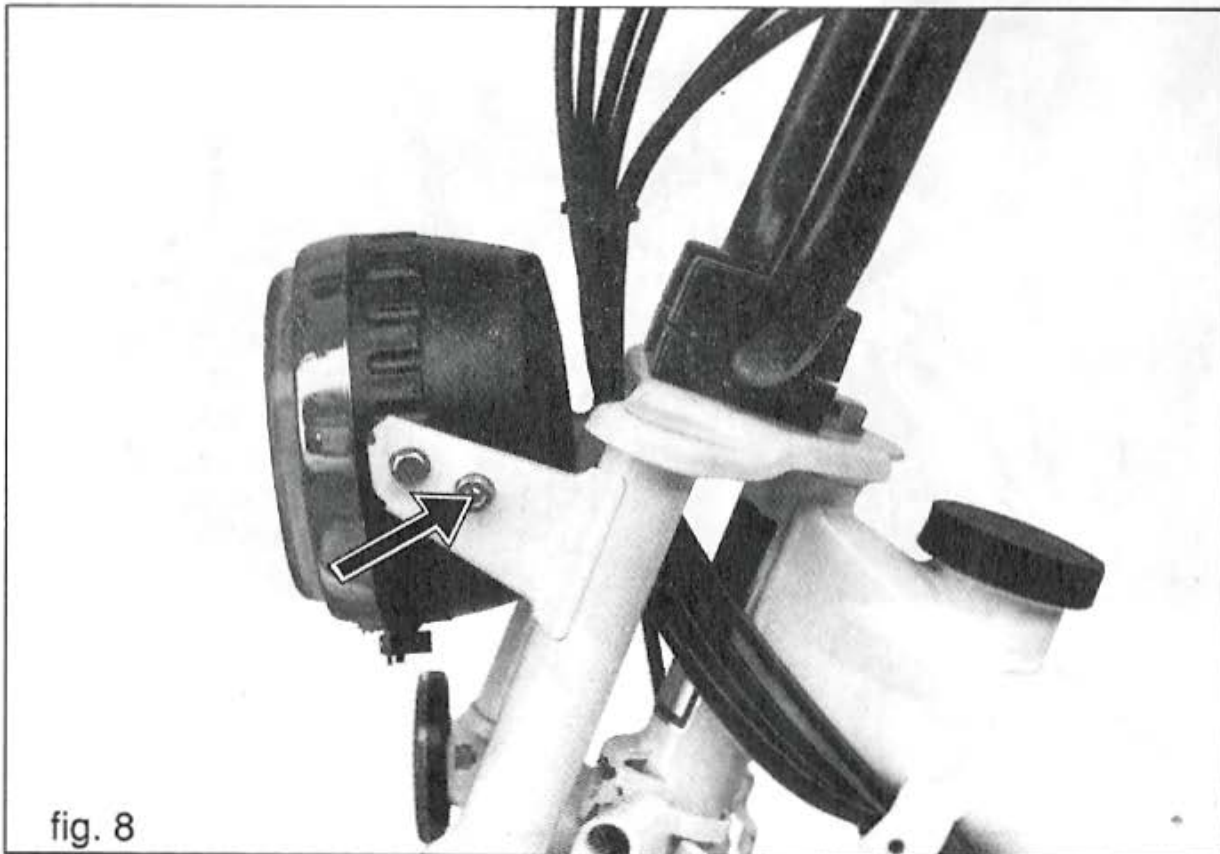

Ajustment of the handlebars

If the driver is big in stature it is possible to adjust the handlebars by loosening the bridges 4 using the screw with a hexagonal.

ATTENTION! Retighten the screws with sufficient torque (about 18 Nm).

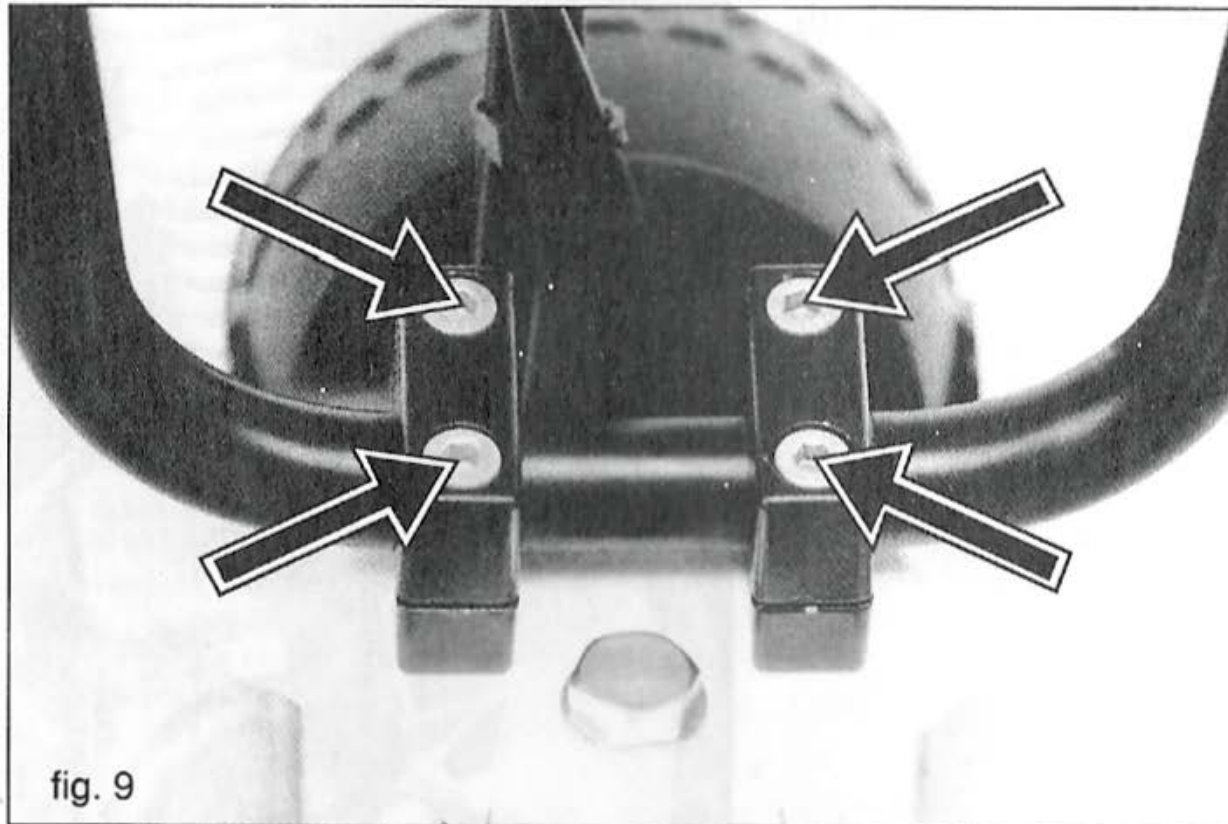

Front a rear telescopic suspension

The rear telescopes are adjustable. The can be adjusted according to the load by means of the adjustment element (1) in the direction of the arrow (see fig. 10).

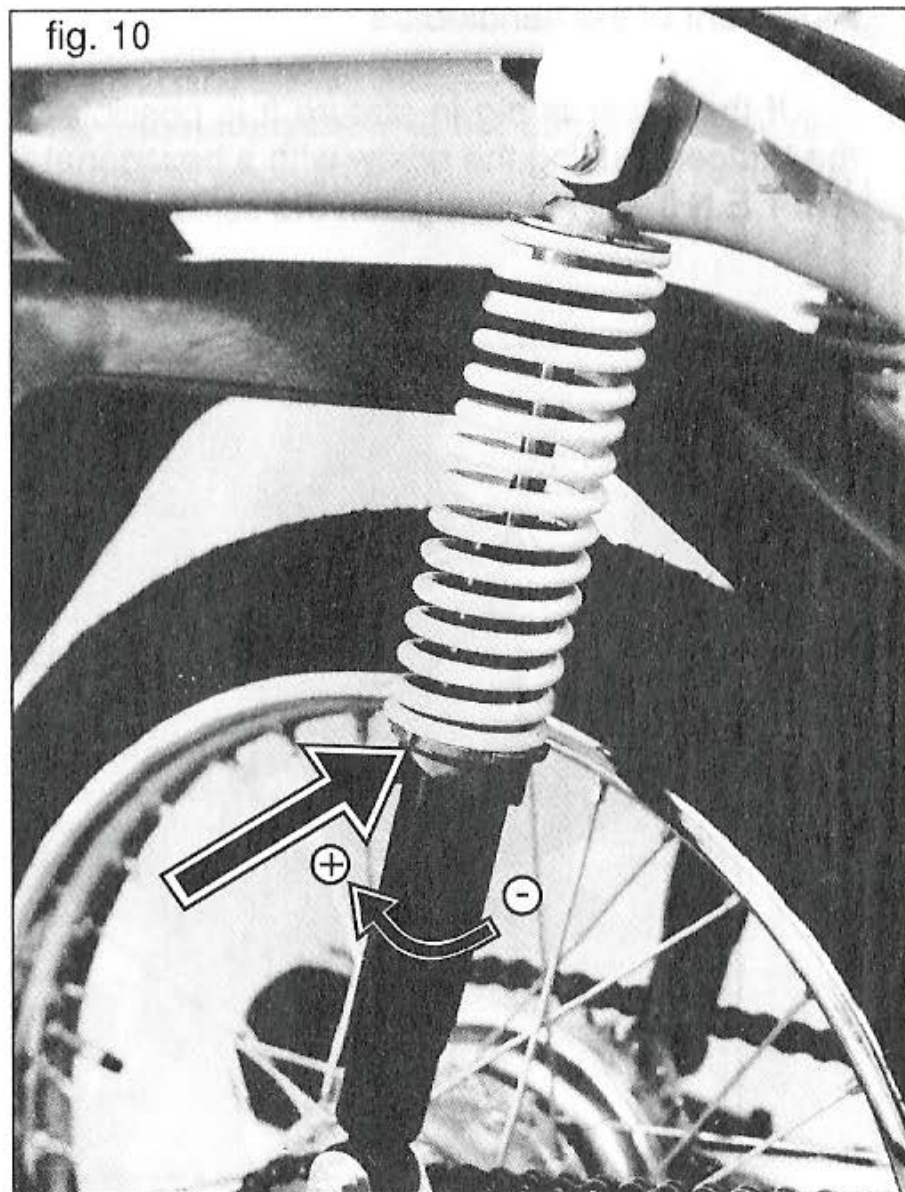

6 Maintenance table

Regular maintenance of the moped is the basic condition for its proper functioning. The below table shows what has to be performed after a how many kilometers. We recommend to have the work done in an authorized repair shop.

	0	1500	3000	6000	12000
1. Thorough cleaning of the vehicle		x	x	x	x
2. Check of tyre pressure	x	x	x	x	x
3. Check of lights	x	x	x	x	x
4. Check of the brake adjustment	x	x	x	x	x
5. Check of spark plug		x	x	x	x
6. Decarbonization of exhaust pipe				x	x
7. Decarbonization of cylinder head, exhaust port				x	x
8. Microfilter blasting				x	x
9. Check of connection parts		x	x	x	x
10. Check of carburettor			x	x	x
11. Check of clutch adjustment		x	x	x	x
12. Check of ignition contacts			x	x	x
13. Check of chain lubrication	x	x	x	x	x
14. Greasing of levers		x	x	x	x
15. Greasing of telescopic fork				x	x
16. Greasing of wheel bearings				x	x
17. Check of motor oil level	x		x	x	x
18. Greasing of bowdens				x	x
19. Greasing of steering head				x	x
20. Check of oil in oil dampers				x	x
21. Lubrication of foot transmission bearing			x	x	x
22. Lubrication of idle run pinion		x	x	x	x

7 Greasing of idle run pinion

<i>Pos.</i>	<i>Lubrication place</i>	<i>Used product</i>	<i>Remark</i>
1.	Engine	SHELL-SUPER 2T (oil for two-stroke engines SAE30)	gas-oil mixture ratio break-in 1 : 40 after break-in 1 : 50
2.	Gear box	SHELL-DONAX-TA oil for automatic gear boxes	
3.	Steering	SHELL Retinax A (grease)	Wash after dismantling and greace again.
4.	Gas twistgrip	Grease A00	Apply on sliding surfaces after washing.
5.	Brake and choke levers	SHELL Rotella TX 30	
6.	Bowdens	thin graphit oil	Pour into bowden sheeth
7.	Wheel bearings	SHELL Retinax A	
8.	Pins of brake locks	Grease A00	Grease after cleaning.
9.	Chains	SHELL Chain Spray	
10.	Bearings and pedal shaft	SHELL Rotella TX 30	
11.	Telescopes	SHELL Rotella TX 30	
12.	Idle run pinion	SHELL Rotella TX 30	
13.	Cam and felt of ignition	SHELL Rotella TX 30	
14.	Speedometer drive	SHELL Retinax A thin graphit oil	for gears for bowden

8 Troubleshooting

Engine can not be started

Engine stalls

Engine stops and can not be started

Engine loses power

Engine does not run in idle run

					<i>Cause of defect</i>	<i>Remedy</i>
x					Fuel cock closed	Open fuel cock
x		x			Empty fuel tank	Refill fuel
x	x		x	x	Partially stopped fuel line	Even out the fuel line
			x	x	Badly mixed gas-oil mixture	Mix properly before filling
		x	x		Stopped vent hole of fuel tank cap	Clean it
x	x	x	x		Clogged fuel strainer	Clean
x	x	x	x		Short-circuit on spark plugs, bad plug	Clean or exchange spark plug
x	x	x			Contaminated or bad ignition contacts	Clean, replace
x	x		x	x	Incorrectly adjusted ignition	Adjust (in repair shop)
x	x	x		x	Water or oil in carburettor	Clean
				x	Carbon deposits in cylinder or silencer	Remove carbon deposits
		x	x	x	Overheated engine	Let engine cool down
x					Flooded engine	Clean the spark plug
				x	Incorrectly adjusted carburettor	Adjust the idle run screw, check the gas bowden
			x		Clogged air filter	Clean

9 Electrical equipment diagram 6 V/20 W

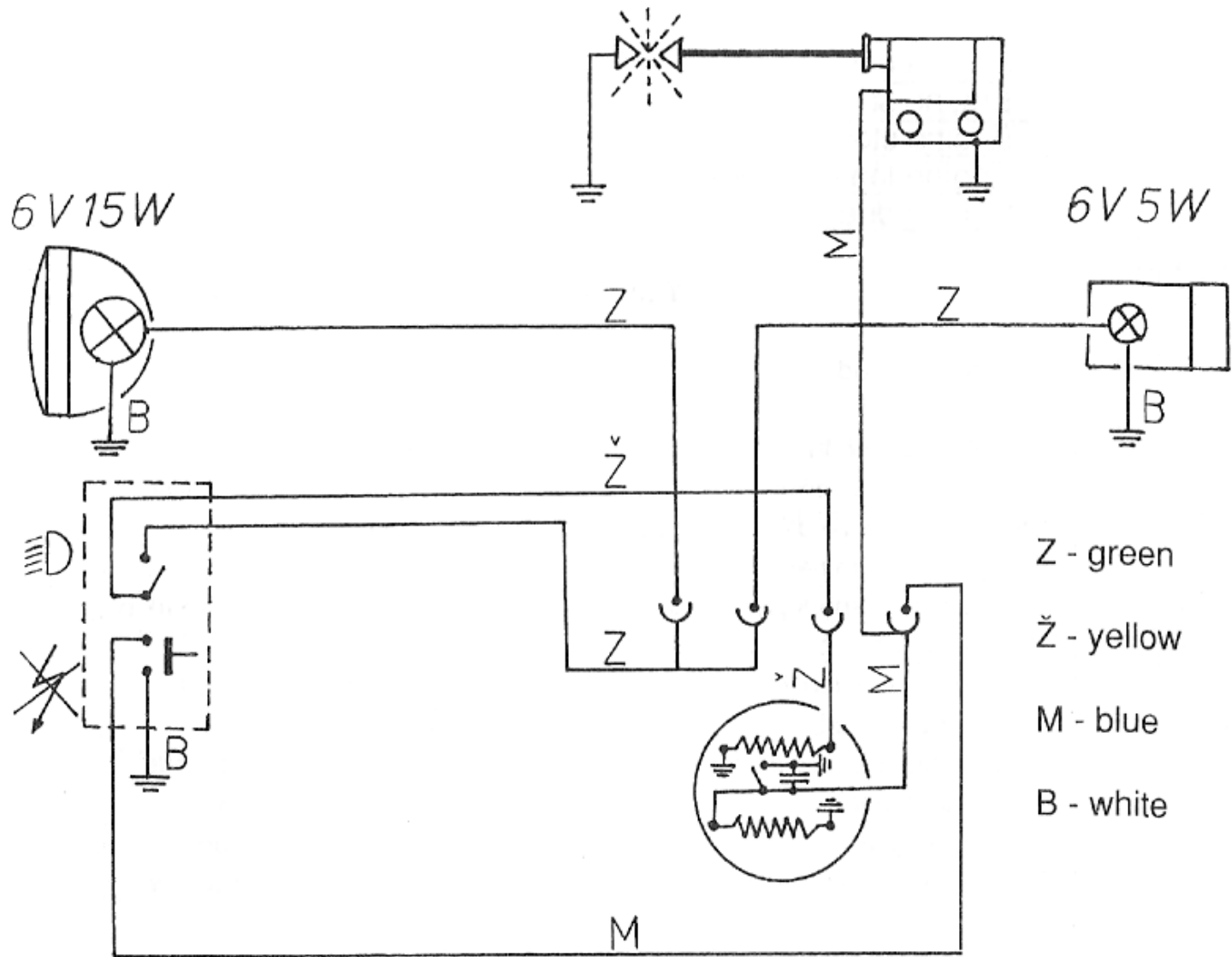

10 Tools and equipment

1. Spark plug spanner
2. Grip
3. Lock

11 Spare parts

The spare parts are to be ordered in an authorized repair shop. All repairs which are not specified in this manual should be carried out by an authorized repair shop.

12 Electrical equipment diagram 12 V/40 W /horn, speedometer light, blinkers, brake light/

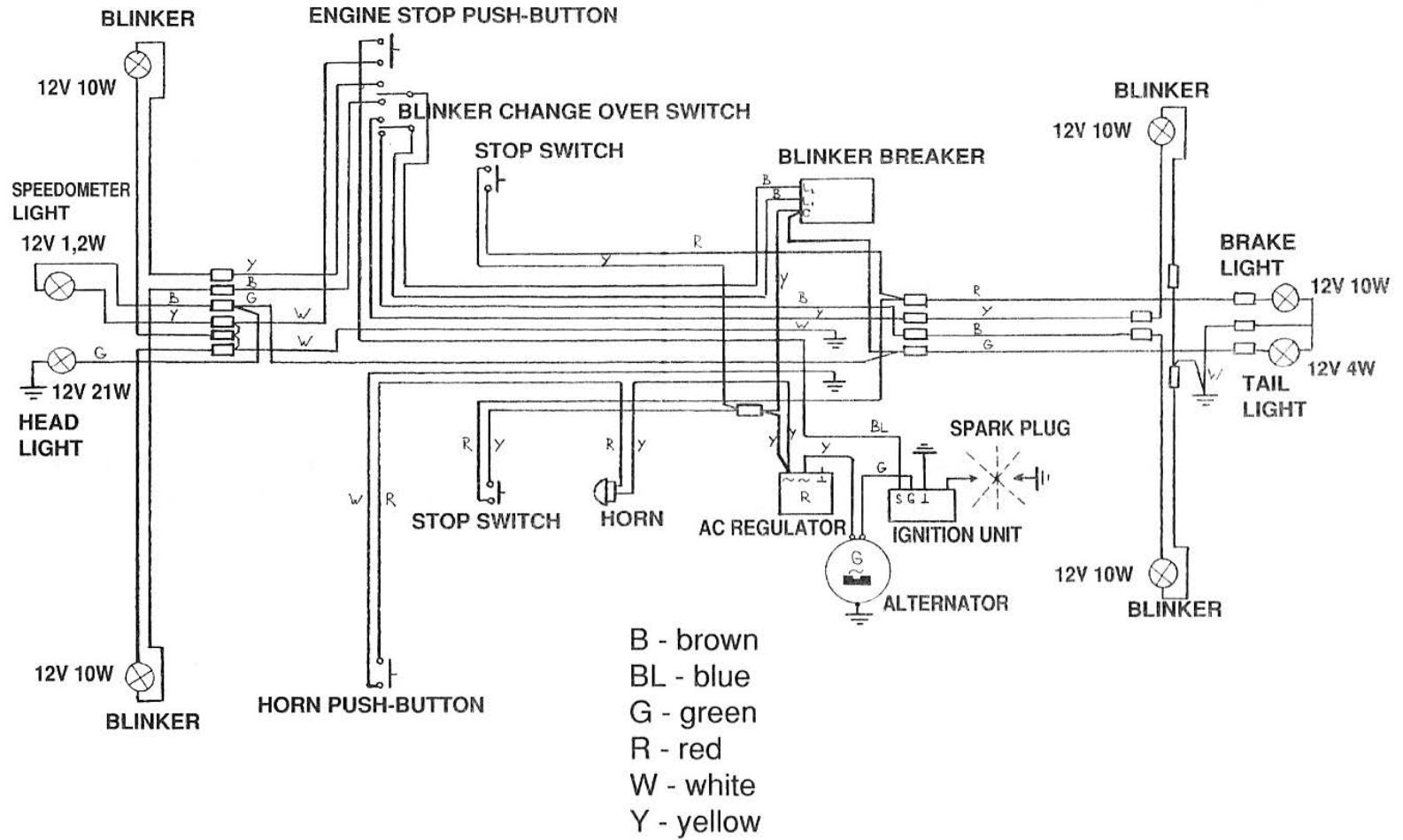

13 Electrical equipment diagram 12 V/40 W /horn, speedometer light/

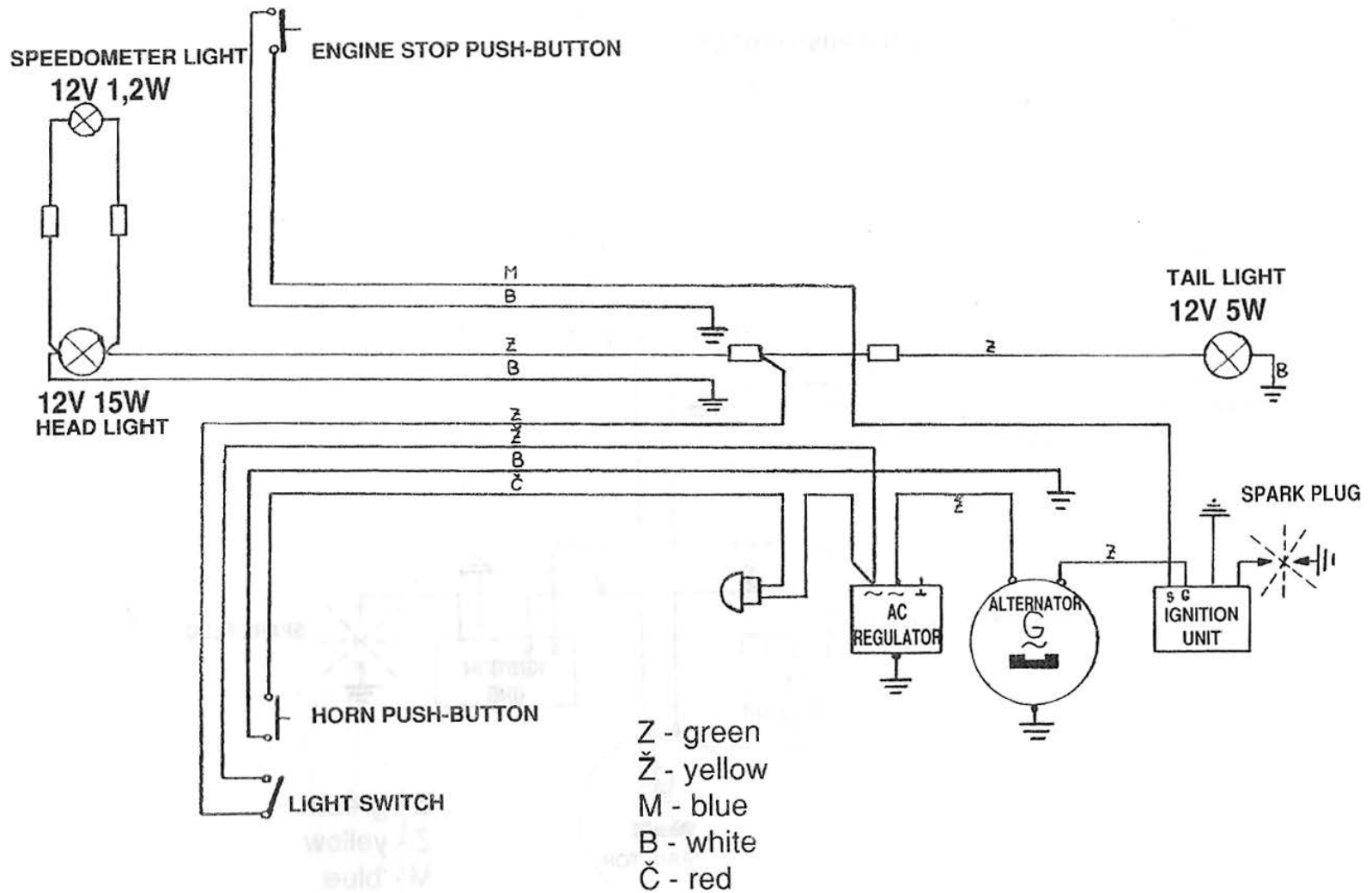

14 Electrical equipment diagram 12 V/40 W /speedometer light/

