

F1 CABLE / STEERING HANDLE

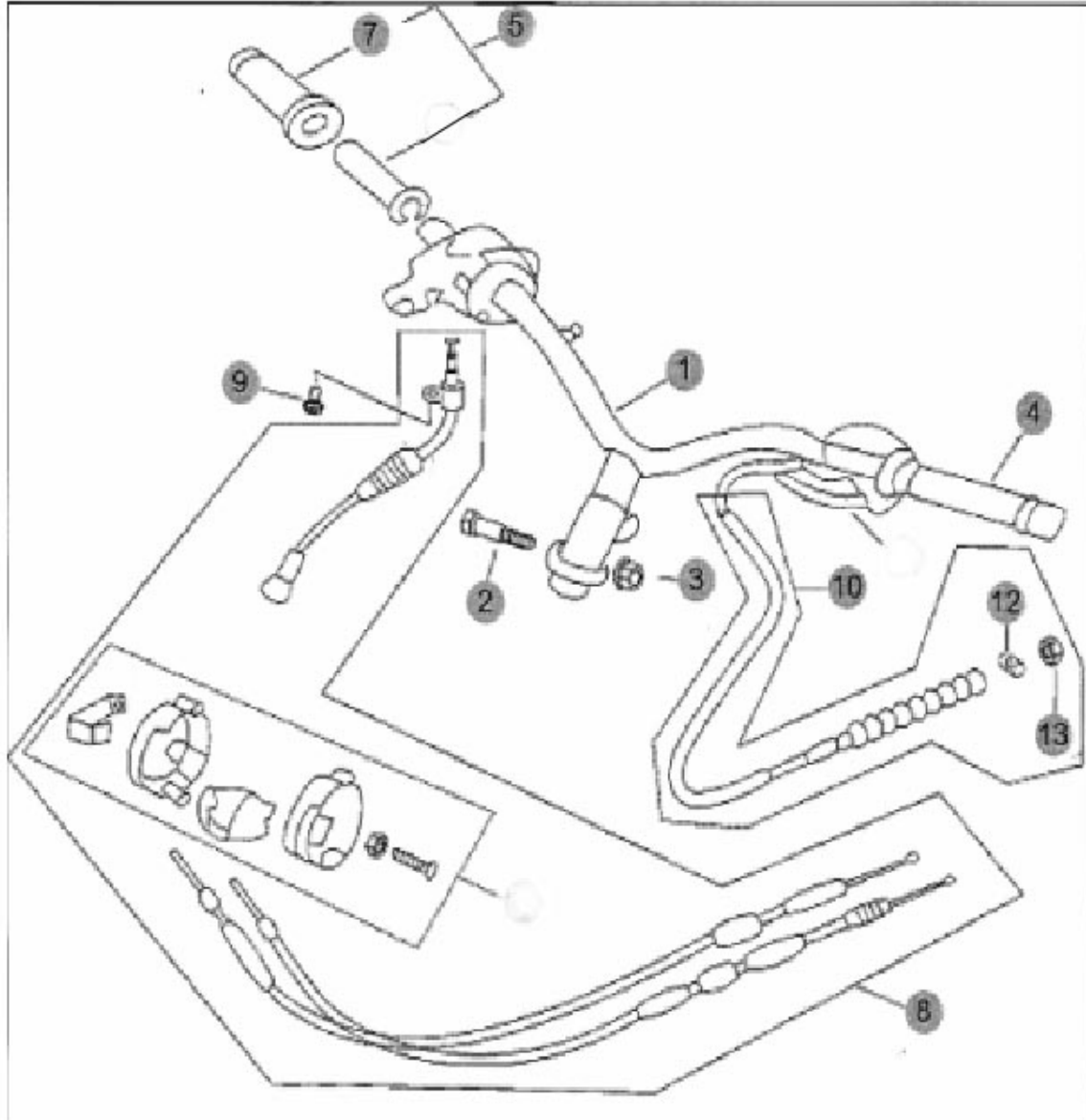

F1 CABLE / STEERING HANDLE			
NO.	CODE	DESCRIPTION	QTY.
1	Q0C09010010	HANDLE COMP.	1
2	B01091004565000	FLANGE SCREW 10×45	1
3	B04171000065000	FLANGE U NUT M10	1
4	Q0C09061020	L.H.GRIP	1
5	Q0C09023000	R.H.GRIP ASSY	1
7	Q0C09023020	THROTTLE GUIDE TUBE	1
8	Q0C09025000	THROTTLE CABLE ASSY	1
9	B02000501020	PAN HEAD SCREW 5×10	1
10	Q0C08046000	BRAKE CABLE	1
12	Q0C09063070	COLLAR BRAKE CABLE	1
13	Q0F09063080	ADJUSTING NUT	1

F2 LEVER / HANDLE SWITCH

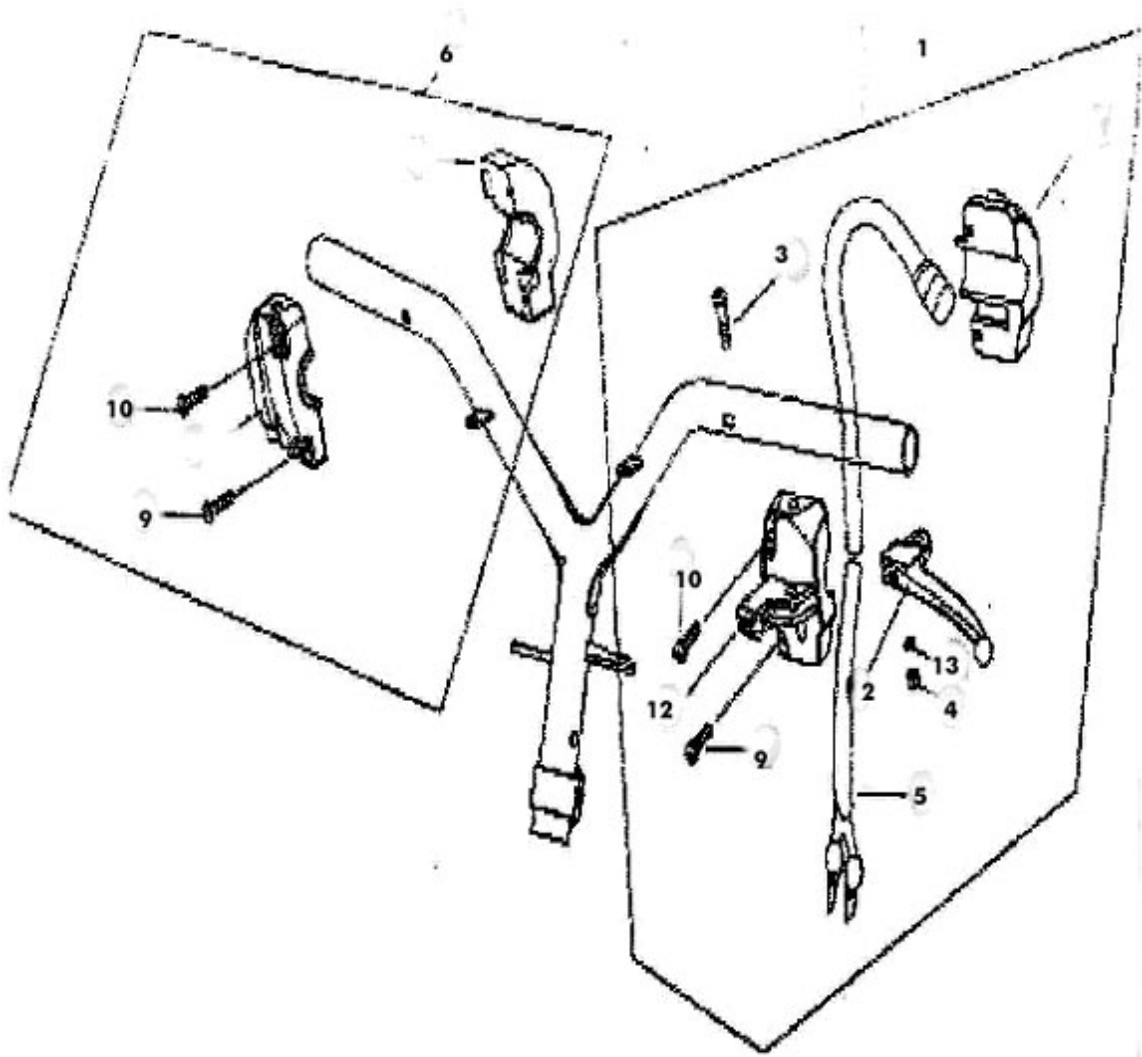

F2 LEVER / HANDLE SWITCH			
NO.	CODE	DESCRIPTION	QTY.
1	Q0C15011000	LEFT HANDLE SWITCH, 1	1
2	Q0C09061010	LEFT LEVER	1
3	Q0C09061030	LEVER MOUNTING SCREW5	1
4	B04000500045000	UNUT 5MM	1
5	Q0C09065000	STOP SWITCH ASSY.	1
6	Q0C15012000	RIGHT HANDLE SWITCH, 2	1
7	Q0C15012010	SWITCH ASSY RIGHT	1
8	Q0C15012020	SWITCH FIXING R.	1
9	B02000502020	PAN HEAD SCREW5×20	1
10	B02000502020	PAN HEAD SCREW5×225	1
11	Q0C15011010	SWITCH ASSY LEFT	1
12	Q0C15011020	BRAKE LEVER HOLDER	1
13	B07000000505	WASHER M5	1

F3 FRONT MASTER CALIPER

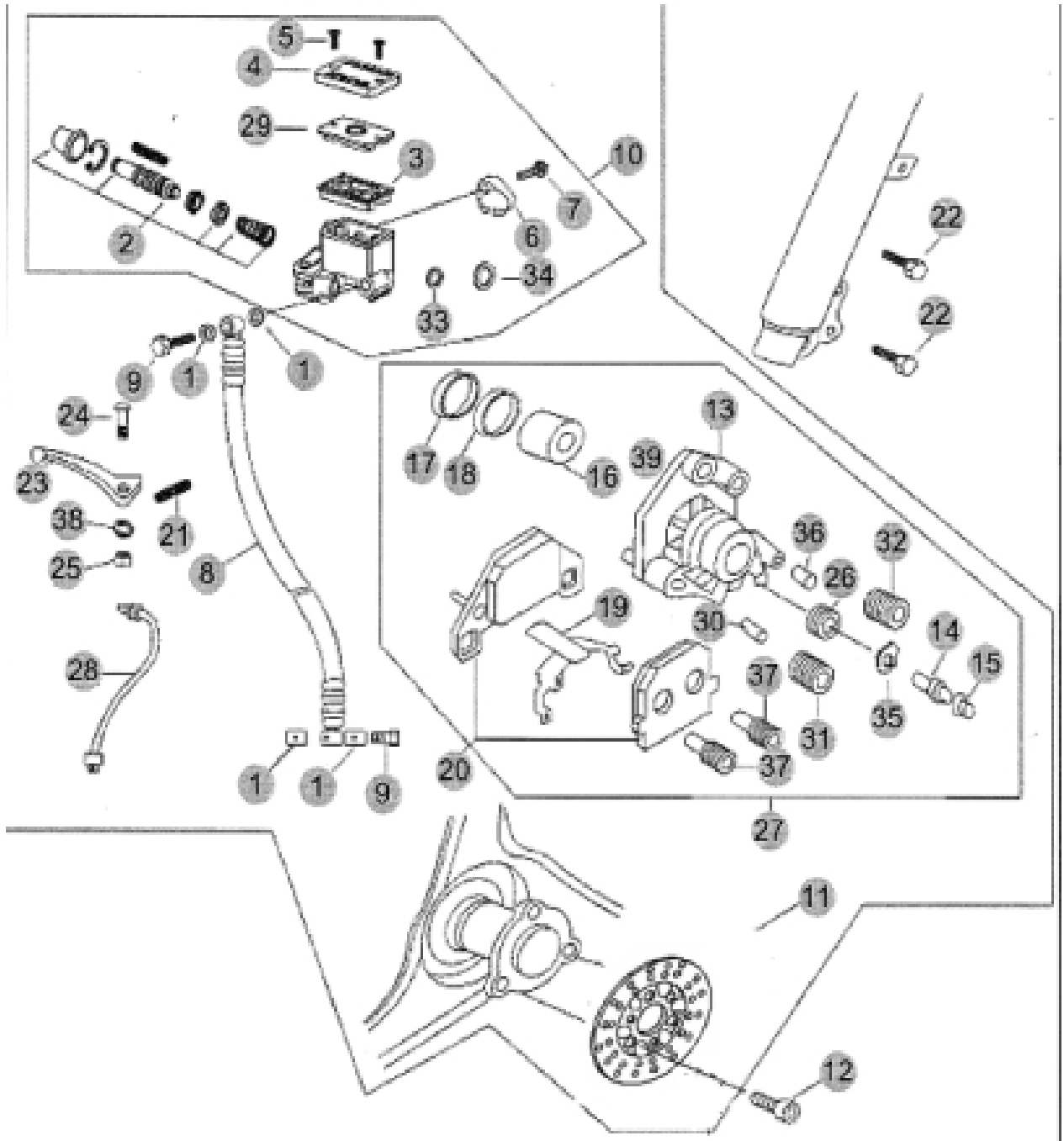

F3 FRONT MASTER CALIPER			
NO.	CODE		QTY
1	Q0C08012010	PLATE WASHER	4
2	Q0C08011030	PISTON ASSY	1
3	Q0C08011040	GASKET	1
4	Q0C08011020	COVER	1
5	B02010401025000	FLAT HEAD SREW M4×10	1
6	Q0C08011050	MASTER CYLINDER BRACKET	1
7	B01070602365000	SCREW M6×23	1
8	Q0C08012000	FR. BRAKE HOSE	1
9	Q0C08012070	UNION BOLT	2
10	Q0C08011000	CYLINDER COMPL	1
11	Q0C08015010	BRAKE DISC	1
12	Q0C08015030	BOLT 8×20 BLACK	3
13	Q0C08014060	CONNECTION BRACKET	1
14	Q0C08014020	BREED SCREW	1
15	Q0C08014030	BREED SCREW CAP	1
16	Q0C08013010	OIL PLUG	1
17	Q0C08013020	SEAL OIL PLUG	1
18	Q0C08013030	COVER DUST SEAL	1
19	Q0C08015020	PAD SUPPORT	1
20	Q0C08014070	BRAKE PAD KIT	2
21	Q0C08011060	TENSION SPRIG,LEVER	1
22	B010908035063000	BOLT 8×35	2
23	Q0C08011070	RIGHT LEVER	1
24	Q0C08011130	BOLT 6MM	1
25	B04000600045000	NUT 6MM	1
26	Q0C08014070	DUST COVER	1
27	Q0C08013000	CALIPER ASSY.	1
28	Q0C08011190	STOP SWITCH ASSY	1
29	Q0C0801110	COVER,CYLINDER	1
30	Q0C08014080	GUIDE AXLE	1
31	Q0C08014090	RUBBER GUIDE	1
32	Q0C08014100	RUBBER GUIDE	1
33	Q0C08014110	MIRROR OIL INSPECTION	1
34	Q0C08011120	GAKET OIL INSPECTION	1
35	Q0C0801410	WAVE WASHER	1
36	Q0C0801420	GUIDE AXLE	1
37	Q0C08014130	GUIDE POLE FIXING BRAKE PADS	1
38	Q0C08014140	WASHER	1
39	Q0C408014150	CONNECTION BRACKET	1

F4 FRONT FORK

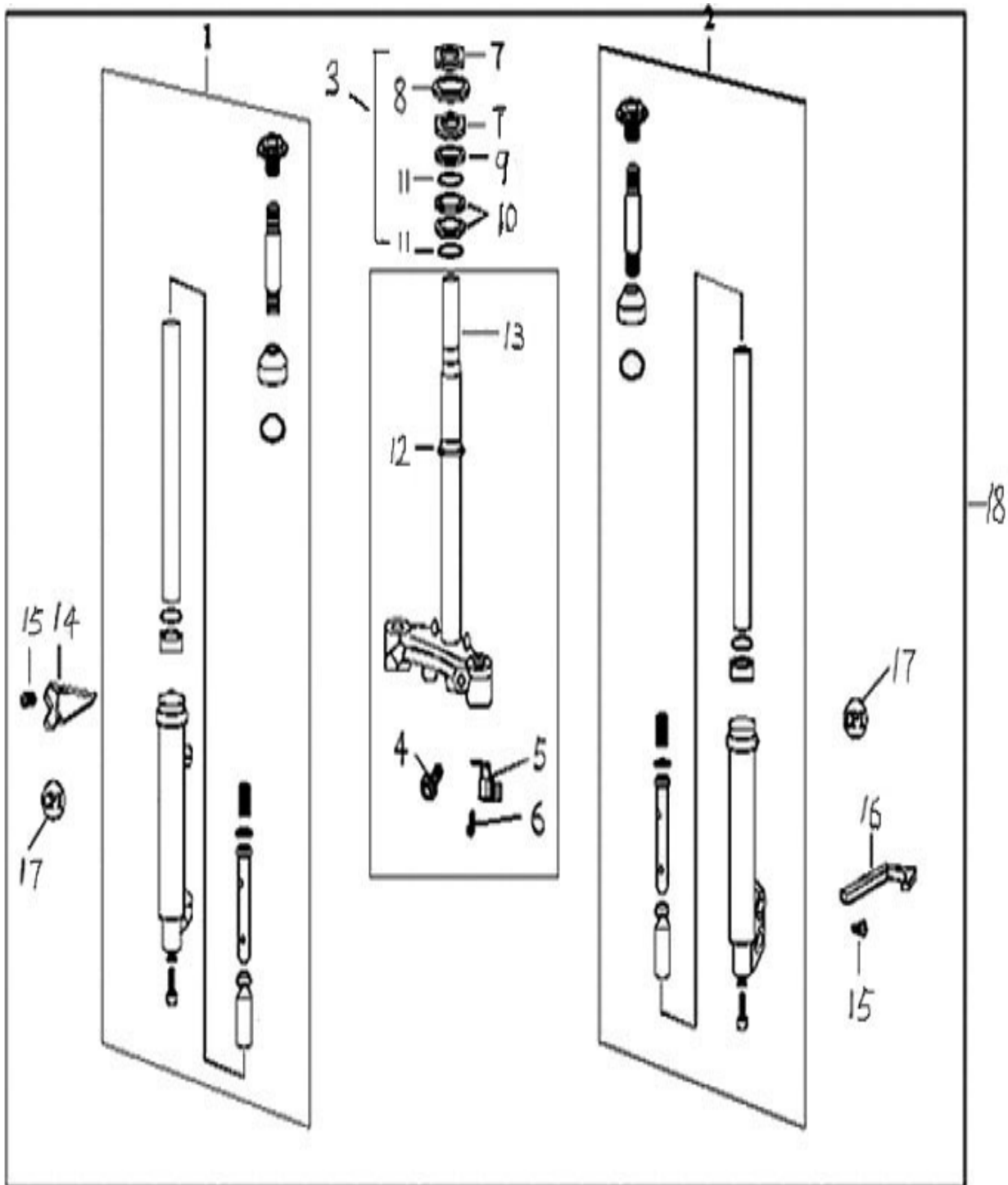

F4 FRONT FORK			
NO.	CODE	DESCRIPTION	QTY.
1	Q0C05010000	F.L. FORK ASSY.	1
2	Q0C05020000	F.R. FORK ASSY.	1
3	Q0C05063000	BALL RACE, 4	1
4	B01091003063000	FLANGE BOLT 10×30 (BLACK	2
5	Q0C08012030	FR. BRAKE HOSE HOLDER,2	1
6	B01090601263000	FLANGE BOLT 6×12 (BLACK	1
7	Q0C05061030	NUT (BLACK	2
8	Q0C05061140	BALL RACE COVER (BLACK	1
9	Q0C05063030	BALL RACE, 1(GOLD COLORED)	1
10	Q0C05063050	BALL RACE, 3	2
11	Q0C05063010	STEEL BALL 3/16”	42
12	Q0C05063040	BALL RACE, 2	1
13	Q0C05061100	FRONT STEM	1
14	Q0C17021100	CABLE HOLDER	1
15	B01090601663000	FLANGE BOLT 6×16 (BLACK	2
16	Q0C08012020	FR. BRAKE HOSE HOLDER,1	1
17	Q0C18010160	STICKER CPI	2
18	Q0C05051000	FRONT FORK ASSY.	1

F5 REAR SUSPENSION

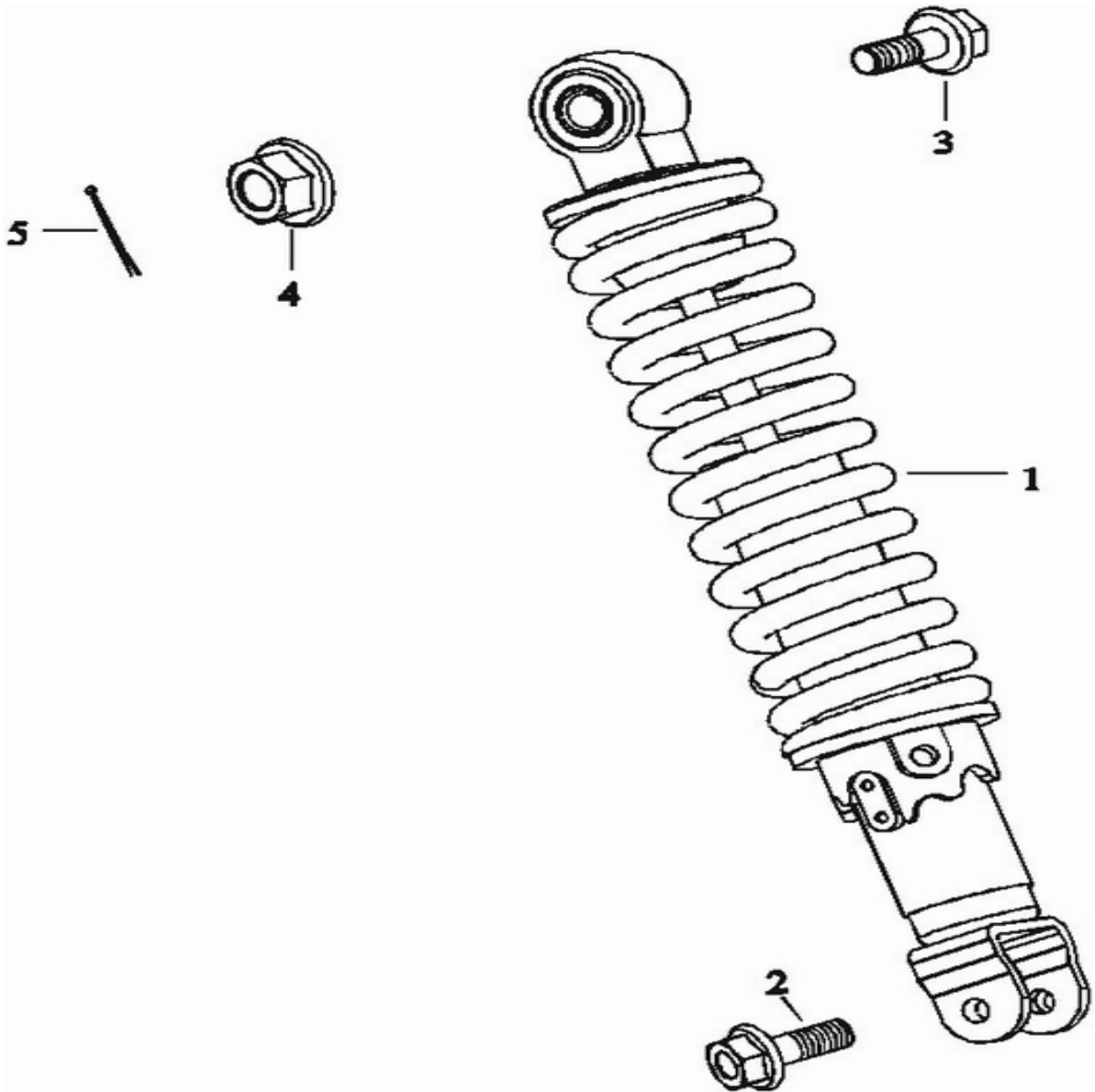

F5 REAR SUSPENSION			
NO.	CODE	DESCRIPTION	QTY.
1	Q0C06010000	RR.SHOCK ABSORBER ASSY	1
2	B01090803263000	FLANGE BOLT8×32 (BLACK	1
3	B01111004063000	BOLT W/HOLE 10×40 (BLACK	1
4	B04081012563000	FLANGE NUT 10X1.25MM	1
5	B09002501800000	SPLITPIN 2.5×18	1

F6 FRAME BODY

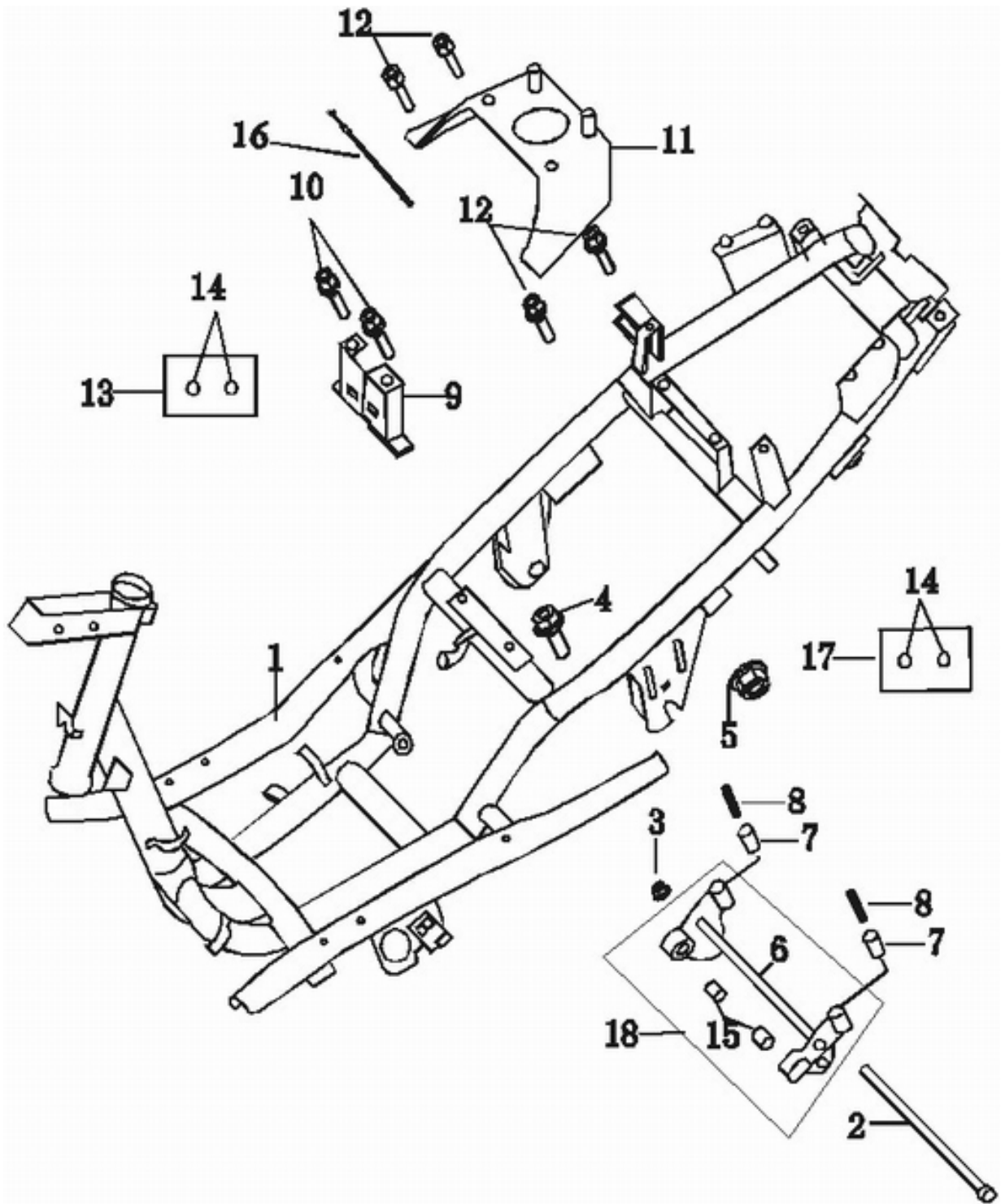

F6 FRAME BODY			
NO.	CODE	DESCRIPTION	QTY.
1	Q0C03010000	FRAME COMP	1
2	Q0C03051030	E/G MOUNTING BOLT,1(GOLD COLORED)	1
3	B04171212563000	FLANGE UNUT M12×1.25(GOLD COLORED)	1
4	Q0C03052070	E/G MOUNTING BOLT, 2 (BLACK	2
5	B04171012565000	FLANGE UNUT M10×1.25 (BLACK	2
6	Q0C03051070	E/G BRKT.COMP	1
7	Q0C03051040	DAMPER	2
8	Q0C03051090	SPRING	2
9	Q0C15064020	SEAT CATCH COMP	1
10	B01090602063000	FLANGE BOLT 6×20 (BLACK	2
11	Q0C14010080	CARRIER BRACKET	1
12	B01090601263000	FLANGE BOLT 6×12 (BLACK	4
13	Q0C18010160	FRAME BODY NO PLATE	1
14	B10073200700000	RIVET 3.2×7	4
15	Q0C03051010	BUFFER, ENGINE BRACKET	2
16	Q0C15064000	SEAT CABLE	1
17	Q0C18010180	PLATE ANTI-TAMPERING	1
18	Q0C03051000	E/G BRKT COMP.	1

F7 FRONT WHEEL

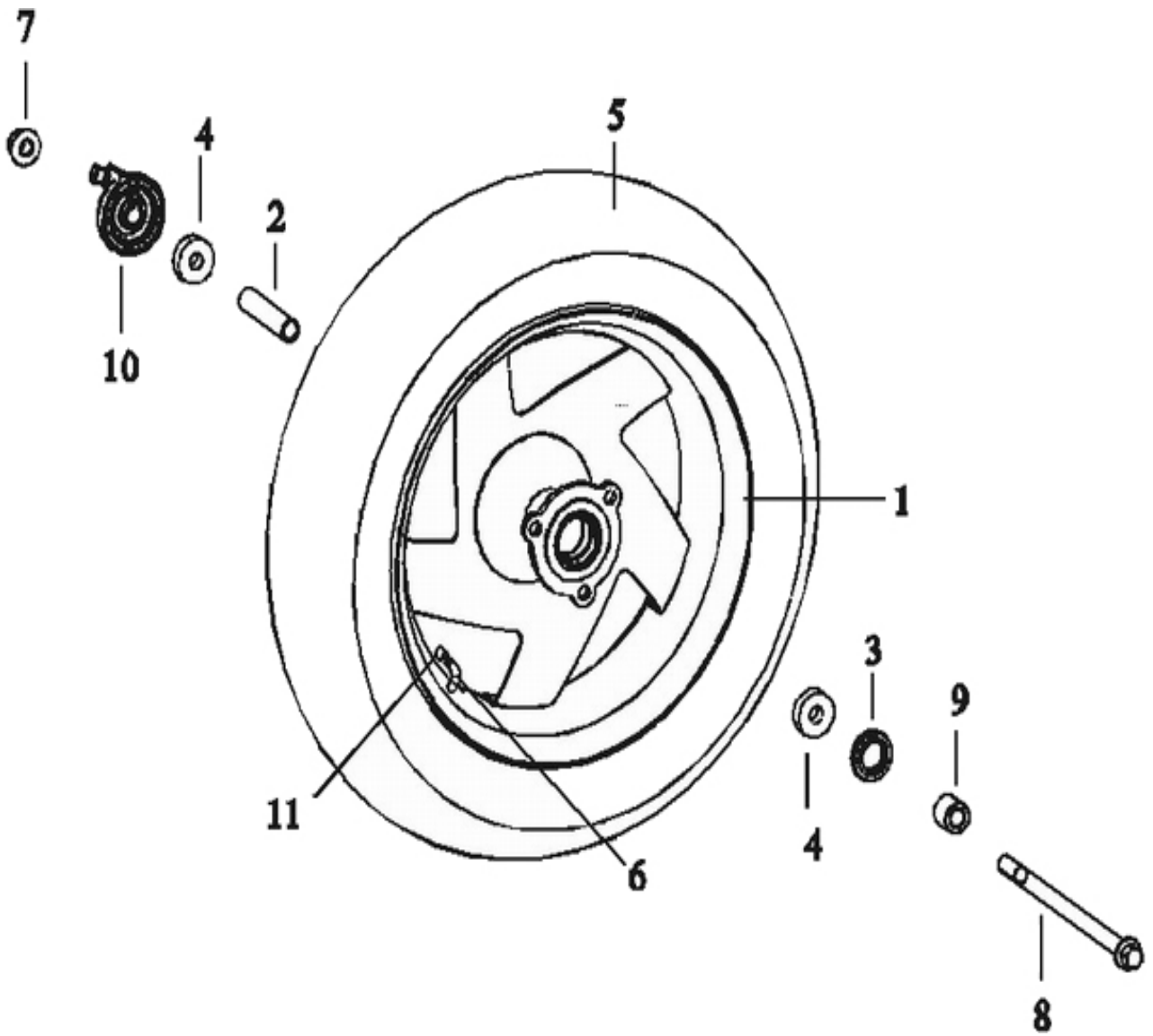

F7 FRONT WHEEL			
NO.	CODE	DESCRIPTION	QTY.
1	Q0C07013010	RIM COMP.3.5×12"	1
2	Q0C07012070	DISTANCE COLLAR COMP	1
3	Q0C07012090	OIL SEAL 22×35×7	1
4	Q0C07012140	BALL BEARING 620-2RS	2
5	Q0C07014040	TIRE 120/70-12	1
6	Q0C07014060	RIM VALVE	1
7	B04171200063000	FLANGE UNUT(GOLD COLORED)	1
8	Q0C07012080	FR.WHEEL AXLE 12×224(GOLD COLORED)	1
9	Q0C07012100	COLLAR	1
10	Q0C07011000	SPEEDOMETER GEAR COMP.	1
11	Q0C07014050	CAP, VALVE	1

F8 REAR WHEEL

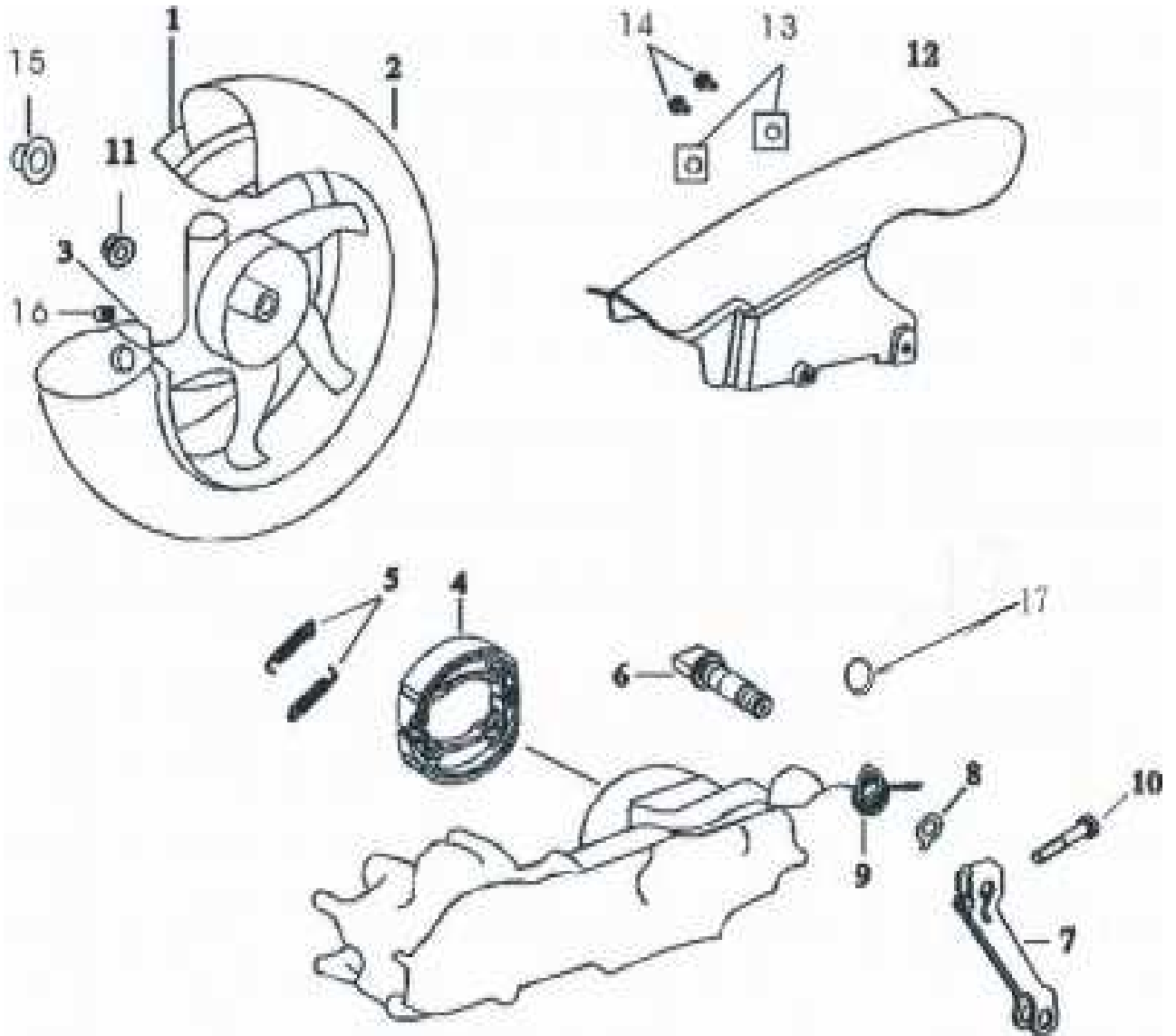

F8 REAR WHEEL			
NO.	CODE	DESCRIPTION	QTY.
1	Q0C07022010	RIM COMP.3.5×12"	1
2	Q0C07023040	TIRE 130/70-12	1
3	Q0C07023050	RIM VALVE Z2-01-1	1
4	Q0C08041120	BRAKE SHOE KIT(和土耳其客人的一)	1
5	Q0C08041070	SPRING	2
6	Q0C08041030	CAM SHAFT,2	1
7	Q0C08041020	CAM SHAFT LEVER,2	1
8	Q0C08041080	INDICATOR PLATE	1
9	Q0C08041050	INDICATOR PLATE	1
10	B01090602842000	HEX.BOLT	1
11	B04171615063000	UNUT 16×1.5MM(GOLD COLORED)	1
12	Q0C040500100066	REAR FENDER	1
13		SPRING NUT 6MM(BLACK)	2
14	B01090602063000	FLANGE BOLT M6X20(BLACK)	2
15	Q0C7022030	CAP	1
16	Q0C7023060	CAP, VALVE	1
17	Q0C08041100	FELT RING	1

F9 FUEL TANK

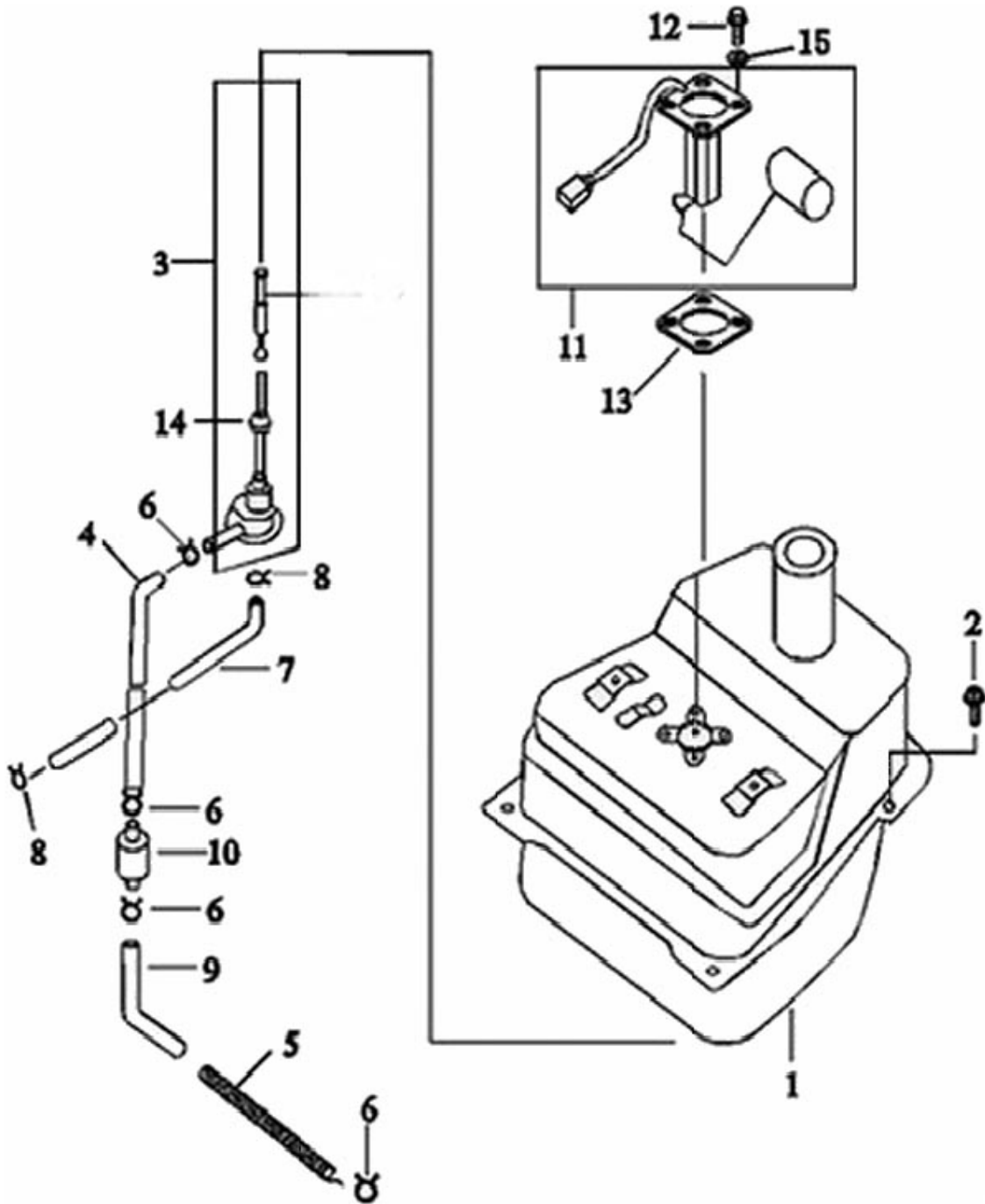

F9 FUEL TANK			
NO.	CODE	DESCRIPTION	QTY.
1	Q0C11011000	FUEL TANK COMP.	1
2	B01090601263000	FLANGE BOLT 6×12(BLACK)	4
3	Q0C11030000	FUEL COCK COMP.	1
4	T5E11060010	FUEL HOSE, 1	1
5	Q0C11060160	SPRING	1
6	Q0C11060040	CLIP 8MM	4
7	T5E11060030	VACUUM HOSE	1
8	Q0C11060040	CLIP 7MM	2
9	T5E11060020	FUEL HOSE, 2	1
10	P4A11050000	FUEL FILTER ASSY.	1
11	Q0C11041000	SENDER UNIT	1
12	B01030501623000	BOLT W/WASHER 5×16(GOLD COLORED)	4
13	Q0C11040010	GASKET	1
14	Q0C11030030	SEAL RING	1
15	B07030000503000	WASHER 5 (GOLD COLORED)	4

F10 OIL TANK

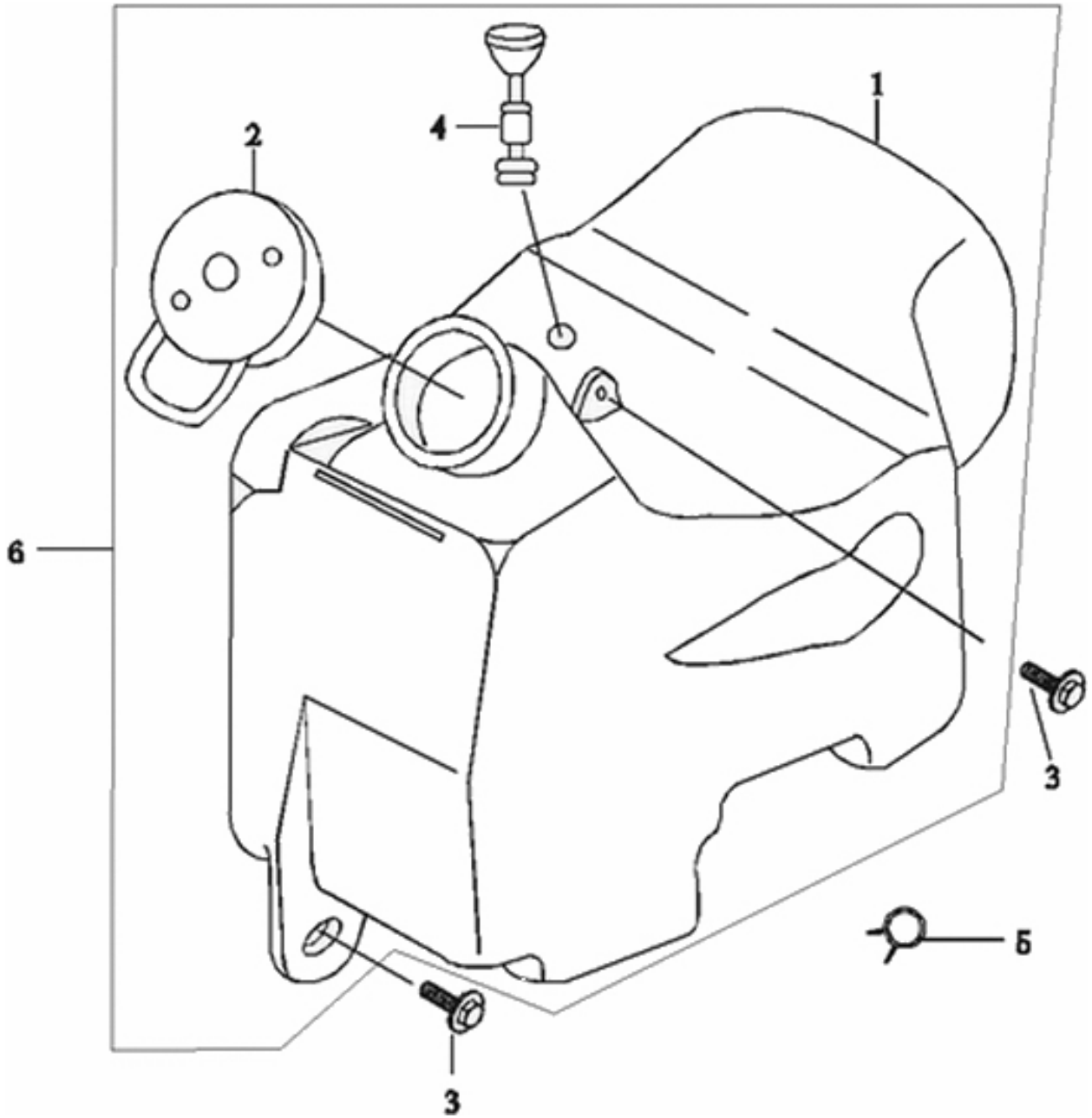

F10 OIL TANK			
NO.	CODE	DESCRIPTION	QTY.
1	Q0C12010000	OIL TANK	1
2	Q0C12020000	OIL TANK CAP	1
3	B01090601223000	BOLT 6×12(BLACK)	2
4	Q0C12060000	OIL LEVER GAUGE ASSY	1
5	Q0C12010010	CLIP 8	1
6	Q0C12000000	OIL TANK ASSY.	1

F11 HANDLE COVER

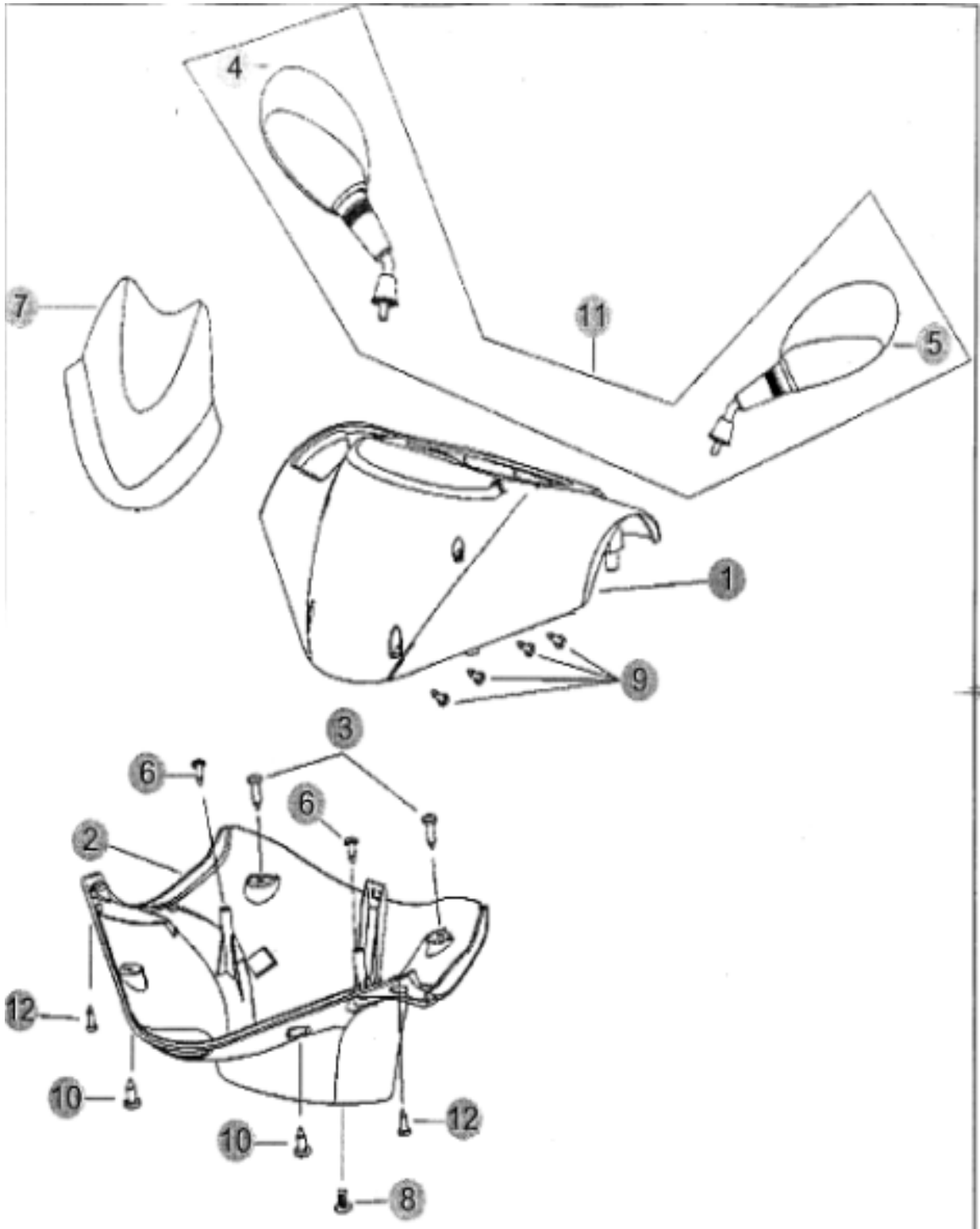

F11 HANDLE COVER			
NO.	CODE	DESCRIPTION	QTY.
1	Q0C04020010	HANDLE COVER, 1	1
2	Q0C04020030	HANDLE COVER	1
3	B05004801205000	TAPPING SCREW4.8×12(BLACK)	2
4	Q0F09072000	RIGHT MIRROR	1
5	Q0F09071000	LEFT MIRROR	1
6	B05004801205000	TAPPING SCREW4.8×12(BLACK)	2
7	Q0C040200210067	METER VISOR.	1
8	B13050501605000	SCREW W/WASHER 5×16(BLACK)	1
9	B05002901005000	TAPPING SCREW2.9×9.5(BLACK)	4
10	B05004801205000	TAPPING SCREW4.8×12(BLACK)	2
11	Q0F09070000	REAR VIEW MIRROR ASSY	1
12	B05004801205000	TAPPING SCREW4.8×12(BLACK)	2

F12 METER

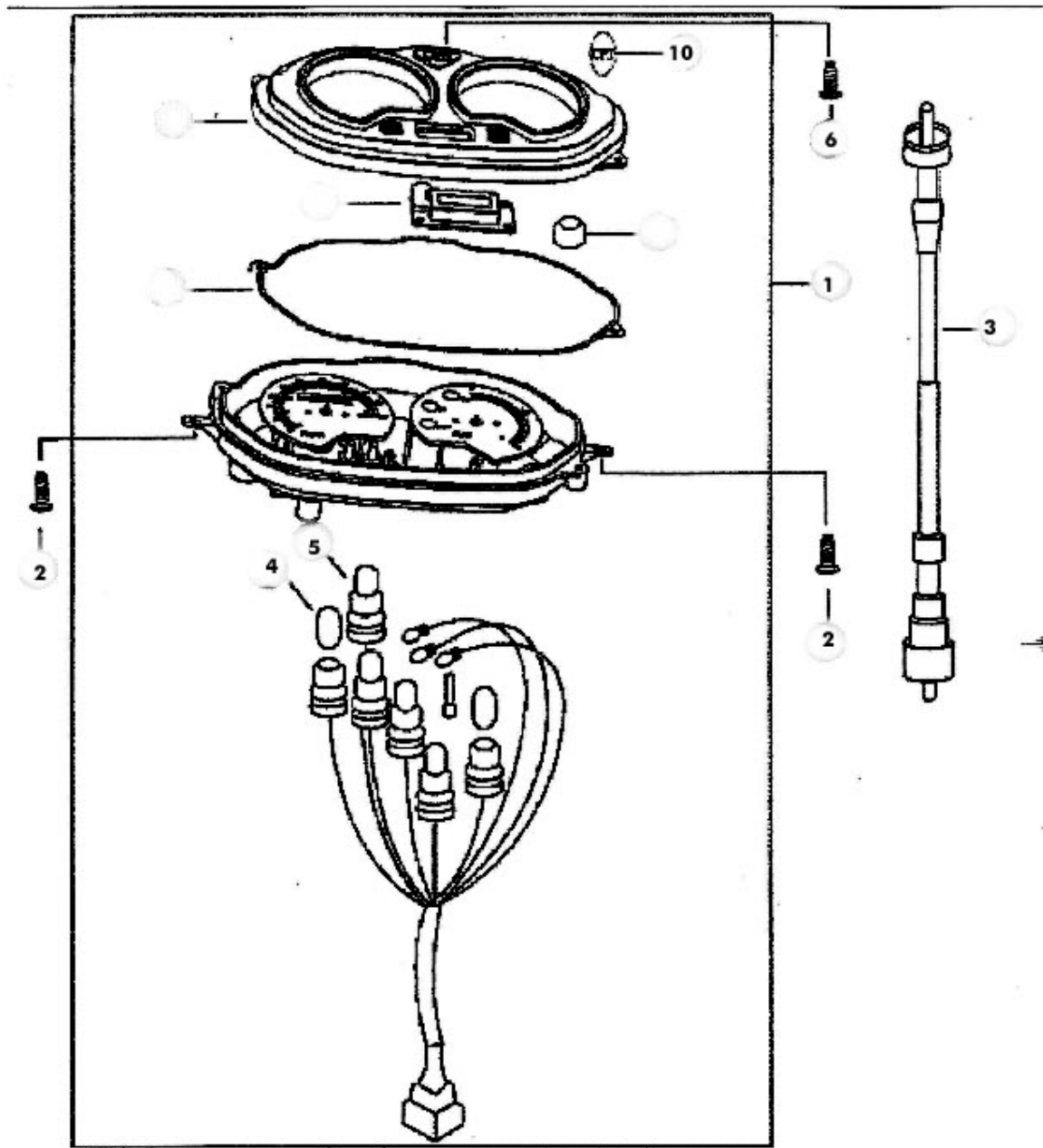

F12 METER			
NO.	CODE	DESCRIPTION	QTY.
1	Q0C17010000	SPEEDOMETER ASSY (WITH "CPI"LOGO)	1
2	B05004801205000	TAPPING SCREW4.8×12(BLACK)	2
3	Q0C17020000	SPEEDOMETER CABLE ASSY	1
4	Q0C17011120	BULB 12V-3,4W	3
5	Q0C17011130	BULB 12V-1,7W	3
6	B05074001000	TAPPING SCREW4.8×10 (BLACK)	1
10	Q0C18010170	STICKER CPI	1

F13 FENDER

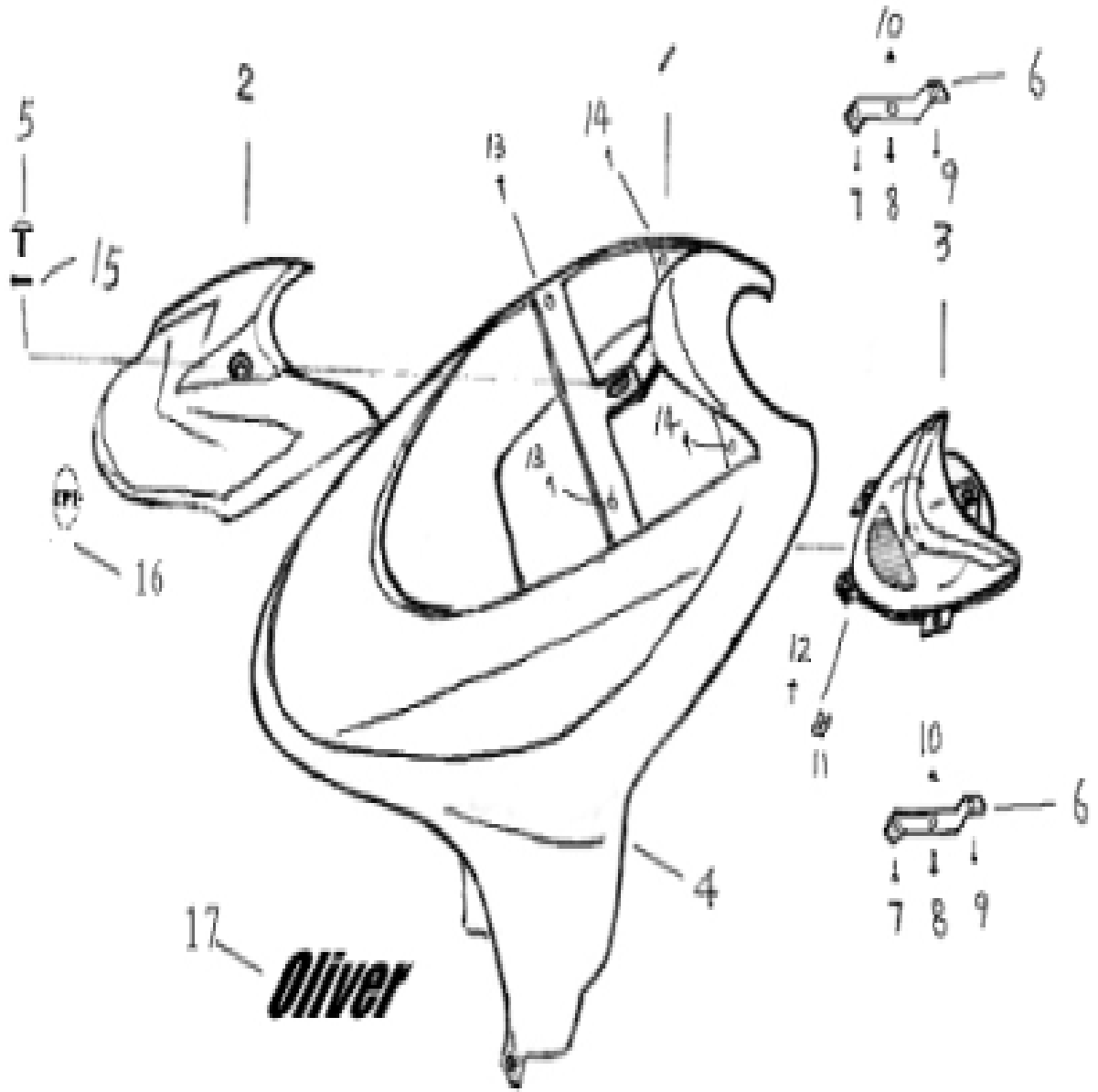

F13 FENDER			
NO.	CODE	DESCRIPTION	QTY.
1	Q0F04010050	LEG SHIELD,1,	1
	Q0F04010051	LEG SHIELD,1,	1
2	Q0F18020270	COVER, 1	1
	Q0F18020271	COVER, 1	1
3	Q0F16011000	HEAD LIGHT	1
4	B05004201605000	TAPPING SCREW 4.2×16(BLACK)	4
5	Q0C04010770	SCREW 6×16	1
6	Q0F16012010	HEAD LIGHT BRACKET	2
7	B05004201205000	TAPPING SCREW 4.2×12(BLACK)	2
8	B02000502063000	HEX. 5×20	2
9	B05004201605000	TAPPING SCREW 4.2×16(BLACK)	2
10	B04070500033000	NUT 5MM (GOLD COLORED)	2
11	4.2	SPRING NUT 4.2MM	1
12	B05004801605000	TAPPING SCREW 4.8×16(BLACK)	1
13	B05004201605000	TAPPING SCREW 4.2×16(BLACK)	2
14	B05004801205000	TAPPING SCREW 4.2×12(BLACK)	2
15	Q0C04010500	CUSHION, FR. COVER SCREW	1
16	Q0F18010170	STICKER CPI	1
17	Q0F180201010	YELLOW "OLIVER" STICK	2
	Q0F180201011	SILVER "OLIVER" STICK	2

F14 SIDE COVER

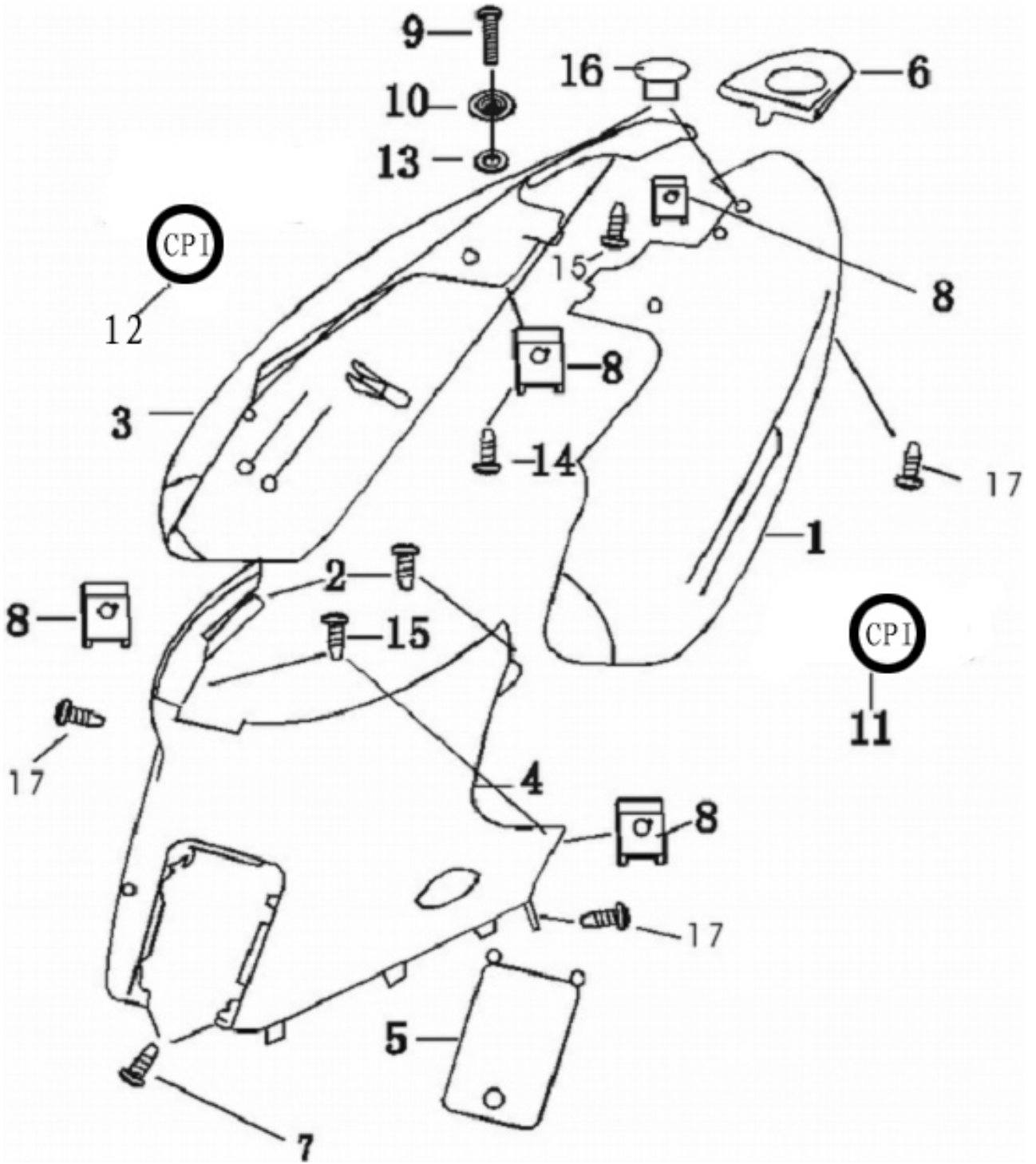

F14 SIDE COVER			
NO.	CODE	DESCRIPTION	QTY.
1	Q0C04010430	SIDE COVER,1	1
2	B05004201205000	TAPPING SCREW4.2×12 (BLACK	2
3	Q0C04010440	SIDE COVER,2	1
4	Q0C04010240	SIDE COVER,3	1
5	Q0C04010300	SIDE COVER,4	1
6	Q0C04010290	SIDE COVER,4	1
7	B05004801605000	TAPPING SCREW 4.8×16 (BLACK	2
8	4.2	SPRING NUT 4.2MM	2
9	B02000601663000	SCREW W/WASHER6×16(GOLD COLORED)	2
10	Q0C04010750	SEAT WASHER	2
11	Q0C18020010	STICKER,3	1
	Q0C18020011	STICKER,3	
12	Q0C18020020	STICKER,4	1
	Q0C18020021	STICKER,4	
13	Q0C04010500	RUBBER WASHER	2
14	B05004801205000	TAPPING SCREW 4.8X12 (BLACK	1
15	B05004801605000	TAPPING SCREW 4.8X16 (BLACK	2
16	Q0C04010560	CAP, DECORATION	2
17	B05004801605000	TAPPING SCREW 4.8X16 (BLACK	2

F15 SEAT ASSY

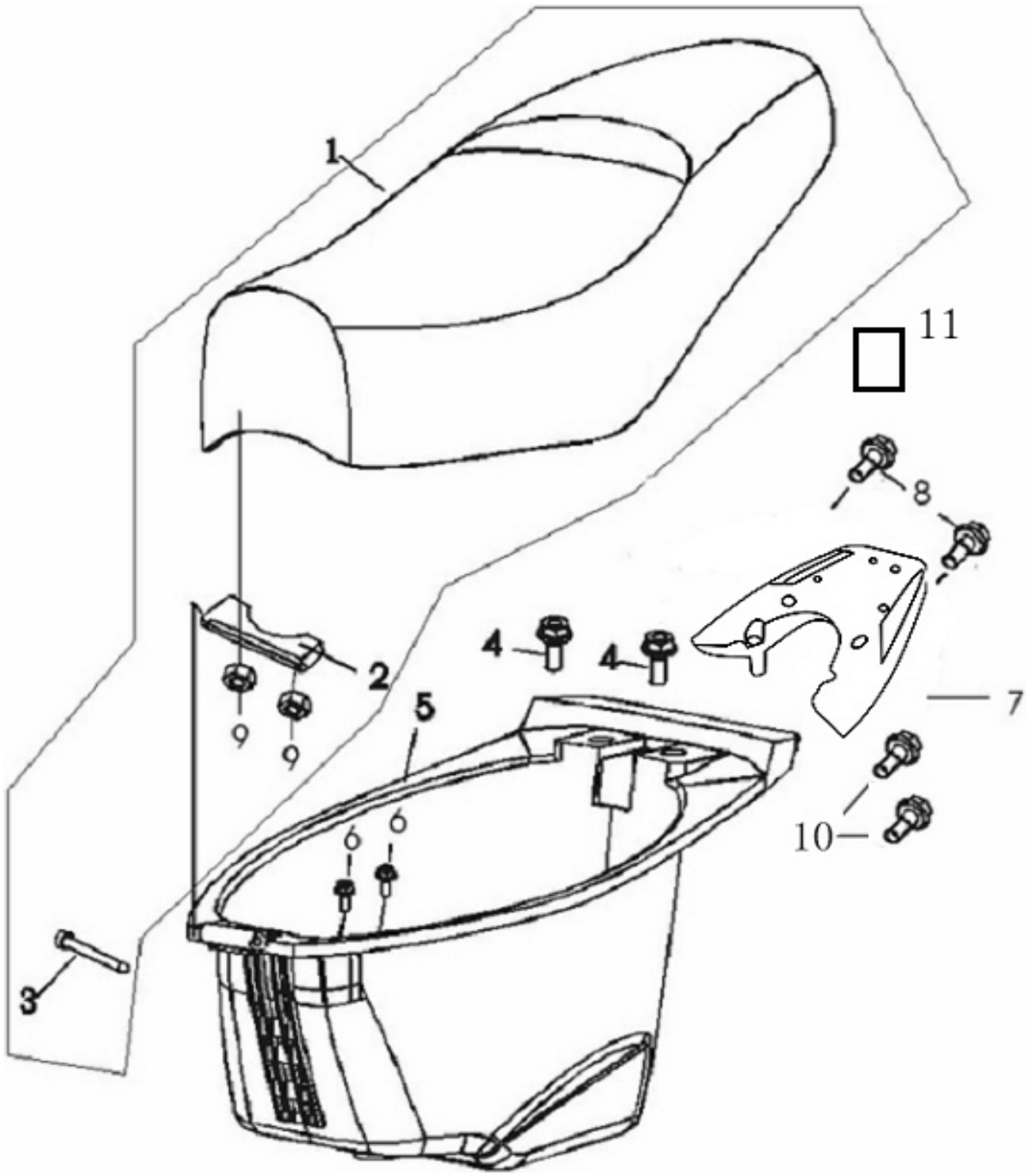

F15 SEAT ASSY			
NO.	CODE	DESCRIPTION	QTY.
1	Q0C13011000	DOUBLE SEAT ASSY.	1
2	Q0C13010060	SEAT HINGE	1
3	Q0C13010100	BOLT	1
4	Q0C15064040	BOLT (GOLD COLORED)	2
5	Q0C04010170	LUGGAGE BOX	1
6	B01090601263000	FLANGE BOLT 6×12 (BLACK	2
7	Q0C14030010	R.R LUGGAGE CARRIER COMP	1
8	B02050804065000	SOCKET BOLT 8×40	2
9	B0407080033000	NUT 6MM (GOLD COLORED)	2
10	B02050805065000	SOCKET BOLT 8×50	2
11	Q0F18020060	DOT STICKER	1

F16 LEG SHIELD

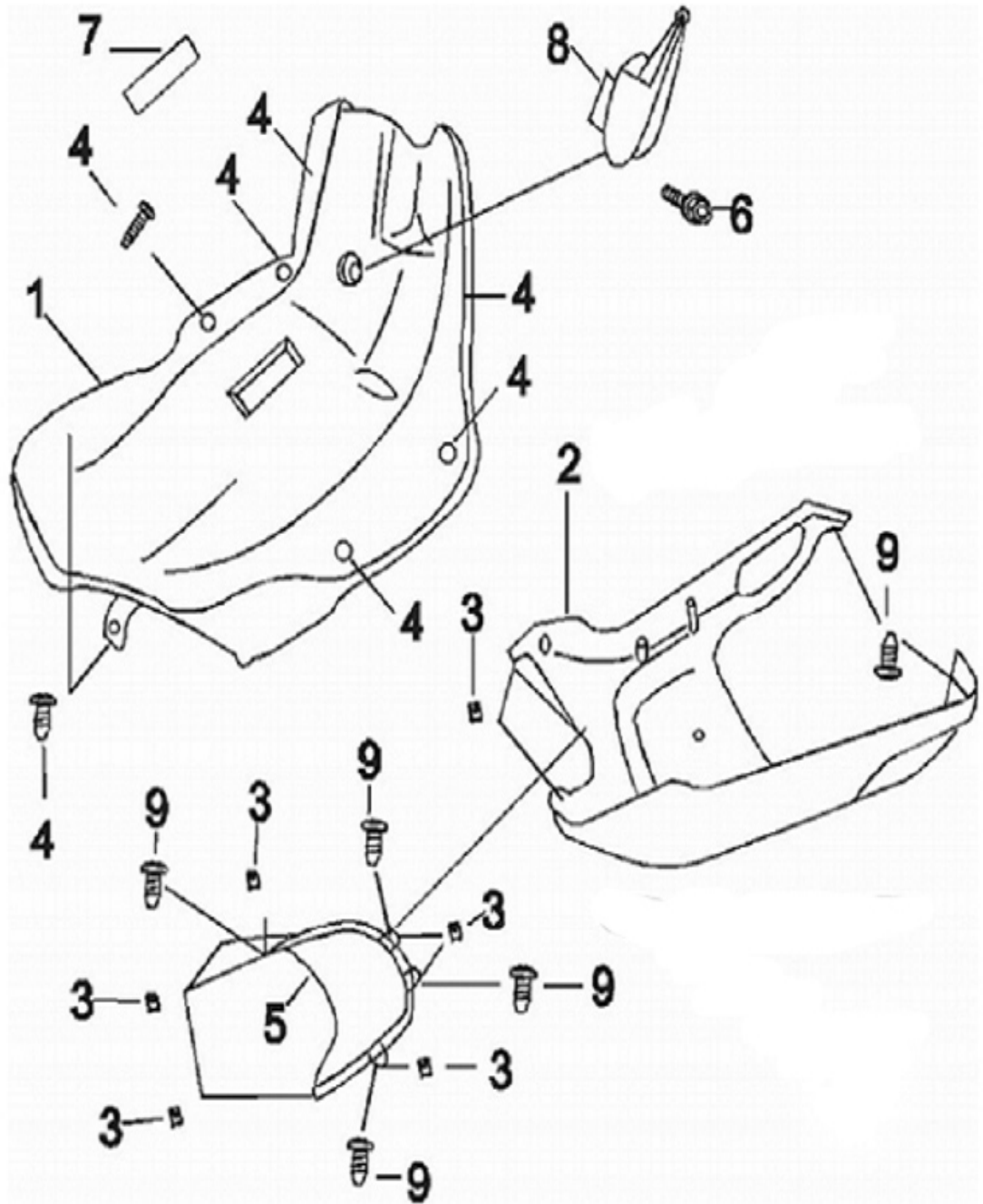

F16 LEG SHIELD			
NO.	CODE	DESCRIPTION	QTY.
1	Q0C04010460	LEG SHIELD,2	1
2	Q0C04010670	UNDER COVER (yellow)	1
	Q0C04010671	UNDER COVER (SILVER)	1
3	B04514800003000	SPRING NUT 4.8MM	6
4	B05004801605000	TAPPING SCREW4.8×16 (BLACK	6
5	Q0C040400800066	INNER FENDER.	1
6	B01090603063000	BOLT 6MM (BLACK	1
7	Q0C04010190	INSPECT COVER	1
8	Q0C04010700	HOOK	1
9	B05004201205000	TAPPING SCREW4.2×12 (BLACK	6

F17 STAND / FOOTREST

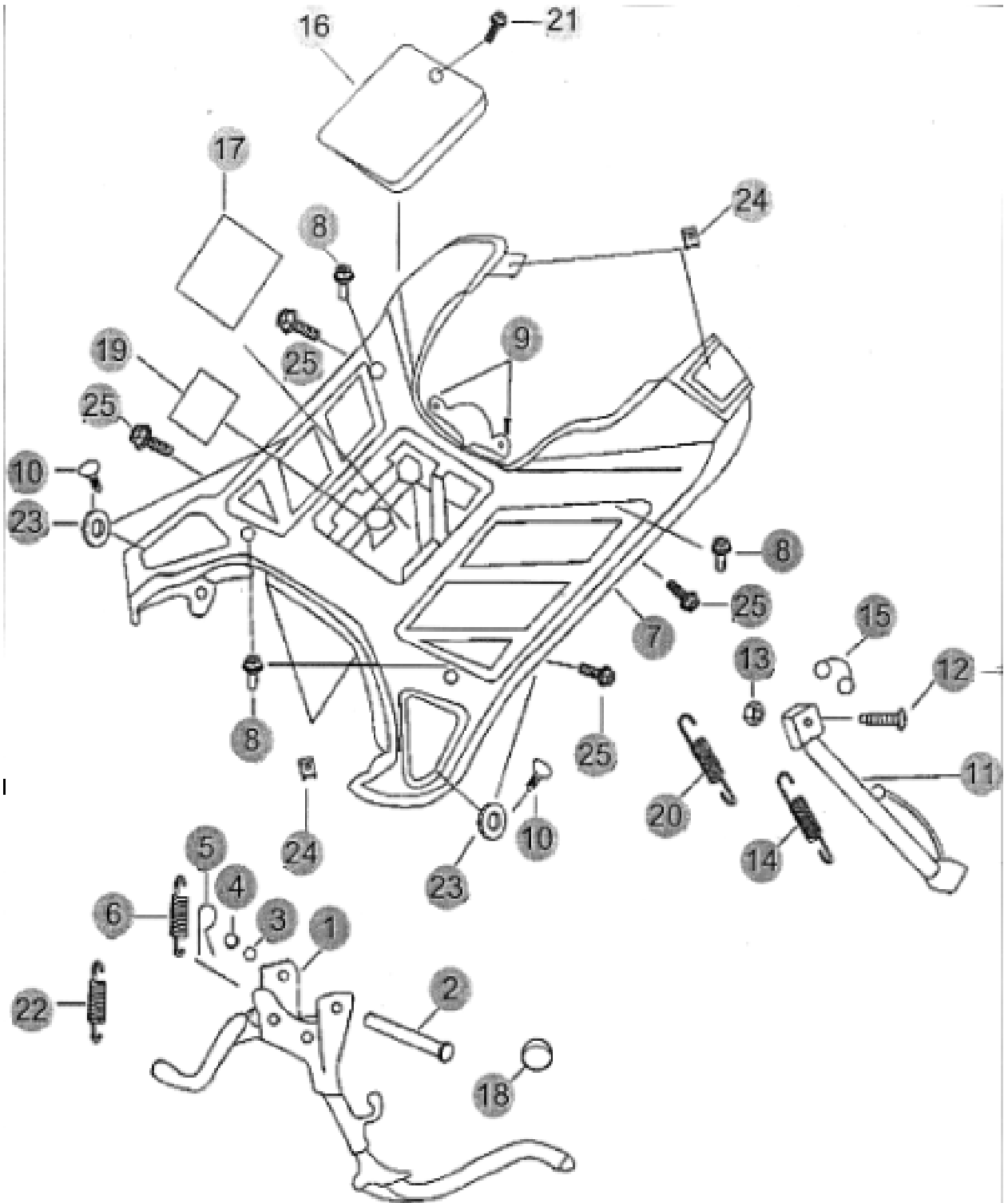

F17 STAND / FOOTREST			
NO.	CODE	DESCRIPTION	QTY.
1	Q0F0C03030000	MAIN STAND COMP	1
2	Q0C03032020	PIN	1
3	Q0C03032060	O-RING 10×1.9	1
4	B07030001002000	PLATE WASHER	1
5	B09002501802000	PIN 2.5×18	2
6	Q0C03032050	TENSION SPRING (DIG)	1
7	Q0C040102000066	FLOOR BLACK	1
8	B01090601663000	BOLT W/WASHER 6×16 (BLACK	4
9	B04514200003000	SPRING NUT 4.2MM	6
10	B05004801605000	TAPPING SCREW4.2×16 (BLACK	2
11	Q0C03041000	SIDE STAND COMP.	1
12	Q0C03042020	BOLT 8×22 (BLACK	1
13	B04070800025000	UNUT 8MM (BLACK	1
14	Q0C03042010	TENSION SPRING (DIG)	1
15	Q0C03042080	HOOK	1
16	Q0C04010220	BATTERY COVER	1
17	Q0C15030040	BATTERY DAMPER I	1
18	Q0C03032030	CUSHION, MID STAND	1
19	Q0C15030080	BATTERY DAMPER I	1
20	Q0C03042030	TENSION SPRING (SMALL)	1
21	B05004801605000	TAPPING SCREW 4.8X16 (BLACK	1
22	Q0C03032070	TENSION SPRING (SMALL)	1
23	B07030000502000	WASHER 5	4
24	B04514200003000	SPRING NUT 4.2MM	4
25	B01090601225000	BOLT 6X12 (BLACK	4

F18 TAIL LIGHT

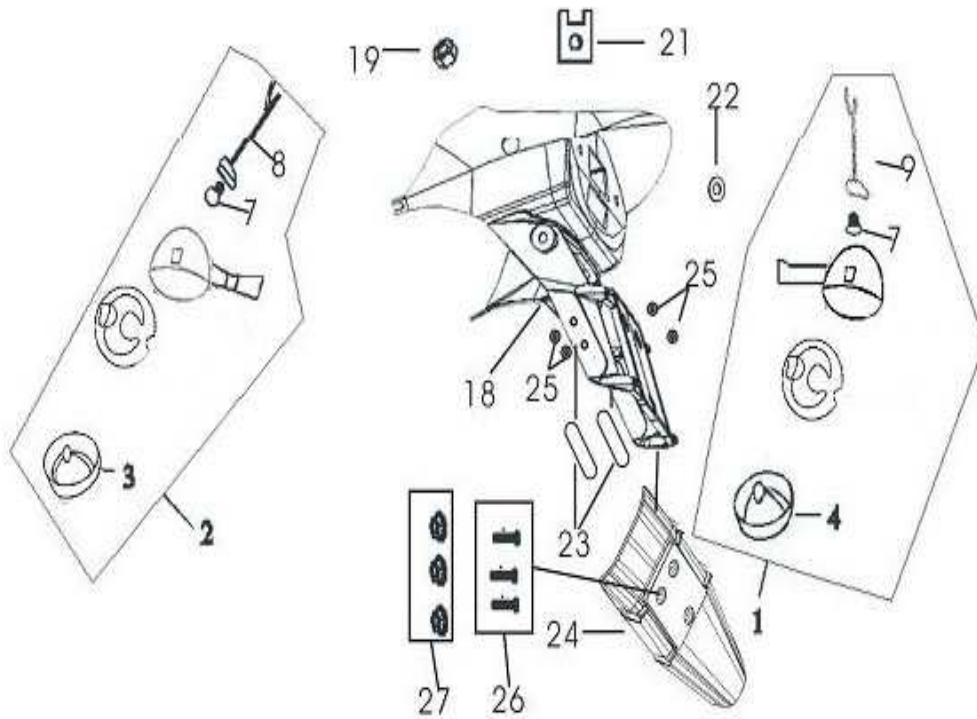
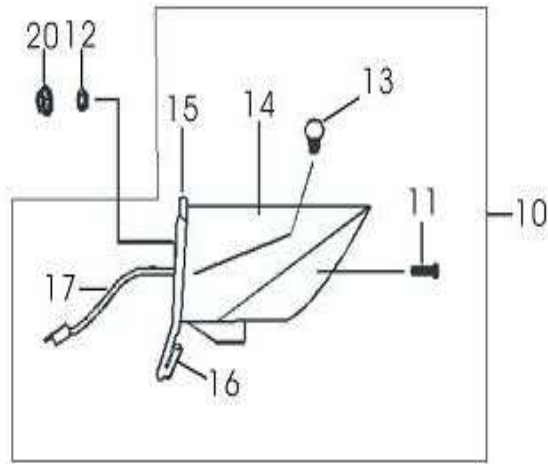

F18 TAIL LIGHT			
N0.	CODE	DESCRIPTION	QTY
1	Q0F16023000	REAR FLASHER LIGHT COMP LEFT	1
2	Q0F16024000	REAR FLASHER LIGHT COMP RIGHT	1
3	Q0C16024030	LIGHT COVER, R.	1
4	Q0C16023020	LIGHT COVER, L.	1
7	Q0C16023090	BULB, 12V/10W	1
8	Q0C16023050	WIRE COMP.F. L. FLASHER	1
9	Q0C16024040	WIRE COMP.F. R. FLASHER	1
10	Q0C16032001	TAIL LIGHT COMP.	1
11	Q0C16031210	TAPPING SCREW 4X20	2
12	Q0C16031090	RUBBER WASHER	3
13	Q0C16031060	BULB 12V 21/5W	1
14	Q0C16031021	INDICATOR LENS	1
15	Q0C16031050	TAIL LIGHT BASE	1
16	Q0C16062010	REFLECTOR	1
17	Q0C16031040	WIRE COMP.TAIL LIGHT	1
18	Q0F04030010	LICENSE BRACKET	1
19	B04221000040100	NUT M10X1.25(GOLD COLORED)	2
20	B04070600043000	FLANGE NUT M6(GOLD COLORED)	3
21	B04514200003000	SPRING NUT 4.2MM	2
22	B07030001002000	WASHER 10	2
23	Q0C16061001	REAR REFLECTOR	2
24	Q0F04050320000	LOWER LICENCE BRACKET (NEW PICTURE)	1
25	B04510000430000	SELF SECURING RINGS	4
26	B13060501665000	TAPPING SCREW M5X16	3
27	B04170500042000	NUT M5(GOLD COLORED)	3

F19 ELECTRICAL EQUIPMENT ASSY.1

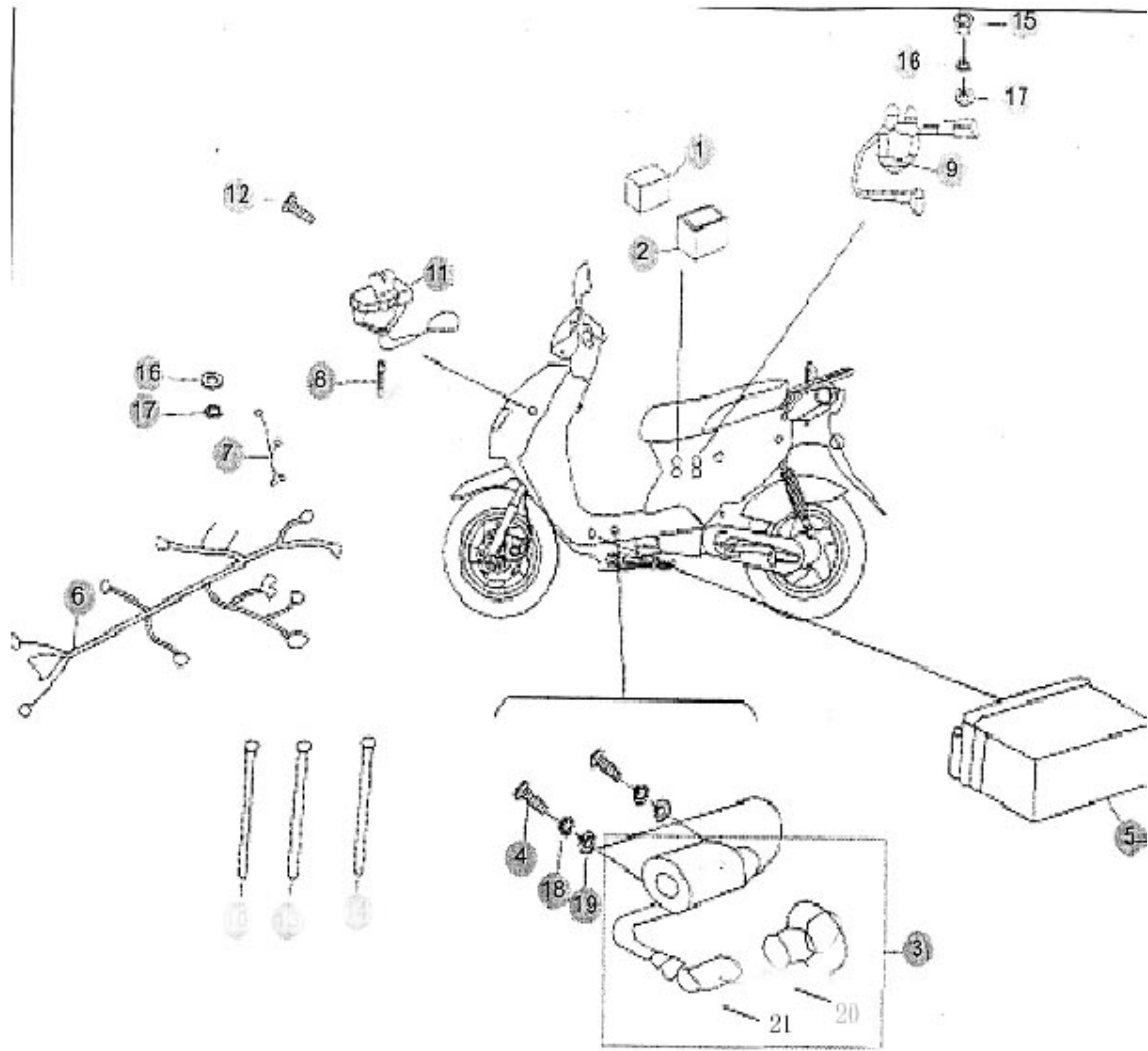

F19 ELECTRICAL EQUIPMENT ASSY.1			
NO.	CODE	DESCRIPTION	QTY.
1	Q0C15044020	C.D.I. UNIT COMP.	1
2	Q0C15044010	CUSHION. C.D.I	1
3	Q0C15042001	IGNITION COIL ASY	1
4	B02000502020100	HEX. 5×20	1
5	Q0C15031000	BATTERY ASSY.	1
6	Q0C15051000	WIRE HARNESS ASSY.	1
7	Q0C15055000	WIRE HARNESS	1
8	Q0C15050060	FUSE 7A	1
9	Q0C15041000	STARTER RELAY COMP.	1
11	Q0C15048000	RESISTOR COMP.	1
12	B01090601220100	PAN HEAD SCREW 6×12MM	1
15	B04000600023000	NUT 6MM(GOLD COLORED)	1
16	B07000000602000	WASHER 6MM	2
17	B07030000602000	WASHER 6MM	2
18	B07030000502000	WASHER 5MM	2
19	B07030000500	WASHER 5MM	2
21	Q0C15042000	SPARK PLUG CONNECTOR.	1

F20 ELECTRICAL EQUIPMENT

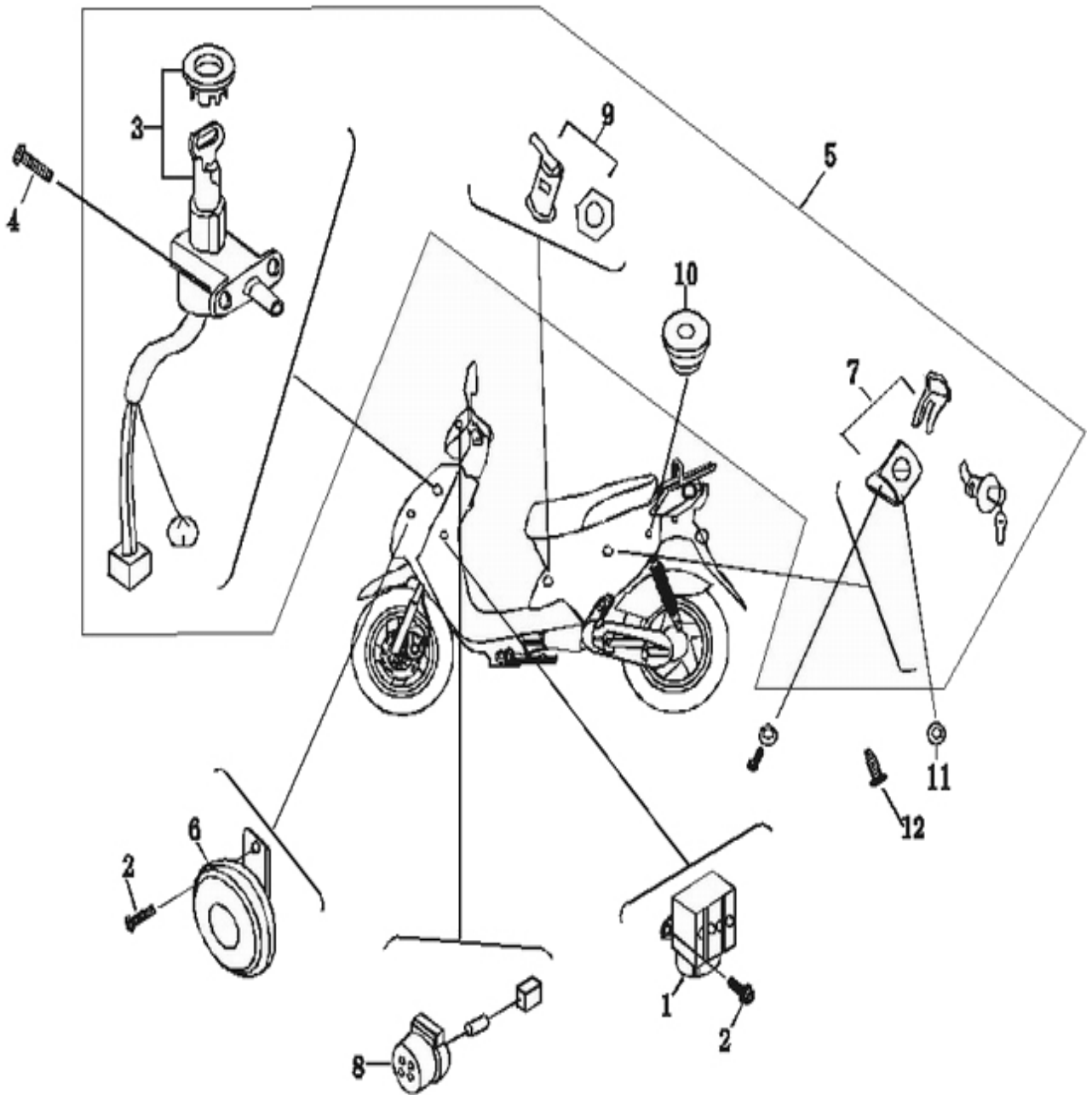

F20 ELECTRICAL EQUIPMENT			
NO.	CODE	DESCRIPTION	QTY.
1	Q0C15045010	REGULATOR COMP.	1
2	B01090601265000	BOLT 6×12 (BLACK	1
3	Q0C15061000	MAIN SWITCH ASSY.	1
4	Q0C15061040	BOLT 6×16	2
5	Q0C15060000	LOCK ASSY	1
6	Q0C15021000	HORN	1
7	B01090601265000	BOLT 6×12 (BLACK	1
8	Q0C15043010	FLASH & AUDIO PILOT CMF	1
9	Q0C15074000	LOCK, SIDE COVER	1
10	Q0C11021000	LOCK ASSY., FUEL TANK	1
11	Q0C15064010	LOCK ASSY. , SEAT	1
12	B05004200805000	TAPPING SCREW 4.2×8 (BLACK	2

F21 MUFFLER

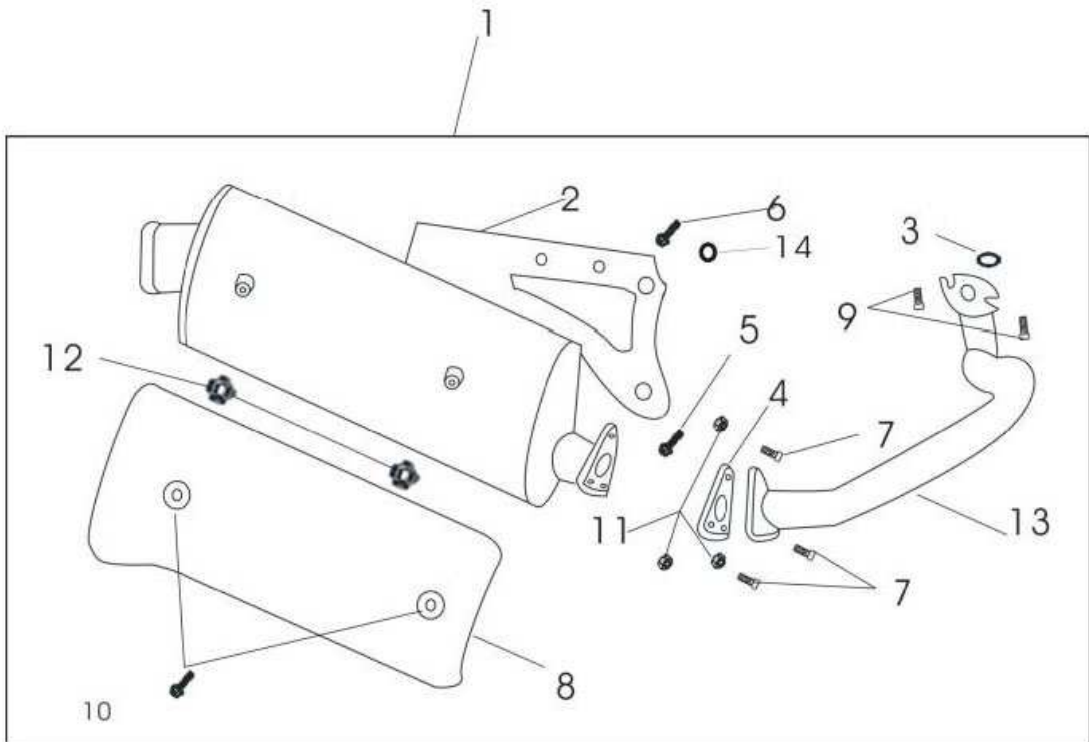

F21 MUFLER			
N0.	CODE	DESCRIPTION	QTY
1	Q0F02011000	MUFFLER ASSY.	1
2	Q0C02060001	MOUNTING PLATE	1
3	Q0C02070040	GROMMET, EXHAUST PIPE	1
4	Q0C02010020	GASKET, FLANGE	1
5	B01090802040100	FLANGE BOLT 8×20 (BLACK)	1
6	B01090803540100	FLANGE BOLT 8×35 (BLACK)	1
7	B01090602540100	SCREW 6×25	3
8	Q0F02011090	MUFFLER .COVER	1
9	B01090601640100	BOLT 6×16(BLACK)	2
10	B02000601020100	SCREW 6X10	2
11	B04070600020100	NUT M6	3
12	Q0F02011010	HEAT INSULATION WASHER	2
13	Q0F0212000	MANIFOLD	1

F22 TOOL KIT

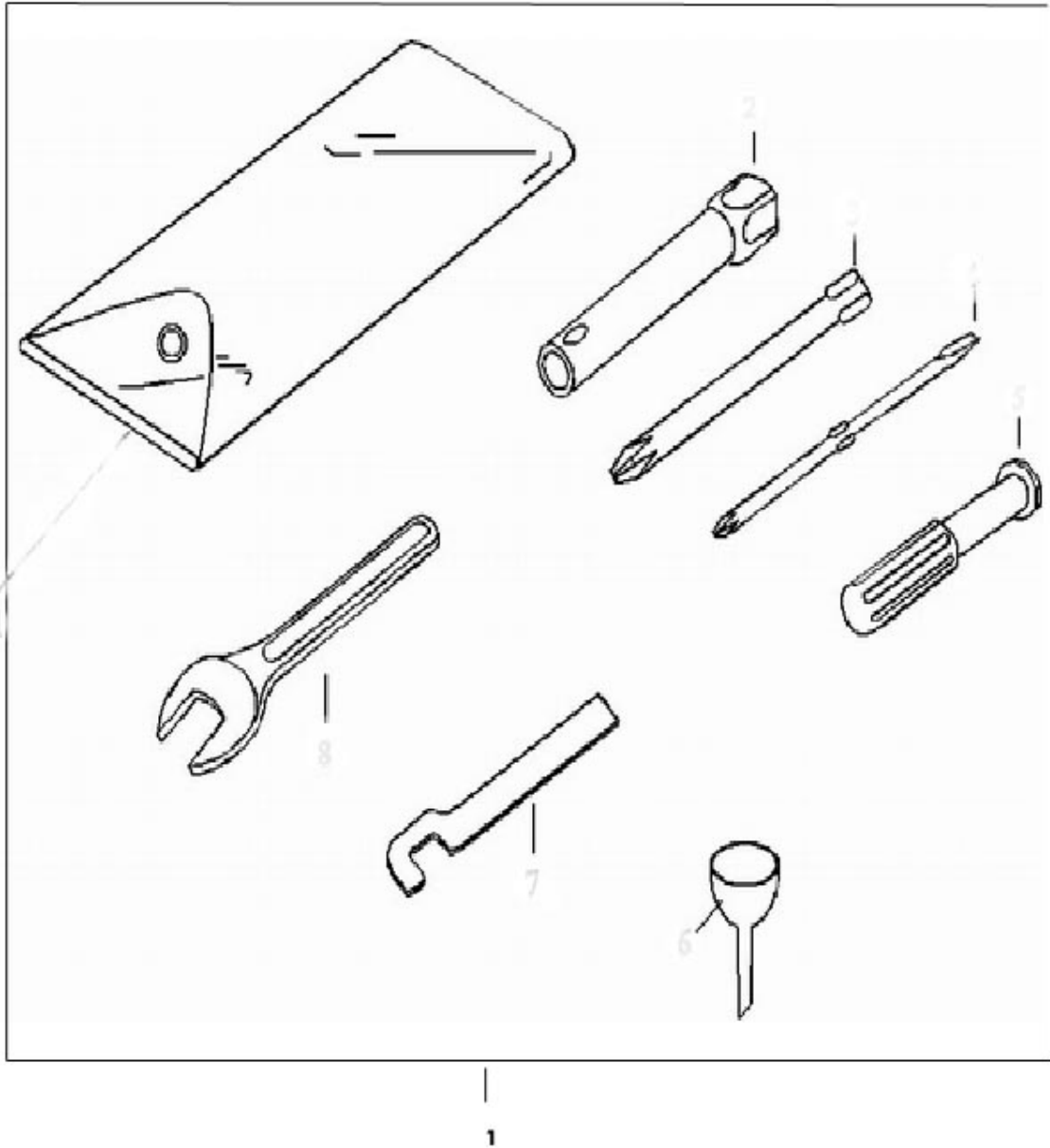

F22 TOOL KIT			
NO.	CODE	DESCRIPTION	QTY.
1	Q0C19000130	TOOL KIT	1

F23 ENGINE ATTACHMENT

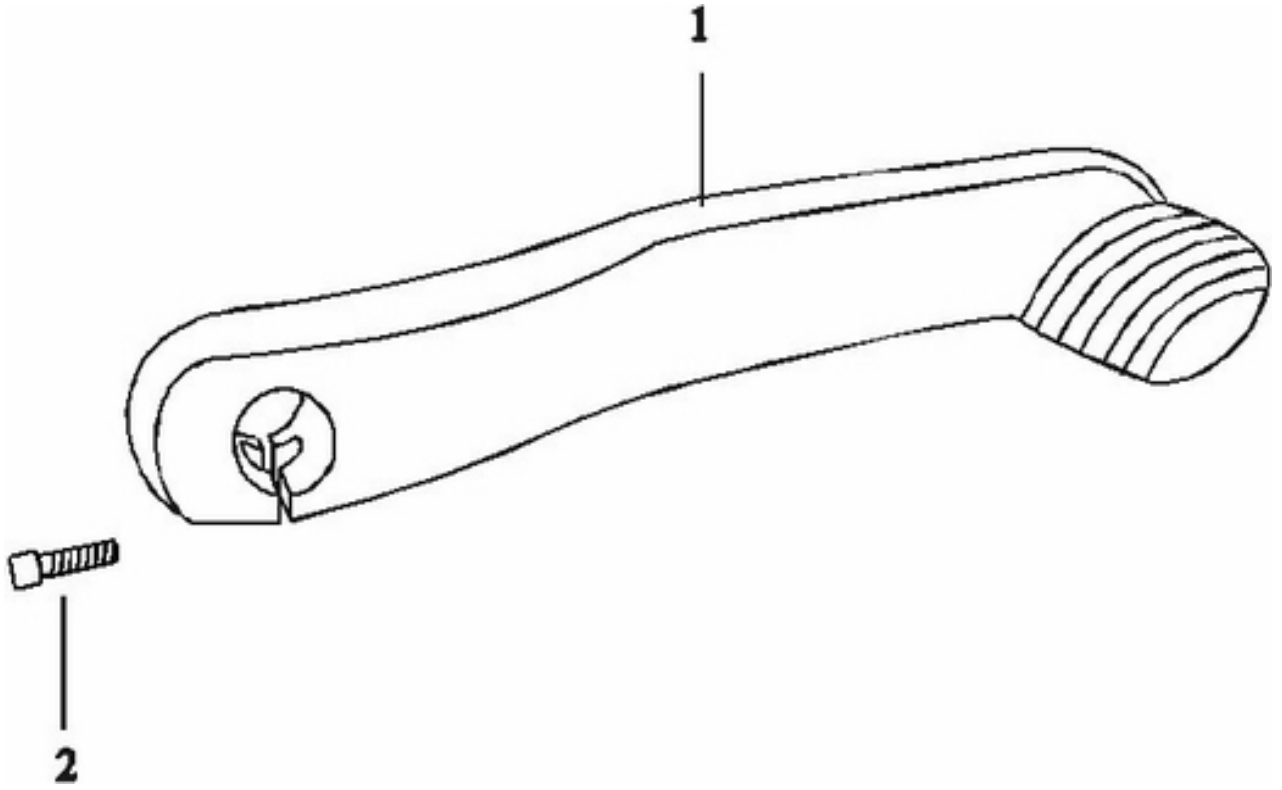

F23 ENGINE ATTACHMENT			
NO.	CODE	DESCRIPTION	QTY.
1	Q0C01082050	STARTING SHAFT (SILVER)	1
2	B02050602563000	SCREW 6X25	1

F24 FRONT FENDER

GRAFIC A

CPI
L'ASSISTENZA

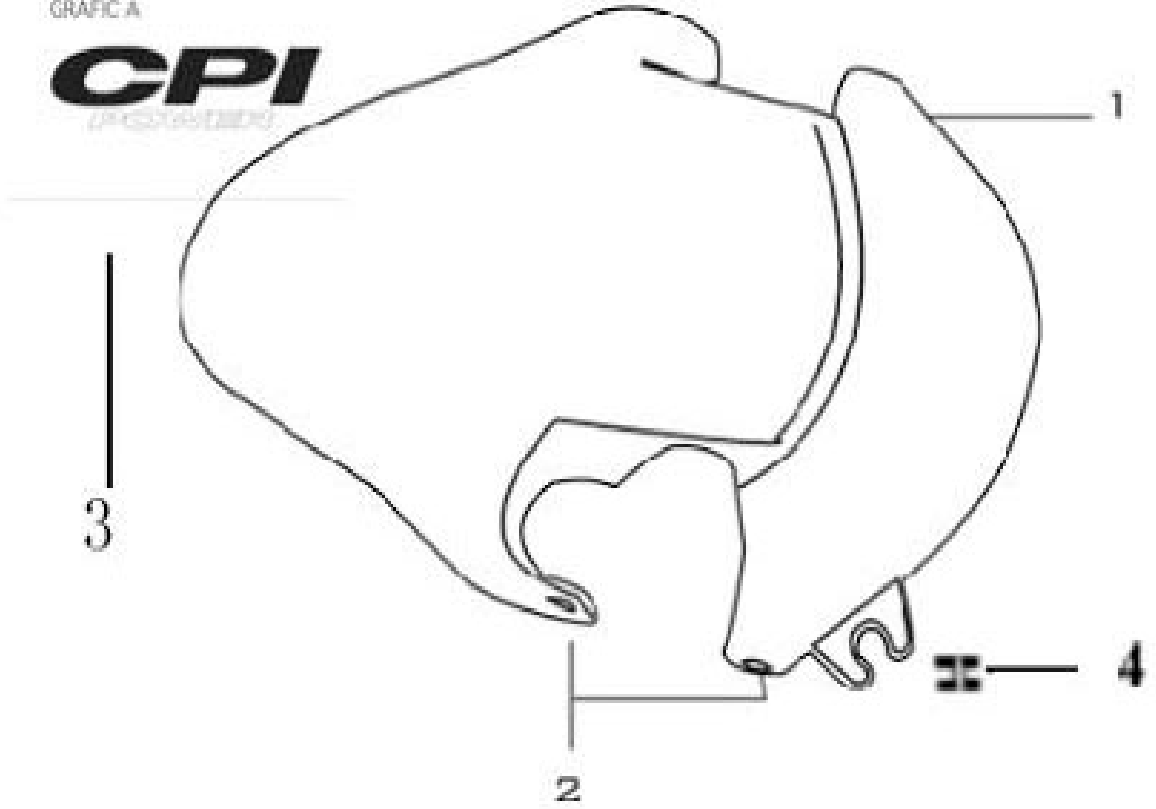

F24 FRONT FENDER			
NO.	CODE	DESCRIPTION	QTY
1	Q0FO40400110048	FRONT FENDER	1
2	B04070600020100	FLANGE NUT 6MM (BLACK)	4
3	Q0F18020210	"CPI POWER" STICKER FOR FRONT FENDER	1
4	Q0F04040040	WASHER	1