

**FRAMM
CPI**

B22-40000-00-09

930602

F1

FRAME ASSY.

GTR50

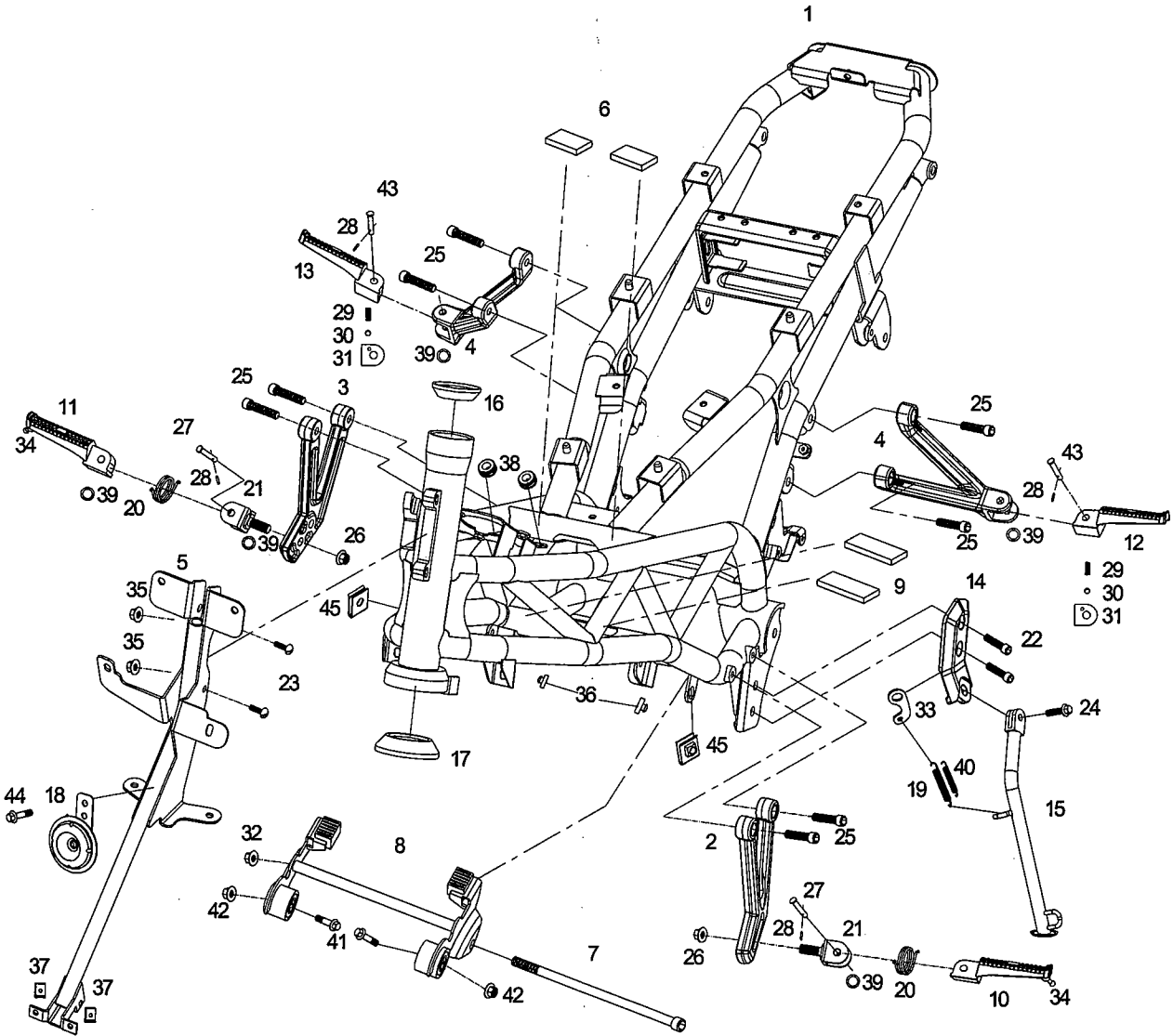

F1

FRAME ASSY

NO.	PART NO.	DESCRIPTION	REQD. NO.	
			GTR-50	
1		FRAME COMP.	1	
2	B22-49552-00-78	FRONT FOOTREST BRAKCR,1	1	
3	B22-49562-00-78	FRONT FOOTREST BRAKCR,2	1	
4	B22-49320-00-78	REAR FOOTREST BRACKET	2	
5	B22-42111-00-00	LEG SHIELD, 1 STAY	1	
6	B22-42157-00-00	DAMPER,2	2	
7	B22-42181-00-00	E/G MOUNTING BOLT,1	1	
8	B22-48610-00-00	E/G BRKT ASSY.	1	
9	B22-42159-00-00	DAMPER,4	2	
10	B22-49551-00-78	FL.FOOTREST	1	
11	B22-49561-00-78	RL. FOOTREST	1	
12	B22-49310-00-78	LH.REAR FOOTREST	1	
13	B22-49410-00-78	RH.REAR FOOTREST	1	
14	B22-49268-00-68	BRACKET	1	
15	B22-49210-00-68	SIDE STAND COMP.	1	
16	B22-47012-00-00	BALL RACE,2	1	
17	B22-47013-00-00	BALL RACE,3	1	
18	B22-28210-00-00	HORN	1	
19	B22-49255-10-00	TENSION SPRING,1	1	
20	B22-49574-00-00	SPRING	2	
21	B22-49553-20-00	FL. FOOTREST BRAKCR,2	2	
22	S-6700-08025-04	SOCKET BOLT/w 8*25	2	
23	S-5800-06025-04	FLANGE BOLT 6X25	2	
24	B22-49261-10-00	HEX BOLT	1	
25	S-6700-08022-03	SOCKET BOLT 8*22	8	
26	S-4012-10000-03	U NUT M10*1.5	2	
27	B22-49575-00-00	PIN	2	
28	S-4201-18213-03	SPLIT PIN 1.8X21.3	4	
29	B22-49357-00-00	SPRING	2	
30	S-6211-22000-00	STEEL BALL 1/4"	2	
31	B22-49359-00-00	PLATE	2	
32	S-4061-12000-03	FLANGE U NUT 12MM	1	
33	B22-49258-10-00	HOOK	1	
34	B22-49589-00-78	BOLT	1	

35	S-4050-06000-04	FLANGE NUT 6MM	2	
36	B22-42156-00-00	DAMPER,1	2	
37	B01-63577-00-00	SPRING NUT	2	
38	B22-42158-00-00	DAMPER,3	2	
39	B22-49525-00-00	WASHER	4	
40	B22-49256-00-00	TENSION SPRING,2	1	
41	B22-42191-00-04	E/G MOUNTING BOLT,2	2	
42	S-4061-10000-04	FLANGE U NUT 10MM	2	
43	B22-49355-00-00	PIN	2	
44	S-5800-06012-02	FLANGE BOLT 6*12	1	
45	B01-63193-00-00	SPEED NUT	2	

F2

FORNT WHEEL

GTR50

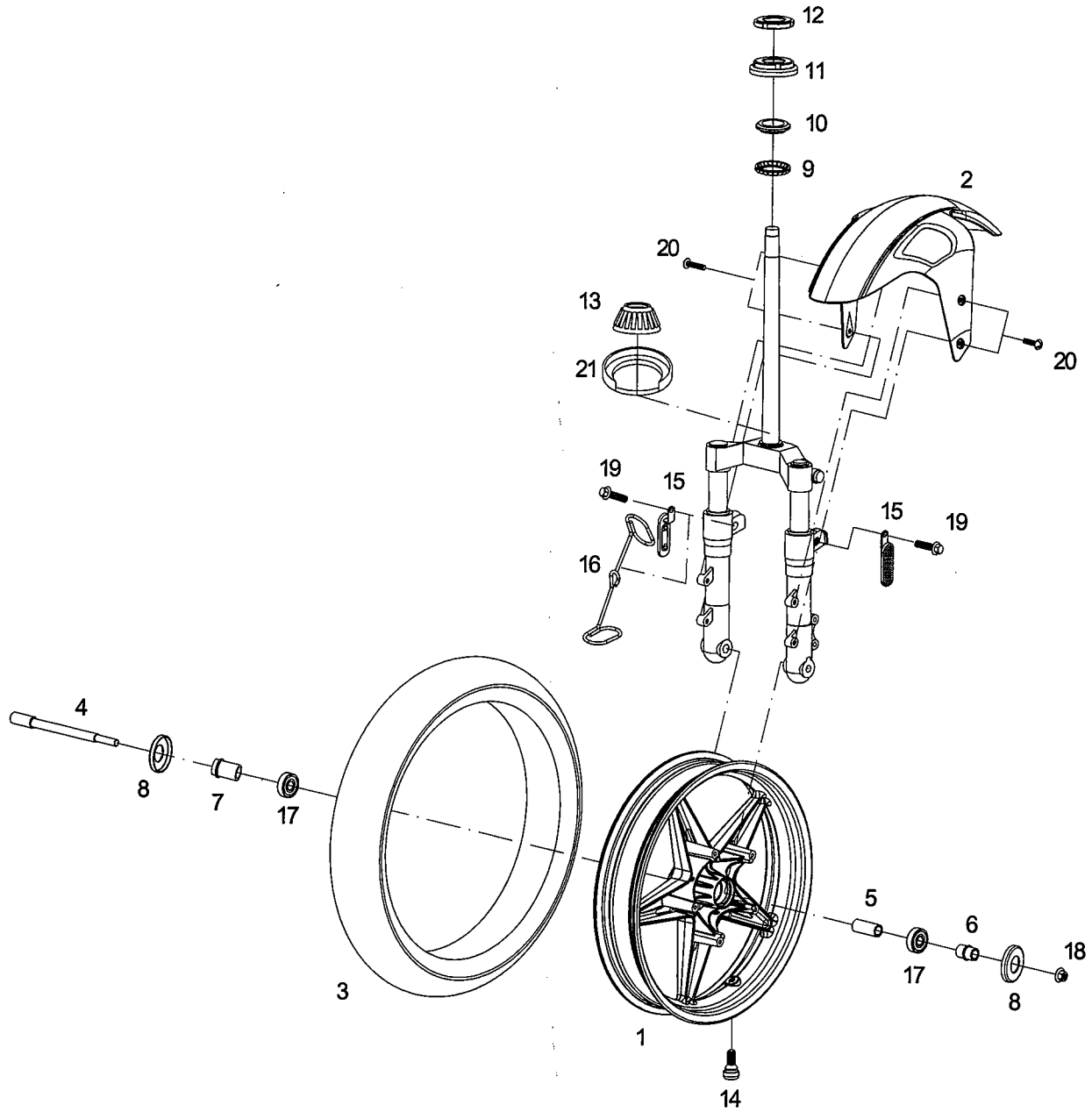

F2

FRONT WHEEL&FORK

NO.	PART NO.	DESCRIPTION	REQD. NO.	
			GTR-50	
1		FRONT RIM 17*3.0	1	
2	B22-64111-10-12	FRONT FENDER	1	RED
	B22-64111-10-20			YELLOW
	B22-64111-10-4D			BLUE
	B22-64111-10-63			BLACK
3	B22-43311-00-00	TIRE 110/70-17	1	
4	B22-43511-00-00	FR. WHEEL AXLE	1	
5	B22-43273-00-00	COLLAR	1	
6	B22-43275-00-00	FLANGE SPACE	1	
7	B22-43264-00-00	DISTANCE COLLAR COMP.	1	
8	B22-43278-00-00	COVER	2	
9	B22-47007-00-00	BALL SET	1	
10	B22-47011-00-00	BALL RACE,1	1	
11	B22-47042-00-00	NUT,1	1	
12	B22-47044-00-00	NUT,2	1	
13	B22-47174-00-00	BEARING	1	
14	B11-43322-00-00	RIM VALVE	1	
15	B22-25845-00-00	SIDE REFLEX REFLECT	2	
16	B22-45477-00-00	WIRE CLIP	1	
17	S-6120-06302-00	BALL BEARING	2	
18	S-4061-12000-03	FLANGE U NUT 12mm	1	
19	S-3500-06010-03	PAN HEAD SCREW 6X10	2	
20	S-3530-06010-02	PAN HEAD SCREW 6X10	4	
21	B22-47045-00-00	BERAING COVER	1	

F3

FORNT COVER,1

GTR50

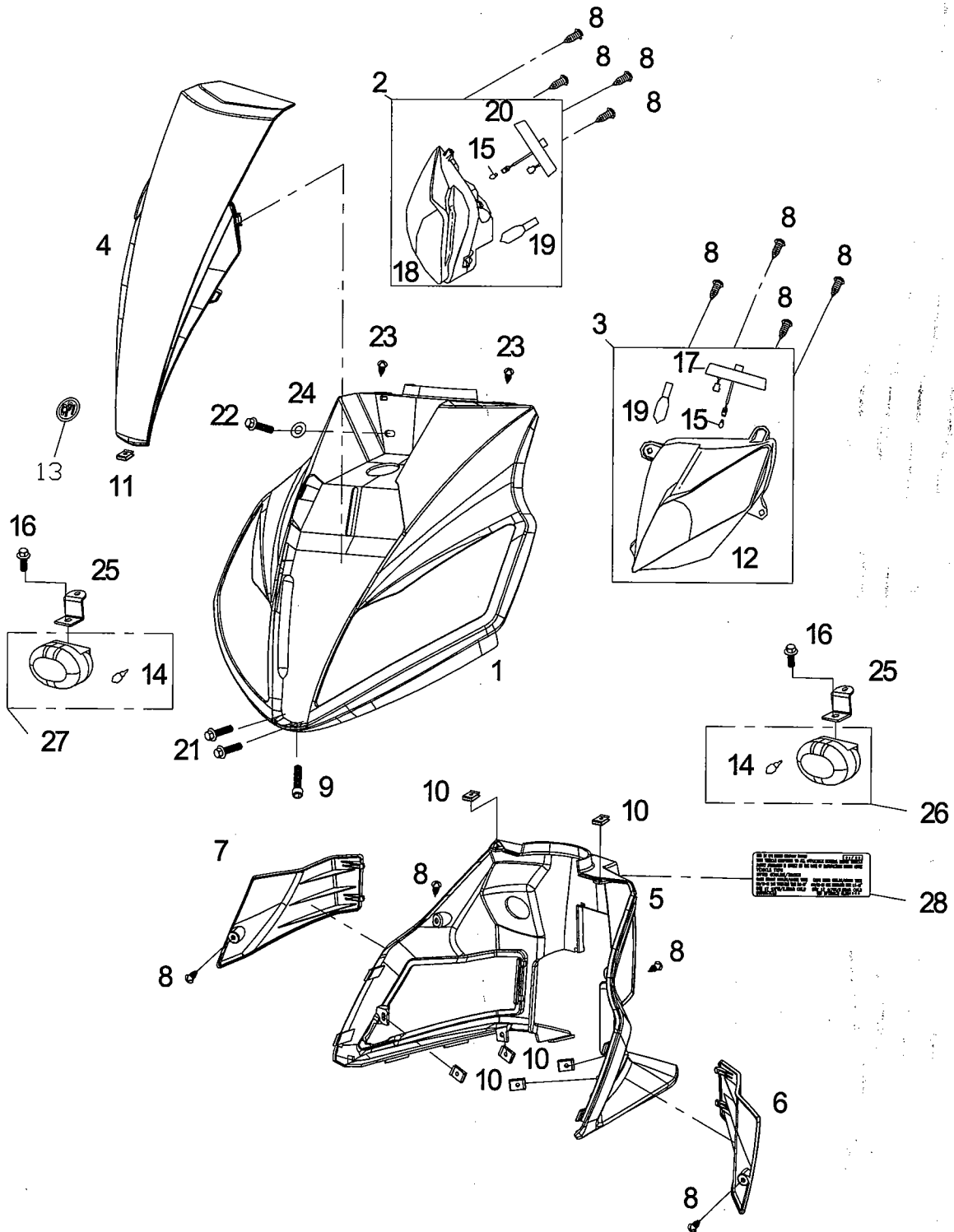

F3

FRONT COVER,1

NO.	PART NO.	DESCRIPTION	REQD. NO.	
			GTR-50	
1	B22-63111-00-12	LEG SHIELD,1	1	RED
	B22-63111-00-20			YELLOW
	B22-63111-00-4D			BLUE
	B22-63111-00-63			BLACK
2		HEAD LIGHT ASSY.,2	1	
3		HEAD LIGHT ASSY.,1	1	
4	B22-63119-10-67	COVER,1	1	
5	B22-63121-00-67	LEG SHIELD,2	1	
6	B22-63161-00-67	INSPEDT COVER,1	1	
7	B22-63171-00-67	INSPEDT COVER,2	1	
8	S-3900-05012-04	TAPPING SCREW 5*12	12	
9	S-6700-05016-03	SOCKET BOLT 5*16	1	
10	B01-63576-00-00	SPRING NUT 5MM	6	
11	B22-63577-00-00	CLIP NUT	1	
12	B22-25110-10-00	SHELL ASSY.,1	1	
13	F13-61113-00-00	C.P.I LOGO	1	
14		BULB 12V-16W	2	
15	B22-25351-10-00	BULB 12V-5W	2	
16		BOLT W/WASHER 5X16	2	
17		SOCKET CORD ASSY.,1	1	
18	B22-25190-00-00	SHELL ASSY.,2	1	
19	B22-25153-10-00	DIPPED BEAM BULB	1	
20		SOCKET CORD ASSY.,2	1	
21	S-3454-05016-02	BOLT W/WASHER 5X16	2	
22	S-5800-06012-02	FLANGE BOLT 6*12	1	
23	S-3900-05016-04	TAPPING SCREW 5*16	2	
24	S-4101-06193-00	PLATE WASHER 6MM	1	
25		FLASHER LIGHT BRACKET	2	
26		FLASHER LIGHT ASSY. 2	1	
27		FLASHER LIGHT ASSY. 3	1	
28		DOT EMBLEM	1	

F4

REAR WHEEL/REAR FENDER

GTR50

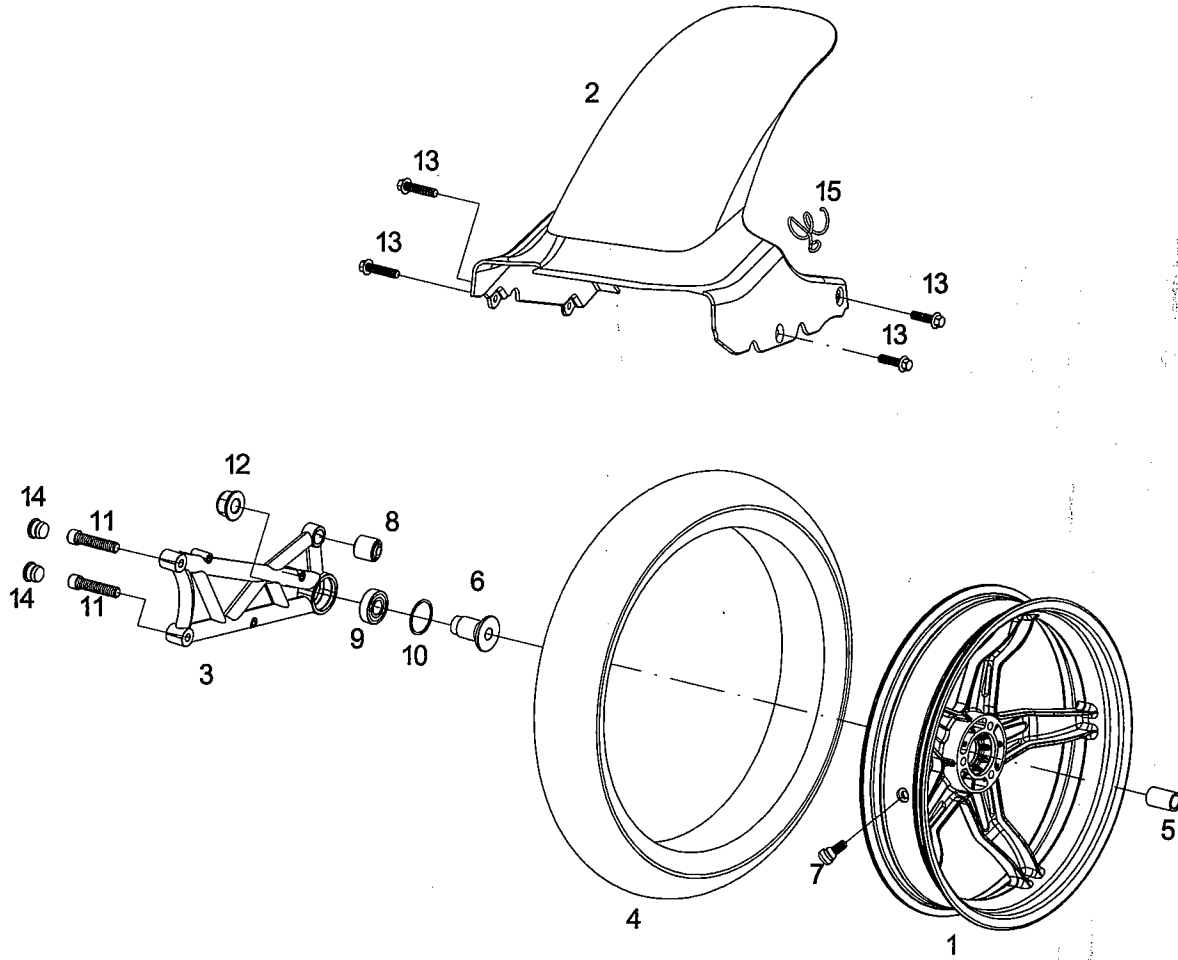

F4

REAR WHEEL/ REAR FENDER

NO.	PART NO.	DESCRIPTION	REQD. NO.	
			GTR-50	
1	B28-44210-00-B3	REAR RIM 17*3.5	1	
2	B22-64211-10-67	REAR FENDER,1	1	
3	B22-48231-00-69	R.R. SWING ARM1	1	
4	B22-44311-00-00	TIRE 130/60-17	1	
5	B22-44283-20-00	COLLAR,2	1	
6	B22-44273-00-00	COLLAR,1	1	
7	B11-43322-00-00	RIM VALVE	1	
8	61G-01223-00-00	ENG. HANGER RUB. BUSH	1	
9	S-6120-06005-40	BALL BEARING 6005LLUA	1	
10	S-4521-17500-00	CIR-CLIP 50*1.7	1	
11	S-6700-08025-04	SOCKET BOLT 8X25	2	
12	S-4061-16000-04	FLANGE U NUT 16MM	1	
13	S-5800-06012-04	FLANGE BOLT 6*12	4	
14	B22-48251-10-00	HOLD GAP	2	
15	B28-24133-10-00	CLIP	1	

F5

LEG SHIELD

GTR50

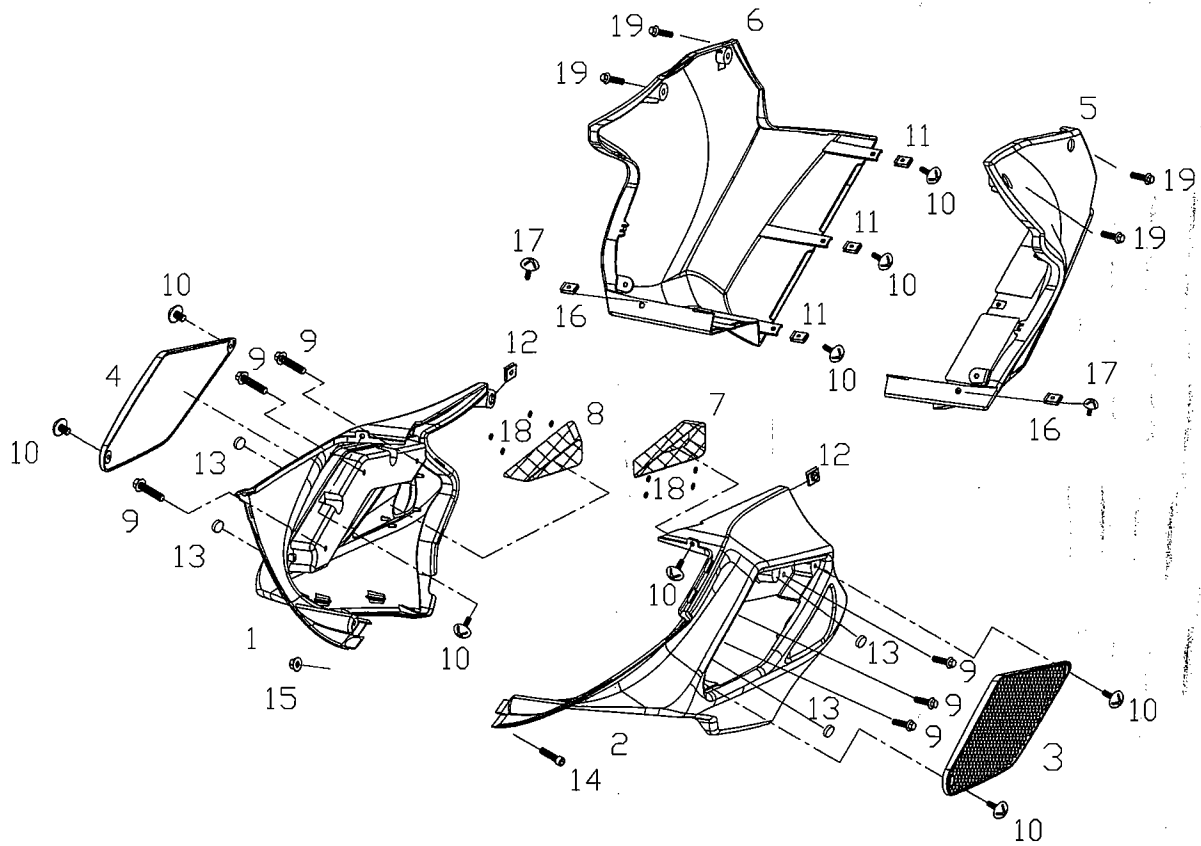

F5

LEG SHIELD

NO.	PART NO.	DESCRIPTION	REQD. NO.	
			GTR-50	
1	B22-63151-00-12	LEG SHIELD,4	1	RED
	B22-63151-00-20			YELLOW
	B22-63151-00-4D			BLUE
	B22-63151-00-63			BLACK
2	B22-63131-00-12	LEG SHIELD,3	1	RED
	B22-63131-00-20			YELLOW
	B22-63131-00-4D			BLUE
	B22-63131-00-63			BLACK
3	B22-63115-00-00	PROTECT,1	1	
4	B22-63116-00-00	PROTECT,2	1	
5	B22-63141-10-67	UNDER COVER,1	1	
6	B22-63142-10-67	UNDER COVER,2	1	
7	B22-63515-00-00	PROTECTOR,3	1	
8	B22-63516-00-00	PROTECTOR,4	1	
9	S-5800-06012-02	FLANGE BOLT 6*12	6	
10	S-3900-05012-04	TAPPING SCREW 5*12	9	
11	B01-63576-00-00	SPRING UNT 5MM	3	
12	B01-63193-00-00	SPEED NUT	2	
13	B22-63132-00-00	DAMPER	4	
14	S-6701-06035-03	SOCKET BOLT 6*35	1	
15	S-4001-06000-03	HEX.NUT 6MM	1	
16	B03-63576-00-00	SPRING NUT 4MM	2	
17	S-3900-05016-04	TAPPING SCREW 5*16	2	
18	B03-62319-00-00	SPEED NUT	10	
19	S-5800-06016-01	FLANGE BOLT 6*16	4	

F6

REAR SHOCK ABSORBER

GTR50

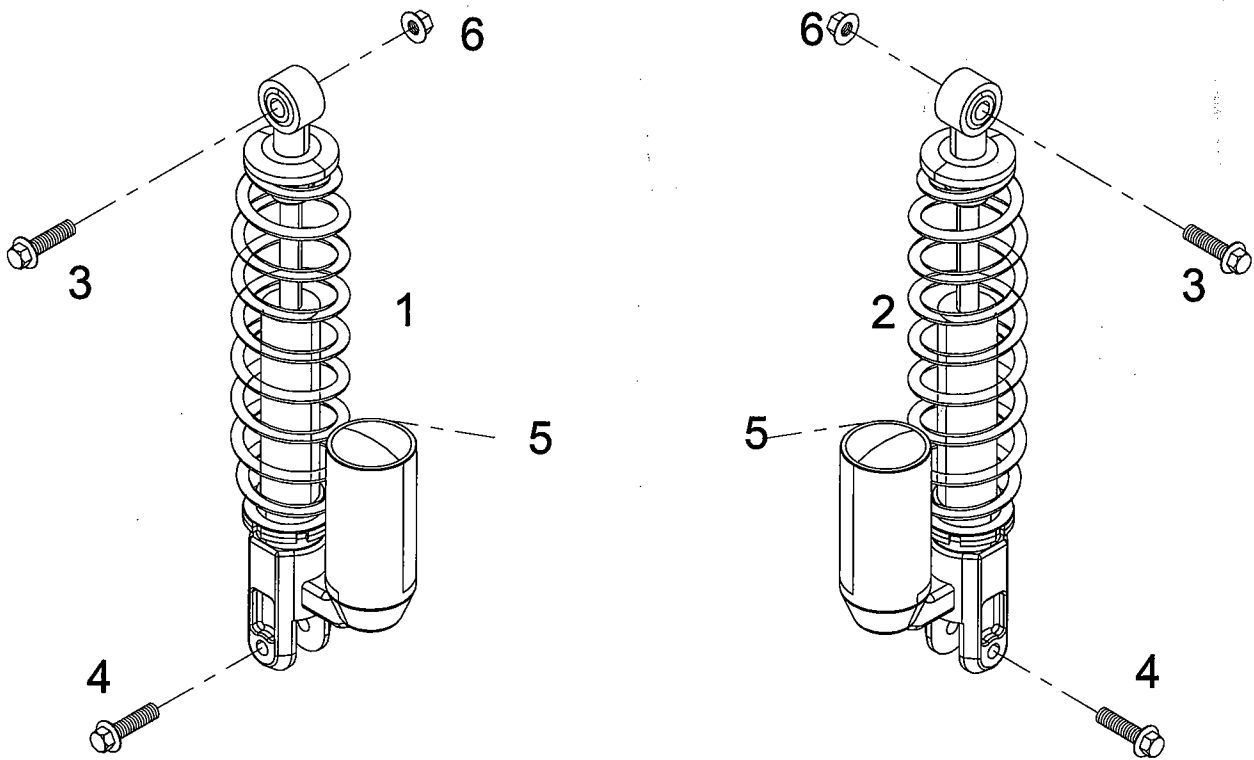

F6**REAR SHOCK ABSORBER**

NO.	PART NO.	DESCRIPTION	REQD. NO.	
			GTR-50	
1	B22-48210-00-00	R.R. SHOCK ABSORBER,1	1	
2	B22-48220-00-00	R.R. SHOCK ABSORBER,2	1	
3	S-5801-10040-04	FLANGE BOLT 10*40	2	
4	S-5801-08040-04	FLANGE BOLT 8*40	2	
5	B22-48216-00-00	CAP	2	
6	S-4061-10000-04	NUT LUCK 10MM	2	

F7

MUFFLER

GTR50

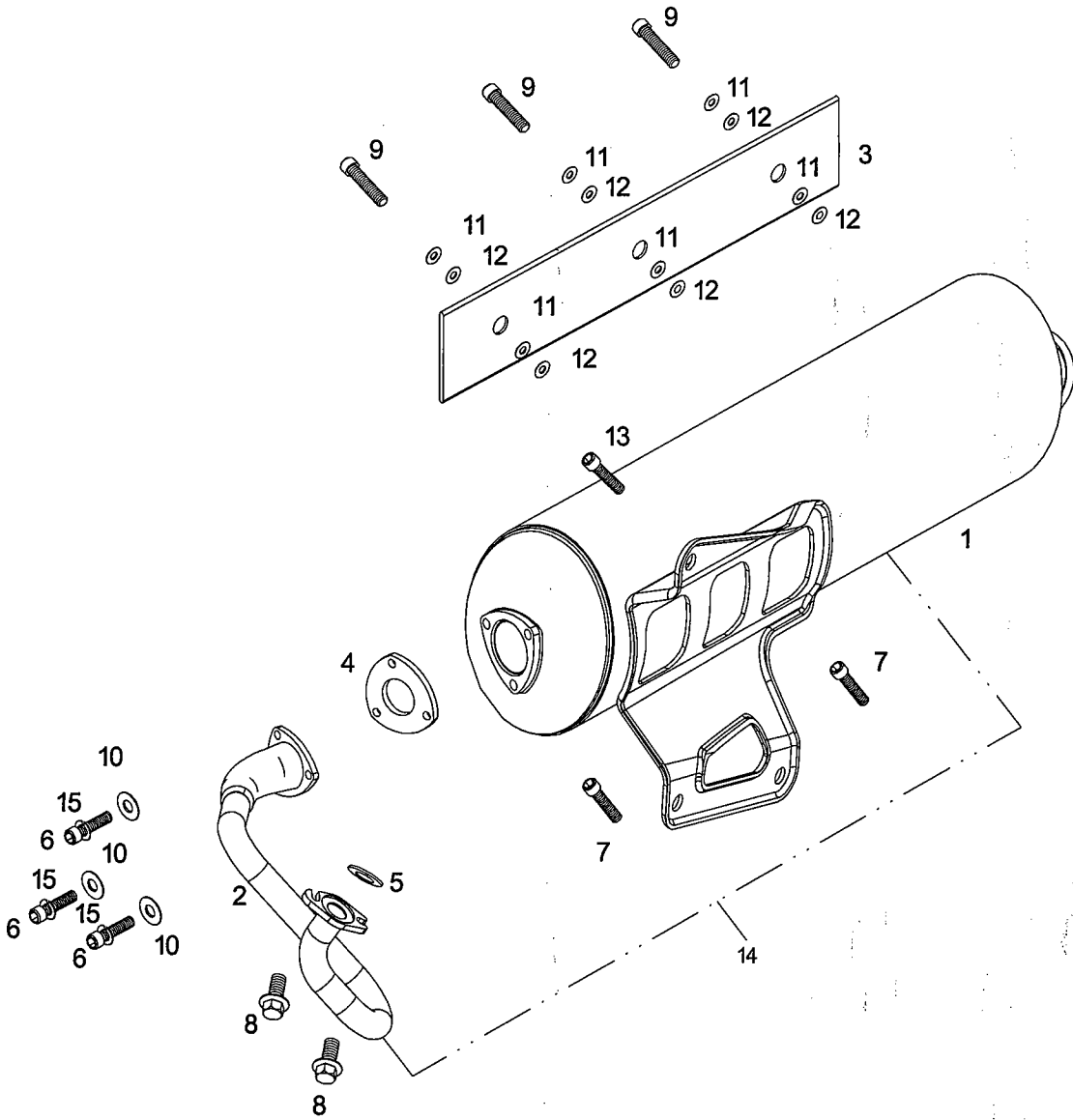

F7

MUFFLER

NO.	PART NO.	DESCRIPTION	REQD. NO.	
			GTR-50	
1	B28-18211-00-00	MUFFLER	1	45&30KM
	F13-18211-00-00		1	60&OPEN
2	B28-18201-00-00	EXHAUST MANIFOLD	1	45KM
	F25-18201-00-00		1	OPEN
	F26-18201-00-00		1	30KM
	F27-18201-00-00		1	60KM
3	B22-18111-00-00	MUFFLER PROTECTOR	1	
4	F02-18141-00-00	EXHAUST PIPE GASKET	1	
5	T01-18131-00-00	EXHAUST PIPE GASKET	1	
6	S-6700-06025-70	SCOKET BOLT M6X25	3	
7	S-5701-08035-01	FLANGE BOLT 8*35	2	
8	S-5810-06018-03	FLANGE BOLT 6X18	2	
9	S-6710-06012-70	SOCKET BOLT 6X12	3	
10	S-4101-06123-70	SPRING WASHER 6MM	3	
11	S-4101-06083-70	PLATE WASHER 6MM	6	
12	S-4101-06084-90	PLATE WASHER 6MM	6	
13	S-5800-08020-01	FLANGE BOLT 8*20	1	
14	B28-18200-00-00	EXHAUST PIPE ASSY	1	45KM
	F35-18200-00-00		1	30KM
	F36-18200-00-00		1	60KM
	F37-18200-00-00		1	OPEN
15	S-4111-06105-70	PLATE WASHER 6MM	3	

F8

SIDE COVER & TAIL LIGHT

GTR50

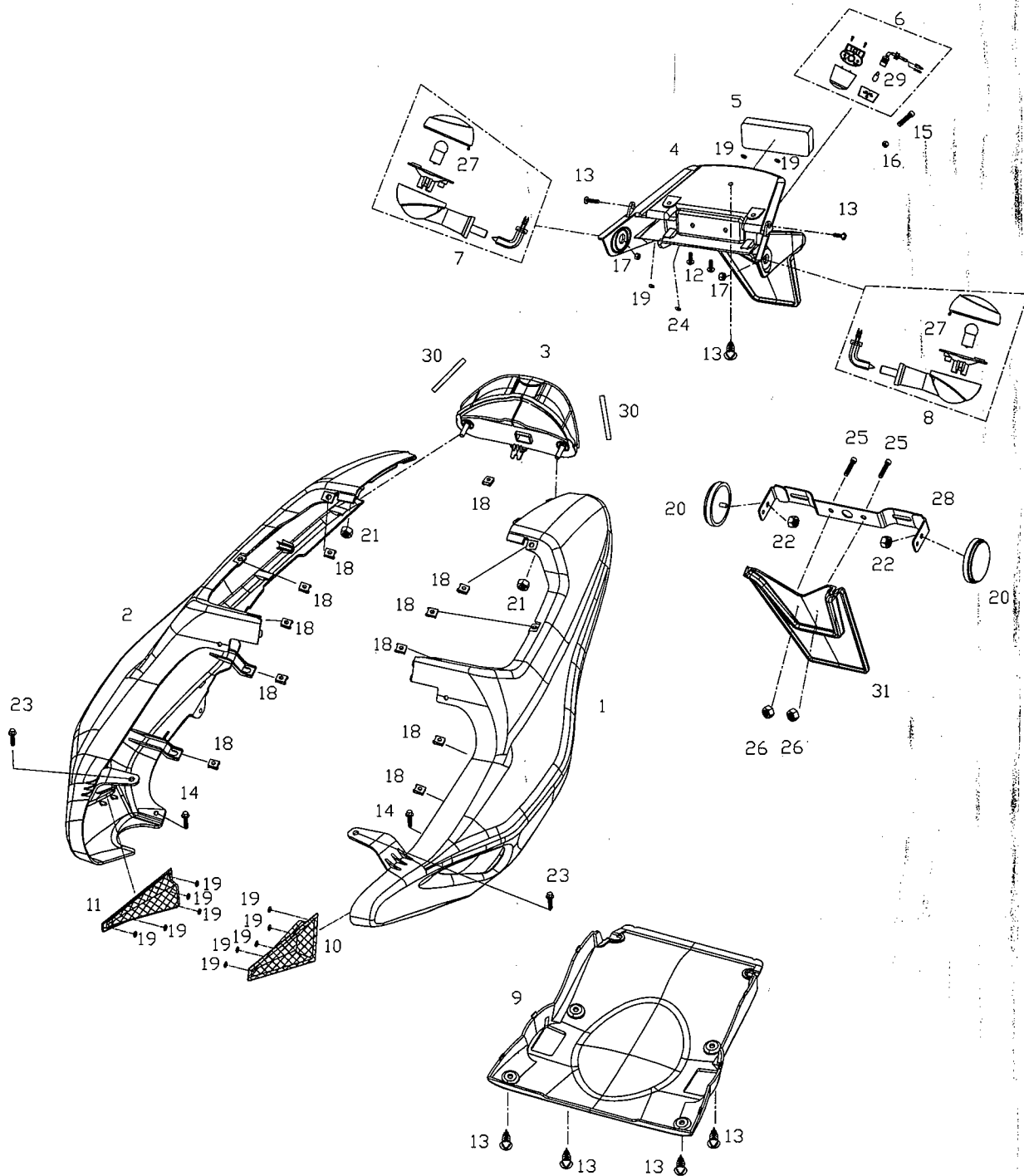

F8

SIDE COVER & TAIL LIGHT

NO.	PART NO.	DESCRIPTION	REQD. NO.	
			GTR-50	
1	B22-63511-00-12	SIDE COVER1	1	Red
	B22-63511-00-20		1	Yellow
	B22-63511-00-4D		1	BLUE
	B22-63511-00-63		1	BLACK
2	B22-63521-00-12	SIDE COVER2	1	Red
	B22-63521-00-20		1	Yellow
	B22-63521-00-4D		1	BLUE
	B22-63521-00-63		1	BLACK
3		TAIL LIGHT ASSY.	1	
4	B22-64251-00-67	LICENSE BRACKET	1	
5	B22-25427-00-00	RR. REFLECTOR	1	
6	B22-25710-00-00	LICENSE LIGHT ASSY.	1	
7		FLASHER LIGHT ASSY., 3	1	
8		FLASHER LIGHT ASSY., 4	1	
9	B22-64221-00-67	REAR FENDER, 2	1	
10	B22-63525-00-00	PROTECTOR, 5	1	
11	B22-63526-00-00	PROTECTOR, 6	1	
12	S-3894-05012-04	SCREW W/WASHER	2	
13	S-3900-05012-04	TAPPING SCREW 5*12	7	
14	S-5800-06012-02	FLANGE BOLT 6*12	2	
15	S-6700-05016-04	SOCKET BOLT 5*16	1	
16	S-4050-05000-04	FLANGE NUT 5MM	1	
17	S-4001-10000-03	NUT 10MM	2	
18	B01-63576-00-00	SPRING NUT 5MM	11	
19	B03-62319-00-00	SPEED NUT	13	
20		SIDE REFLEX REFLECT	2	
21	S-4050-06000-01	FLANGE NUT 6MM	2	
22	S-4050-05000-04	FLANGE NUT 5MM	2	
23	S-5800-06020-04	FLANGE BOLT 6*20	2	
24	B22-62319-00-00	SPEED NUT	1	
25	S-5800-06012-04	FLANGE BOLT 6*12	2	
26	S-4051-06000-01	FLANGE U NUT 6MM	2	
27		BULB 12V-10W	2	
28	B22-64255-00-00	LICENSE BRACKET	1	
29	B22-25351-10-00	BULB 12V-5W	1	

30	F01-63595-00-00	DAMPER	2	
31	B22-64281-10-67	ADAPTER PLATE	1	

F9

FUEL TANK

GTR50

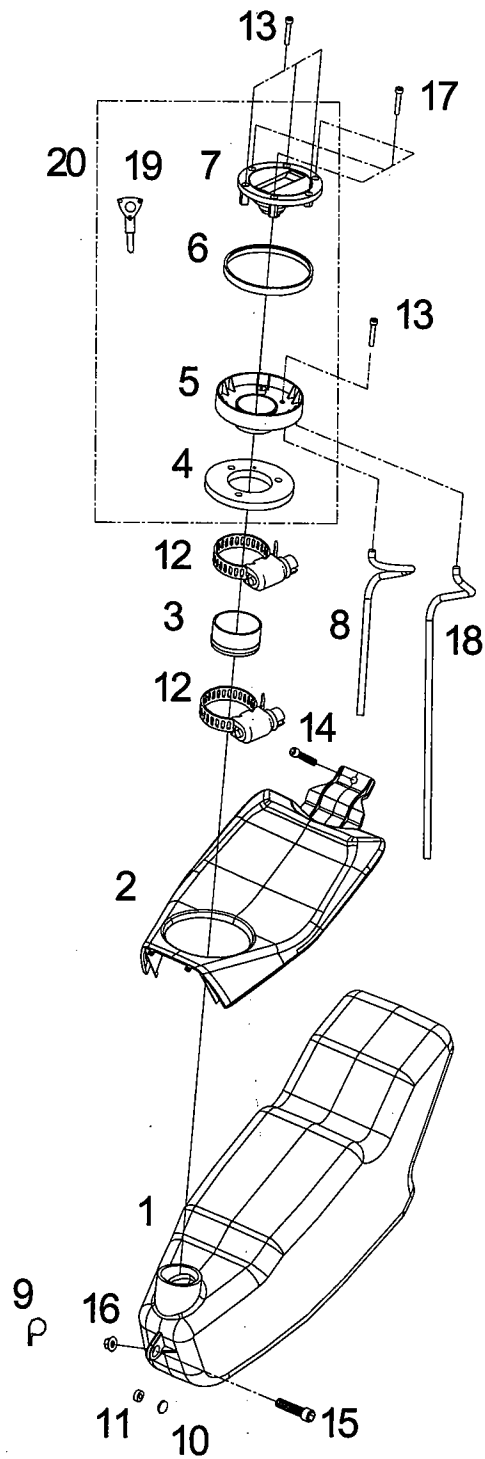

F9

FUEL TANK

NO.	PART NO.	DESCRIPTION	REQD. NO.	
			GTR-50	
1	B22-52110-10-00	FUEL TANK COMP.	1	
2	B22-52136-00-G0	TANK-COVER	1	
3	B22-52016-00-00	SEAL	1	
4	B25-56617-00-00	FUEL TANK LOCK BRAKET GASKET	1	
5	B25-56614-00-00	FUEL TANK LOCK BRAKET	7	
6	B22-56618-10-00	SEAL	1	
7	B22-56610-20-00	FUEL TANK LOCK ASSY.	1	
8	B22-56516-00-00	DRAIN HOSE	1	
9	B22-42273-00-00	CLAMP	1	
10	B22-52014-00-00	COLLAR	1	
11	B22-52015-00-00	GROMMET	1	
12	B22-52026-00-00	CLAMP 63mm	2	
13	S-6700-05016-70	SOCKET BOLT 5*16	4	
14	S-5800-06020-02	FLANGE BOLT 6*20	1	
15	S-5800-06025-02	FLANGE BOLT 6*25	1	
16	S-4050-06000-02	FLANGE NUT 6MM	1	
17	S-6701-05035-70	SOCKET BOLT 5*35	3	
18	B28-56516-00-00	FUEL HOSE	1	
19	B22-56271-20-00	KEY	2	
20	B22-56601-30-00	FUEL TANK LOCK SET	1	

F10

COOLING & RESERVE TANK

GTR50

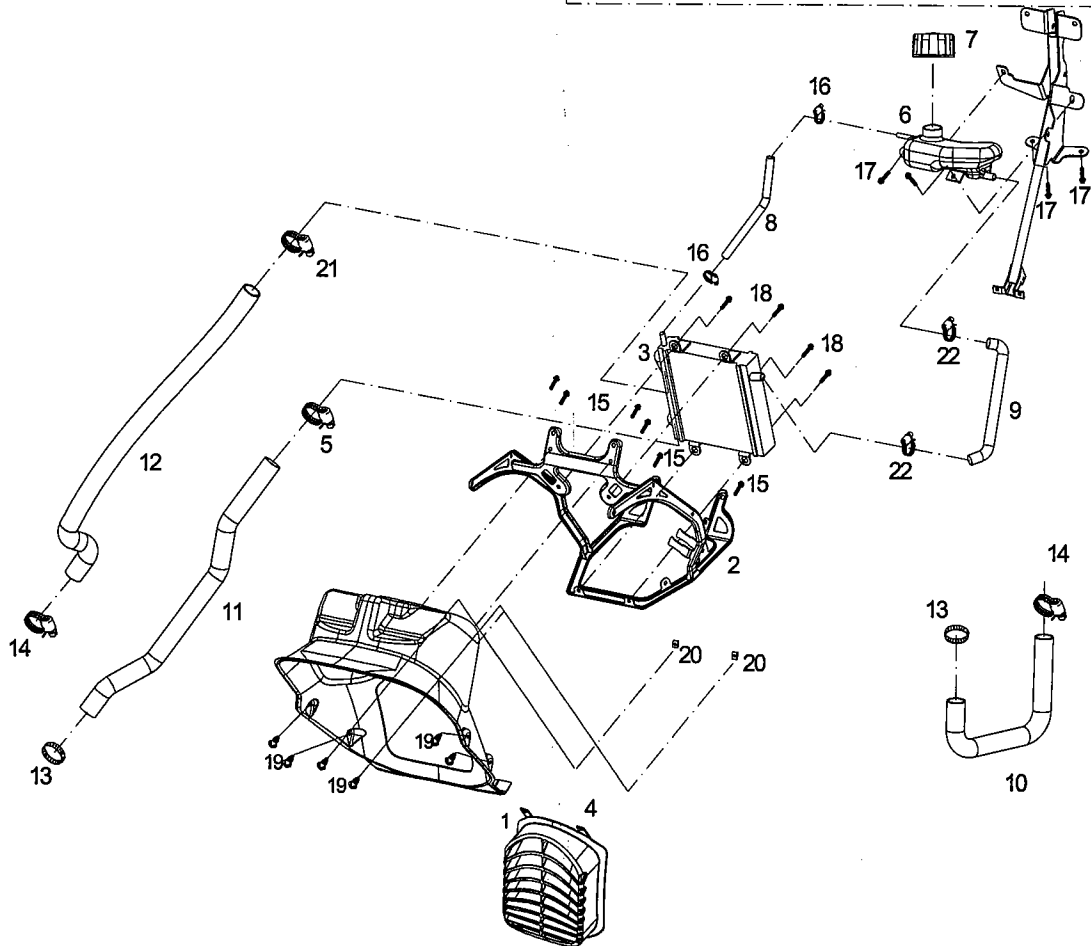
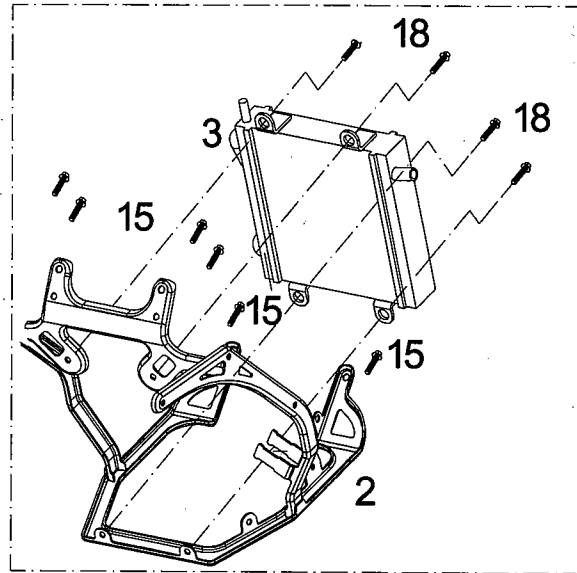
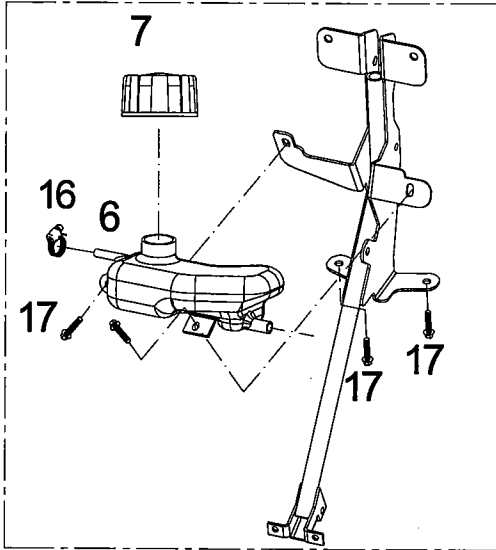

F10

COOLING & RESERVE TANK

NO.	PART NO.	DESCRIPTION	REQD. NO.	
			GTR-50	
1	B22-64115-00-12	INNER FENDER,1	1	Red
	B22-64115-00-20			yellow
	B22-64115-00-4D			BLUE
	B22-64115-00-63			BLACK
2	B22-42145-10-00	SUPFRAME BOTTOM	1	
3	64A-06500-00-00	COOLING SYSTEM	1	
4	B22-63145-10-00	COOLER COVER	1	
5	F01-06524-00-00	CLAMP	1	
6	B22-54011-00-00	RESERVE TANK	1	
7	B22-54012-00-00	RESERVE TANK CAP	1	
8	B22-54014-00-00	RESERVE TANK CAP HOSE,2	1	
9	B22-54013-10-00	RESERVE TANK CAP HOSE,1	1	
10	64A-06514-10-00	COOLING HOSES,3	1	
11	64A-06512-10-00	COOLING HOSES,1	1	
12	64A-06513-00-00	COOLING HOSES,2	1	
13	64A-06523-10-00	CLAMP	2	
14	64A-06524-00-00	CLAMP	2	
15	S-5800-06012-02	FLANGE BOLT 6X12	3	
16	B22-54016-00-00	CLAMP	2	
17	S-3454-05016-02	BOLT W/WASHER 5X16	4	
18	S-5800-06020-02	FLANGE BOLT 6X20	4	
19	S-3900-05012-04	TAPPING SCREW	6	
20	B01-63576-00-00	SPRING NUT	2	
21	64A-06525-00-00	CLAMP	1	
22	B28-54015-00-00	CLAMP17MM	2	

F11

HANDLE BAR & CABLE

GTR50

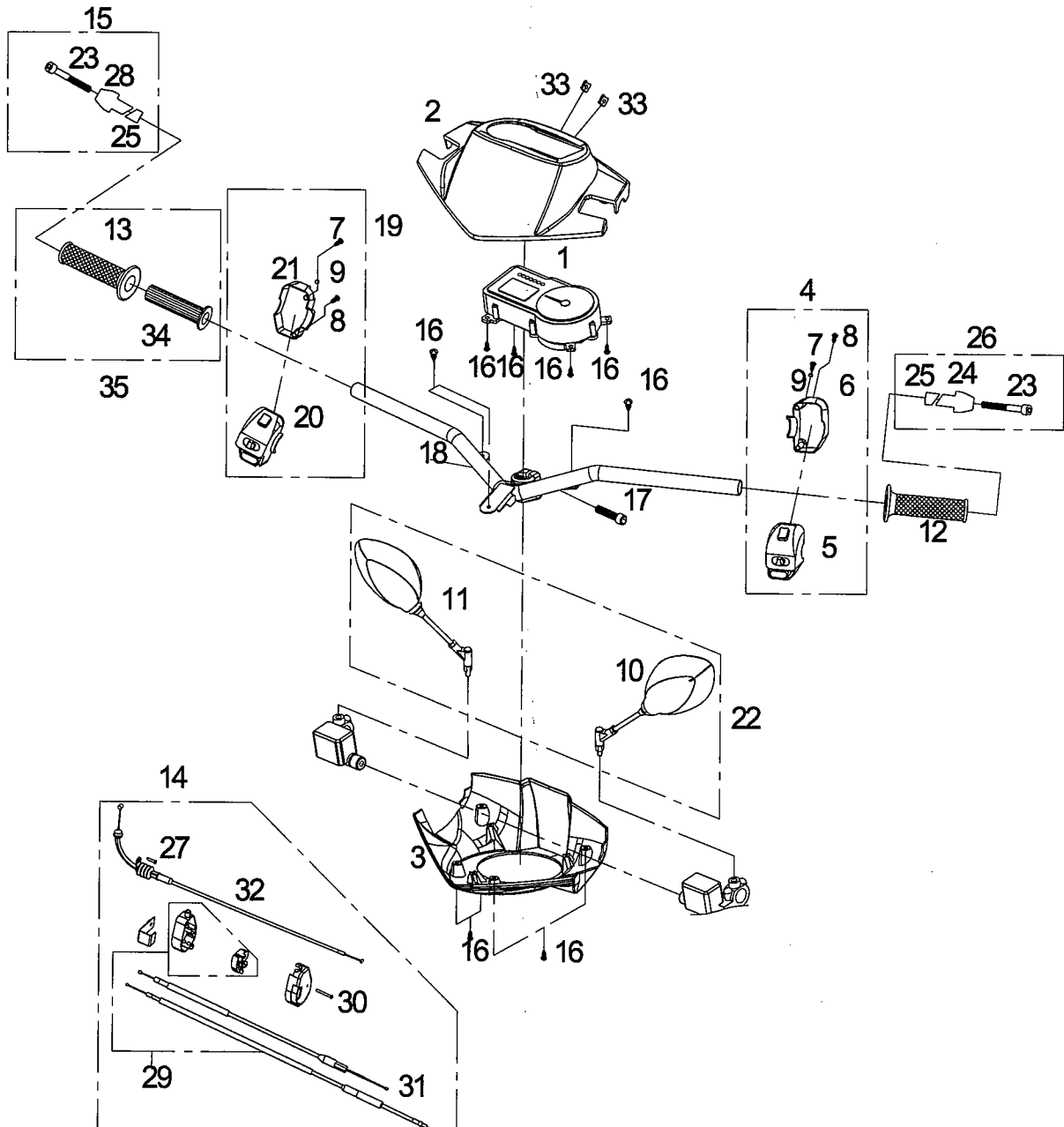

F11

HANDLE CABLE & COVER

NO.	PART NO.	DESCRIPTION	REQD. NO.	
			GTR-50	
1	B22-24110-30-00	SPEEDOMETER ASSY	1	
2	B22-62311-00-67	HANDLE BAR COVER,1	1	
3	B22-62321-00-67	HANDLE BAR COVER,2	1	
4	B22-27700-00-00	LEFT HANDLE SWITCH ASSY	1	
5	B22-27710-00-00	LEFT HANDLE SWITCH,1	1	
6	B22-27730-00-00	LEFT HANDLE SWITCH,2	1	
7	S-3500-05028-04	PAN HEAD SCREW5X28	2	
8	S-3500-05016-04	PAN HEAD SCREW5X16	2	
9	S-4101-05084-34	SPRING WASHER	2	
10	B28-62710-00-00	REAR VIEW MIRROR ASSY,1	1	
11	B28-62720-00-00	REAR VIEW MIRROR ASSY,2	1	
12	B22-62231-10-00	L.H. GRIP	1	
13	B22-62240-10-00	R.H. GRIP ASSY.	1	
14	B22-58410-00-00	THROTTLE CABLE ASSY	1	
15	B22-62217-00-00	GRIP TERMINAL ASSY	1	
16	S-3900-05012-04	TAPPING SCREW 5X12	11	
17	S-5800-10035-03	FLANGE BOLT M10X35	1	
18	B22-62210-00-00	HANDLE	1	
19	B22-27800-00-00	RIGHT HANDLE SWITCH ASSY	1	
20	B22-27810-00-00	RIGHT HANDLE SWITCH,1	1	
21	B22-27830-00-00	RIGHT HANDLE SWITCH,2	1	
22	B28-62700-00-00	REAR VIEW MIRROR ASSY	1	
23	S-6701-06065-04	SOCKET BOLT 6X65	2	
24	B22-62226-10-00	GRIP TERMINAL	1	
25	B22-62229-00-00	COLLAR,2	2	
26	B22-62216-10-00	GRIP TERMINAL ASSY,1	1	
27	S-3500-05010-02	PAN HEAD SCREW 5X16	1	
28	B22-62236-00-00	GRIP TERMINAL,2	1	
29	B22-58460-00-00	THROTTLE & PUMP CABLE ASSY	1	
30	B01-58421-00-00	CABLE PUMP	1	
31	B22-58411-00-00	THROTTLE CABLE,1	1	
32	B01-58412-00-00	THROTTLE CABLE,2	1	
33	B01-63576-00-00	SPEED NUT	2	
34	B22-62240-10-00	R.H.GRIP ASSY.	1	

35	B22-62242-00-00	THROTTLE GUIDE TUBE	1	
----	-----------------	---------------------	---	--

F12

SEAT

NO.	PART NO.	DESCRIPTION	REQD. NO.	
			GTR-50	
1	B22-68112-10-00	LUGGAGE 2	1	
2	B22-68111-10-00	LUGGAGE 1	1	
3	B28-66113-00-00	SEAT ASSY,1	1	
4	B28-66114-00-00	SEAT ASSY,2	1	
5	B22-56544-10-00	SEAT CATCH COMP STAY,1	1	
6	B22-56540-10-00	SEAT CATCH COMP	1	
7	B22-56547-00-00	CABLE STAY,2	1	
8	S-5800-06012-04	FLANGE BOLT 6X12	1	
9	S-3900-05012-04	TAPPING SCREW 5X12	8	
10	S-5800-06020-04	FLANGE BOLT 6X20	2	
11	T68-42115-00-00	FRAME BODY NO. PLATE	1	
12	B22-42116-00-00	ANTI-TAMPERING CONTROL PLATE	1	
13	S-5800-06020-02	FLANGE BOLT 6X20	1	
14	S-5800-06020-04	FLANGE BOLT 6X20	1	
15	B22-66221-00-00	PASSENGER BELT	1	
16	S-4101-06195-61	PLATE WASHER	2	
17	B01-63576-00-00	SPRING NUT	2	
18	F03-61144-00-00	DOT TIRE PRESSURE EMBLEM	1	
19	F04-61129-00-00	WARNING STICKER,2	1	

F13

ELECTRICAL,1

GTR50

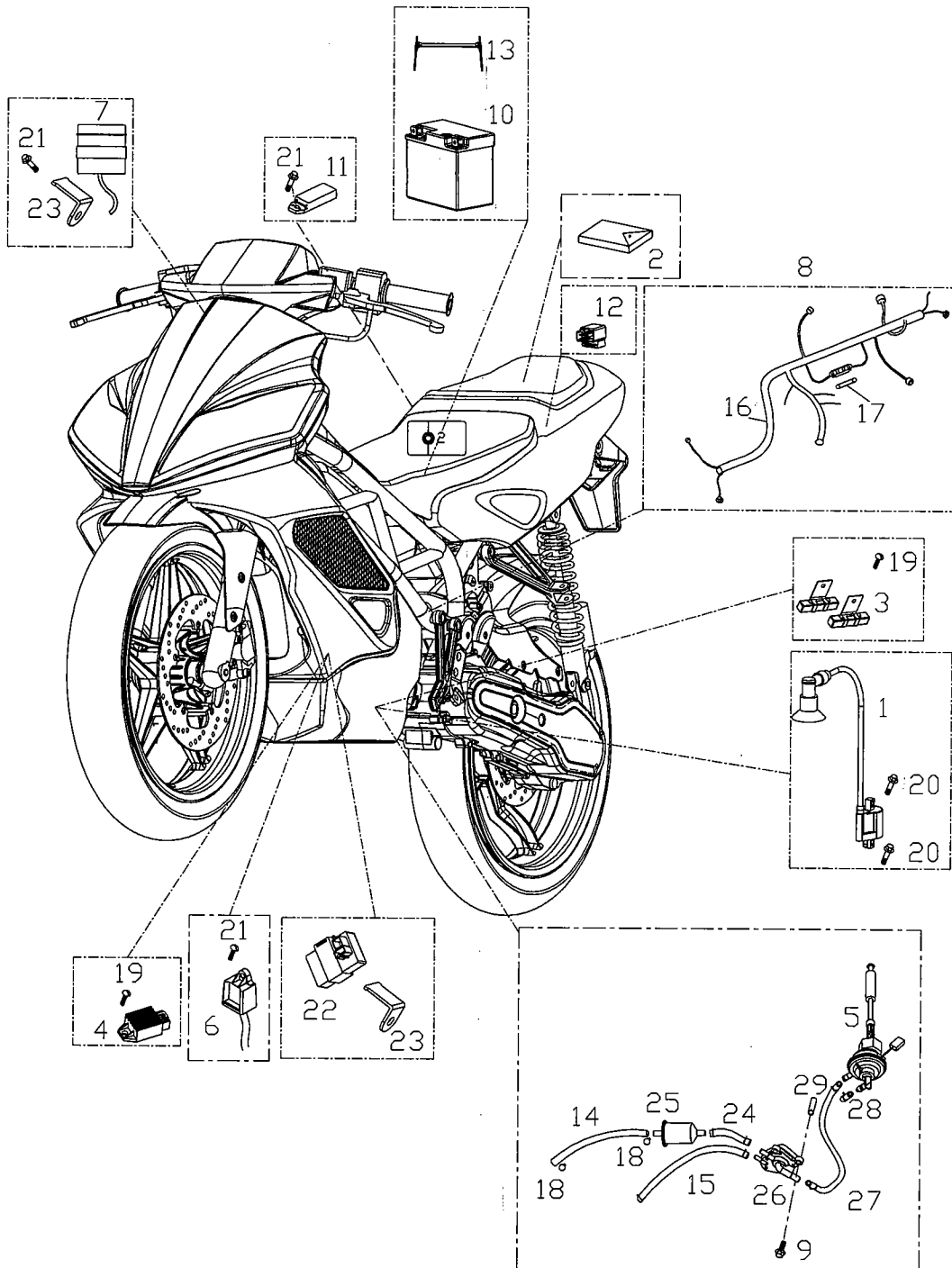

F13

ELECTRICAL,1

NO.	PART NO.	DESCRIPTION	REQD. NO.	
			GTR-50	
1	64A-23140-00-00	ING. COIL	1	
2	B22-71110-00-00	TOOL KIT	1	
3	B22-28410-00-00	RESISTOR COMP	1	
4	64A-21310-00-00	REG. REC. COMP	1	
5	B28-52311-10-00	FUEL COCK BODY	1	
6	64A-23110-00-00	C.D.I ASSY	1	
7	B22-28110-10-00	FLASHER RELAY COMP	1	
8	B22-23610-30-00	WIRE HARNESS ASSY(LED FLASHER)	1	
9	S-5801-06040-01	FLANGE BOLT 6X40	1	
10	F01-23410-00-00	BATTERY ASSY	1	
11	64A-28170-00-00	SENSOR	1	
12	61A-28310-00-00	STARTER RELAY ASSY	1	
13	B22-23436-00-00	RUBBER	1	
14	B23-52371-10-00	FUEL HOSE 1	1	
15	B28-52377-00-00	VACCUM HOSE 1	1	
16	B22-23611-30-00	WIRE HARNESS	1	
17	B01-23657-00-00	FUSE 7A	1	
18	A-4202-08080-00	CLIP 8MM	2	
19	S-3500-05012-03	PAN HEAD SCREW 5X12	2	
20	S-2000-06020-02	HEX. BOLT 6X20	2	
21	S-5800-06016-02	FLANGE BOLT 6X16	3	
22	B22-28110-10-00	FLASHER REALAY COMP	1	
23	B22-28115-00-00	BRACKET	2	
24	B28-52373-00-00	FUEL HOSE 3	1	
25	B23-52410-00-00	FUEL FILTER ASSY	1	
26	A01-52310-00-00	FUEL COCK BODY ASSY	1	
27	B28-52371-00-00	FUEL HOSE 1	1	
28	61G-09489-00-00	RUBBER	1	
29	D06-52014-00-00	COLLAR	1	

F14

SEAT CATCH COMP

GTR50

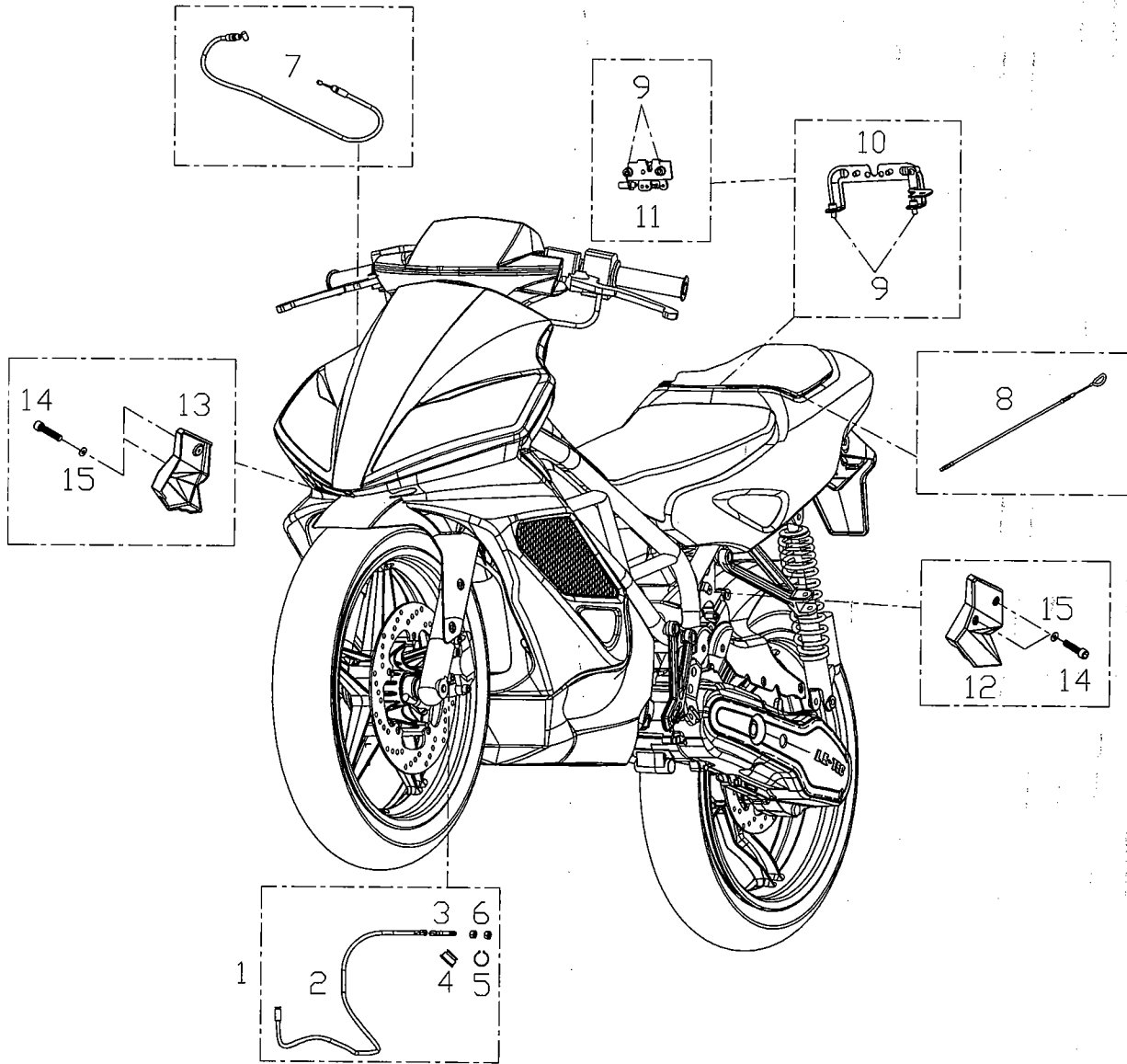

F14

SEAT CATCH COMP

NO.	PART NO.	DESCRIPTION	REQD. NO.	
			GTR-50	
1	B28-24126-00-00	SPEEDOMETER SENSER ASSY	1	
2	B28-24128-10-00	SPEEDOMETER SENSOR,2	1	
3	B28-24129-00-00	SPEEDOMETER SENSOR,1	1	
4	D06-24127-00-00	SPEEDOMETER SENSOR	1	
5	S-4513-01010-00	CIR-CLIP 10MM	1	
6	D06-24148-00-00	NUT	2	
7	B22-56536-10-00	CABLE	1	
8	B22-56546-10-00	CABLE,2	1	
9	S-5800-06012-02	PAN HEAD SCREW 6X12	4	
10	B22-56545-00-00	SEAT CATCH COMP.STAY,2	1	
11	B22-56540-10-00	SEAT CATCH COMP	1	
12	B22-63531-10-67	SIDE COVER,3	1	
13	B22-63541-10-67	SIDE COVER,4	1	
14	S-6700-05012-0G	SOCKET BOLT M5X16	4	
15	S-4101-06113-50	SEALING WASHER	4	

F5

INTAKE

GTR50

13

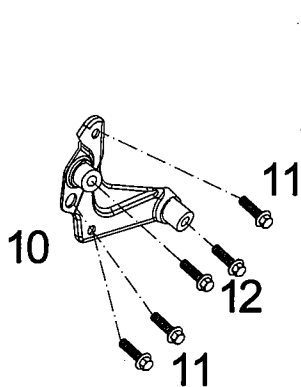
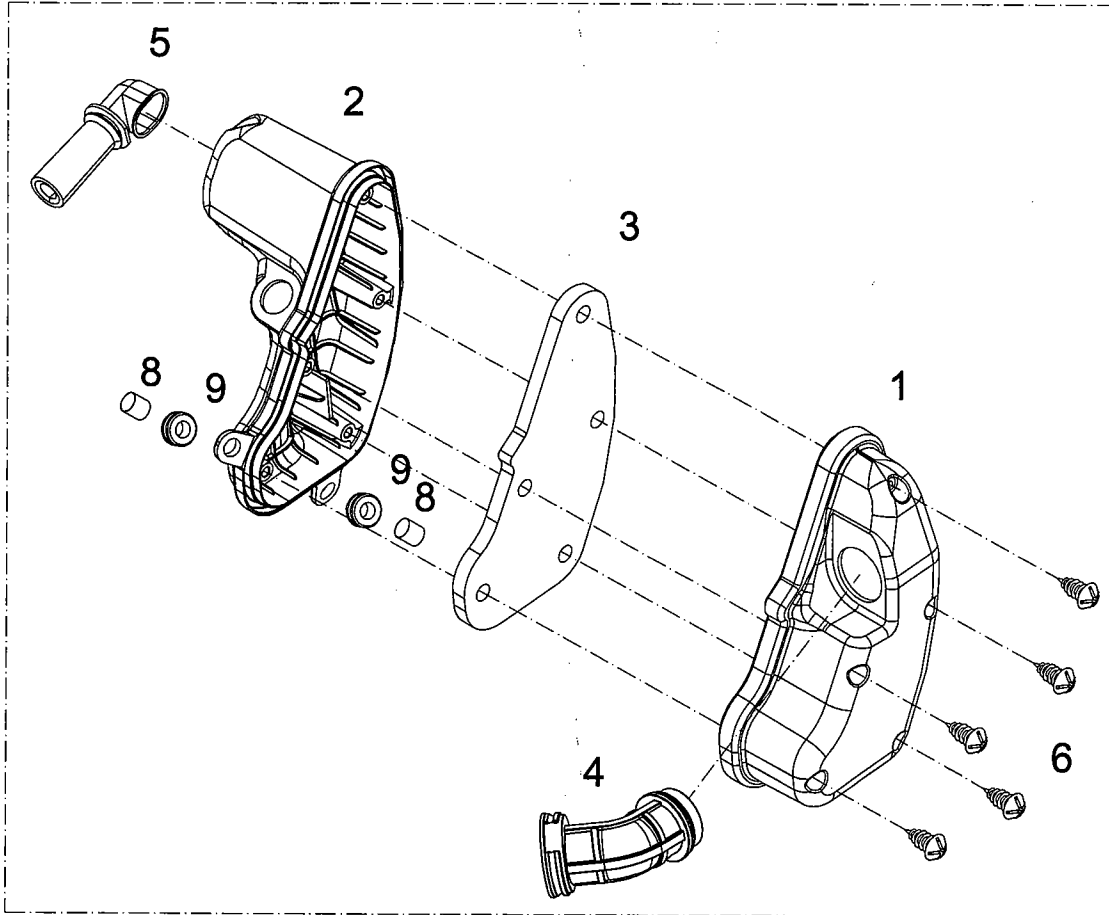

F15**INTAKE**

NO.	PART NO.	DESCRIPTION	REQD. NO.	
			GTR-50	
1	B22-09111-00-00	AIR CLEANER CASE,1	1	
2	B22-09112-00-00	AIR CLEANER CAP,1	1	
3	B22-09126-00-00	BRETHER FILTER	1	
4	B22-09131-10-00	AIR CLEANER JOINT,1	1	
5	F02-09113-00-00	DUCT	1	60&OPEN
6	S-3900-05058-03	TAPPING SCREW 5X58	5	
7	A-4201-23425-00	CLIP 42.5MM	1	
8	B01-09186-00-00	COLLAR	2	
9	B01-09185-00-00	GROMME	2	
10	B22-09187-00-00	MOUNT SHEET ASSY	1	
11	S-3891-06020-04	SCREW W/WASHER 6X20	2	
12	S-3894-05012-04	SCREW W/WASHER 5X12	3	

F16

FORNT MASTER CYLINDER

GTR50

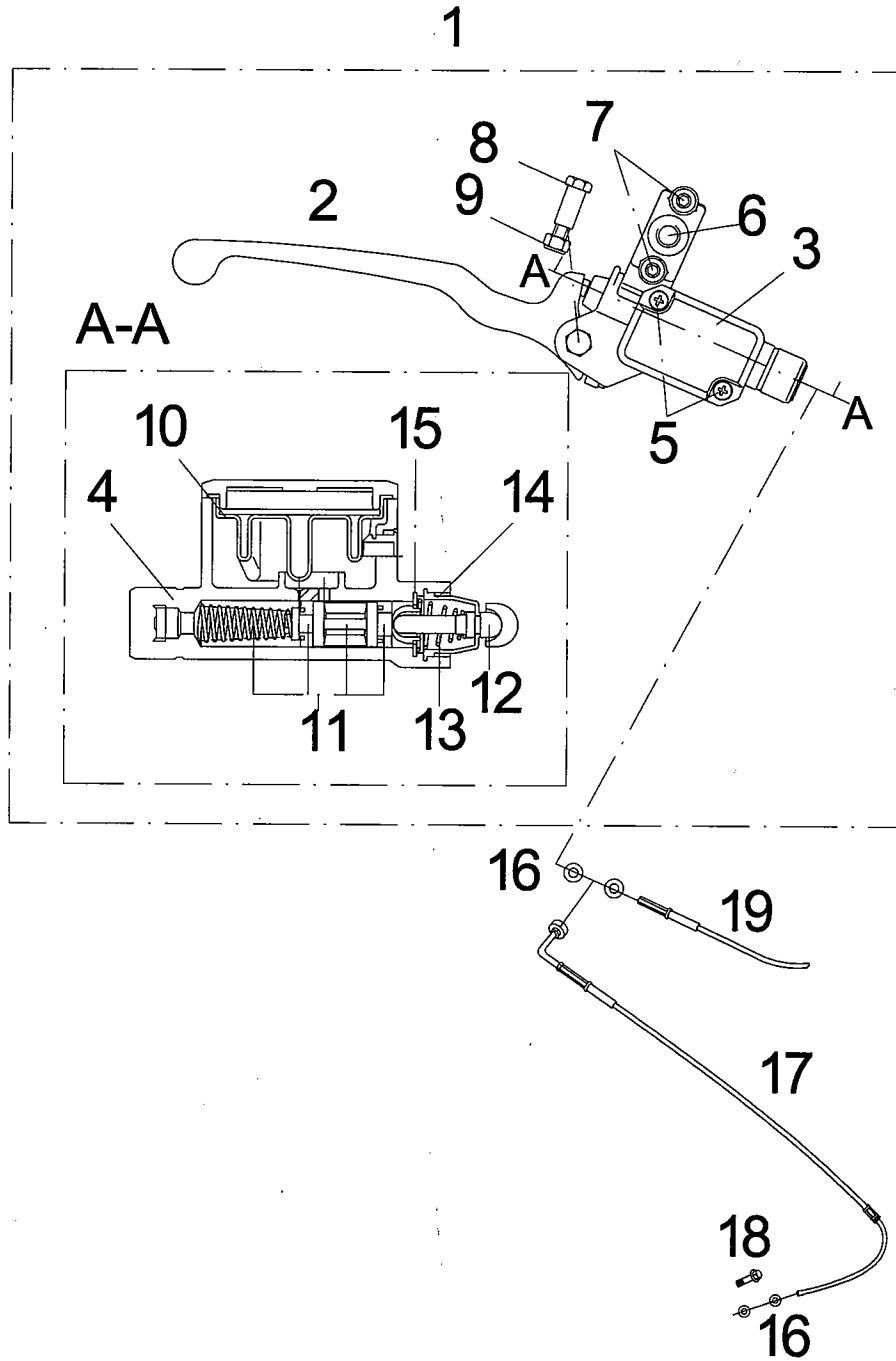

F16

FRONT MASTER CYLINDER

NO.	PART NO.	DESCRIPTION	REQD. NO.	
			GTR-50	
1	B25-45100-00-7F	MASTER CYLINDER ASSY1	1	
2	B25-62263-00-7F	RIGHT LEVER	1	
3	B22-45112-00-00	RESERVOIR CAP	1	
4	B22-45111-00-00	MASTER CYLINDER BODY	1	
5	S-3600-04012-02	FLAT HEAD SCREW 4X12	2	
6	B22-45167-00-00	MASTER CYLINDER BRACKET	1	
7	S-6710-06025-04	SCOKET BOLT 6X25	2	
8	B22-27866-00-00	BOLT 6MM	1	
9	S-4002-06000-04	U NUT 6MM	1	
10	B22-45114-00-00	RESERVOIR DIAPHRAGM	1	
11	B22-45120-00-00	PISTON ASSY,1	1	
12	B22-45145-00-00	PISTON	1	
13	B22-45147-00-00	SPRING	1	
14	B22-45146-00-00	RUBBER	1	
15	B22-45148-00-00	CLIP	1	
16	S-4101-10143-50	PLATE WASHER 10MM	4	
17	B22-45310-00-00	FR. BRAKE HOSE	1	
18	B01-45185-00-00	UNION BOLT	1	
19	B22-27770-10-00	STOP SWITCH ASSY	2	

F17

REAR MASTER CYLINDER

GTR50

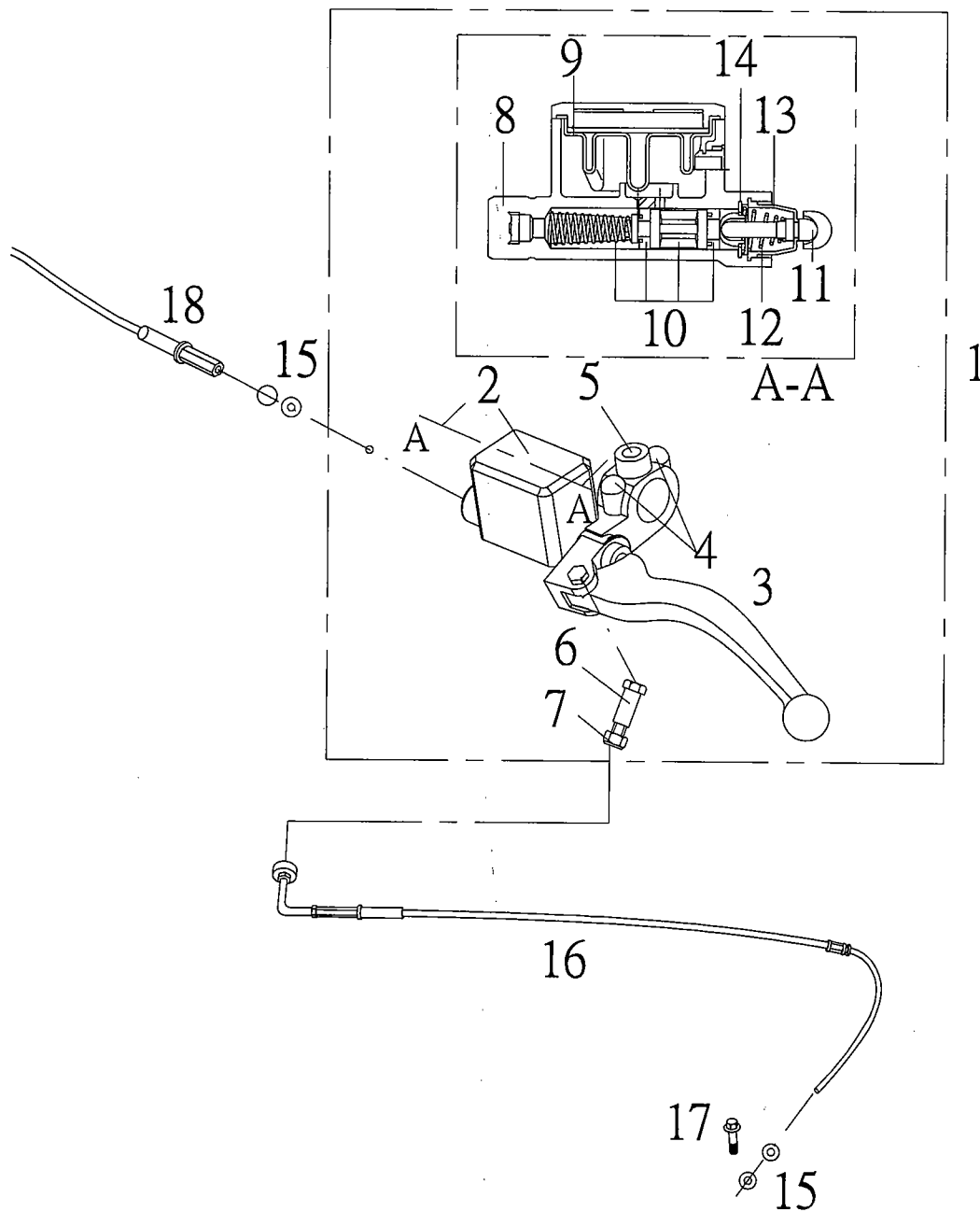

F17

REAR MASTER CYLINDER

NO.	PART NO.	DESCRIPTION	REQD. NO.	
			GTR-50	
1	B25-45150-00-7F	MASTER CYLINDER ASSY,2	1	
2	B22-45112-00-00	RESERVOIR CAP	1	
3	B25-62253-00-7F	RIGHT LEVER	1	
4	S-6710-06025-04	SCOKET BOLT 6X25	2	
5	B22-45167-00-00	MASTER CYLINDER BRACKET	1	
6	B22-27866-00-00	BOLT 6MM	1	
7	S-4002-06000-04	U NUT 6MM	1	
8	B22-45151-00-00	MASTER CYLINDER BODY	1	
9	B22-45114-00-00	RESERVOIR DIAPHRAGM	1	
10	B22-45160-00-00	PISTON ASSY,2	1	
11	B22-45145-00-00	PISTON	1	
12	B22-45147-00-00	SPRING	1	
13	B22-45146-00-00	RUBBER	1	
14	B22-45148-00-00	CLIP	1	
15	S-4101-10143-50	PLATE WASHER 10MM	4	
16	B22-45320-00-00	R.R BRAKE HOSE	1	
17	B01-45185-00-00	UNION BOLT	1	
18	B22-27770-10-00	STOP SWITCH ASSY	1	

F18

OIL TANK

GTR50

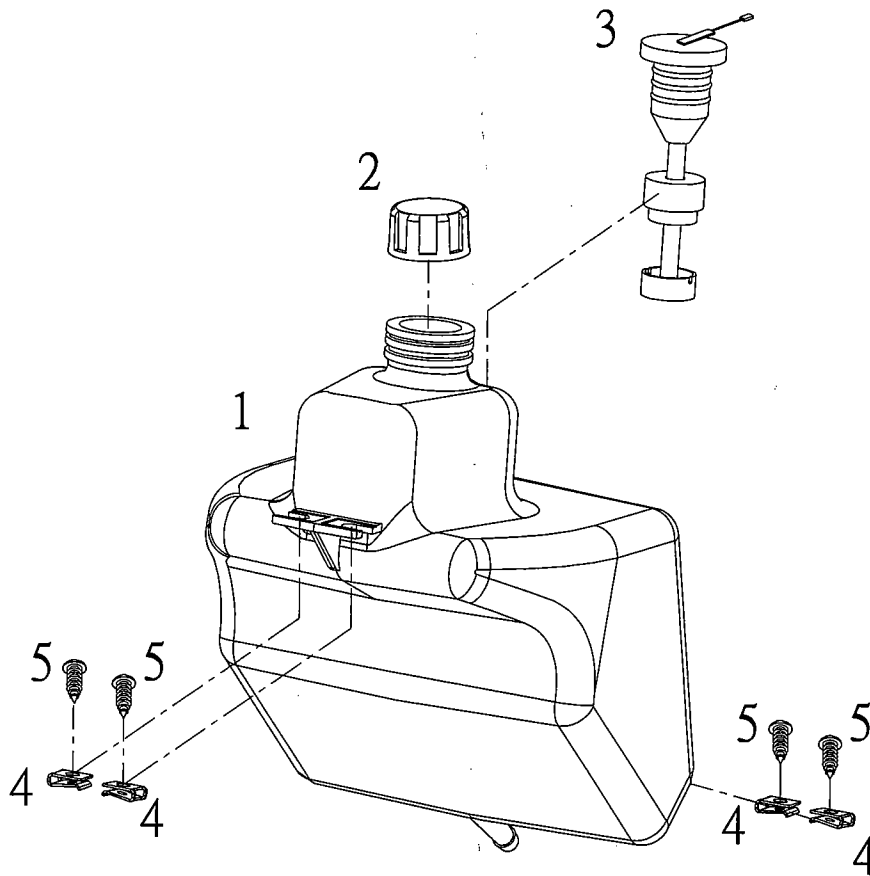

F18**OIL TANK**

NO.	PART NO.	DESCRIPTION	REQD. NO.	
			GTR-50	
1	B22-53110-20-00	OIL TANK	1	
2	D06-53131-00-00	OIL TANK CAP	1	
3	B22-53510-00-00	OIL LEVER GAUGE ASSY.	1	
4	B01-63576-00-00	SPRING NUT 5MM	4	
5	S-3900-05012-04	TAPPING SCREW 5X12	4	

F19

FORNT FORK

GTR50

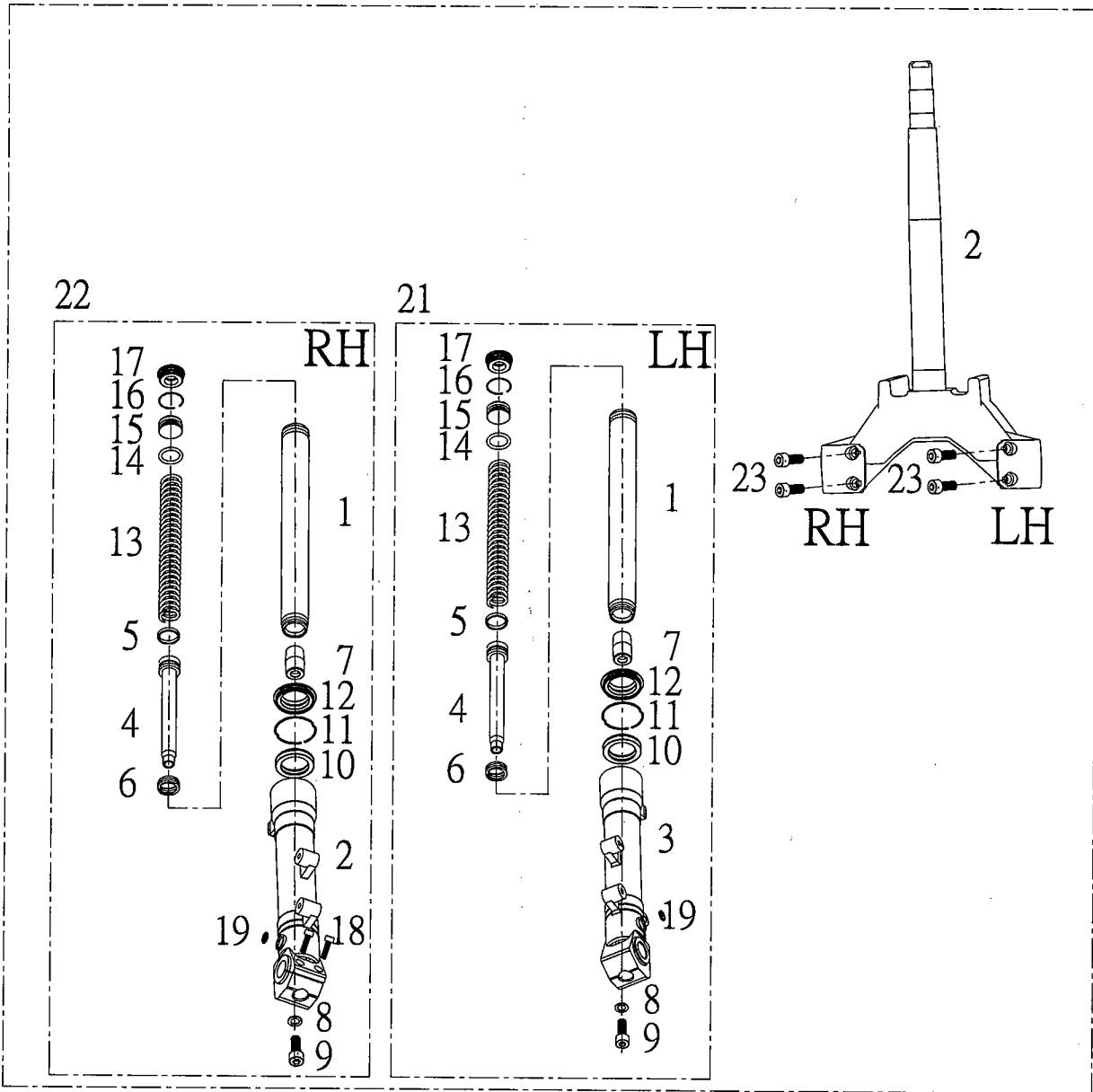

F19

FRONT FORK

NO.	PART NO.	DESCRIPTION	REQD. NO.	
			GTR-50	
1	B22-47110-00-00	INNER TUBE COMP,1	2	
2	B22-47126-00-00	OUTER TUBE,1	1	
3	B22-47136-00-00	OUTER TUBE,2	1	
4	B22-47171-00-00	FR. FORK PISTON	2	
5	B22-47157-00-00	PISTION RING	2	
6	B22-47151-00-00	REBOUND SPRING	2	
7	B22-47154-00-00	INNER TUBE PLUG	2	
8	B22-47187-00-00	PLATE WASHER	2	
9	S-6701-10025-03	SCOKET BOLT 10X25	2	
10	B22-47145-00-00	OIL SEAL	2	
11	B22-47156-00-00	CLIP	2	
12	B22-47125-00-00	DUST SEAL	2	
13	B22-47141-00-00	FRONT FORK SPRING	2	
14	B22-47117-00-00	O-RING	2	
15	B22-47111-00-00	CAP BOLT	2	
16	B22-47112-00-00	CLIP	2	
17	B22-47116-00-00	RUBBER CAP	2	
18	S-6700-06020-03	SCOKET BOLT 6X20	2	
19	B22-47073-00-00	MARK	2	
20	B22-47130-00-00	UNDER BRACKET COMP	1	
21	B22-47102-00-78	L.H. FR. FORK ASSY	1	
22	B22-47103-00-78	R.H. FR. FORK ASSY	1	
23	S-6700-08025-03	SCOKET BOLT 8X25	4	
24	B22-47100-10-78	FR. FORK ASSY	1	

F20

FRONT BRAKE CALIPER

GTR50

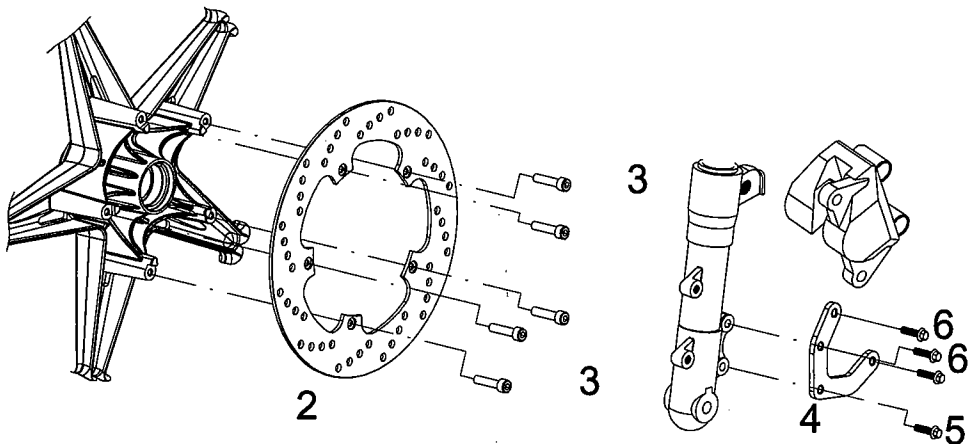
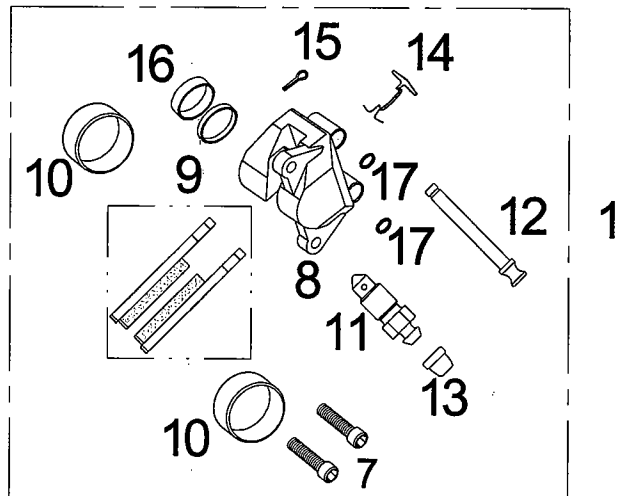

F20

FRONT BRAKE CALIPER

NO.	PART NO.	DESCRIPTION	REQD. NO.	
			GTR-50	
1	B22-45200-20-00	CALIPER ASSY.,1	1	
2	B22-45251-00-00	BRAKE DISC 280mm	1	
3	B25-45276-00-00	ALLEN SCREW	5	
4	B22-45235-10-00	CALIPER STAY	1	
5	S-5801-08035-03	FLANGE BOLT 8X35	2	
6	S-5800-08020-03	FLANGE BOLT 8X20	2	
7	S-6700-08040-03	SCOKET BOLT 8*40	2	
8	B22-45211-00-00	CALIPER BODY	1	
9	B22-45230-00-00	BRAKE PAD KIT	1	
10	B22-45212-00-00	CALIPER PISTON	2	
11	B22-45241-00-00	BREED SCREW	1	
12	B22-45247-10-00	PIN	1	
13	B22-45242-00-00	BREED SCREW CAP	1	
14	B22-45223-00-00	PAD SUPPORT,1	1	
15	S-4251-10010-00	PIN	1	
16	B22-45227-00-00	SEAL KIT	2	
17	B22-45214-00-00	O-RING	2	

F21

REAR BRAKE CALIPER

GTR50

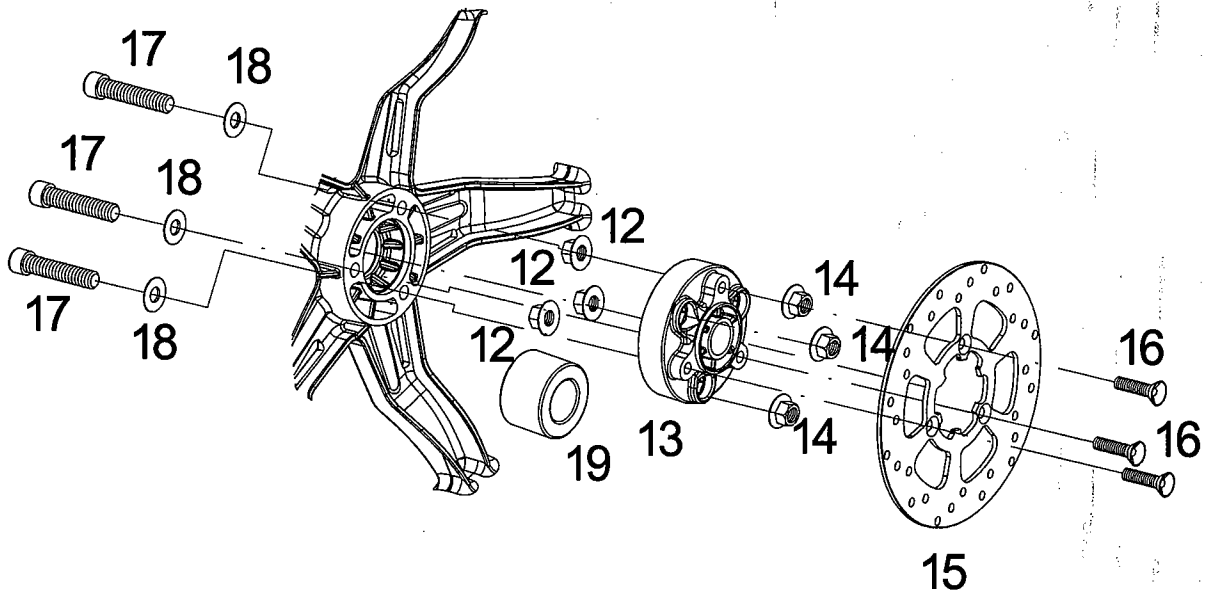
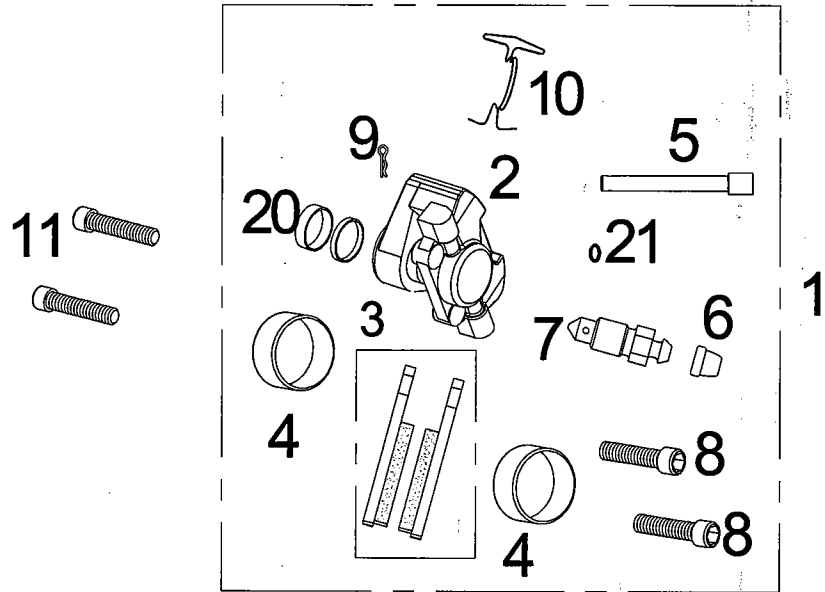

F21

REAR BRAKE CALIPER

NO.	PART NO.	DESCRIPTION	REQD. NO.	
			GTR-50	
1	B22-45250-00-00	CALIPER ASSY.,2	1	
2	B22-45256-00-00	CALIPER BODY	1	
3	B22-45280-00-00	BRAKE PAD KIT	1	
4	B22-45257-00-00	CALIPER PISTON	2	
5	B22-45248-00-00	PIN	1	
6	B22-45242-00-00	BREED SCREW CAP	1	
7	B22-45241-00-00	BREED SCREW	1	
8	S-6700-08035-03	SCOKET BOLT 8*35	2	
9	S-4251-10010-00	SPLIT PIN	1	
10	B22-45224-00-00	PAD SUPPORT,2	1	
11	S-5801-08030-03	FLANGE BOLT 8X30	2	
12	B22-44266-10-00	U NUT	3	
13	B22-44251-10-00	REAR WHEEL HUB COMP.	1	
14	S-4012-10000-03	FLANGE U NUT 10MM	3	
15	B22-45261-10-00	BRAKE DISC 210mm	1	
16	B22-45266-20-00	BOLT	3	
17	S-6701-10050-04	SCOKET BOLT 10*50	3	
18	B22-44246-00-00	CLAMP WASHER	3	
19	B22-44293-20-00	COLLAR,3	1	
20	B22-45267-00-00	SEAL KIT	2	
21	B22-45214-00-00	O-RING	2	

F22

FORNT WHEEL

GTR50

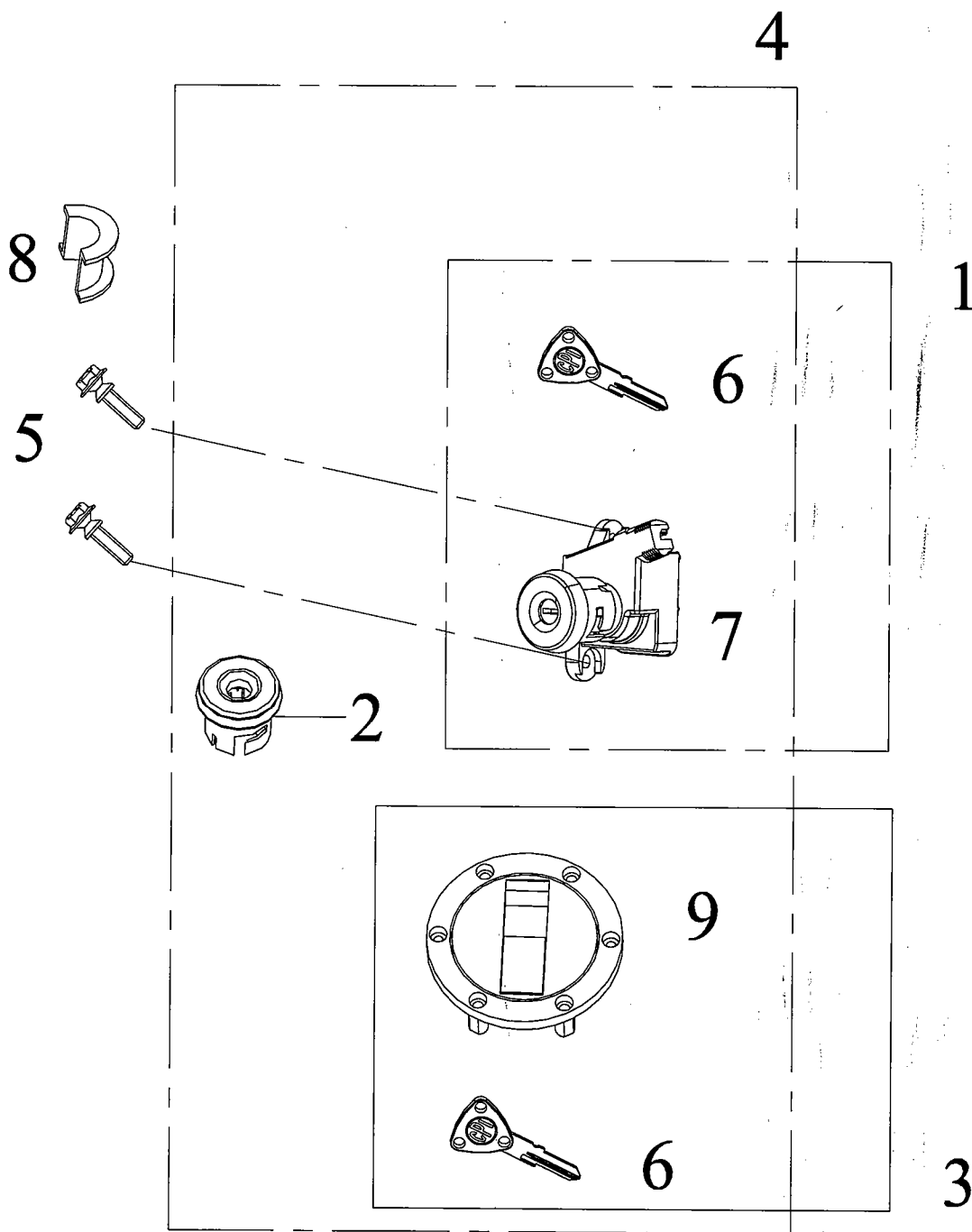

F22**SWITCH ASSY.**

NO.	PART NO.	DESCRIPTION	REQD. NO.	
			GTR-50	
1	B22-56201-20-00	MAIN SWITCH SET	1	
2	B22A56251-00-00	MAIN SWITCH CAP	1	
3	B22-56601-30-00	FUEL TANK LOCK SET	1	
4	B22A56200-00-00	KEY SET	1	
5	S-6700-06014-04	SOCKET BOLT 6*14	2	
6	B22-56271-20-00	KEY	2	
7	B22-56210-00-00	MAIN SWITCH BODY	1	
8	B11-62158-10-00	SLEEVE	1	
9	B22-56610-00-00	FUEL TANK LOCK ASSY.	1	

F23

STICKERS

GTR50

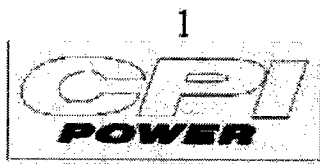
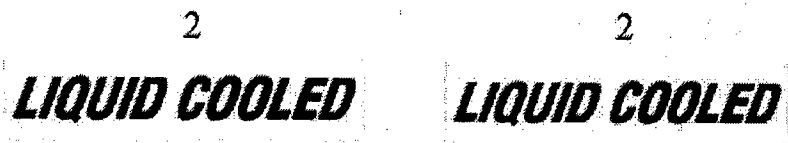
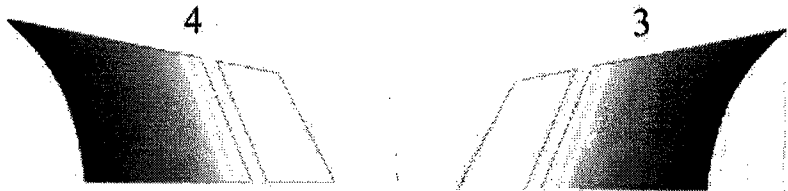
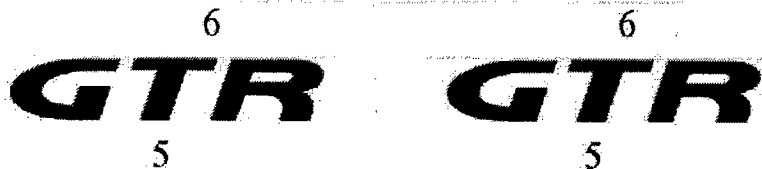

F23		STICKES		
NO.	PART NO.	DESCRIPTION	REQD. NO.	
			GTR-50	
1	B22-61111-00-63	STICKER,1	1	Red, YELLOW
	B22-61111-00-70			BLACK, BULE
2	B22-61121-00-63	STICKER,2	2	Red, YELLOW
	B22-61121-00-70			BLACK, BULE
3	B22-61131-00-78	STICKER,3	1	
4	B22-61141-00-78	STICKER,4	1	
5	B22-61151-00-00	STICKER,5	2	
6	B22-61161-00-63	STICKER,6	2	Red, YELLOW
	B22-61161-00-78			BLACK, BULE
7	B22-61172-00-78	STICKER,7	1	Red, YELLOW
8	B22-61182-00-78	STICKER,8	1	