

aprilia

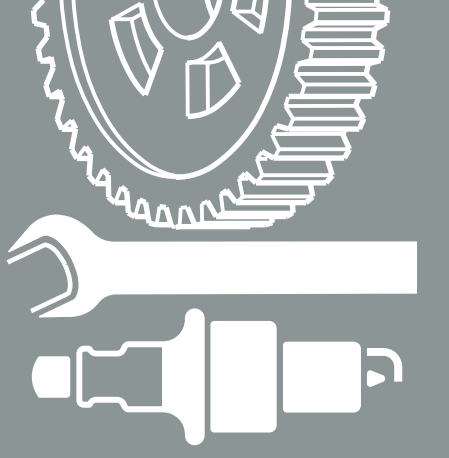

Workshop manual

RS 50

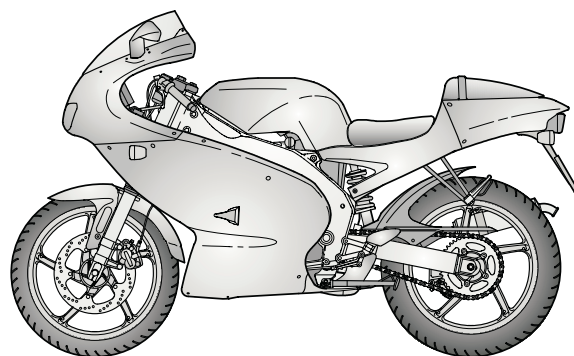

979 X

LIST OF SECTIONS

Introduction

This manual contains information on how to perform the usual vehicle service procedures. This manual does not describe all of the procedures necessary to repair and service the vehicle in detail.

This publication is intended for use by **aprilia** dealers and their trained, experienced mechanics.

The descriptions of many service and repair operations have been intentionally omitted, as it is assumed that the users of this manual have basic mechanical training and basic knowledge of the procedures used for motor vehicle repair, as well as safety rules necessary to ensure their safety and that of the public while repairing motor vehicles. Therefore, it is imperative that you do not attempt to perform any maintenance or repair procedure with which you are not thoroughly familiar, and fully qualified to perform. Such an attempt can result in defective repairs, which can be dangerous both to you, to the owner or user of the vehicle, and to the public in general.

The information and illustrations in this manual are current as of the manual's date of issue. Since **aprilia s.p.a.** continually improves its products, there may be some differences between the vehicle you are servicing and the illustrations and instructions given in this manual. If you have any questions regarding the applicability of any service procedure given in this manual, contact **aprilia** consumer services (A.C.S.). A.C.S. Technical Counselors will be able to assist you with any problems you might face as well as providing you with information on any updates and technical changes to the vehicle you are servicing.

Any change made to technical specifications and vehicle servicing procedures will be documented and distributed to **aprilia** dealers all over the world. These changes will be incorporated in later editions of this manual.

For further information refer to:
SPARE PARTS CATALOGUE # 323 X;
engine workshop manual # 966 X;
service tools manual.

aprilia s.p.a. reserves the right to modify specifications and characteristics of any of its models at any time. **aprilia** makes no representation that this manual covers any such changes.

This manual is protected by copyright in all countries. Electronic storage and the total or partial reproduction and adaptation by any means is prohibited.

The mention of products or services supplied by entities other than **aprilia** is for information purposes only and is not binding in any way.

aprilia s.p.a. is not responsible for the performance or use of any of these products.

First edition: March 2001

Produced and printed by:
CLD s.r.l. Technical manuals division
Via D. Alighieri, 37/A - 56012 Fornacette (PI)
Tel. +39 (0)587 - 42 28 00
Fax +39 (0)587 - 42 28 01
www.cld.it
E-mail: cld@cld.it

on behalf of:
aprilia S.p.A.
Via G. Galilei, 1 - 30033 Noale (VE) - Italia
Tel. +39 (0)41 - 58 29 111
Fax +39 (0)41 - 44 10 54
www.aprilia.com
www.serviceaprilia.com

General information

1

Routine maintenance operations

2

Engine

3

Fuel system

4

Cooling system

5

Electrical system

6

Body work

7

CONTENTS

Chapter 1

- POSITION OF SERIAL NUMBERS 1-2
- SAFETY WARNINGS FOR FUEL, LUBRICANTS COOLANT AND OTHER COMPONENTS 1-3
- LUBRICANTS 1-5
- RUNNING-IN RULES 1-9
- POSITION OF THE WARNING ADHESIVE LABELS 1-10
- SPARE PARTS 1-12
- TECHNICAL DATA 1-12
- LUBRICANT CHART 1-14
- SPECIAL TOOLS 1-15
- GENERAL SPECIFICATIONS FOR TORQUE WRENCH SETTINGS 1-17
- ABBREVIATIONS / SYMBOLS / INITIALS 1-18

Chapter 2

- SERVICING SCHEDULE 2-3
- LUBRICATION POINTS 2-4
- ARRANGEMENT OF THE INSTRUMENTS / CONTROLS 2-5
- INSTRUMENTS AND INDICATORS 2-5
- BATTERY 2-6
- CHECKING AND CLEANING THE TERMINALS 2-7
- REMOVING THE BATTERY 2-7
- CHECKING THE ELECTROLYTE LEVEL 2-8
- RECHARGING THE BATTERY 2-8
- INSTALLING THE BATTERY 2-9
- LONG PERIOD OF BATTERY NON-USE 2-9
- SPARK PLUG 2-9
- AIR CLEANER 2-11
- ADJUSTING THE THROTTLE CONTROL 2-12
- IDLING ADJUSTMENT 2-12
- CARBURETOR CONTROLS 2-13
- COLD START LEVER 2-13
- CHECKING THE GEARBOX OIL 2-13
- CHECKING TOPPING UP 2-14
- CHANGING THE GEARBOX OIL 2-15
- 2 STROKE OIL TANK 2-17
- COOLANT 2-18
- CHECKING AND TOPPING UP THE BRAKE FLUID 2-22
- FRONT BRAKE 2-23
- REAR BRAKE 2-25
- CHANGING THE FRONT BRAKE FLUID 2-26
- CHANGING THE REAR BRAKE FLUID 2-27
- BLEEDING THE BRAKE CIRCUITS 2-28
- ADJUSTING THE REAR BRAKE 2-30
- ADJUSTING THE CLUTCH 2-31
- ADJUSTING THE SHIFT LEVER 2-31
- STEERING 2-32
- DRIVE CHAIN 2-33
- ROUTINE MAINTENANCE AND SERVICING OPERATIONS 2-36
- FUEL LINES 2-38
- BRAKE PIPES/HOSES 2-38
- COOLING 2-38
- SYSTEM HOSES 2-38
- 2 STROKE OIL PIPES/HOSES 2-39
- TIGHTENING NUTS AND BOLTS 2-39

FASTENERS	2-40
Chapter 3	
ENGINE COMPONENTS THAT CAN BE REMOVED WITHOUT REMOVING THE ENGINE FROM THE FRAME	3-2
REMOVING THE COMPLETE ENGINE FROM THE FRAME	3-3
Chapter 4	
FUEL TANK	4-2
MAINTENANCE	4-3
CHECKING THE FUEL FEED	4-3
REMOVING THE FUEL VALVE	4-4
REMOVING THE CARBURETOR	4-4
REMOVING THE 2 STROKE OIL TANK	4-6
Chapter 5	
REMOVING THE RADIATOR	5-2
REMOVING THE FILLER CAP	5-3
Chapter 6	
INTRODUCTION	6-2
RECOMMENDED EQUIPMENT	6-2
MAIN WIRING DIAGRAM	6-3
LOCATION OF COMPONENTS	6-4
IGNITION CIRCUIT	6-5
RECHARGE AND GENERAL POWER SUPPLY CIRCUIT	6-7
STARTER CIRCUIT	6-9
SENSOR CIRCUIT	6-12
DIRECTION INDICATORS CIRCUIT	6-13
HORN CIRCUIT	6-15
BRAKING LIGHTS CIRCUIT	6-17
LIGHT CIRCUIT	6-19
LIGHT CIRCUIT <small>ASD</small>	6-20
ELECTRICAL CONNECTORS	6-23
BULBS	6-24
CHANGING THE HEADLIGHT BULBS	6-24
CHANGING PARKING LIGHT BULB	6-24
CHANGING HIGH BEAM BULB	6-25
CHANGING LOW BEAM BULB	6-25
CHANGING THE FRONT AND REAR TURN SIGNAL BULBS	6-26
CHANGING THE REAR LIGHT BULB	6-26
ADJUSTING THE HEADLIGHT BEAM VERTICALLY	6-27
ADJUSTING THE HEADLIGHT BEAM HORIZONTALLY	6-27
CHANGE FUSES	6-29
CHECKING THE SWITCHES	6-31
Chapter 7	
APPLYING THE TRANSFERS	7-2
REMOVING THE RIDER SADDLE	7-4
REMOVING THE SADDLE LOCK	7-4
REMOVING THE PASSENGER SADDLE	7-4
REMOVING THE SIDE FAIRINGS	7-5
REMOVING THE FUEL TANK	7-6
EMPTYING THE FUEL TANK	7-7
REMOVING THE AIR BOX	7-8

REMOVING THE LEFT HANDLEBAR HANDGRIP 7-9

REMOVING THE LEFT HANDLEBAR ELECTRICAL CONTROLS 7-9

REMOVING THE CLUTCH CONTROL 7-10

REMOVING THE THROTTLE CONTROL 7-11

REMOVING THE RIGHT HANDLEBAR ELECTRICAL CONTROLS 7-12

REMOVING THE STOP SWITCH 7-12

REMOVING THE FRONT BRAKE CONTROL 7-13

REMOVING THE RIGHT HANDLEBAR 7-14

REMOVING THE LEFT HANDLEBAR 7-14

REMOVING THE IGNITION SWITCH/STEERING LOCK 7-15

REMOVING THE REAR VIEW MIRRORS 7-15

REMOVING THE FRONT FAIRING 7-16

REMOVING THE WINDSHIELD 7-16

REMOVING THE HEADLIGHT 7-17

REMOVING THE DASHBOARD 7-17

REMOVING THE INSTRUMENT PANEL FRAME 7-18

REMOVING THE FRONT MUDGUARD 7-19

REMOVING THE FRONT DIRECTION INDICATORS 7-19

REMOVING THE LOWER FAIRING 7-20

REMOVING THE REAR FAIRING 7-21

REMOVING THE REAR LIGHT 7-22

REMOVING THE LICENSE PLATE HOLDER 7-22

REMOVING THE PILLAR COVER 7-23

REMOVING THE REAR TURN SIGNALS 7-23

REMOVING THE REAR MUDGUARD 7-24

REMOVING THE REAR FOOTREST SUPPORTS 7-24

REMOVING THE REAR FOOTRESTS 7-25

REMOVING THE FRONT FOOTREST SUPPORT (LEFT SIDE) 7-25

REMOVING THE FRONT FOOTREST SUPPORT (RIGHT SIDE) 7-26

REMOVING THE FRONT FOOTREST 7-27

REMOVING THE SHIFT LEVER 7-27

REMOVING THE BRAKE PEDAL 7-28

REMOVING THE EXHAUST PIPE 7-28

REMOVING THE MUFFLER 7-30

CLEANING THE EXHAUST PIPE AND MUFFLER 7-31

REMOVING THE SIDE STAND 7-32

REMOVING THE CHAIN GUIDE 7-33

REMOVING THE PILLAR 7-33

FRONT WHEEL 7-36

REMOVING THE COMPLETE FRONT WHEEL 7-37

DISASSEMBLING THE FRONT WHEEL 7-38

REASSEMBLY FRONT WHEEL 7-40

FRONT BRAKE 7-42

CHANGING THE FRONT BRAKE PADS 7-43

REMOVING THE FRONT BRAKE MASTER CYLINDER 7-44

REMOVING THE BRAKE DISC 7-44

FRONT FORK 7-45

REMOVING THE FRONT FORK 7-46

DISASSEMBLING THE FORK 7-47

CHECKING THE COMPONENTS 7-50

REFITTING THE FORK 7-51

STEERING 7-54

REMOVING THE STEERING 7-55

CHECKING THE COMPONENTS 7-56

REFITTING THE STEERING 7-57

REAR WHEEL	7-58
REMOVING THE COMPLETE REAR WHEEL	7-59
REASSEMBLY REAR WHEEL	7-61
REAR BRAKE	7-63
CHANGING THE REAR BRAKE PADS	7-64
REMOVING THE REAR BRAKE DISC	7-65
REMOVING THE REAR BRAKE MASTER CYLINDER	7-65
REMOVING THE REAR SUSPENSION	7-66
CHECKING THE SUSPENSION COMPONENTS	7-67
REMOVING THE DRIVE CHAIN	7-68
REMOVING THE SWING ARM	7-69
DISASSEMBLING THE SWING ARM	7-71
REASSEMBLING THE SWING ARM	7-72

SAFETY WARNINGS

Throughout this manual, you will see the following symbols:

WARNING

When you find this symbol on the vehicle or in the manual, this indicates that a potential for serious personal injury or death exists.

Failure to follow this warning may result in serious risk of personal injury or death, of the mechanic working on the vehicle, the operator of the vehicle, or the general public.

It also indicates that serious and permanent damage to the vehicle is possible.

CAUTION

This statement indicates a potential hazard which may result in some personal injury, or damage to the vehicle.

NOTE The word "NOTE" in this manual precedes important information or instructions to which special attention must be given.

GENERAL SAFETY RULES

CARBON MONOXIDE

If it is necessary to run the engine in order to carry out maintenance operation, make sure that the area in which you are operating is properly ventilated.

Never run the engine in enclosed spaces.

If it is necessary to work indoors, use an exhaust evacuation system.

WARNING

The exhaust fumes contain carbon monoxide, a poisonous gas that can cause loss of consciousness and even death.

GASOLINE

Work in a well ventilated area. Keep cigarettes, flames or sparks away from the work area and from the place where gasoline is stored.

WARNING

Gasoline is extremely flammable and becomes explosive under certain conditions.

KEEP GASOLINE AWAY FROM CHILDREN.

HOT COMPONENTS

WARNING

The engine and the components of the exhaust system become very hot and remain hot for some time after the engine has been stopped.

Before handling these components, wear insulating gloves or wait until the engine and the exhaust system have cooled down.

USED ENGINE OIL AND FORK OIL

▲ WARNING

Use latex gloves for the maintenance operations that require contact with used oil.

Used oil may cause skin cancer if repeatedly left in contact with the skin for prolonged periods.

Although this is unlikely unless you handle used oil on a daily basis, it is advisable to thoroughly wash your hands with soap and water after handling used oil.

KEEP OIL AWAY FROM CHILDREN.

BRAKE FLUID

▲ CAUTION

The brake fluid can damage painted, plastic or rubber parts. When performing maintenance operations on the braking system, place a clean shop towel on these parts.

Always wear goggles when servicing the brake system with brake fluid.

Brake fluid is extremely destructive to your eyes.

If you should accidentally get brake fluid in your eyes, flush immediately with a large quantity of cool clear water and seek professional medical assistance immediately.

KEEP BRAKE FLUID AWAY FROM CHILDREN.

CLUTCH CONTROL FLUID

▲ CAUTION

The clutch control fluid can damage painted, plastic or rubber parts.

When performing maintenance operations on the clutch control system, place a clean shop towel on these parts.

Always wear goggles when servicing the clutch control system with clutch control fluid.

Clutch control fluid is extremely destructive to your eyes.

If you should accidentally get clutch control fluid in your eyes, flush immediately with a large quantity of cool clear water and seek professional medical assistance immediately.

KEEP CLUTCH CONTROL FLUID AWAY FROM CHILDREN.

COOLANT

In certain conditions, the ethylene glycol contained in the engine coolant is flammable: its flame is invisible, but you can be burned anyway.

▲ WARNING

Avoid spilling the engine coolant on the exhaust system or on the engine components. They may be hot enough to cause the coolant to ignite and burn without a visible flame. The coolant (ethylene glycol) can cause skin irritation and is poisonous if swallowed.

Engine coolant is sweet tasting, and therefore extremely attractive to pets and other animals, as well as being extremely toxic.

Do not leave coolant in an open container where animals may be able to drink it.

KEEP COOLANT AWAY FROM CHILDREN.

Do not remove the radiator cap when the engine is hot. The coolant is under pressure and may cause burns.

BATTERY HYDROGEN GAS AND ELECTROLYTE

▲ WARNING

The battery gives off explosive gases; keep cigarettes, flames and sparks away from the battery. Provide adequate ventilation when operating or recharging the battery.

The battery contains sulphuric acid (electrolyte). Contact with the skin or the eyes may cause serious burns.

Always wear tight fitting goggles and protective clothing when handling battery electrolyte. It is particularly important for you to protect your eyes, since even a minuscule amount of battery acid can destroy your vision.

Should you accidentally get even the smallest amount of battery acid on your skin or eyes, immediately flush with large quantities of clear cool water and immediately seek professional medical attention.

The electrolyte is poisonous.

If the electrolyte is accidentally swallowed, drink large quantities of water or milk and then milk of magnesia or vegetable oil.

Seek professional medical attention immediately.

KEEP BATTERIES AND ELECTROLYTE AWAY FROM CHILDREN.

PRECAUTIONS AND GENERAL INFORMATION

Follow with care these recommendations when repairing, disassembling and reassembling the vehicle.

▲ WARNING

The use of open flames is forbidden for any type of operation.

Before commencing any service or inspection operation on the vehicle, switch off the engine and remove the key, wait until the engine and the exhaust system have cooled down and, if possible, raise the vehicle with the suitable equipment onto firm flat ground.

In order to avoid burns, be careful not to touch any parts of the engine or exhaust systems which have not cooled down completely.

The brakes also get quite hot in operation.

Be sure that the brakes have cooled thoroughly before beginning any service operations.

Avoid the temptation to hold any hardware or other part of the vehicle in your mouth while working on the vehicle.

No part of the motorscooter is edible and some of the coatings, plastics, and platings, etc. are noxious if not outright toxic.

If not expressly described, the reassembly of the units is carried out by reversing the order of operations. Handle fuel with the greatest caution.

See gasoline warning. Never use fuel as a solvent for cleaning the vehicle.

Disconnect the negative cable (-) from the battery when electric welding.

When two or more persons are working together, make sure that each is working in safe conditions.

Be sure that all the mechanics working on any one vehicle are thoroughly briefed as what each will be doing, and insure that one mechanic is responsible for insuring that all safety related items, such as tightening torques, are properly considered.

BEFORE DISASSEMBLY

Remove all dirt, mud, dust and foreign bodies from the motorcycle before removing any components. When specified, use the service tools specially designed for this motorcycle.

DISASSEMBLY OF COMPONENTS

Never loosen and/or tighten nuts and bolts with pliers or other similar tools: always use a proper wrench.

Mark the positions of all unions and connections (hoses, wires, etc.) before disconnecting them with clearly distinguishable marks.

Each component must be clearly marked so that it can be identified for refitting.

Clean and wash each removed component with fire-proof solvent.

Paired components must be kept together, as they become "matched" after normal wear. Some paired components must either be used together or both replaced.

Keep away from heat sources.

REFITTING COMPONENTS

⚠ WARNING

Never use a circlip twice. When a circlip is removed, it must be replaced with a new one. When assembling a new circlip, be careful not to stretch its ends more than strictly necessary to place it on the shaft. After installing a circlip, make sure that it is completely and firmly inserted in its seat.

Do not use compressed air to clean bearings.

NOTE Bearings must turn freely with no sticking and/or noise. Replace bearings that show any roughness when the inner race is turned.

Use only original **aprilia** Spare Parts for replacement.

Use only the recommended lubricants and sealing agents.

Lubricate all metal parts before refitting them. Pay particular attention to lubricate internal engine parts such as piston rings, valves, etc. Use proprietary assembly lubricants when appropriate.

When tightening nuts and bolts, start with the larger diameter or inner ones and proceed in diagonal order. Tighten them in gradual steps before applying the final tightening torque.

Always replace all gaskets, circlips, snap rings and O-rings. Replace self-locking nuts if the finger torque allows the nut to be run on to its matching bolt more than one half turn. Replace the pins, screws and bolts if they are nicked, cracked, or if there is any sign of thread damage.

Thoroughly clean all mating surfaces before reassembly.

Apply a thin film of lithium-based grease to oil seal rims.

Always replace oil seals. Upon reassembly, apply a thin film of lithium-based grease to the sealing lip of all oil seals before it is assembled over its matching shaft.

Check to make sure that each component has been fitted properly.

After carrying out repairs or routine servicing, go through the pre-ride checklist thoroughly before riding the motorcycle or allowing it to be ridden. Take a trial run in a parking lot or other low traffic area before returning the motorcycle to its owner.

USING THE MANUAL

HOW TO USE THE MANUAL:

This manual is divided up into chapters. Each chapter is based on a category of main components. Refer to the MAIN CONTENTS list.

Unless expressly stated otherwise, follow the disassembly steps in reverse order when reassembling units. The terms "right" and "left" are intended as the rider's right and left when sitting in the normal riding position. Consult the "USE AND MAINTENANCE" handbook for information on the normal use and servicing of the motorcycle.

In this manual, variants from the standard version are marked with the following symbols:

ASD Automatic Switch-on Device version

OPT optional

NOTES

General information

1

POSITION OF SERIAL NUMBERS

These numbers are required for vehicle registration.

NOTE The alteration of the identification numbers is an offence, punishable with criminal and administrative sanctions. In particular, the alteration of the frame number will result in the immediate invalidation of the warranty.

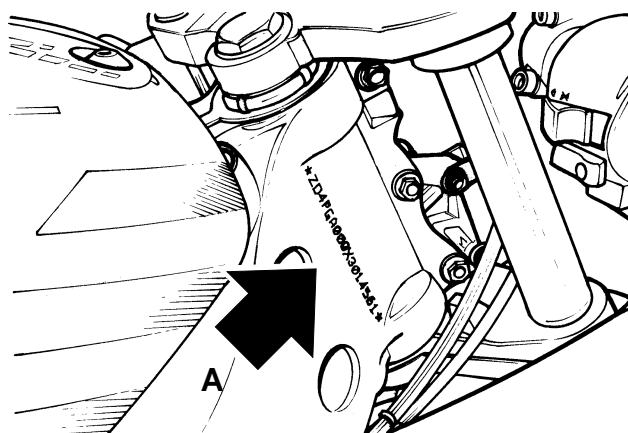

VEHICLE IDENTIFICATION NUMBER (V.I.N.) (FRAME NUMBER)

Every motorcycle produced by aprilia receives a vehicle identification number (V. I. N.) stamped on the steering head of the frame (A), as shown above, and also on the identification plate (B) which is located on the front portion of the main frame.

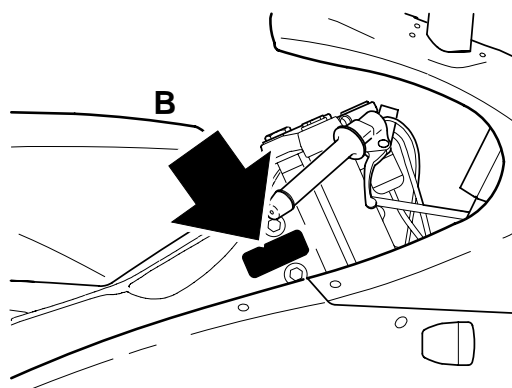

INFORMATION CONTAINED IN THE MOTORCYCLE IDENTIFICATION NUMBER

DIGIT MEANING

- 1) Manufacturer's identification alphanumeric code.
- 2) Motorcycle type.
- 3) Model.
- 4) Country for which the motorcycle is intended.
- 5) Production year.
- 6) Assembling factory designation
(N = NOALE- VE- ,
S = SCORZÉ -VE- ,
0 = NOT SPECIFIED).
- 7) Sequential serial number.

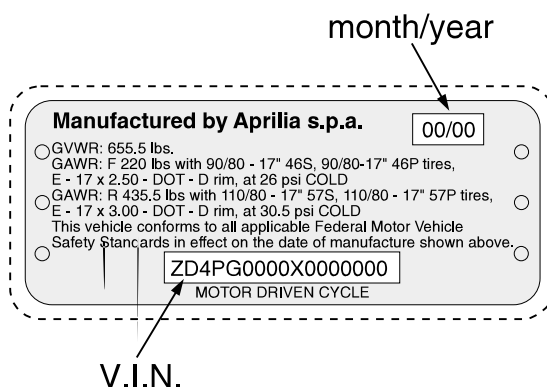
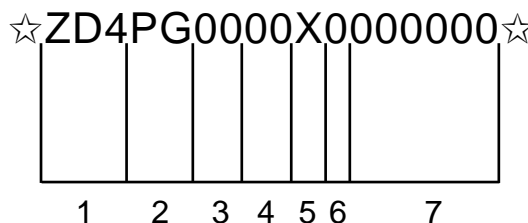

ENGINE NUMBER

The engine number is stamped on the rear of the engine, next to the sprocket.

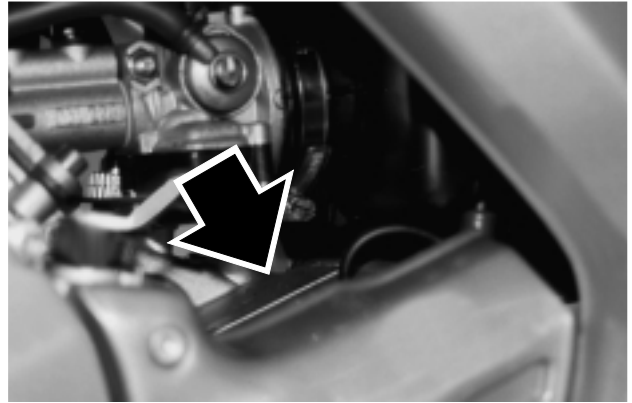

1

SAFETY WARNINGS FOR FUEL, LUBRICANTS COOLANT AND OTHER COMPONENTS

FUEL

▲ WARNING

Gasoline is extremely flammable and in some conditions can become explosive. Therefore, it is necessary to refuel and carry out maintenance operations involving the fuel system in a well-ventilated area with the engine off.

Do not refuel or do any maintenance on the fuel system with the engine running.

Do not smoke while refueling or near fuel vapors. Never allow any portion of the fuel system to come in contact with open flames, sparks or other heat sources.

Be careful to avoid spilling fuel when you are refueling. Spilled fuel could ignite when it contacts hot engine or exhaust system surfaces.

If you accidentally spill some fuel, make sure that it is wiped up or completely evaporated before starting the vehicle.

Since gasoline expands in the fuel tank when the vehicle is sitting in the open sun, never fill the tank completely to the brim.

Leave at least one inch of expansion space.

Avoid any contact of the fuel with your skin, and avoid inhalation of fuel vapors.

Do not ever attempt to siphon fuel from one container to another using your mouth as suction for a siphon hose.

Gasoline is poisonous and carcinogenic and contains chemical substances that cause birth defects and other reproductive problems.

If gasoline should be accidentally spilt on the skin or clothes, immediately wash it off with soap and water and change clothes.

Should you accidentally spill gasoline in your eyes, flush with a large quantity of water and immediately contact a health professional.

Should you accidentally get gasoline into your mouth, do not induce vomiting.

Drink a large quantity of milk or clear water and immediately contact a health professional.

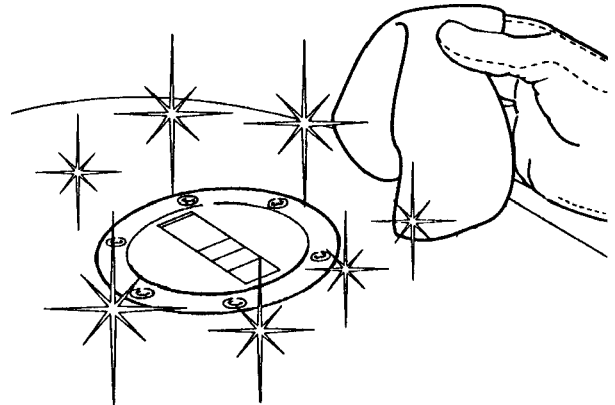

Never try to siphon gasoline by sucking it with your mouth.

Use a manual pump or a similar system.

If your vehicle overturns, it will leak gasoline which is extremely flammable.

Flames or sparks may ignite this which will not only destroy the vehicle but also could do serious property damage to surrounding property and cause serious injuries or even death.

ALWAYS KEEP GASOLINE AWAY FROM CHILDREN.

DISPOSE OF UNWANTED GASOLINE PROPERLY, DO NOT DUMP IT INTO STORM SEWERS OR INTO A SINK OR TOILET.

▲ CAUTION

Before opening the fuel filler cap, if necessary, clean the cap and the part around it with a clean cloth. Prevent any foreign material from getting into the fuel tank, this could lead to serious engine damage.

If you use any container or funnel for refueling, make sure that it is perfectly clean. Any foreign matter getting into the fuel tank may lead to severe damage.

▲ WARNING

Do not add any additives or other substances to the gasoline.

Do not refuel the tank completely; the fuel should never be touching the rim of filler cap seat hole.

After refueling, replace the fuel filler cap (1) in the correct position and make sure that it is properly closed.

Use only unleaded gasoline minimum octane rating (M+R)/2 method 90.

FUEL TANK CAPACITY
(reserve included): 13 / (3.4 gal).

TANK RESERVE: 2.6 / (0.69 gal).

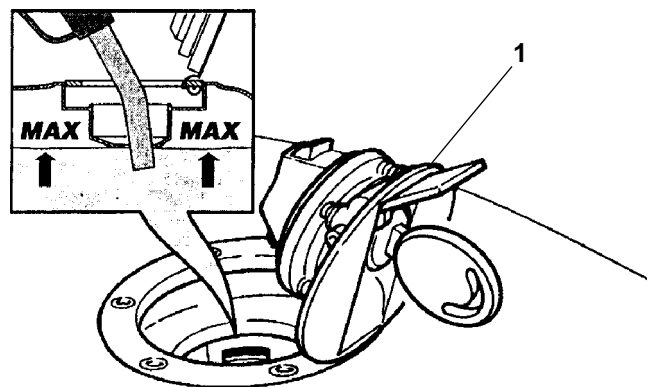

LUBRICANTS

▲ WARNING

Proper vehicle lubrication is critical to safe operation. Failure to maintain proper lubricant levels or to use the proper type of clean, new lubricant, can lead to an engine or transmission seizure with subsequent accident, serious injury or death.

Use latex gloves for the maintenance operations that require contact with used oil.

Used oil may cause skin cancer if repeatedly left in contact with the skin for prolonged periods. Although this is unlikely unless you handle used oil on a daily basis, it is advisable to thoroughly wash your hands with soap and water after handling used oil.

**KEEP OIL AWAY FROM CHILDREN.
DISPOSE OF OIL PROPERLY.**

▲ CAUTION

Be very careful when putting oil in your vehicle not to spill oil.

Clean up any oil spilled immediately because oil can damage the finish of your vehicle.

Also, oil on the tires creates an extremely slippery and therefore dangerous situation.

In case of lubricant leakage do not ride the vehicle, but check to determine the cause of the leakage and repair it.

ENGINE OIL

▲ WARNING

If the engine oil pressure warning light LED “” (1) remains on (when the engine is running), or if it comes on during the normal running of the engine, this means that the oil system is not developing sufficient pressure.

Failure to heed this warning can lead to engine seizure, upset, and serious injury or even death.

▲ CAUTION

Perform these maintenance operations at one-half of the specified intervals, if the vehicle is often used in rainy or very dusty conditions, or on unpaved roads.

As an alternative to the recommended oil, it is possible to use high-quality oils with characteristics in compliance with or superior to the ISO-L-ETC ++, A.P.I. TC ++ specifications.

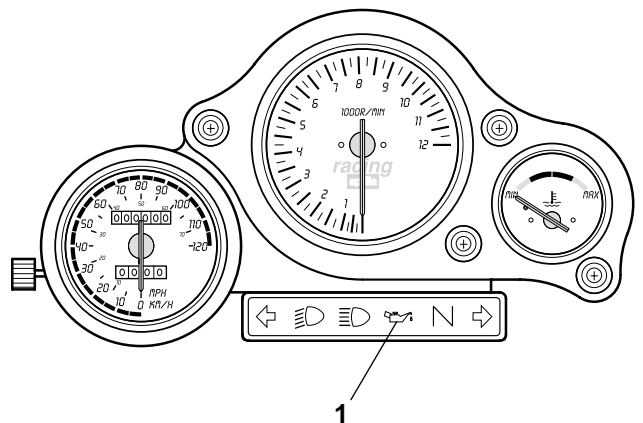

FORK OIL





▲ WARNING

By changing the damper settings and/or the viscosity of the oil contained in them, the suspension response may be altered partially.

Standard oil viscosity: SAE 20 W.

The viscosity ratings which can be chosen based on the type of fork stiffness desired (SAE 5W soft, 20W stiff).

The two products can be used in different percentages until the desired response is obtained.

One of the properties of F.A. and  F. A. 5W or  F. A. 20W fork oil (as an alternative  Agip FORK 5W or  Agip FORK 20W) is that their viscosity changes little with changes in temperature and their damping response therefore remains constant.

COOLANT

▲ CAUTION

Do not use the vehicle if the coolant is below the minimum prescribed level.

Before setting off, and every 2,000 km (1,228 mi), check the level of the coolant, see (CHECKING AND TOPPING UP); renew the coolant every two years, see (CHANGING THE COOLANT).

▲ WARNING

Coolant is poisonous! Do not ingest coolant under any circumstance.

Should you get coolant in your mouth, rinse with cool water and immediately seek medical attention. Coolant is also very dangerous to your skin and eyes. Should you accidentally get coolant on your clothing or skin, change clothes immediately.

Wash coolant from your skin with hot water and soap.

Should you get coolant in your eyes, flush with plenty of cool water and seek professional medical help at once.

Should someone swallow coolant accidentally, induce vomiting, rinse mouth with water, and immediately seek professional medical attention.

DISPOSE OF THE COOLANT PROPERLY.



BE SURE TO KEEP THE DRAINED COOLANT AWAY FROM CHILDREN AND PETS.

IT IS SWEET TASTING, AS WELL AS EXTREMELY POISONOUS, AND IS VERY ATTRACTIVE TO CHILDREN AND PETS.

Use extra caution not to spill the coolant on any hot parts of the engine. It is flammable, and can emit invisible, noxious fumes.

Always wear rubber or latex gloves when servicing the cooling system.

The coolant is made up of 50% water and 50% antifreeze.

This mixture is ideal for most running temperatures and ensures good protection against corrosion. It is advisable to keep the same mixture also in the hot season, since in this way losses due to evaporation are reduced and it is not necessary to top up very frequently.

The mineral salt deposits left in the radiator by evaporated water are thus reduced and the efficiency of the cooling system remains unchanged.

If the outdoor temperature is below 0°C, check the cooling circuit frequently and if necessary increase the antifreeze concentration (up to maximum 60%).

▲ CAUTION

Use only distilled water when topping off the cooling system. This will reduce damage to the engine.

▲ WARNING

The coolant is very hot.

Do not remove the filler cap (1) when the engine is hot since the coolant is under pressure and it will splash out violently.

If it gets in contact with the skin or with your clothing, it may cause severe burns.

▲ WARNING

Be aware of the risk of burns from the coolant. Check the coolant level and top up the expansion tank only after the engine has thoroughly cooled.

Do not use your fingers or any other object to check if there is enough coolant.

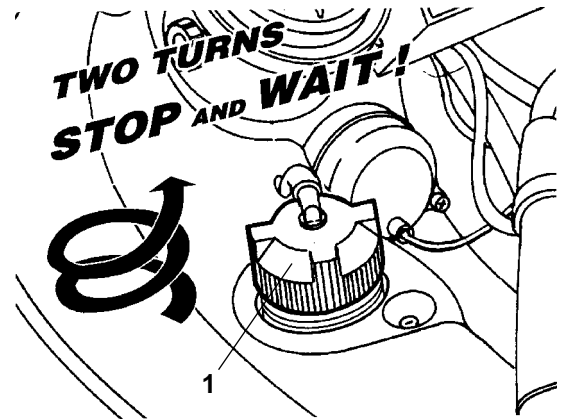

On the basis of the desired freezing temperature of the coolant mixture, add to the water the percentage of coolant indicated in the following table.

Freezing point °C (°F)	Coolant % of volume
-20° (-4°)	35
-30° (-22°)	45
-40° (-40°)	55

NOTE The characteristics of the various antifreeze liquids are different.
Be sure to read the label on the product to learn the degree of protection it guarantees.

▲ CAUTION

Use only antifreeze and anticorrosive without nitrite in order to ensure protection at least -35°C.

GEARBOX OIL

▲ CAUTION

Gearbox oil can cause serious skin damage if handled on a daily basis over a long period of time.
You are advised to wash your hands thoroughly after handling the oil.
Do not dispose of the oil in drains, water courses or the soil.
Take the oil to (or have it collected by) the nearest used oil disposal agency or the supplier.
You are advised to wear rubber gloves when carrying out maintenance work.

Change the gearbox oil after the first 500 km (312 miles) and then every 8000 km (5000 miles) (*), see (CHANGING THE GEARBOX OIL AND THE ENGINE OIL FILTER).

2 STROKE OIL

▲ CAUTION

2 stroke oil can cause serious skin damage if handled on a daily basis over a long period of time.
You are advised to wash your hands thoroughly after handling the oil.
Do not dispose of the oil in drains, water courses or the soil.
Take the oil to (or have it collected by) the nearest used oil disposal agency or the supplier.
You are advised to wear rubber gloves when carrying out maintenance work.

BRAKE FLUID

NOTE This motorcycle has front and rear disc brakes, with separate hydraulic circuits.
The following information refers to a single braking system, but is applicable to both.

▲ CAUTION

Brake fluid can cause irritation if it comes into contact with the skin or eyes.
Thoroughly wash any parts of the body that come into contact with the fluid and contact an eye specialist or doctor if the fluid comes into contact with the eyes.

DO NOT DISPOSE OF THE FLUID IN DRAINS, WATER COURSES OR THE SOIL.

KEEP OUT OF REACH OF CHILDREN.

Avoid splashing brake fluid on the plastic or painted parts of the motorcycle, as it will cause damage.
Check the brake fluid level every 4000 km (2500 miles), (CHECKING AND TOPPING UP THE FRONT BRAKE FLUID) and (CHECKING AND TOPPING UP THE REAR BRAKE FLUID); change the fluid every year, (CHANGING THE FRONT BRAKE FLUID) and (CHANGING THE REAR BRAKE FLUID).

▲ WARNING

Do not use fluids other than those specified and do not top up with different fluids, as this will damage the braking system.

Do not use fluids that have been stored in old containers or that have been open for a long time.

Sudden variations in the play or looseness of the brake levers are caused by problems in the hydraulic circuits.

Check very carefully to ensure that there is no oil or grease on the brake discs and friction gaskets, especially after servicing or inspections.

Check that the brake hoses are not twisted or worn.

Make sure no water or dust gets into the circuit accidentally.

You are advised to wear rubber gloves when working on the hydraulic circuit.

CARBON MONOXIDE

If a servicing operation has to be carried out with the engine running, make sure this is done in the open air or in a well-ventilated area.

Never run the engine in enclosed spaces. If you have to work in an enclosed space, use an exhaust fume extraction system.

▲ CAUTION

Exhaust fumes contain carbon monoxide, a poisonous gas that can cause loss of consciousness and death.

Run the engine in the open air or, if you have to work in an enclosed space, use an exhaust fume extraction system.

COMPONENTS AT HIGH TEMPERATURES**▲ CAUTION**

The engine and the exhaust system components get very hot and stay hot for a certain time after the engine has been switched off.

Wear heat-proof gloves if you have to handle these components, or else wait until the engine and exhaust system have cooled down.

RUNNING-IN RULES**▲ WARNING**

After the motorcycle has been operated for 500 km (300 mi), perform the checking operation shown in the column "After running-in" of the REGULAR SERVICE INTERVALS CHART.

Failure to heed this warning can lead to damage to your motorcycle, engine seizure or other malfunction which could cause an upset and lead to serious injury or even death.

The internal parts of the engine and transmission must be properly run-in to ensure their long life and dependable operation.

If possible, while breaking in your motorcycle, ride on hilly roads and/or roads with many curves so that the engine and transmission undergo lots of speed changes. It is also important that, during the run-in period, the suspension and brakes be treated gently to allow the mating parts to bed.

Therefore, avoid hard braking, high speeds or very bumpy roads during the break in period.

0- 100 km (0- 62 mi)

Apply the brakes gently, avoiding sudden or prolonged braking.

0- 300 km (0- 187 mi)

Open the throttle no more than one-half way for extended periods.

300- 500 km (187- 312 mi)

Open the throttle no more than three-quarters for extended periods.

POSITION OF THE WARNING ADHESIVE LABELS

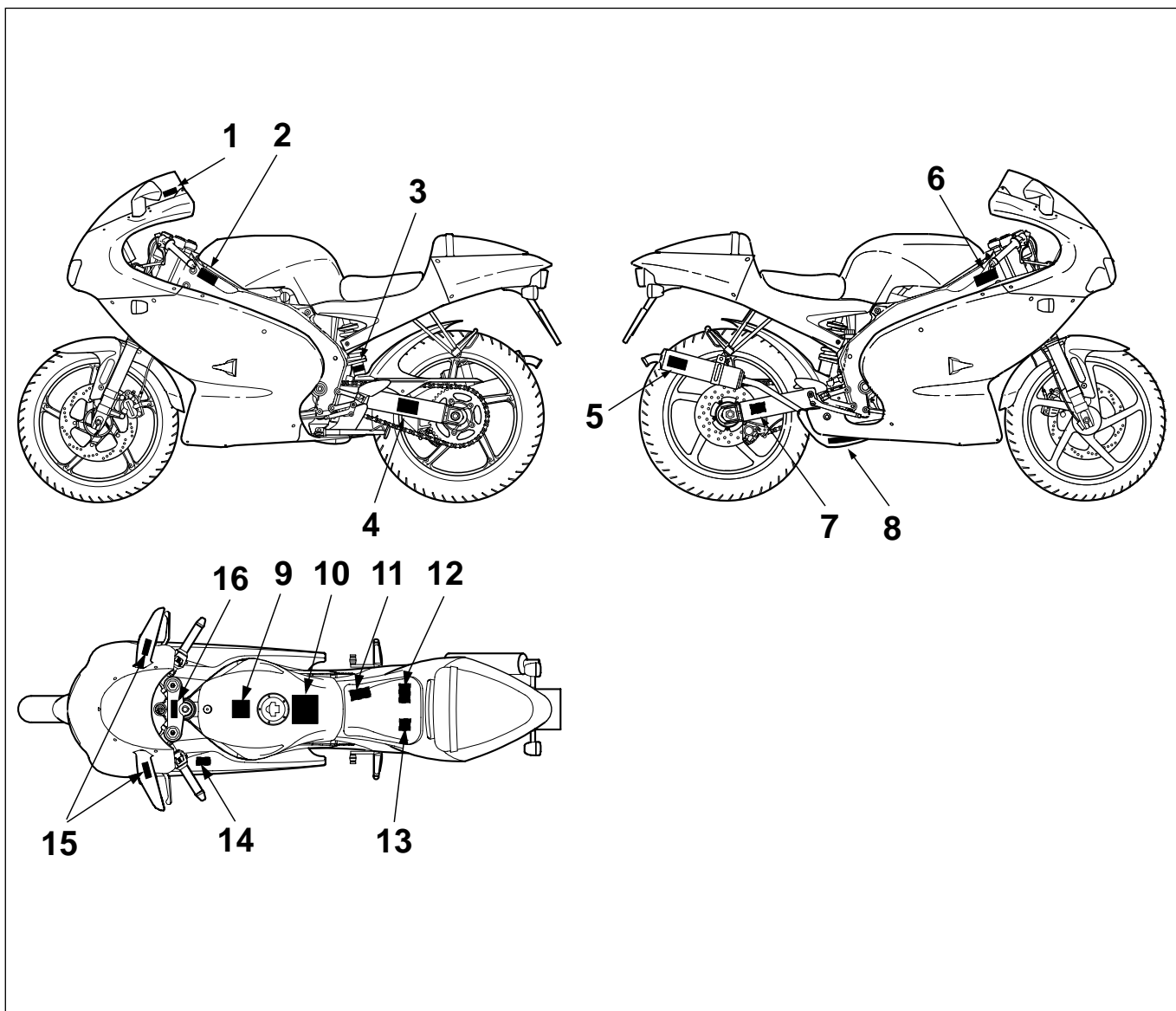

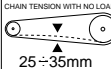
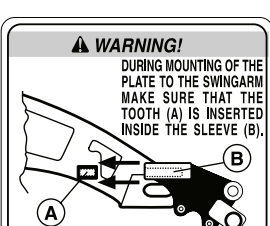
Ref.	Description																																										
1	<p>⚠ WARNING!</p> <ul style="list-style-type: none"> • Keep windshield clean at all times. • Clean only with a soft cloth and warm water with a mild detergent. • Replace windshield if becomes scratched or discoloured so as to interfere with view. • Do not allow any alkaline or strong acid cleaner, gasoline, brake fluid or any other solvent to contact the windshield. • When replacing windshield, use only Aprilia original replacement windshield. 																																										
2	<p>MOTORCYCLE NOISE EMISSION CONTROL INFORMATION THIS 1999 ASP21A0049 MOTORCYCLE, 8219489 MEETS EPA NOISE EMISSION REQUIREMENTS OF 80 dBA AT 9260 closing r.p.m. BY THE FEDERAL TEST PROCEDURE. MODIFICATIONS WHICH CAUSE THIS MOTORCYCLE TO EXCEED FEDERAL NOISE STANDARDS ARE PROHIBITED BY FEDERAL LAW. SEE OWNER'S MANUAL.</p>																																										
3	<p>⚠ WARNING!</p> <ul style="list-style-type: none"> • CONTAINS HIGH PRESSURE NITROGEN GAS. • SEE WORKSHOP MANUAL FOR DISPOSAL AND ADJUSTING UNIT. • DO NOT OPEN. DO NOT INCINERATE. INCINERATION, PUNCTURE OR DISASSEMBLY MAY CAUSE THIS UNIT TO EXPLODE. 																																										
4	<p>⚠ WARNING!</p> <p>Do not use any tire other than those recommended and approved by Aprilia. Maintain proper tire inflation. Do not use any tire with less than 1/8" (3mm) tread remaining. Do not repair any tire, nor use a repaired tire. Do not ride your motorcycle overloaded or with an unbalanced load. Failure to follow these warnings can lead to an accident and serious injuries or death. Always ensure that the chain is correctly adjusted. See owner's manual.</p> <p>CHAIN TENSION WITH NO LOAD</p>  <table border="1"> <thead> <tr> <th colspan="2">Tires pressure bar (psi)</th> <th colspan="2">Front tire</th> <th colspan="2">Rear tire</th> </tr> </thead> <tbody> <tr> <td>7</td> <td>1.9</td> <td>Pirelli Metzeler</td> <td>90/80 - 17" 46S</td> <td>Dunlop</td> <td>90/80 - 17" 46P</td> </tr> <tr> <td>(24.65)</td> <td>(27.55)</td> <td colspan="4"></td> </tr> <tr> <td>8</td> <td>2.1</td> <td colspan="4"></td> </tr> <tr> <td>(26.1)</td> <td>(30.45)</td> <td colspan="4"></td> </tr> <tr> <td>1.8</td> <td>2.1</td> <td colspan="4"></td> </tr> <tr> <td>(26.1)</td> <td>(30.45)</td> <td colspan="4"></td> </tr> </tbody> </table>	Tires pressure bar (psi)		Front tire		Rear tire		7	1.9	Pirelli Metzeler	90/80 - 17" 46S	Dunlop	90/80 - 17" 46P	(24.65)	(27.55)					8	2.1					(26.1)	(30.45)					1.8	2.1					(26.1)	(30.45)				
Tires pressure bar (psi)		Front tire		Rear tire																																							
7	1.9	Pirelli Metzeler	90/80 - 17" 46S	Dunlop	90/80 - 17" 46P																																						
(24.65)	(27.55)																																										
8	2.1																																										
(26.1)	(30.45)																																										
1.8	2.1																																										
(26.1)	(30.45)																																										
5	Exhaust pipe stamping.																																										
6	<p>Manufactured by Aprilia s.p.a.</p> <ul style="list-style-type: none"> ○ GVWR: 655.5 lbs. ○ GAWR: F 220 lbs with 90/80 - 17" 46S, 90/80-17" 46P tires, E - 17 x 2.50 - DOT - D rim, at 26 psi COLD ○ GAWR: R 435.5 lbs with 110/80 - 17" 57S, 110/80 - 17" 57P tires, E - 17 x 3.00 - DOT - D rim, at 30.5 psi COLD ○ This vehicle conforms to all applicable Federal Motor Vehicle Safety Standards in effect on the date of manufacture shown above. <p>MOTOR DRIVEN CYCLE</p>																																										
7	<p>⚠ WARNING!</p> <p>DURING MOUNTING OF THE PLATE TO THE SWINGARM MAKE SURE THAT THE TOOTH (A) IS INSERTED INSIDE THE SLEEVE (B).</p> 																																										
8	Muffler stamping.																																										

Ref.	Description																																											
9	<p>⚠ WARNING!</p> <ul style="list-style-type: none"> • Wear a helmet, eye protection, and bright protective clothing. • Don't ride after consuming alcohol or other drugs. • Slow down on slippery surface, unfamiliar terrain or when visibility is reduced. • Read owner's manual carefully • Failure to follow these warnings can lead to an accident and serious injuries or death. • USE UNLEADED FUEL. MINIMUM OCTANE RATING (R + M) / 2 METHOD 90. • See owner's manual for the correct running in and maintenance of the vehicle. 																																											
10	<p>⚠ WARNING!</p> <p>Do not install accessories or replacement parts not approved by Aprilia as original spare parts. Such installation can degrade the handling and safety of your motorcycle and can cause an accident with serious injury or death. See owner's manual.</p>																																											
11	<table border="1"> <tr> <td colspan="2">aprilia N°</td> <td>YEAR</td> <td>T</td> <td>V</td> <td>W</td> <td>X</td> <td>Y</td> </tr> <tr> <td colspan="2">SPARE PARTS CODE NUMBER</td> <td>LVL</td> <td>A</td> <td>B</td> <td>C</td> <td>D</td> <td>E</td> </tr> <tr> <td>I</td> <td>UK</td> <td>A</td> <td>P</td> <td>SF</td> <td>B</td> <td>D</td> <td>F</td> <td>GR</td> </tr> <tr> <td>NL</td> <td>CH</td> <td>DK</td> <td>J</td> <td>SGP</td> <td>PL</td> <td>IL</td> <td>ROK</td> <td>MAL</td> </tr> <tr> <td>BM</td> <td>AUS</td> <td>USA</td> <td>BR</td> <td>RSA</td> <td>NZ</td> <td>CDN</td> <td>HR</td> <td>SLO</td> </tr> </table>	aprilia N°		YEAR	T	V	W	X	Y	SPARE PARTS CODE NUMBER		LVL	A	B	C	D	E	I	UK	A	P	SF	B	D	F	GR	NL	CH	DK	J	SGP	PL	IL	ROK	MAL	BM	AUS	USA	BR	RSA	NZ	CDN	HR	SLO
aprilia N°		YEAR	T	V	W	X	Y																																					
SPARE PARTS CODE NUMBER		LVL	A	B	C	D	E																																					
I	UK	A	P	SF	B	D	F	GR																																				
NL	CH	DK	J	SGP	PL	IL	ROK	MAL																																				
BM	AUS	USA	BR	RSA	NZ	CDN	HR	SLO																																				
12	<p>⚠ WARNING!</p> <p>Contain sulfuric acid which can cause severe injuries. Avoid contact with skin, eyes or clothing. Antidote: EXTERNAL - Flush with water. INTERNAL - Drink large quantities of water or milk. Follow with milk of magnesia, beaten egg or veg. oil. Call physician immediately. Eyes: Flush with water for 15 minutes and get prompt medical attention. KEEP OUT OF REACH OF CHILDREN. Batteries produce explosive gases. Keep sparks, flames, cigarettes away. Charge only in well-ventilated space. Always wear protective goggles when working around batteries. Always connect the battery vent tube. Failure to heed this warning will cause corrosion of the electrical system.</p>																																											
13	<p>aprilia BATTERY SERVICE</p> <p>⚠ WARNING!</p>  <p>Maintain electrolyte level between the two level marks. Use only distilled water. Always keep the battery charged. Never disconnect the battery or regulator with the engine running. This will destroy the entire electrical system.</p>																																											
14	<p>⚠ WARNING!</p> <p>COOLANT</p> <p>USE ONLY FLUID FOR SEALED CIRCUITS. USE ONLY ANTIFREEZE AND ANTICORROSIVE WITHOUT NITRITE. ENSURING PROTECTION AT -35° C AT LEAST.</p>																																											
15	OBJECTS IN MIRROR ARE CLOSER THAN THEY APPEAR.																																											
16	<p>⚠ WARNING!</p> <p>DO NOT ALLOW KEY CHAIN AND ANY OTHER ITEM TO FALL BETWEEN THE STEERING HEAD AND THE BODY OF MOTORCYCLE. THIS CAN CAUSE LOSS OF CONTROL.</p>																																											

SPARE PARTS

If any parts have to be replaced, use only original **aprilia** spare parts.

aprilia original spare parts are high quality and have been designed and built specifically for **aprilia** motor cycles.

▲ WARNING

The use of **NON-original aprilia replacement parts may impair the motorcycle's performance, and even can cause lasting damage. Damage caused by the use of NON-original spare parts is not covered by the warranty.**

TECHNICAL DATA

DIMENSIONS	
Max. length	1920 mm (75.6 in)
Max. length (with rear mudguard extension OPT)	1985 mm (78.1 in)
Max. width	675 mm (26.6 in)
Max. height (to front fairing)	1155 mm (45.5 in)
Seat height	810 mm (31.9 in)
Wheelbase	1280 mm (50.4 in)
Min. ground clearance	170 mm (6.7 in)
Curb weight	115 Kg (253.5 lbs)





ENGINE	
Type	one- cylinder, 2- stroke with laminar suction. Separate lubrication with variable strength automatic mixer (1.0 - 3.0%).
Number of cylinders	1
Total displacement	49.75 cm ³ (1.7 US fl oz)
Bore / stroke	40.3 mm / 39.0 mm (1.6 in / 1.5 in)
Compression ratio	12 ± 0.5 : 1
Starting	electric
Engine idling rpm	1,100 ± 100 giri/min (rpm)
Clutch	multidisc in oil bath, with manual control on the left side of the handlebar.
Cooling	liquid-cooled

CAPACITY	
Fuel (reserve included)	13 / (3.4 gal)
Fuel reserve	2.6 / / 0.69 gal (mechanical reserve)
Transmission oil	820 cm ³ (28 US fl oz)
Coolant	0.9 / (0.24 gal) (50% water+50% antifreeze with ethylene glycol)
2 stroke oil (reserve included)	1.6 / (1.69 qt)
2 stroke oil reserve	0.35 / (0.37 qt)
Front fork oil	430 cm ³ (14.5 US fl oz) (for each fork leg)
Seats	n° 1 (2 in countries where passenger can be carried)
Motorcycle max. load (driver+ luggage)	105 Kg (231.5 lbs)
Motorcycle max. load (driver+ passenger+ luggage)	180 Kg / 396.8 lbs (in countries where passenger can be carried)

TRANSMISSION	
Type	mechanical, 6 gears with foot control on the left side of the engine

GEAR RATIOS	
Ratio	
Primary	1 st 20/ 71 = 1 : 3.550
Secondary	12 / 36 = 1 : 3.000
Final ratio	12 / 47 = 1 : 3.916
Total ratio	1 : 41.712

CONTINUED >

GEAR RATIOS	
Ratio 2°	
Secondary	2 nd 16 / 33 = 1: 2.062
Total ratio	1:28.677
Ratio 3°	
Secondary	3 rd 19 / 29 = 1: 1.526
Total ratio	1:21.222
Ratio 4°	
Secondary	4 th 22 / 27 = 1: 1.227
Total ratio	1:17.064
Ratio 5°	
Secondary	5 th 24 / 25 = 1: 1.042
Total ratio	1:14.483
Ratio 6°	
Secondary	6 th 25 / 24 = 1: 0.960
Total ratio	1:13.348
CARBURETOR	
Number	1
Model	DELLORTO SHA 14/12
FUEL SUPPLY	
Fuel	Super-rated unleaded petrol (4-star ) or unleaded petrol with minimum octane rating 95 (N.O.R.M.) and 85 (N.O.M.M.)
Fuel   	unleaded petrol in compliance with DIN 51 607, with minimum octane rating 95 (N.O.R.M.) and 85 (N.O.M.M.)
FRAME	
Type	perimeter aluminum backbone
Rake	24°C (- 75°F)
Trail	102 mm (4 in)
SUSPENSIONS	
Front	hydraulically operated telescopic fork
Wheel stroke	4.3 in (110 mm)
Rear	hydraulic adjustable mono- shock absorber
Wheel stroke	4.7 in (120 mm)
BRAKES	
Front	disc brake - Ø 280 mm (Ø 11.02 in) - with hydraulic actuation
Rear	disc brake - Ø 220 mm (Ø 8.66 in) - with hydraulic actuation
WHEEL RIMS	
Type	light alloy
Front	2.50 x 17"
Rear	3.00 x 17"
TIRES	
Front	90/80 17" 46S; 90/80 17" 46P
Rear	110/80 17" 57S; 110/80 17" 57P
INFLATION PRESSURE FOR SOLO RIDER	
Front	170 kPa (24.6 Psi / 1.7 bar)
Rear	190 kPa (27.5 Psi / 1.9 bar)
INFLATION PRESSURE FOR RIDER AND PASSENGER (in countries where passenger can be carried)	
Front	180±10 kPa (1.8±0.1 bar / 26±1.45 Psi)
Rear	210±10 kPa (2.1±0.1 bar / 30.4±1.45 Psi)
IGNITION	
Type	C.D.I.
Spark advance	20° ± 1° (68°F ± 34°F) before TDC

CONTINUED >



SPARK PLUG	
Standard	NGK R BR9ES
Alternative	CHAMPION RN1C
	NGK R BR8ES
Spark plug gap	0.6 - 0.7 mm (0.02 - 0.03 in)

ELECTRIC	
Battery	12 V - 4 Ah
Fuses	7.5 A
Generator	12 V - 105 W

BULBS	
Low beam	12 V - 35 W
High beam	12 V - 35 W
Parking light	12 V - 5 W
Direction indicators	12 V - 10 W
Rear parking light/ number/ plate light/ stoplight	12 V - 5 / 21 W
Tachometer	12 V - 5 W
Speedometer	12 V - 3.4 W
Coolant temperature indicator	12 V - 1.2 W

WARNING LIGHTS	
Neutral	12 V - 1.7 W
Right direction indicators	12 V - 1.7 W
High beam	12 V - 1.7 W
2 stroke oil reserve	12 V - 1.7 W
Left direction indicators	12 V - 1.7 W
Low beam	12 V - 1.7 W

LUBRICANT CHART

Gearbox oil (recommended):  F. C., SAE 75W - 90 or  GEAR SYNTH, SAE 75W - 90.





As an alternative to the recommended oil, it is possible to use high-quality oils with characteristics in compliance with or superior to the A. P. I. GL- 4 specifications.

2 stroke oil (recommended):  PRO GPX 2 or  2T FORMULA RACING.



As an alternative to the recommended oil, use high- quality oils with characteristics in compliance with or superior to the ISO- L- ETC ++, A. P. I. TC ++ specifications.



Fork oil (recommended):  F. A. 5W or  F. A. 20W fork oil.;



As an alternative  FORK 5W or  FORK 20W.

To obtain an intermediate setting between the  F. A. 5W and  F. A. 20W or  FORK 5W and  FORK 20W levels, the products can be mixed in the proportions shown below:

SAE 10W =  F. A. 5W 67% of the volume +  F. A. 20W 33% of the volume, or

 FORK 5W 67% of the volume +  FORK 20W 33% of the volume;



SAE 15W =  F. A. 5W 33% of the volume +  F. A. 20W 67% of the volume, or

 FORK 5W 33% of the volume +  FORK 20W 67% of the volume.

Bearings and other lubrication points (recommended):  AUTOGREASE MP or  GREASE 30.

As an alternative to the recommended product, use high-quality grease for rolling bearings, working temperature range -30° C.... +140° C (86°F...+ 284°F), dripping point 150° C... 230° C (302°F... 446°F), high protection against corrosion, good resistance to water and oxidation.

Protection of the battery poles: neutral grease or vaseline.

Spray grease for chains (recommended):  CHAIN SPRAY or  CHAIN LUBE.

▲ WARNING

Use new brake fluid only. Use of used or contaminated brake fluid can lead to brake failure with subsequent accident, serious injury, or even death.

Brake fluid (recommended):  F. F., DOT 5 (DOT 4 Compatible) or  BRAKE 5.1, DOT 5 (DOT 4 Compatible).

▲ WARNING

Use only antifreeze and anticorrosive without nitrite, ensuring protection at least -35°C (-31°F).

Engine coolant (recommended):  ECOBLU - 40°C (- 40°F) or  COOL.

Failure to use appropriate antifreeze, mixed with distilled water, as coolant, can lead to serious damage to the motorcycle's cooling system, which can cause engine seizure, and subsequent upset with serious injury or even death.

SPECIAL TOOLS OPT

Special service tools must be used for removing and fitting components correctly and for certain adjustments.

The special tools will avoid the damage that can occur using unsuitable tools and/or improvised techniques. Below is the list of service tools specially designed for this specific motorcycle.

If necessary, ask for the general service tools (see service tools manual).

▲ WARNING

Consult the accompanying documentation (if any) before using the special tools.

Code	Pos.	Name of tool and function
8140204	1	Support pin for stand
8705021	2	Rear stand
8101945	3	Swing arm pin adjustment socket wrench

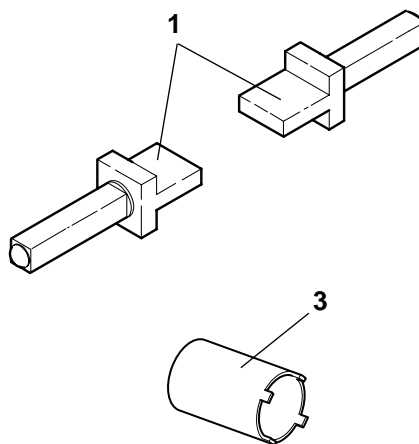
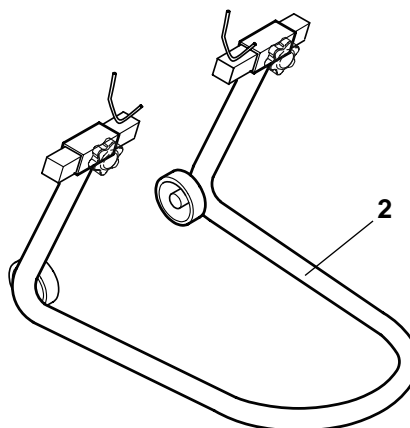

POSITIONING THE MOTORCYCLE ON THE REAR SUPPORT STAND

Loosen the knob (1).
Remove the front fork support (2) from the stand.
Insert the support pin (3).
Repeat the previous operations on the opposite side of the stand.

⚠ WARNING

Lift the motorcycle by grasping the two sides of the swing arm only.

Support pin for stand: 8140204.

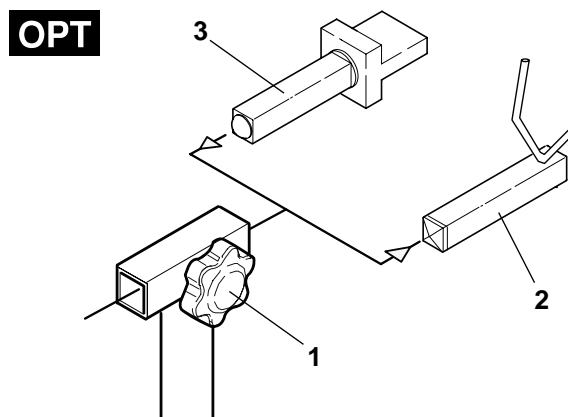

Insert the stand from the back of the motorcycle and position it so that the two support pins (3) can be located as follows:
the right support between the brake caliper and brake line coupling on the swing arm (**Pos. A**);
the left support between the sprocket and chain (**Pos. B**);
Slide the support pins (3) towards the motorcycle, so that the bosses on the pins touch the swing arm (see figure above).
Tighten the two knobs (1).

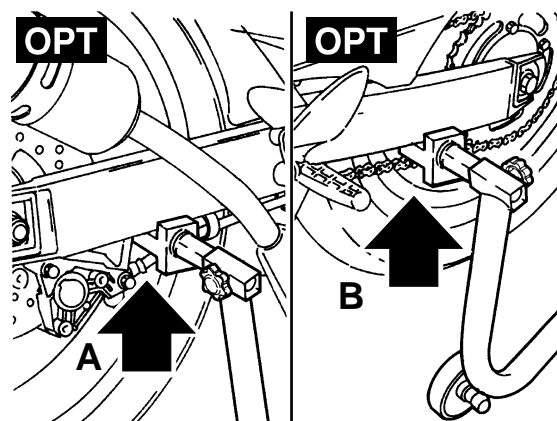

NOTE Have someone help you keep the motorcycle in vertical position with the two wheels on the ground.

Rest one foot on the rear part of the stand (4).
Push the stand (4) downwards until it reaches the end of its stroke (see figure).

Rear stand: 8705021.

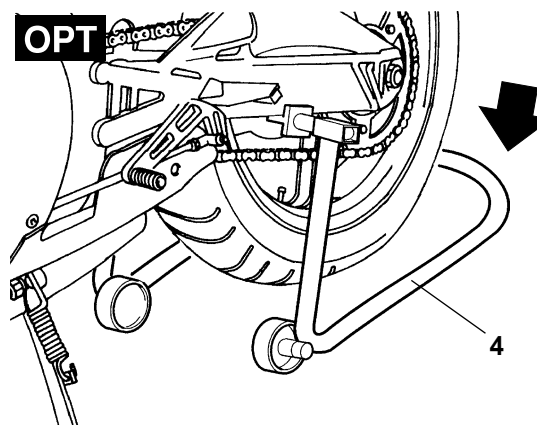

GENERAL SPECIFICATIONS FOR TORQUE WRENCH SETTINGS

The standard torque wrench settings for screws and bolts with ISO metric thread are given in the table below.

Thread screw or bolt	Wrench	Torque wrench	
		Nm (Ft-lb)	Kgm
M6	10	6 (4.4)	0,6
M8	12	15 (11.1)	1,5
M10	14	30 (22.1)	3,0
M12	17	55 (40.5)	5,5
M14	19	85 (62.7)	8,5
M16	22	130 (95.9)	13,0

For the specific settings for the unions and couplings on the motorcycle in question, see (FASTENERS).

Unless otherwise specified, the torque wrench settings refer to clean, dry threads at ambient temperature.



1

NOTE To avoid deforming the components, or having a leaking joint, tighten the screws and bolts as follows. First, screw in all the fasteners by hand. Second, snug each fastener to approximately one-half of the specified torque setting, working in the diagonal pattern as shown, (A), (B), (C), and (D). Finally, bring each fastener up to its specified torque, working in the same order.

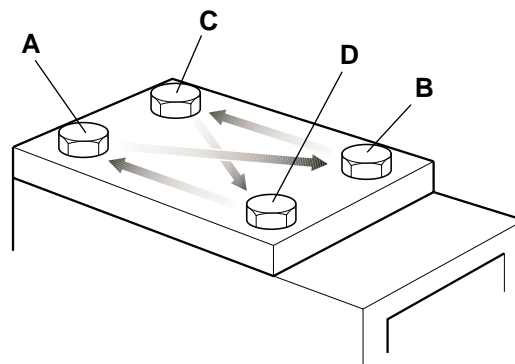

NOTE When this procedure is followed, the clamping pressure exerted by the fasteners will be uniformly distributed over the surface of the joint.

ABBREVIATIONS / SYMBOLS / INITIALS

#	= number	/	= liters
<	= less than	LED	= light emitting diode
>	= greater than	m/s	= meters / second
≤	= equal to or less than	MAX	= maximum
≥	= equal to or greater than	mbar	= millibar
~	= approximately	mi	= mile
∞	= infinity	MIN	= minimum
°C	= degrees Centigrade	MPH	= miles per hour
°F	= degrees Fahrenheit	MΩ	= megaohm
±	= plus or minus	N.O.M.M.	= "Motor" method octane rating
a.c.	= alternating current	N.O.R.M.	= "Research" method octane rating
A	= Ampere	Nm	= Newton-meter (1 Nm = 0.1 kgm)
Ah	= Ampere-hour	Ω	= ohm
API	= American Petroleum Institute	PICK-UP	= pick-up
AT	= high tension (HT)	PMI	= bottom dead center (BDC)
bar	= unit of pressure (1 bar = 100 kPa)	PMS	= top dead center (TDC)
c.c.	= direct current (d.c.)	rpm	= revolutions per minute
cm³	= cubic centimeters	SAE	= Society of Automotive Engineers
CO	= carbon monoxide	TEST	= diagnostic check
DIN	= Deutsche Industrie Norm	T.C.E.I.	= hex socket screw
d.c.	= direct current	T.E.	= hex head screw
giri/min	= revolutions per minute (rpm)	T.P.	= slotted head screw
HC	= unburnt hydrocarbons	UPSIDE-	
ISC	= idle speed control	DOWN	= Upside-down forks
kg	= kilograms	V	= Volts
kgm	= kilograms per meter (1 kgm = 10 Nm)	W	= Watts
km	= kilometers	Ø	= diameter
km/h	= kilometers per hour		
k	= kilohm		
kPa	= kiloPascal (1 kPa = 0.01 bar)		
kW	= kilowatt		

**Routine maintenance
operations**

2

This section describes the routine maintenance procedures for the main components of the motorcycle.

▲ CAUTION

Before starting any maintenance or inspection job on the motorcycle, stop the engine and remove the key, and wait until the engine and exhaust system have cooled down. Place the motorcycle on a workstand, which is solidly attached to the floor. Raise the motorcycle up to the point where it may conveniently be worked on.

Use extreme caution when working around parts of the engine and exhaust, or brakes, which may remain hot for a long time.

Avoid the temptation to hold any part of the motorcycle in your mouth. Coatings and plainings are used on many of the parts used in this motorcycle, which are poisonous.

Unless expressly stated otherwise, reassemble the motorcycle in the reverse order from the disassembly steps given in this manual.



SERVICING SCHEDULE

	COMPONENT	End of running-in 1000 km (625 mi)	every 4000 km (2500 mi) or 12 months	every 8000 km (5000 mi) or 24 months
u	Battery electrolyte level	C	C	
u	Spark plug	P	C	S
c	Carburetor			P
c	Wheel balancing		C	
c	Steering sleeve bearings and steering play	C	C	
c	Wheel bearings		C	
u	Air cleaner	C	P	
u	Lights functioning / adjustment		C	
u	Clutch play	R	R	
c	Brake systems	C	C	
c	Cooling system	C	C	
u	Light system	C	C	
u	Brake fluid		C	
c	Brake fluid		every 2 years: S	
u	Coolant		every 2000 km (1250 mi): C	
c	Coolant		every 2 years: S	
u	2 stroke oil level		every 500 km (312 mi): C	
c	Exhaust pipe / muffler		P	
u	Gearbox oil	S	C	S
c	Fork oil and seal		every 12000 km (7500 mi): S	
c	Piston and piston rings		After first 8000 km (5000 mi): C / every 16000 km (10000 mi): S	
u	Engine idling speed	R	C	
u	Wheels / tires and inflation pressure		every month: C	
c	Wheels / tires and inflation pressure	C	C	
c	Tightening nuts and bolts	C	C	
c	2 stroke oil reserve warning light	C	C	
u	Drive chain tension and lubrication		every 500 km (312 mi): C	
c	Final drive (chain, ring gear, sprocket)		C	
c	Fuel lines		C	every 4 years: S
c	2 stroke oil pipes / hoses		C	every 4 years: S
u	Front and rear brake pad wear	C	every 2000 km (1250 mi): C	
c	Clutch wear		C	
c	Rear shock absorber			C
c	Brake discs	C	C	
c	Transmission and control cables	C	C	
c	Motorcycle general working order	C	C	

C = check and clean, adjust, lubricate or replace if necessary; P = clean; S = replace; R = adjust.

Service the motorcycle more frequently if it is used in rainy or dusty areas or on rough roads.

*Servicing of items marked (c) should be done ONLY by an authorized **aprilia** dealer.*

u = user c = dealer

LUBRICATION POINTS

Regular, lubrication, using the correct lubricants, is an important factor in ensuring the long life and excellent performance of the motorcycle.

IMPORTANT Before lubricating any part of the motorcycle, clean any rust, dirt, or dust from the part which is to be lubricated. Any exposed parts subject to rusting, must be lubricated with engine oil or grease (see LUBRICANT CHART).

The "LUBRICATION DIAGRAM" shows the lubrication points.

KEY TO LUBRICATION DIAGRAM

- 1) Throttle control
- 2) Throttle cable
- 3) Brake lever pin
- 4) Tachometer cable
- 5) Tachometer drive
- 6) Mounting pin
- 7) Brake pedal pins
- 8) Steering bearings
- 9) Clutch lever pin
- 10) Drive chain
- 11) Shift lever pins
- 12) Shift lever pins
- 13) Side stand pin

■ = Grease
▲ = Oil

LUBRICATION DIAGRAM

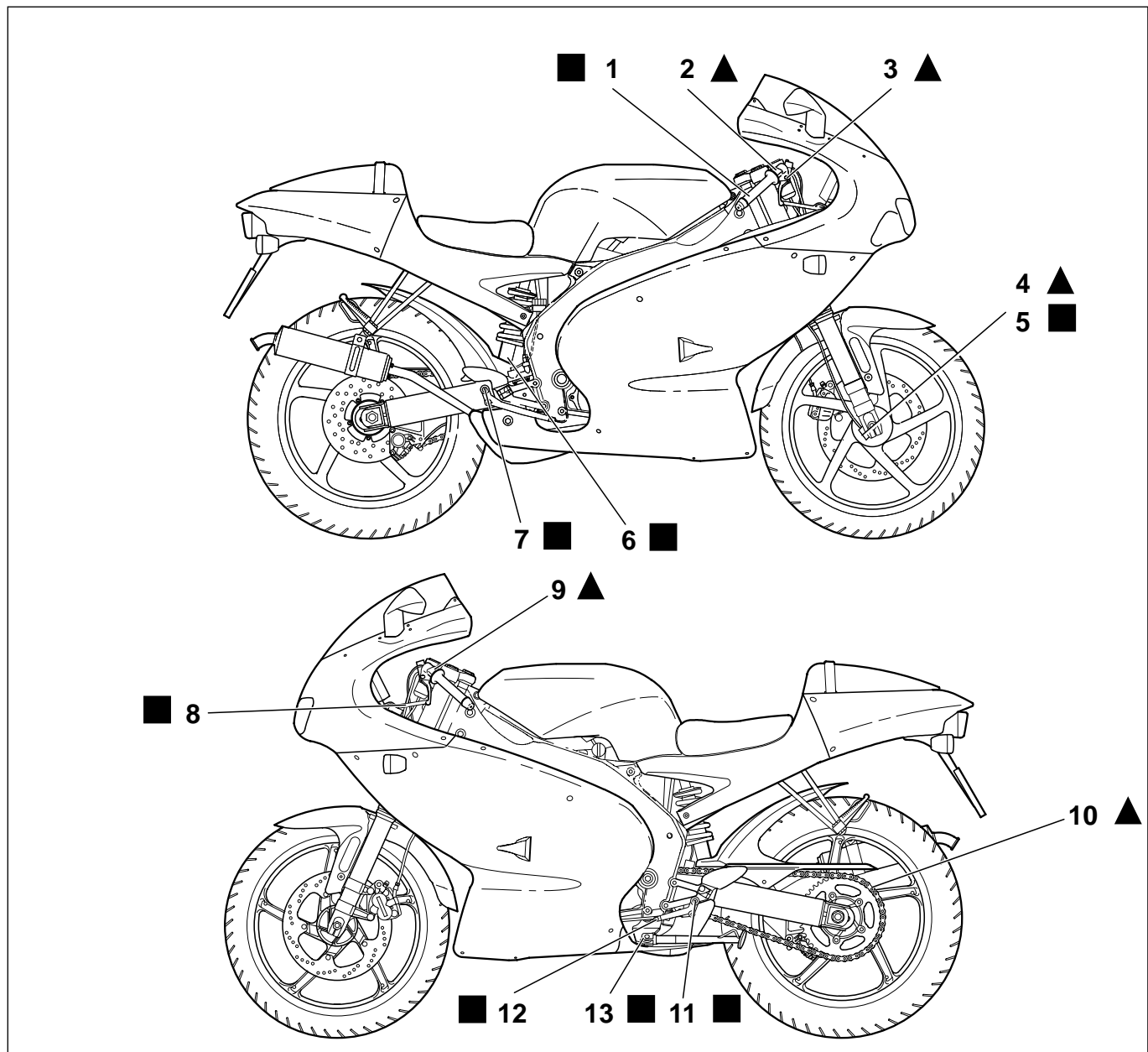

ARRANGEMENT OF THE INSTRUMENTS / CONTROLS

KEY

- 1) Ignition switch/ steering lock (⊙ - ⊗ - ⚡)
 - 2) Turn signal switch (↔)
 - 3) Horn push button (🔊)
 - 4) Dimmer switch (👁️ - 👁️)
 - 5) High beam signalling push button (👁️)
 - 6) Clutch lever
 - 7) Instruments and indicators
 - 8) Front brake lever
 - 9) Throttle grip
 - 10) Start push button (🔌)
 - 11) Light switch (⊙ - 📡 - •) (not present **ASD**)
 - 12) Engine stop switch (⊙ - ⊗)
- (in countries where installed)

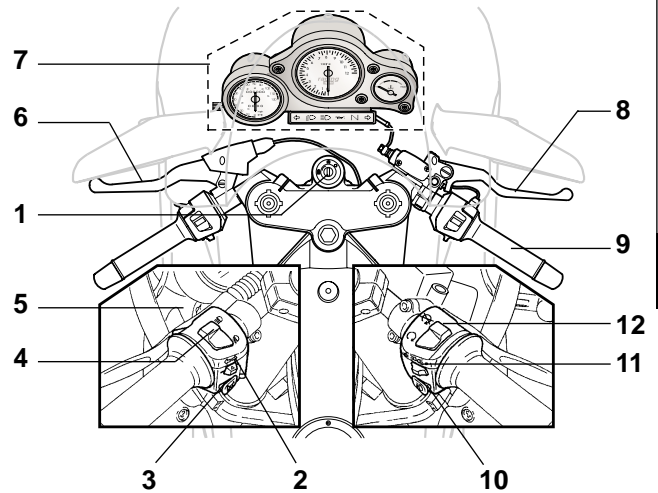

2

INSTRUMENTS AND INDICATORS

KEY

- 1) Tachometer
- 2) Coolant temperature indicator (🌡️)
- 3) Right turn signal (↔) (*)
- 4) Green neutral indicator warning light (N)
- 5) Red 2 stroke oil reserve warning light (🛢️)
- 6) Blue high beam warning light (👁️)
- 7) Green low beam warning light (👁️)
- 8) Left turn signal (↔) (*)
- 9) Trip odometer
- 10) Odometer reset
- 11) Total miles odometer
- 12) Speedometer

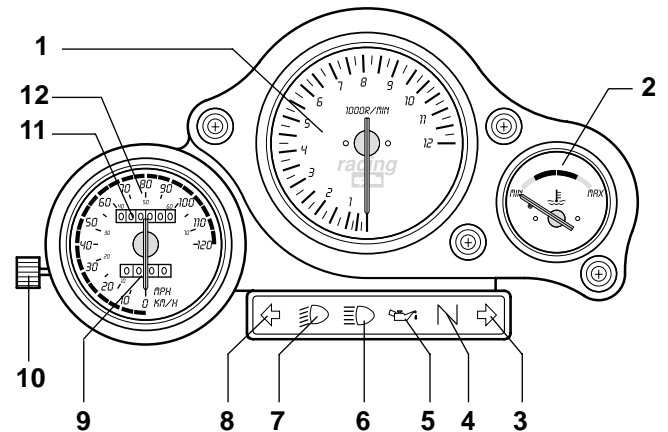

(*) The turn signal lights are yellow.

BATTERY

Read carefully (GENERAL PRECAUTIONS AND INFORMATION).

Two types of batteries are sold for motorcycles: conventional, which has a removable cap on each cell, and maintenance free, which has no removable caps and cannot be inspected.

⚠ CAUTION

This motorcycle is equipped with a conventional type battery. Do not replace it with a maintenance free battery. Doing so will damage the electrical system and could lead to a dangerous explosion.

Check the electrolyte level and the tightness of the terminals after the first 500 km (312 mi) and thereafter every 4,000 km (2,500 mi) or 8 months.

⚠ WARNING

Batteries, when charged, give off hydrogen gas, which is highly explosive. Therefore, do not smoke while working on or around the battery, and keep naked flames or sparks away from the battery. Keep gasoline and other flammable substances well away from the battery, since a battery spark could easily ignite them and cause a devastating fire. Battery electrolyte is toxic and caustic and can severely burn your eyes or skin. Always wear tight fitting goggles and protective clothing when handling battery electrolyte. It is particularly important for you to protect your eyes since even a minuscule amount of battery acid could destroy your vision. Should you accidentally get even the smallest amount of battery electrolyte on your skin or eyes, immediately flush with large quantities of clear cool water and immediately seek professional medical attention.

If someone should accidentally swallow battery electrolyte, drink a large quantity of milk or cool clear water and continue with milk of magnesia or vegetable oil. Seek professional medical assistance immediately.

Since the battery gives off explosive hydrogen gas, especially when it is being charged, when you are charging a battery, make sure that the room is properly ventilated. Do not inhale the gases released during charging. Do not permit any open flames, sparks or cigarettes or any other source of heat anywhere near the battery while it is charging. Do not tip the motorcycle too much, or tip the battery too much, to avoid electrolyte leaking out. Should you accidentally spill battery electrolyte on any part of your motorcycle, immediately wash it off with lots of cool clear water.

Spills may be neutralized with a mixture of baking soda and water, as well. This is particularly important, as the battery electrolyte will severely corrode metallic parts and destroy the finish of plastic and painted parts.

⚠ CAUTION

Never switch the battery cables. Observe the proper polarity of the battery. Incorrectly attaching the battery to your motorcycle will irreparably destroy the electrical system of your motorcycle. Connect and disconnect the battery only with the ignition switch (1) in the "⊗" (OFF) position. First connect the positive cable (+), then the negative (-). Disconnect the negative cable (-) first, then the positive (+).

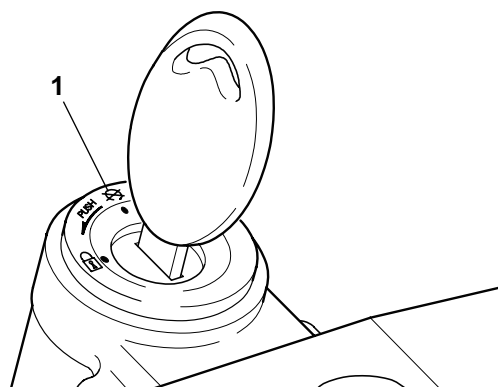
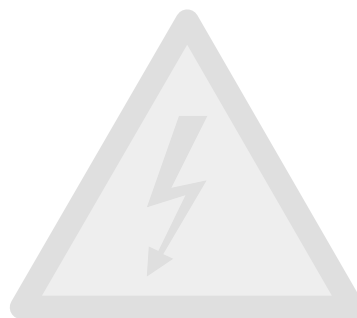

If your battery needs to be charged, use a constant voltage, or “taper” charger, with a current rating no greater than 1/10th the capacity of the battery (i. e., for a 50 amp hour battery, the maximum charging current should be 5 amps). Use of a more powerful charger can not only damage the battery irreparably, but could cause it to overheat and explode. If your battery is equipped with an overflow tube, always ensure that it is properly installed, and properly routed. Failure to adhere to this instruction can cause corrosive fumes from the battery to cause serious damage to your motorcycle.

NOTE Check the battery voltage with a portable tester. If the voltage reading is less than 12V, the battery needs recharging.

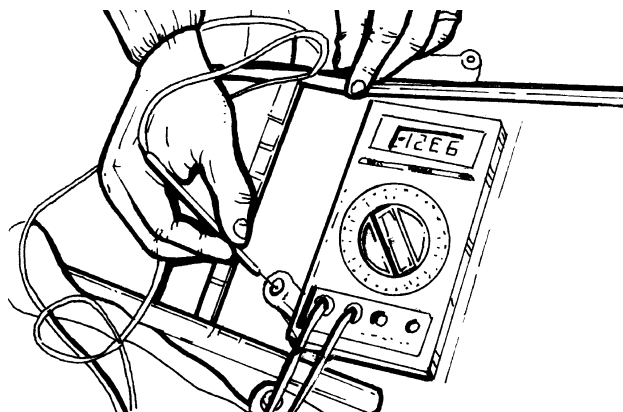

CHECKING AND CLEANING THE TERMINALS

Read carefully (BATTERY).

Remove the rider saddle (REMOVING THE RIDER SADDLE).
 Make sure that the cable terminals (1) and the battery terminals (2) are:
 in good conditions (and not corroded or covered with deposits);
 covered with neutral grease or Vaseline.
 If it is necessary to clean the battery terminals:
 Make sure that the ignition switch (3) is in “⊗” (OFF) position.
 Disconnect first the negative (-) and then the positive cable (+).
 Brush with a wire brush to eliminate any sign of corrosion.
 Reconnect first the positive (+) and then the negative cable (-).
 Cover the terminals of the cables and of the battery with neutral grease or Vaseline.

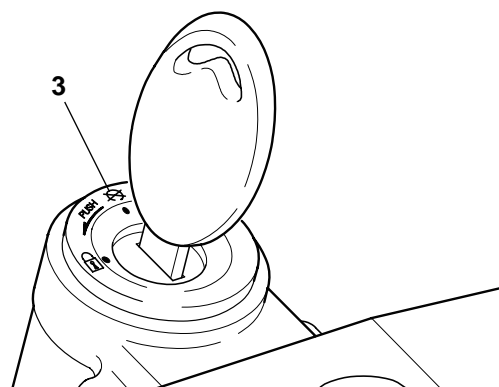
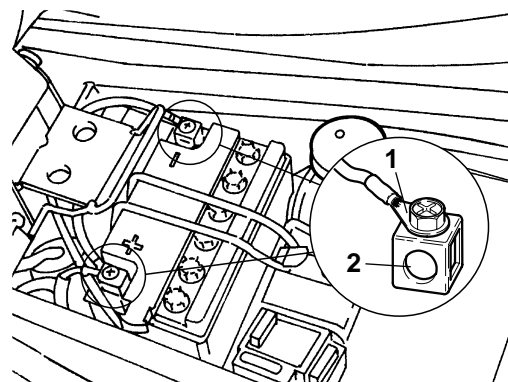

REMOVING THE BATTERY

Make sure that the ignition switch (3) is in “⊗” (OFF) position.
 Remove the rider saddle (REMOVING THE RIDER SADDLE).
 Release the rubber band (4) from the couplings (5) and (6) and take it.
 Disconnect first the negative (-) and then the positive cable (+). Remove the battery breather pipe (7). Remove the battery from its compartment and put it on a flat surface, in a cool and dry place.

▲ WARNING

Once it has been removed, the battery must be stored in a safe place. Ensure that children cannot find it; the slightest bit of battery acid spilled on the skin, eyes, or ingested can cause serious injury or even death.

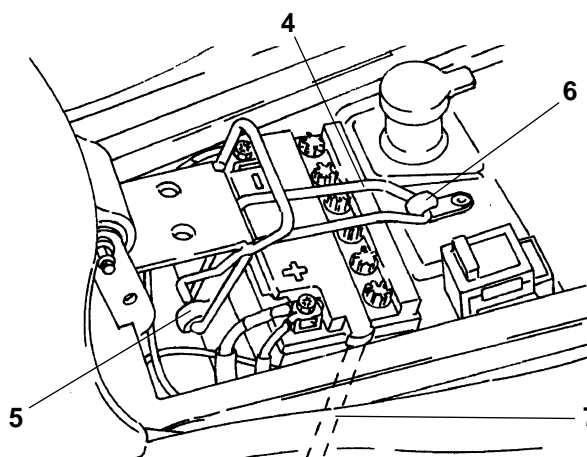

CHECKING THE ELECTROLYTE LEVEL

Read carefully (BATTERY).

To check the electrolyte level, proceed as follows:
 Remove the battery (REMOVING THE BATTERY).
 Make sure that the fluid level falls between the "MIN" and "MAX" notches stamped on the side of the battery.

If it does not:
 Remove the battery plugs.

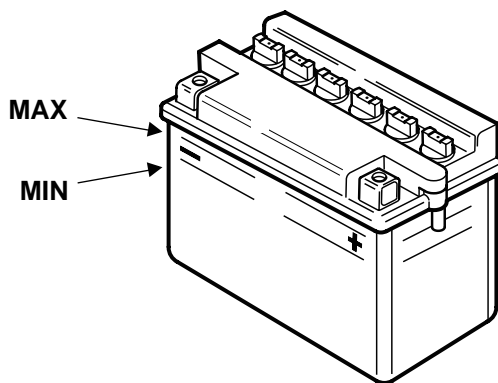

▲ CAUTION

Top up with distilled water only. Do not exceed the "MAX" mark, since the electrolyte level increases during the recharge.

Top up by adding distilled water.

RECHARGING THE BATTERY

Remove the battery, see (REMOVING THE BATTERY).
 Remove the battery plugs.

▲ WARNING

The battery gives off noxious and explosive gases; keep it away from flames, sparks, cigarettes and any other sources of heat. During the recharging or the use, make sure that the room is properly ventilated and avoid inhaling the gases released.

Check the electrolyte level, see (CHECKING THE ELECTROLYTE LEVEL).
 Connect the battery charger to the battery.
 Charge the battery using a battery charger with a current capacity of no greater than 1/10th the capacity of the battery.
 After the battery is fully charged, check the electrolyte level again and if necessary top up with distilled water.
 Replace the battery plugs.

Recharging	Voltage (Amps)	Time (hours)
Normal	1.2	8 - 10
Fast	12	0.5

▲ CAUTION

Do not replace the battery plugs until 10 minutes after disconnecting the charger, since the battery continues to produce gas after the charger is removed.

INSTALLING THE BATTERY

Make sure that the ignition switch (1) is in the OFF position.

Remove the rider saddle see (REMOVING THE RIDER SADDLE).

Install the battery in the battery box.

Connect the battery breather tube.

⚠ CAUTION

Reconnect the battery breather tube (see BATTERY).

Connect, in order, the positive (+) and negative (-) cable.

Cover the terminals of the cables and of the battery with neutral grease or Vaseline.

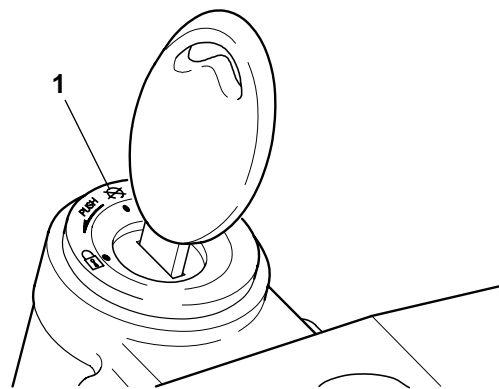

2

NOTE First hook the rubber strap into the lower hook (2) and then, into the upper hook (3).

Replace the rubber over the hook, taking care to position it correctly.

Replace the rider saddle, see (REMOVING THE RIDER SADDLE).

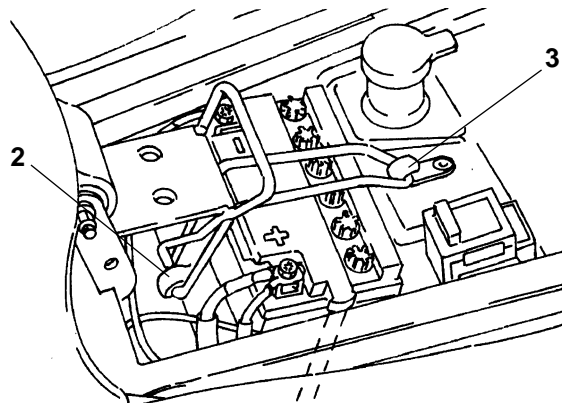

LONG PERIOD OF BATTERY NON-USE

If your motorcycle remains unused for more than a couple of weeks, it will be necessary to "trickle charge" the battery, to prevent battery damage, see (RECHARGING THE BATTERY). Remove the battery, see beside (REMOVING THE BATTERY), and put it in a cool, dry place.

The best way to prevent battery deterioration is to constantly leave a "trickle" charger with a capacity of about 1/10th amp, attached. These chargers are very economically available from your Local aprilia Dealer, and will ensure that your battery always remains in tip top condition. If this cannot be done, charge the battery for about 30 minutes using a battery charger with a current capacity of no greater than 1/10th the capacity of the battery, see (RECHARGING THE BATTERY).

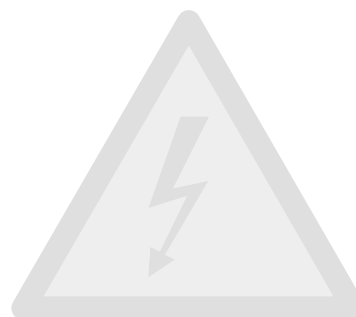

SPARK PLUG

Read carefully (MAINTENANCE).

Clean the spark plug after the first 500 km (312 mi) and thereafter every 4,000 km (2,500 mi); change it every 8,000 km (5,000 mi).

Periodically remove the spark plug and clean it carefully, removing carbon deposits; change it if necessary.

To reach the spark plug:

Remove the fuel tank (REMOVING THE FUEL TANK).

To remove and clean the spark plug:

▲ WARNING

Before carrying out the following operations, let the engine and the exhaust silencer cool down until they reach room temperature, in order to avoid burns.

Remove the spark plug cap (1). Using compressed air, blow all the dirt away from the base of the spark plug. Using the special spark plug wrench from the tool kit, unscrew the spark plug. Make sure that no dirt falls into the cylinder through the spark plug hole. Inspect the spark plug, and insure that there are no carbon deposits nor corrosion marks on either electrode or the ceramic nose that surrounds the center electrode.

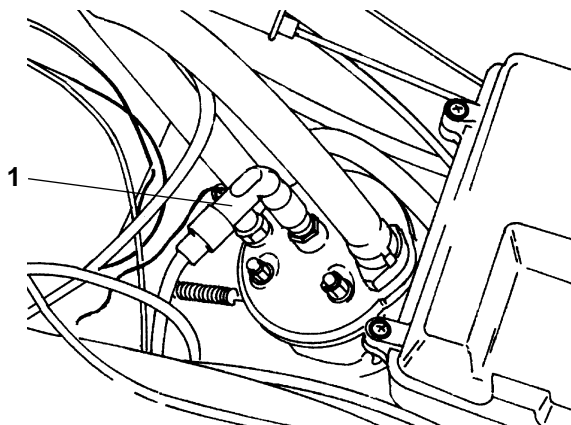

If necessary, clean the spark plug with a proprietary spark plug cleaner, and a stainless steel brush. Using compressed air, carefully blow out the spark plug after you have cleaned it.

Inspect for cracks on the insulating material, electrode corrosion or erosion, or deposits that you cannot remove. If the spark plug shows any of these defects, it must be replaced.

Check the spark plug gap with a thickness gauge. The gap must be 0.6 - 0.7 mm (0.024 - 0.028 in); if necessary adjust it, carefully bending the ground (outside) electrode.

Make sure the gasket is in good condition. With the gasket on, screw the spark plug into the head by hand.

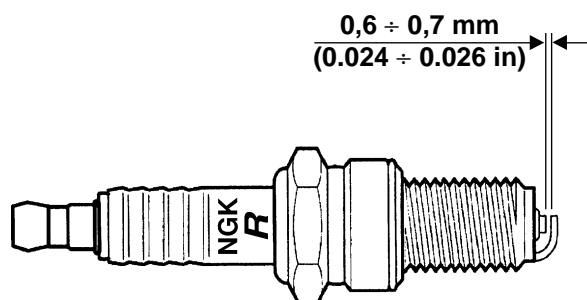

Tighten the spark plug with the spark plug wrench, approximately one-half turn after it first snugly contacts the cylinder head.

▲ CAUTION

If the spark plug is new, it should be screwed in, unscrewed again, then tightened to the specified torque.

Spark plug tightening torque:

14.8 Ft-lb (2 kgm) [20 Nm].

▲ CAUTION

The spark plug must be well tightened, otherwise the engine may overheat and be seriously damaged.

Use the recommended type of spark plug only (TECHNICAL DATA), in order not to compromise the life and performance of the engine.

Position the spark plug cap properly, so that it does not come off due to the vibrations of the engine. Replace the fuel tank.

- SPARK PLUG Standard NGK R BR9ES
- Alternative CHAMPION RN1C
- NGK R BR8ES

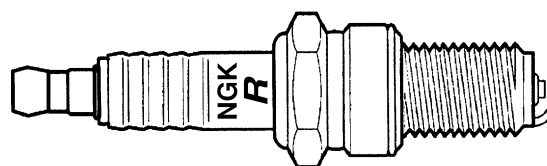

AIR CLEANER

▲ WARNING

Do not use gasoline or flammable solvents to wash the air cleaner, in order to avoid fire or explosion.

Read carefully (MAINTENANCE).

Check the condition of the air cleaner and clean it monthly or every 4,000 km (2,500 mi) depending on the conditions in which the motorcycle is used.

If the motorcycle is used on dusty or wet roads, the cleaning operations and any replacement should be carried out more frequently.

Before the cleaning operation, it is necessary to remove the air cleaner from the motorcycle.

REMOVAL

Remove the fuel tank (REMOVING THE FUEL TANK).

Unscrew and remove the screw (1).

Unscrew and remove the six screws (2).

Remove the filter case cover (3).

Remove the filter element (4).

Remove the grid (5).

▲ CAUTION

Plug the opening with a clean cloth to prevent any foreign matter from entering the air tubes.

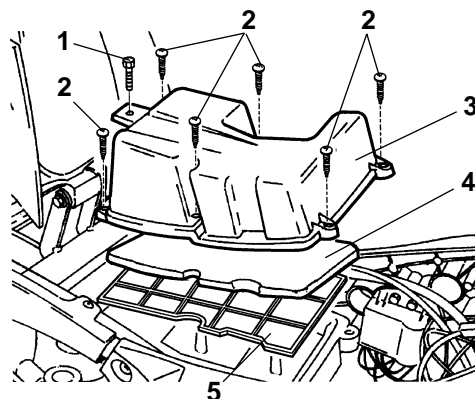

CLEANING

To clean the filter element (4), rinse it in non-flammable solvent, then allow it to dry thoroughly.

Sparingly apply filter oil, or heavy engine oil (SAE 80W-90), then squeeze the filter to eliminate any excess oil.

NOTE The filter must be completely wet with oil, but not dripping.

ADJUSTING THE THROTTLE CONTROL

Read carefully (SERVICING SCHEDULE).

▲ WARNING

If the throttle sticks open, you will lose control of your motorcycle and a serious accident could result. If any fastener in the throttle system becomes loose, likewise you will lose control of your motorcycle. Either situation can lead to an upset or collision with subsequent serious injury or death.

The play of the throttle cable must be between **2 - 3 mm (0.08 - 0.12 in)**, measured at the edge of the grip, see the illustration above. To adjust the cable:

Position the motorcycle on the stand.

Pull back the rubber boot (1).

Loosen the lock nut (2).

Rotate the adjuster (3) in such a way as to restore the prescribed value.

After the adjustment, tighten the lock nut (2) and check the play again. Replace the rubber boot (1).

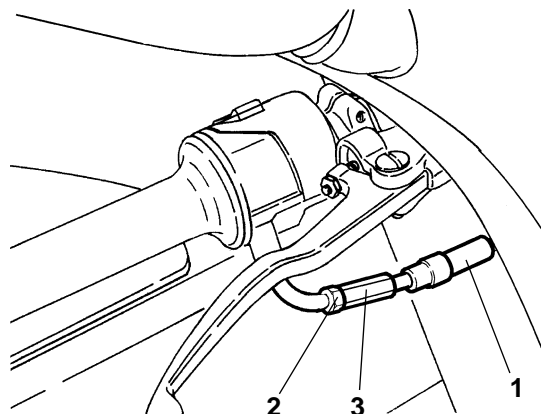

▲ WARNING

Exhaust gases contain carbon monoxide, which is extremely poisonous if inhaled. Do not start the engine in closed or badly-ventilated rooms. Failure to observe this warning may cause loss of consciousness or even lead to death by asphyxia. After you have adjusted the throttle, rotate the handlebars full left and full right with the engine idling. Check to ensure that the idle sound is not affected by this. Also check that the throttle smoothly and fully closes when released. Failure to observe this warning can lead to an accident with subsequent injury or even death.

IDLING ADJUSTMENT

Read carefully (SERVICING SCHEDULE).

If the idle becomes irregular, too fast, or too slow, it must be adjusted.

To adjust the idle:

▲ WARNING

Exhaust gases contain carbon monoxide, which is extremely poisonous if inhaled. Do not start the engine in closed or badly-ventilated rooms.

Failure to observe this warning may cause loss of consciousness or even lead to death by asphyxia.

Ride for a few miles until the engine reaches normal running temperature, (Coolant temperature indicator "H"). Put the shift lever (4) in neutral so that the green "N" light is on.

Observe the tachometer.

The engine must idle between $1,100 \pm 100$ rpm.

If it does not:

Position the motorcycle on the stand.

Remove the rubber plug (5) (right fairing).

Insert a flat-tip screwdriver in the hole and adjust the screw (6) on the carburetor.

By SCREWING IT clockwise, you increase the engine rpm.

By UNSCREWING IT counterclockwise, you decrease the engine rpm.

Twist the throttle grip, accelerating and decelerating a few times to make sure that it functions correctly and to check if the idling speed is constant.

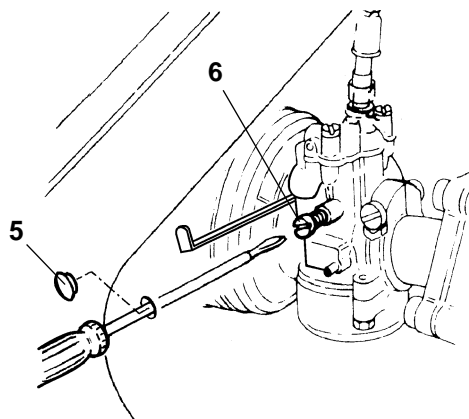
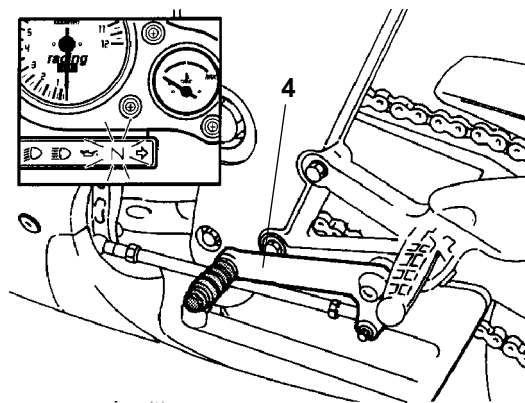

CARBURETOR CONTROLS

COLD START LEVER

The cold start lever (1) is located on the right side of the carburetor. It can be reached from above through the opening between the fairing and the frame.

To operate the cold start lever, push the lever downward.

When the engine is warmed up, before you ride away, while holding at least one brake, engage neutral (the green neutral light will illuminate). Allow the engine to warm up thoroughly.

▲ CAUTION

Do not attempt to disengage the cold start lever (1) by hand. It automatically returns to its initial proper position when the throttle grip (2) is twisted.

Do not ride away with the cold start lever (1) pushed downward. For the first few moments, do not accelerate hard. Allow the engine to thoroughly warm up before you demand full performance.

Rotating the throttle grip (2) completely counterclockwise (open), quickly, and releasing it immediately, will disengage the cold start lever.

You will hear a metallic snap which signals that the cold start lever (1) has returned to its disengaged position.

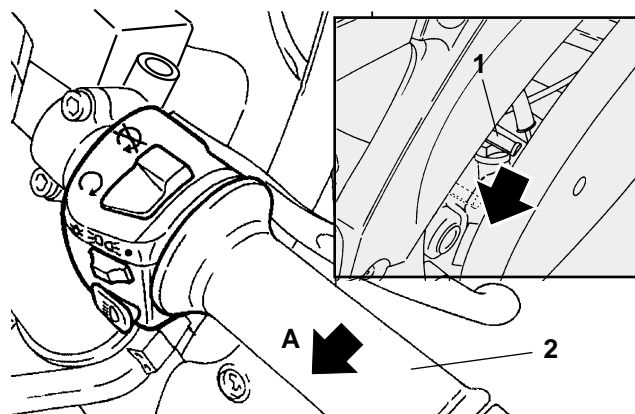

CHECKING THE GEARBOX OIL

Read carefully (GEARBOX OIL) and (SERVICING SCHEDULE).

Check the gearbox oil level every 4,000 km (2,500 miles), change the oil after the first 500 km (312 miles) and then every 8,000 km (5,000 miles), (CHANGING THE GEARBOX OIL).

CHECKING

NOTE Position the motorcycle on solid, flat ground.

Stop the engine and leave it to cool down for at least ten minutes, to allow the oil to drain down into the sump and cool down.

Remove the right-hand side fairing see (REMOVING THE SIDE FAIRINGS).

Unscrew and remove the check screw (3).

Take out the seal washer (4).

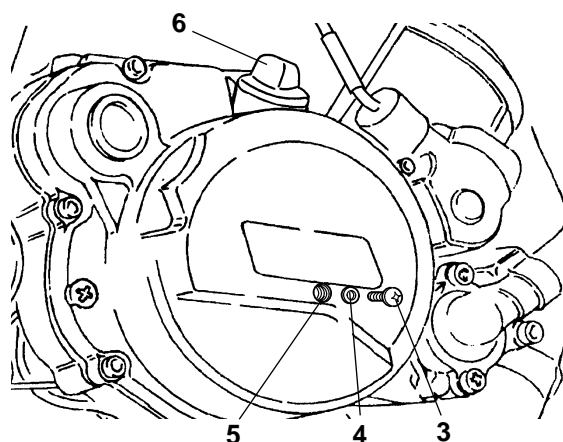

▲ CAUTION

Danger of falling or turning over.

As soon as the motorcycle is stood up, i.e. moved from the park position to the riding position, the stand retracts automatically.

Keep the motorcycle in the vertical position with both wheels on the ground.

NOTE If you attempt to check the oil with the motorcycle leaned in either direction from the vertical, your measurement will be inaccurate.

Visually check to ensure that the oil level is at or above the lower edge of the threaded hole (3).

If it is:

Inspect the gasket (2). Replace if damaged.
Install and tighten the screw (1).

If it is not:

Top up the oil per the following paragraph.

TOPPING UP

If it is necessary to top up the transmission:

Unscrew and remove the filler cap (4).

Pour a small quantity of oil and wait about one minute to allow the oil to flow into the transmission.

Check the oil level as described above.

Repeat this operation until the oil level is at or slightly above the edge of the threaded hole (3). Follow the screw installation instructions above.

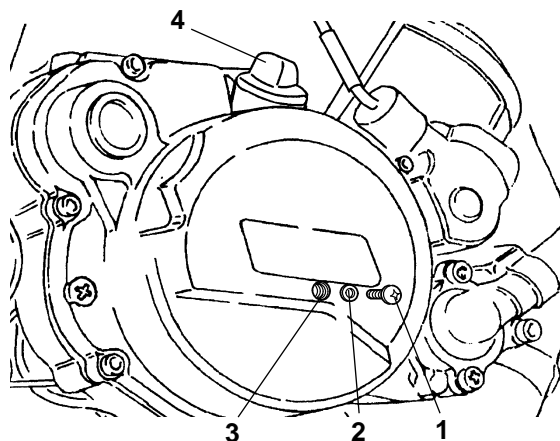
**▲ WARNING**

Tighten the filler screw snugly, to ensure that it does not leak. Regularly check the transmission cover gasket to ensure that it is not leaking.

Never ride the motorcycle with low transmission oil or with contaminated or unapproved lubricants. This will greatly accelerate the wear of moving parts, and cause irreparable failure.

It also could lead to a seizure, with subsequent crash and serious injury, or even death.

CHANGING THE GEARBOX OIL

Read carefully (GEARBOX OIL) and (SERVICING SCHEDULE).

Check the gearbox oil level every 4,000 km (2,500 miles), change the oil after the first 500 km (312 miles) and then every 8,000 km (5,000 miles).

REPLACEMENT

Start the engine (see STARTING) and keep it idling for a few minutes, to allow the oil to run out in the subsequent drainage stage.

NOTE Position the motorcycle on solid, flat ground.

Stop the engine and leave it to cool down for at least ten minutes, to allow the oil to drain down into the sump and cool down.

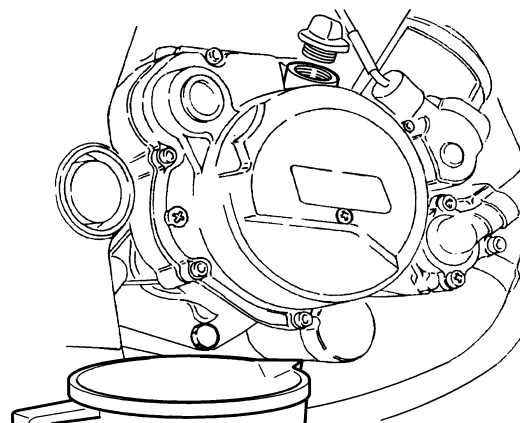

▲ CAUTION

The engine, when hot, contains oil at a high temperature: proceed with great care to avoid burns in the subsequent operations.

Remove the right-hand side fairing see (REMOVING THE SIDE FAIRINGS).

Remove the exhaust pipe, see (REMOVING THE EXHAUST PIPE).

▲ CAUTION

Danger of falling or turning over.

As soon as the motorcycle is stood up, i.e. moved from the park position to the riding position, the stand retracts automatically.

Keep the motorcycle in a vertical position with the two wheels on the ground.

Position a container (1) of capacity greater than 900 cm³ (30 US fl oz) under the drain plug (2).

Unscrew and remove the drain plug (2).

Unscrew and remove the filler plug (3).

Drain off the oil into the container (1), allowing it to drip down for a few minutes.

Remove the metal residue from the magnet on the drain plug (2).

Check the state of the drain plug washer (2), replacing it if necessary.

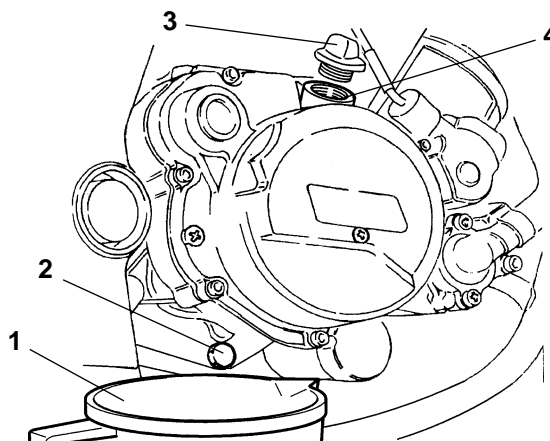

Screw in and tighten up the drain plug (2).

**Drain plug (2) torque wrench setting:
27 Nm (2.7 kgm) [19.9 Ft-lb].**

Pour about 820 cm³ (28 US fl oz) of gearbox oil into the filler hole (4), see (LUBRICANT CHART).

Screw in the filler plug (3).

Start the engine see (STARTING) and keep it idling for about one minute to allow the gearbox oil circuit to fill up.

Check the oil level, topping up if necessary see (CHECKING AND TOPPING UP THE GEARBOX OIL LEVEL).

▲ WARNING

Tighten the filler screw snugly, to ensure that it does not leak. Regularly check the transmission cover gasket to ensure that it is not leaking.

Never ride the motorcycle with low transmission oil or with contaminated or unapproved lubricants. This will greatly accelerate the wear of moving parts, and cause irreparable failure.

It also could lead to a seizure, with subsequent crash and serious injury, or even death.

2 STROKE OIL TANK

Top up the 2 stroke oil tank every 500 km (312 mi). The motorcycle is provided with a separate mixer that ensures the mixing of petrol and oil for the engine lubrication (LUBRICANT CHART). When the oil level in the 2 stroke oil tank is so low that the reserve is being used, the 2 stroke oil reserve warning light “” (1) located on the dashboard, will illuminate (INSTRUMENTS AND INDICATORS).

▲ WARNING

If the 2 stroke oil supply is exhausted, the engine will seize. This can cause an upset with consequent risk of serious injury or even death. It certainly will destroy your engine.

▲ WARNING

Do not run your engine, even for a moment, without adequate 2 stroke oil in the 2 stroke oil tank. This will cause serious damage to the engine.

If the oil in the 2 stroke oil tank ever runs dry, or if the 2 stroke oil tube is removed, then the circuit must be bled.

This operation must be carried out before further running, since running the engine with air in the 2 stroke oil system will result in serious damage to the engine, an engine seizure, a possible accident, with subsequent serious injury or death.

To fill the 2 stroke oil tank:
Remove the rider saddle, see (REMOVING THE RIDER SADDLE). Remove the filler cap (1). Using a funnel, fill the tank to the appropriate level with 2 stroke oil.

TANK CAPACITY: 1.6 / (1.69 qt)

Replace the filler cap (1), ensuring that it is properly sealed. Replace the rider saddle.

▲ WARNING

Wash your hands thoroughly after handling the oil. Do not dispose of the oil in drains, water courses or the soil.

KEEP OUT OF REACH OF CHILDREN.

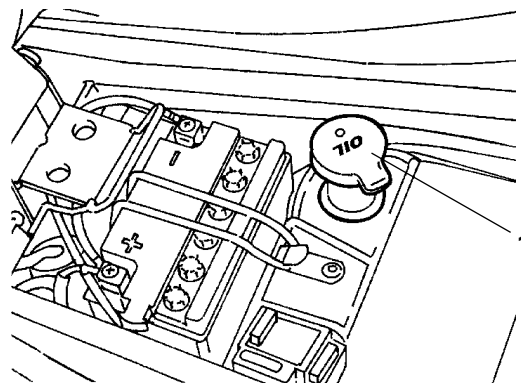

REMOVING THE OIL FROM THE 2 STROKE OIL TANK

Read carefully (PRECAUTIONS AND GENERAL INFORMATION).

Remove the rider and passenger saddle (REMOVING THE RIDER AND PASSENGER SADDLE).

Remove the right-hand side fairing (REMOVING THE SIDE FAIRINGS).

Keep the motorcycle in the vertical position with the rear stand OPT.

Remove the two screws (1) shown in the figure and take off the oil pump cover.

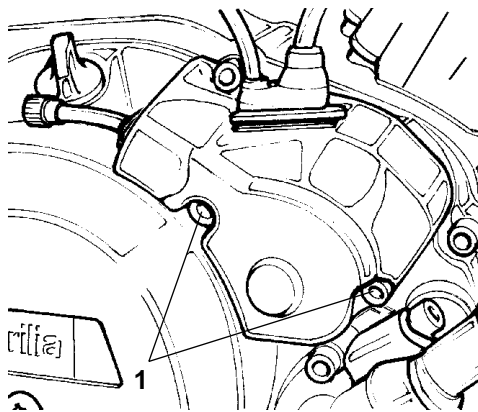

Get a container of capacity greater than 2 / (1.1 gal).

Remove the clamp (2) then detach the oil inlet tube (3), allowing all the oil to flow out of the tank into the container.

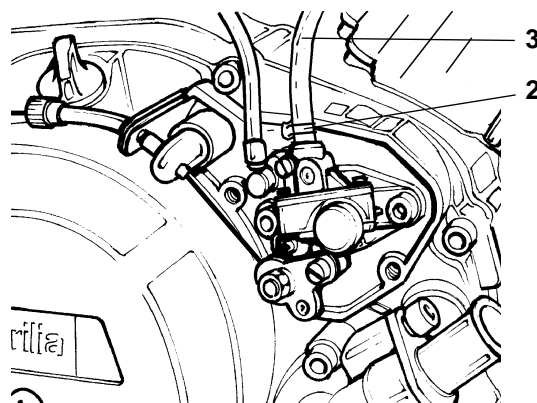

After emptying the tank, reconnect the oil inlet tube (3) and secure it with the clamp (2). Refit the oil pump cover and screw it on with the screws (1).

Torque setting for screws (1):
4 Nm (0.4 Kgm) [2.9 Ft-lb].

▲ WARNING

Wash your hands thoroughly after handling the oil. Do not dispose of the oil in drains, water courses or the soil.

KEEP OUT OF REACH OF CHILDREN.

COOLANT

▲ CAUTION

Do not use the motorcycle if the coolant is below the minimum prescribed level.

Check the coolant level every 2,000 km(1,250 mi) and after long trips; change it every 24 months.

▲ WARNING

Coolant is poisonous! Do not ingest coolant under any circumstance.

Should you get coolant in your mouth, rinse with cool water and immediately seek medical attention. Coolant is also very dangerous to your skin and eyes. Should you accidentally get coolant on your clothing or skin, change clothes immediately. Wash coolant from your skin with hot water and soap. Should you get coolant in your eyes, flush with plenty of cool water and seek professional medical help at once. Should someone swallow coolant accidentally, induce vomiting, rinse mouth with water, and immediately seek professional medical attention.

2**DISPOSE OF THE COOLANT PROPERLY.**

BE SURE TO KEEP THE DRAINED COOLANT AWAY FROM CHILDREN AND PETS. IT IS SWEET TASTING, AS WELL AS EXTREMELY POISONOUS, AND IS VERY ATTRACTIVE TO CHILDREN AND PETS.

Use extra caution not to spill the coolant on any hot parts of the engine. It is flammable, and can emit invisible, noxious fumes.

Always wear rubber or latex gloves when servicing the cooling system.

The coolant is composed of 50% distilled water and 50% nitrite-free antifreeze. This mixture is optimum for all temperatures down to -35°C .

This mixture of antifreeze and distilled water should be used year-round, winter and summer, since evaporative losses are thus minimized and excellent corrosion protection is provided.

▲ CAUTION

Never use tap water in the cooling system. Use only distilled water. This will minimize the deposition of minerals in the radiator, as coolant evaporates, and minimize also the reduction in the efficiency of the cooling system, which occurs when hard, mineral laden water is used.

If your motorcycle is used at temperatures below freezing, check the coolant often. If it is used at temperatures below -35°C , increase the proportion of antifreeze in the coolant as instructed by the antifreeze manufacturer, up to a maximum of 60% (40% water).

▲ WARNING

Never remove the cap (1) when the engine is even warm, since the coolant is under high pressure and is very hot. If it splashes out and contacts your skin or clothing, it will cause severe burns.

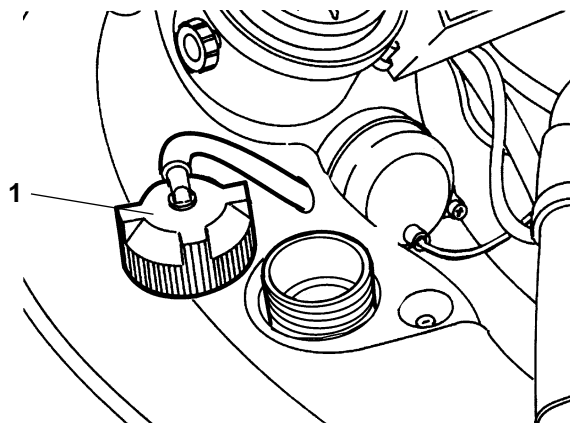

CHECKING AND TOPPING UP

▲ WARNING

Never remove the cap (1) when the engine is even warm, since the coolant is under high pressure and is very hot. If it splashes out and contacts your skin or clothing, it will cause severe burns.

Stop the engine and wait until it has cooled down.

NOTE Position the motorcycle on firm and flat ground.

▲ WARNING

The side stand retracts automatically when the motorcycle is picked up from its leaned over position on the side stand. Be careful not to let the bike fall over when you lift the bike up to perform this check.

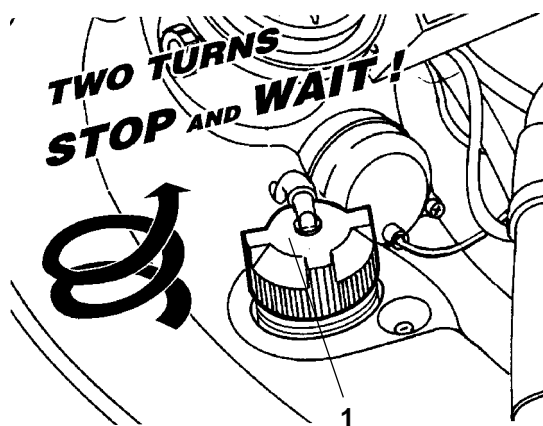

Keep the motorcycle in a vertical position, with the two wheels resting on the ground.

Loosen the filler cap (1) (by giving it two counterclockwise turns), without removing it.

Wait a few seconds in order to release any residual pressure that may be present in the circuit.

NOTE The cap is equipped with a breather tube (2). Do not disconnect the breather tube (2).

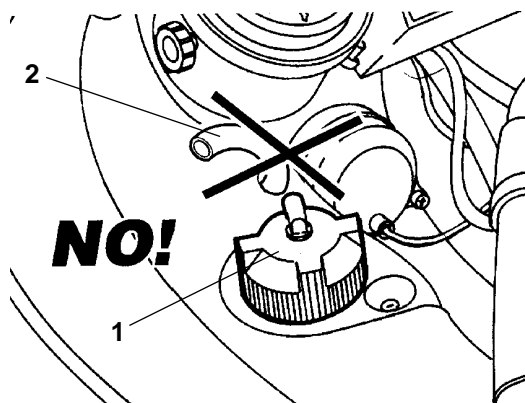

Unscrew and remove the filler cap (1).

▲ WARNING

Coolant is poisonous! Do not ingest coolant under any circumstance. Should you get coolant in your mouth, rinse with cool water and immediately seek medical attention. Coolant is also very dangerous to your skin and eyes. Should you accidentally get coolant on your clothing or skin, change clothes immediately. Wash coolant from your skin with hot water and soap. Should you get coolant in your eyes, flush with plenty of cool water and seek professional medical help at once. Should someone swallow coolant accidentally, induce vomiting, rinse mouth with water, and immediately seek professional medical attention. Do not use your fingers or any other object to check if there is enough coolant.

The coolant filler (1) neck has a smaller diameter ring (3) that indicates the proper coolant level. Visually check the coolant level against this ring.

If it is not:

Top up with coolant, see (LUBRICANT CHART) until the coolant level reaches the ring (3). Do not exceed this level, otherwise the coolant will flow out while the engine is running.

Replace the filler cap (1).

▲ CAUTION

If there is excessive coolant consumption or if the expansion tank empties, check that there are no leaks in the circuit.

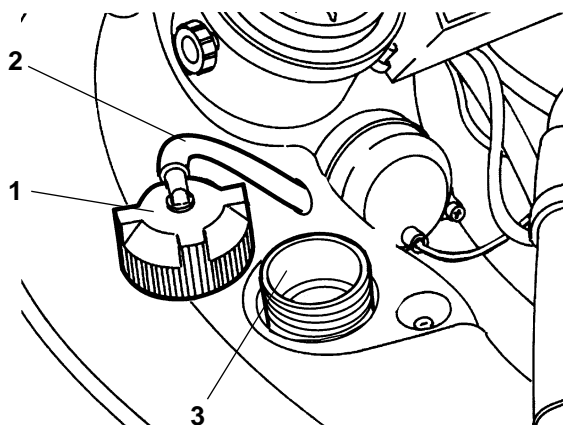

CHANGING THE COOLANT

Read carefully (**PRECAUTIONS AND GENERAL INFORMATION**) and (**COOLANT**).

Change the coolant every two years.

Remove the right-hand side fairing (**REMOVING THE SIDE FAIRINGS**).

Place a container under the drain plug (1) to collect the fluid (capacity greater than 1 / / 0.26 gal).

Unscrew and remove the drain plug (1) and take off the copper washer.

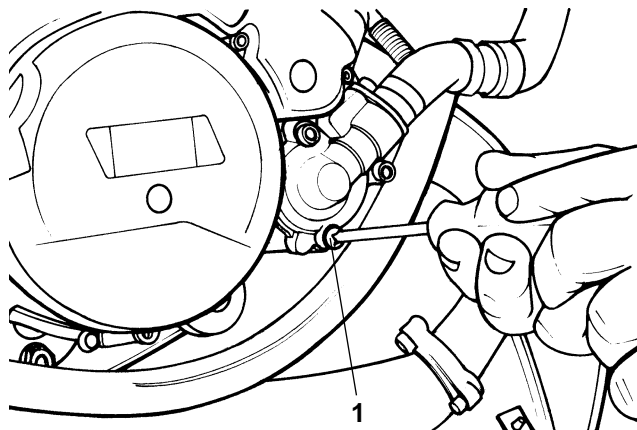
**▲ WARNING**

Do not remove the filler cap (2) when the engine is hot, as the coolant is under pressure and at a high temperature.

Remove the filler cap (2) to allow the fluid to flow out more quickly (2).

Wait until the coolant has all drained out.

DO NOT DISPOSE OF THE FLUID IN DRAINS, WATER COURSES OR THE SOIL.

Replace the drain plug (1), using a new copper washer.

Drain plug (1) torque setting:

6 Nm (0.6 Kgm) [4.4 Ft-lb].

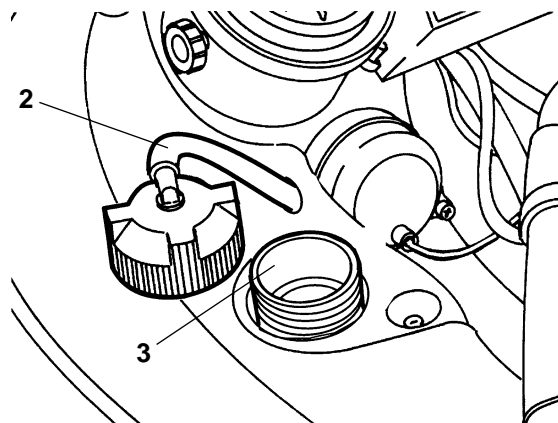

Fill the filler hole (3) right to the brim.

Squeeze and release the hoses (4) several times by hand to create a slight pressure to allow the fluid to flow into the tubing.

Top up again.

NOTE The fluid is at the right level when it settles just below the brim of the filler hole (3).

Screw on the filler cap (2).

Start the engine and run it for a few minutes, allow it to cool down and then recheck-the fluid level.

Top up if necessary (**CHECKING AND TOPPING UP**).

Total quantity: 0.9 / (0.24 gal)

NOTE There is no need to bleed the air from the system on this motorcycle.

For further information see COOLING SYSTEM.

CHECKING AND TOPPING UP THE BRAKE FLUID

NOTE This motorcycle is equipped with front and rear disc brakes with separate hydraulic systems.
The following information may refer to just one braking system but should be observed with regard to both brakes.

⚠ WARNING

Sudden variations in the play or looseness of the brake lever are caused by problems in the hydraulic circuits.

Make sure the brake discs are not worn or greasy, especially after servicing or checking the brakes.

Make sure that the brake lines are not twisted, kinked or damaged in any way.

Take care not to allow water or dust to get into the circuit accidentally.

You are advised to wear rubber gloves when servicing the hydraulic circuit.

Brake fluid can cause irritation if it comes into contact with the skin or eyes.

Thoroughly wash any parts of the body that come into contact with the fluid and contact an eye specialist or doctor if the fluid comes into contact with the eyes.

DO NOT DISPOSE OF BRAKE FLUID IN THE ENVIRONMENT. KEEP BRAKE FLUID AWAY FROM CHILDREN.

KEEP OUT OF REACH OF CHILDREN.

⚠ CAUTION

Avoid splashing brake fluid on the plastic or painted parts of the motorcycle, as it will cause damage.

⚠ CAUTION

The brakes are the most important guarantee of safety on the motorcycle, and must be kept in a perfect state of efficiency at all times.

Change the brake fluid once a year.

Use the type of brake fluid specified in the lubricant charts see (LUBRICANT CHART).



▲ CAUTION

This motorcycle has front and rear hydraulic disc brakes.

As the friction pads wear down, the fluid level decreases to compensate automatically for the wear.

The front brake fluid reservoir is situated on the right handlebar, next to the front brake lever attachment.

The rear brake fluid reservoir is situated under the upper fairing on the right-hand side of the motorcycle.

2**FRONT BRAKE****CHECKING THE SYSTEM**

NOTE Carry out these checks only on a firm, flat surface such as a concrete garage floor.

Place the motorcycle on the stand.

Rotate the handlebars fully counterclockwise so that the top surface of the brake fluid in the front brake reservoir is parallel to the top edge of the reservoir (1).

Ensure that the fluid level is up to the top of the glass gauge (2). If not, top off.

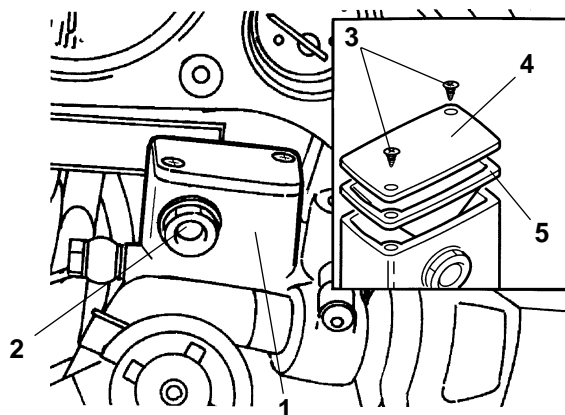
**TOPPING UP****▲ WARNING**

Danger of brake fluid spilling out. Do not pull the brake lever when the screws (3) are slackened or, above all, when the top of the brake fluid reservoir is off.

Unscrew the two screws (3).

Remove the top (4).

NOTE Keep the fluid in the reservoir parallel to the top edge of the reservoir; this will stop the dangerous fluid from spilling out when topping up.

▲ CAUTION

Do not expose the brake fluid to the air for long periods.

Brake fluid is hygroscopic and absorbs moisture on contact with the air.

Leave the brake fluid reservoir open ONLY the minimum time necessary for topping up.

Remove the gasket (5).

▲ WARNING

Do not go over the "MAX" level when topping up. Fill to the "MAX" level only when new pads are fitted.

The fluid level decreases gradually as the pads wear down.

Do not fill to the "MAX" level with worn pads, as the fluid will spill out when the brake pads are replaced with new ones.

NOTE The peep-hole (2) can be used as a reference for filling to the "MAX" level: with the top edge of the brake fluid reservoir parallel to the ground, fill until the peep-hole (2) is completely covered by the fluid.

Fill the reservoir with brake fluid see (LUBRICANT CHART) until the peep-hole is completely covered. Replace the gasket (5) in its seating. Replace the top (4). Screw in and tighten up the two screws (3).

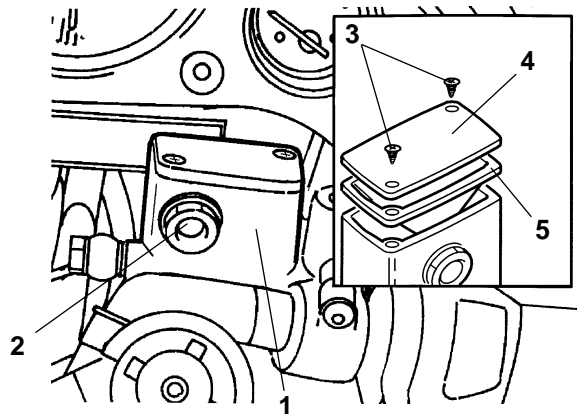
**▲ WARNING**

Check the efficiency of the brakes.

If the brake lever has too much play or is too loose, or if there are air bubbles in the circuit, then the air may need to be bled out of the system.

REAR BRAKE

CHECKING THE SYSTEM

NOTE Carry out these checks only on a firm, flat surface such as a concrete garage floor.

▲ WARNING

The side stand retracts automatically when the motorcycle is picked up from its leaned over position on the stand.

Be careful not to let the bike fall over when you lift the bike up to perform this check.

Maintain the motorcycle in a vertical position so that the surface of the fluid in the rear brake reservoir (1) is parallel to the top (2) edge of the reservoir.

Check that the fluid in the reservoir is above the "MIN" mark.

If the fluid doesn't reach the "MIN" mark, top up.

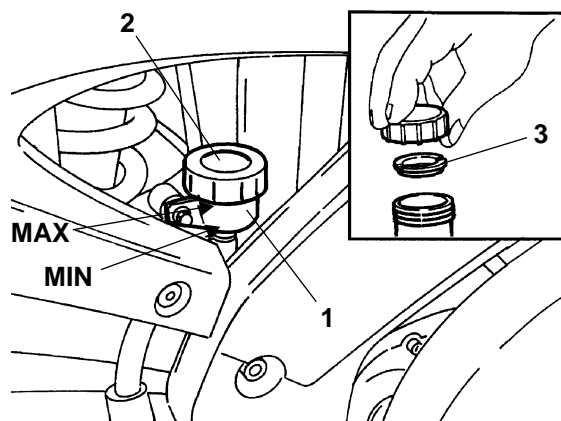

2

TOPPING UP

▲ WARNING

Danger of brake fluid spilling out. Do not work the rear brake lever when the fluid reservoir cap is loosened or removed.

Unscrew and remove the cap (5).

▲ CAUTION

Do not expose the brake fluid to the air for long periods.

Brake fluid is hygroscopic and absorbs moisture on contact with the air.

Leave the brake fluid reservoir open ONLY the minimum time necessary for topping up.

NOTE Keep the brake fluid parallel to the top edge of the reservoir (horizontal position) when topping up, to stop it spilling out.

Remove the gasket (6).

Using an oil syringe, fill the reservoir (4) with brake fluid, see (LUBRICANT CHART) to the correct level, i.e. between the "MIN" and "MAX" reference marks.

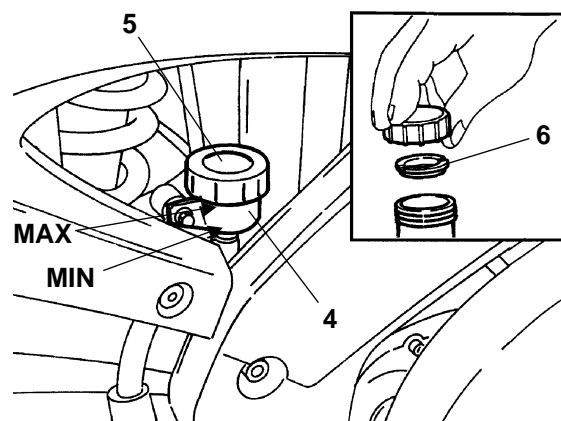

▲ WARNING

Fill to the "MAX" level only when new pads are fitted.

The fluid level decreases gradually as the pads wear down.

Do not fill to the "MAX" level with worn pads, as the fluid will spill out when the brake pads are replaced with new ones.

To refit the components, follow the removal procedure in reverse order.

▲ CAUTION

Check the efficiency of the brakes.

If the brake lever has too much play or is too loose, or if there are air bubbles in the circuit, then the air may need to be bled out of the system.

CHANGING THE FRONT BRAKE FLUID

Read carefully (PRECAUTIONS AND GENERAL INFORMATION) and (BRAKE FLUID).

Change the front brake fluid every year.

▲ WARNING

Handle the fluid with care: it reacts chemically with the paintwork, plastic parts, rubber parts, etc.

DO NOT DISPOSE OF BRAKE FLUID IN THE ENVIRONMENT.



Remove the protective rubber cap.

Fit one end of a transparent plastic tube over the brake caliper bleed valve (1) and insert the other end in a container to collect the fluid.

Slacken the bleed valve (1) about one turn.

NOTE Check that there is fluid in the reservoir throughout the entire operation, otherwise the air will have to be bled out of the circuit after changing the fluid (BLEEDING THE BRAKE CIRCUITS).

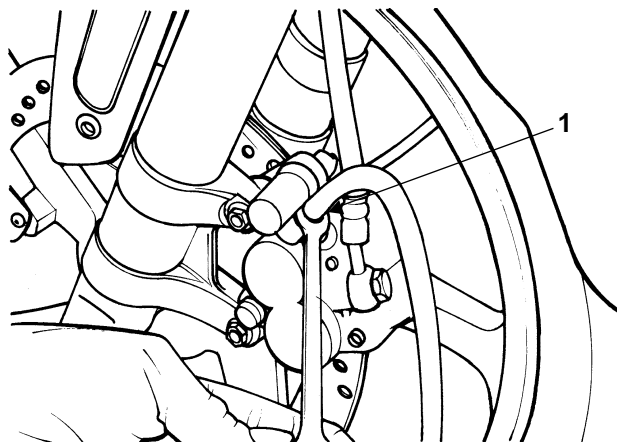

Keep checking the fluid as it flows out of the reservoir (2), and tighten up the bleed valve (1) before the reservoir empties.

Top up the reservoir (2) see (CHECKING AND TOPPING UP THE BRAKE FLUID).

Slacken the bleed valve (1) again, about half a turn. Check the fluid as it flows down the tube, and when the color of the fluid changes (from darker to lighter) tighten up the bleed valve (1) and remove the tube.

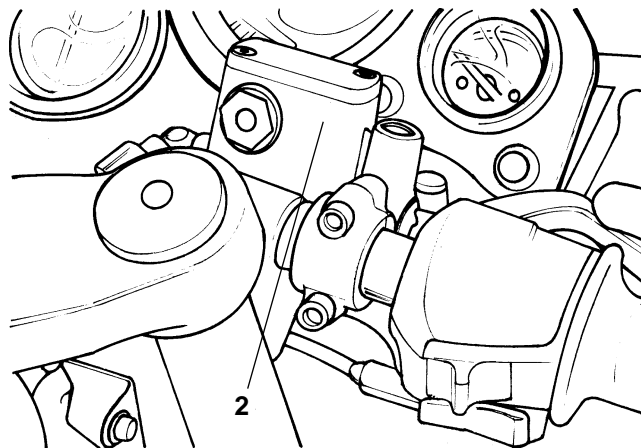

2

Refit the protective rubber cap.

Top up the fluid to the correct level in the reservoir (2) see (CHECKING AND TOPPING UP THE BRAKE FLUID).

CHANGING THE REAR BRAKE FLUID

Read carefully (PRECAUTIONS AND GENERAL INFORMATION) and (BRAKE FLUID).

Change the rear brake fluid every year.

▲ WARNING

Handle the fluid with care: it reacts chemically with the paintwork, plastic parts, rubber parts, etc.

DO NOT DISPOSE OF BRAKE FLUID IN THE ENVIRONMENT.



Remove the protective rubber cap.

Fit one end of a transparent plastic tube over the brake caliper bleed valve (1) and insert the other end in a container to collect the fluid.

Slacken the bleed valve (1) about one turn.

NOTE Check that there is fluid in the reservoir throughout the entire operation, otherwise the air will have to be bled out of the circuit after changing the fluid (BLEEDING THE BRAKE CIRCUITS).

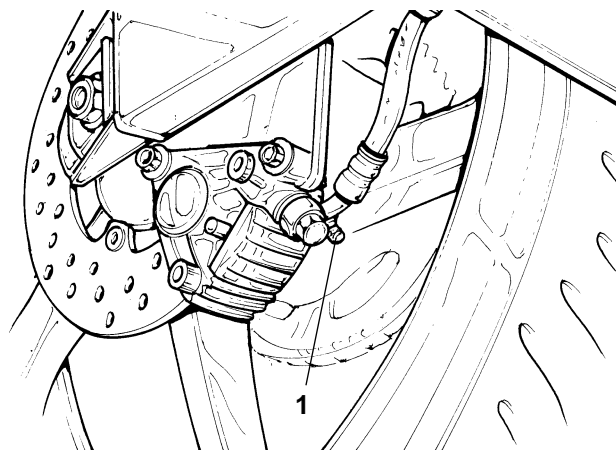

Keep checking the fluid as it flows out of the reservoir (2), and tighten up the bleed valve (1) before the reservoir empties.

Top up the reservoir (2) see (CHECKING AND TOPPING UP THE BRAKE FLUID).

Slacken the bleed valve (1) again, about half a turn. Check the fluid as it flows down the tube, and when the color of the fluid changes (from darker to lighter) tighten up the bleed valve (1) and remove the tube.

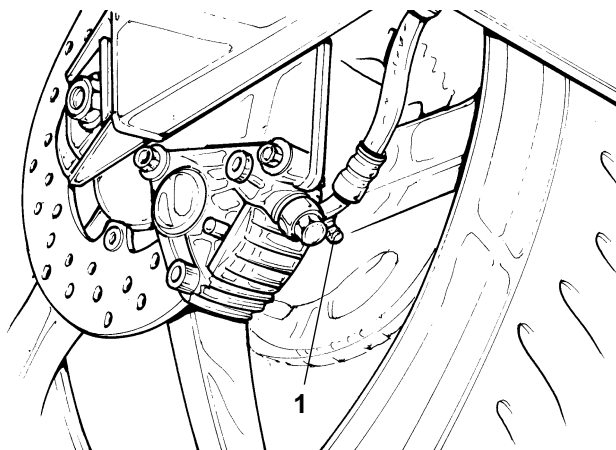

Refit the protective rubber cap.

Top up the fluid to the correct level in the reservoir (2) see (CHECKING AND TOPPING UP THE BRAKE FLUID).

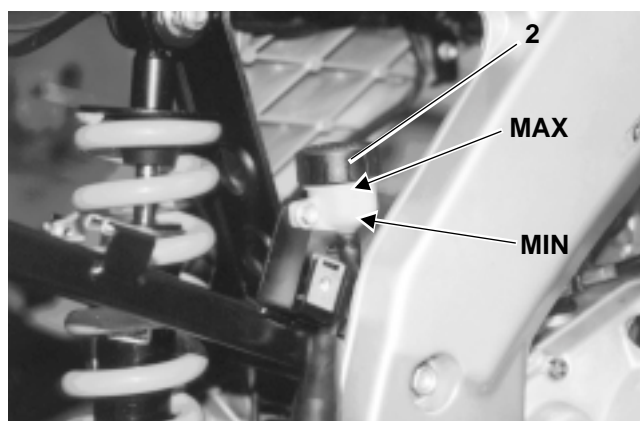

BLEEDING THE BRAKE CIRCUITS

Read carefully (PRECAUTIONS AND GENERAL INFORMATION) and (BRAKE FLUID).

Bleed the air from the system after the first 500 km (312 miles).

If there is any air in the hydraulic system it acts as a cushion, absorbing most of the pressure exerted on the brake master cylinder and reducing the effectiveness of the brake calipers when braking.

Air in the system also give a "spongy" feel to the brake lever and reduces the braking capacity.

▲ WARNING

Handle the fluid with care: it reacts chemically with the paintwork, plastic parts, rubber parts, etc.

DO NOT DISPOSE OF BRAKE FLUID IN THE ENVIRONMENT.

▲ CAUTION

Given the potential danger to the motorcycle and rider, it is absolutely essential to bleed the air from the hydraulic circuit after refitting the brakes and setting up the system for normal use conditions.

To do this, proceed as follows:

Top up the reservoir with brake fluid see (CHECKING AND TOPPING UP THE BRAKE FLUID).

2

Remove the protective rubber cap.

Fit one end of a transparent plastic tube over the brake caliper bleed valve (1) and insert the other end in a container to collect the fluid.

Pull and release the brake lever several times, then keep it fully engaged.

Slacken the bleed valve 1/4 of a turn so that the brake fluid runs into the container; this will take the tension off the brake lever so that it pulls fully to its travel limit.

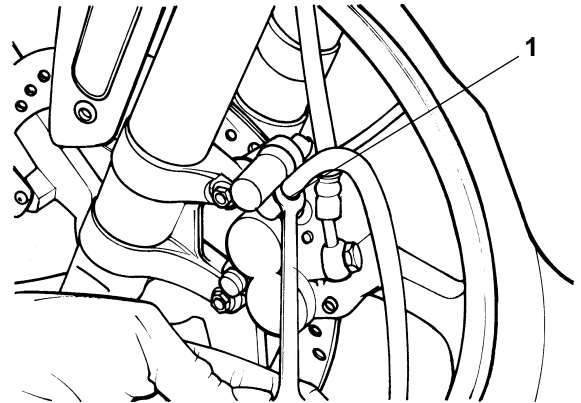

Tighten up the bleed valve (1), pump the brake lever a few times, then keep it fully engaged and unscrew the bleed screw again.

Keep repeating this operation until the fluid running into the container is completely free of air bubbles.

NOTE Top up the reservoir with brake fluid whenever necessary when bleeding the hydraulic system. Keep checking to ensure that there is brake fluid in the reservoir throughout the entire operation.

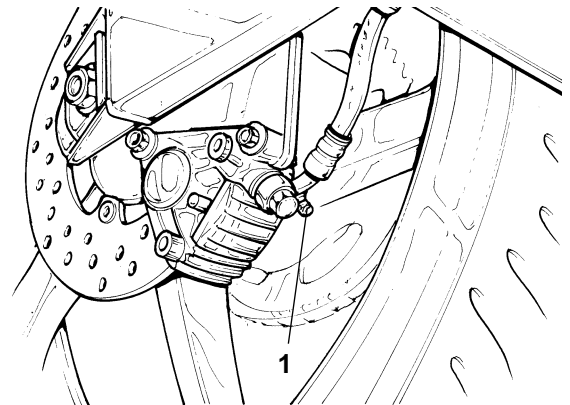

Tighten up the bleed valve and disconnect the tube.

Top up the reservoir to the correct level with brake fluid see (CHECKING AND TOPPING UP THE BRAKE FLUID).

Refit the protective rubber cap.

ADJUSTING THE REAR BRAKE

The brake pedal is adjusted to fit most riders during manufacture.

If you wish to adjust the brake pedal:

Position the motorcycle on the stand.

Loosen the lock nut (1).

Unscrew the brake adjuster bolt (2) completely.

Loosen the lock nut (3) on the master cylinder push rod (4) and run it as far towards the master cylinder as far as it will go on the threads of the push rod.

Screw the push rod (4) completely into the clevis, then unscrew it three to four turns.

Adjust the brake adjuster bolt (2) until the brake pedal (5) is positioned as you like it.

Screw down and tighten the lock nut (1) on the brake adjuster bolt (2).

Screw the master cylinder push rod (4) out of the clevis until it just contacts the master cylinder piston.

Then, screw the push rod into the clevis to obtain a minimum clearance of 0.5 - 1 mm (0.02 - 0.04 in) between the master cylinder push rod (4) and the master cylinder piston.

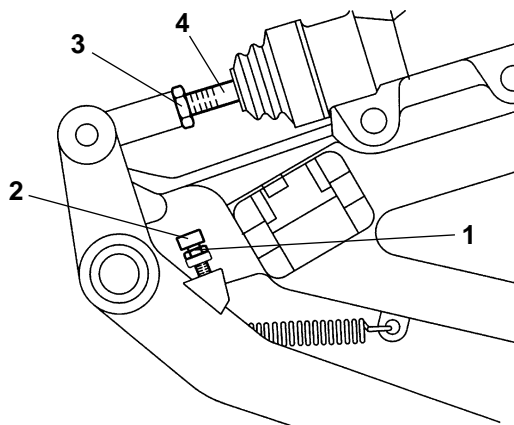

▲ CAUTION

Be sure there is the specified clearance between the master cylinder push rod and the master cylinder piston. If this caution is not observed, the brake will remain slightly applied, with subsequent brake overheating and wear of pads and discs.

Clearance between the push rod and the piston:
0.5 - 1 mm (0.02 - 0.04 in).

Lock the push rod in position with the lock nut (3).

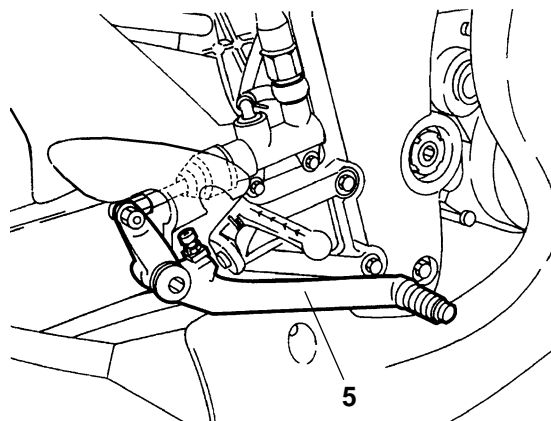

▲ WARNING

After making any brake adjustment apply the brakes repeatedly. Try the brakes in a parking lot or other area where there is little traffic. After you have completed the adjustment, lift the wheel free of the ground and ensure that it rotates freely when the brake is released.

ADJUSTING THE CLUTCH

The clutch needs adjusting when the engine cuts out, or when the motorcycle tends to move forward when it is in gear with the clutch lever engaged, or when the clutch "slips", causing a lag in the acceleration in relation to the engine speed.

A limited range of adjustment of the clutch can be accomplished using the adjuster (1) located at the left handlebar:

Position the motorcycle on the stand.

Pull back the rubber boot (2).

Loosen the lock nut (3).

Turn the adjuster (1) until the play at the end of the clutch lever reaches the distance A ($A = 10$ to 15 mm / 0.4 to 0.6 in).

Tighten (screw in) the nut (3) to lock the adjuster (1).

Recheck the free play.

Reposition the rubber boot (2).

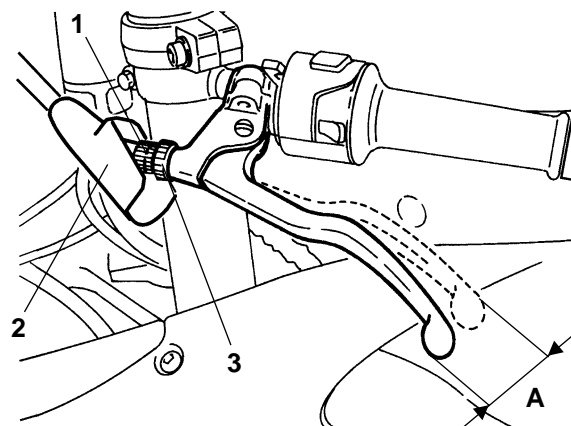

NOTE Inspect the clutch cable to make sure that it is not damaged. The inner cable must have no broken strands, and the outer cable must not be kinked or bent.

Lubricate the clutch cable at periodic intervals with a suitable lubricant see (LUBRICANT CHART), to prevent premature wear and corrosion.

ADJUSTING THE SHIFT LEVER

The shift lever may be adjusted by adjusting the length of the rod (4) as follows:

Position the motorcycle on the stand.

Loosen the nuts (5, 6).

Rotate the rod to adjust the shift lever position.

Tighten the nuts (5, 6).

Lubricate the shift lever pivot see (LUBRICANT CHART).

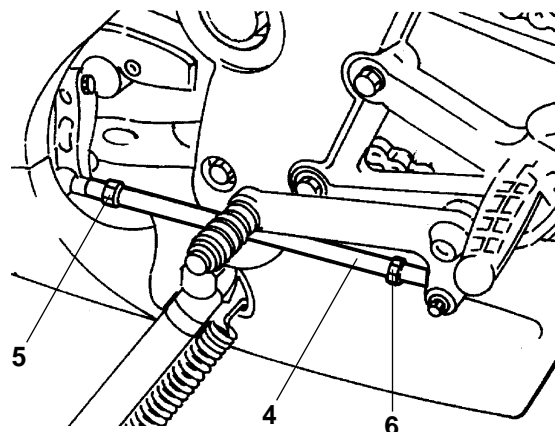

STEERING

Read carefully (PRECAUTIONS AND GENERAL INFORMATION).

To improve the handling, the steering has been fitted with antifriction bearings.

The steering must be set correctly to ensure that the handlebar turns smoothly and steers the bike safely. If the steering is too tight, the handlebar will not turn smoothly, and if it is too loose it will make the motorcycle more unstable.

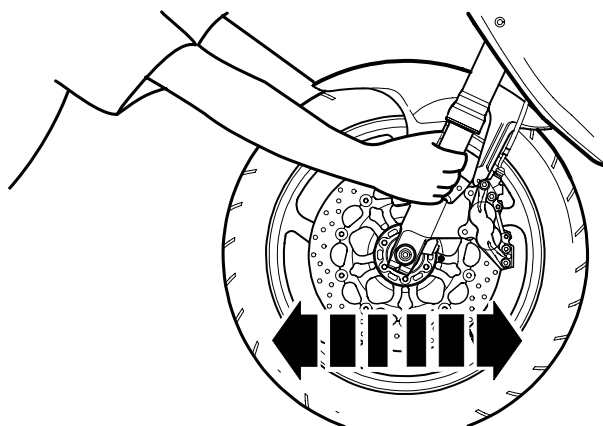

CHECKING THE PLAY IN THE BEARINGS

Position the motorcycle on the rear stand **OPT** see (POSITIONING THE MOTORCYCLE ON THE REAR SUPPORT STAND **OPT**).

Shake the fork back and forward in the direction of travel.

If you can feel play in the fork, then it needs to be adjusted.

CHECKING THE PLAY ON THE BEARINGS

Read carefully (PRECAUTIONS AND GENERAL INFORMATION).

Unscrew and remove the steering sleeve cap (1) and its washer (2).

Unscrew the two screws (3) that secure the plate on the top of the fork legs.

Unscrew and remove the fork caps (4).

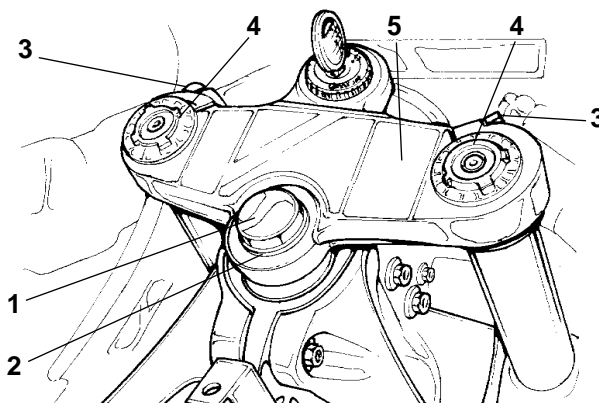

Keep the front wheel straight when removing the plate from the top of the fork.

Withdraw the plate (5) from its seat on top of the fork and tighten the ring nut (6).

Tightening of ring nut (6):
tighten fully by hand + 1/4 of a turn.

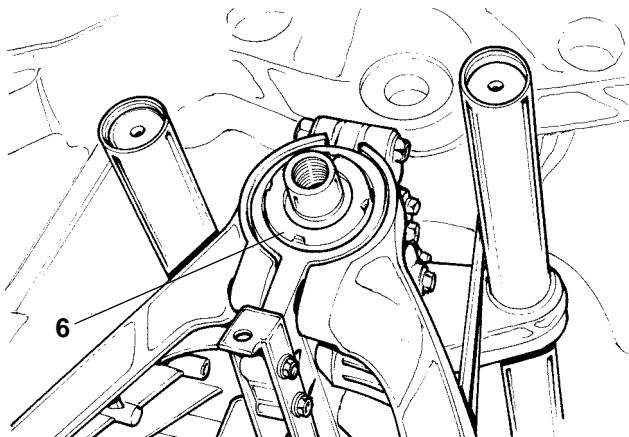

Reposition the top plate (5), fitting it in correctly.
Position the washer (2) on the sleeve then screw in and tighten up the sleeve cap (1).

Torque setting for sleeve cap (1):
80 Nm (8.0 kgm) [59 Ft-lb].

Screw in and tighten up the screws (3).

Torque setting for screws (3):
24 Nm (2.4 kgm) [17.7 Ft-lb].

Screw in and tighten up the fork caps (4).

Torque setting for fork caps (4):
5 Nm (0.5 kgm) [3.7 Ft-lb].

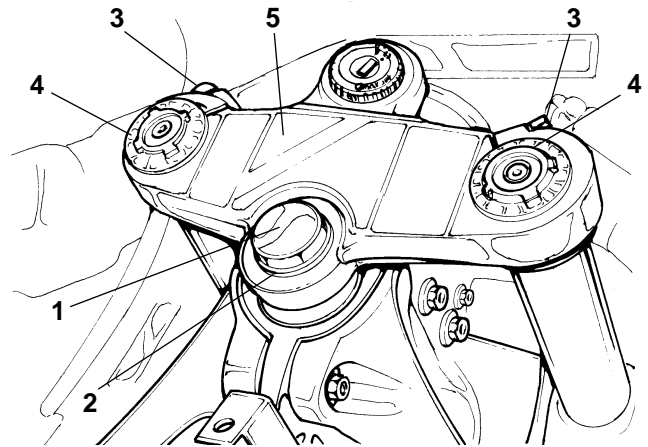

2

▲ WARNING

When finished, make sure that the handlebar turns smoothly; if it doesn't, there is a risk of damaging the raceways and affecting the maneuverability of the motorcycle.

DRIVE CHAIN

Read carefully (SERVICING SCHEDULE).

This motorcycle is equipped with a chain and master link.

When the master link is installed, the clip (6) must be installed with the closed end in the direction of travel as shown above.

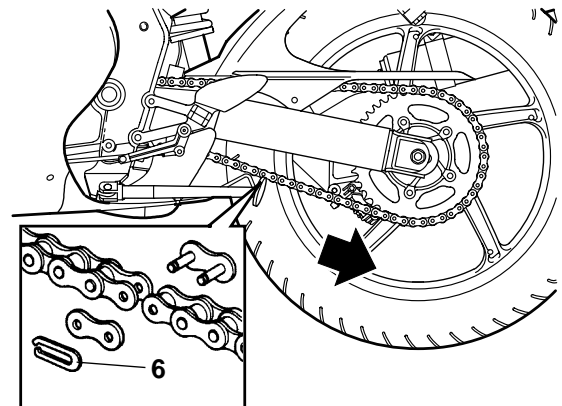

▲ WARNING

An excessively loose chain can come off the sprocket which can result in a serious accident and serious damage to the motorcycle from the upset and subsequent serious injury or even death.

Do not ride your motorcycle with an improperly adjusted chain (ADJUSTMENT).

▲ WARNING

To inspect the condition of the chain, grasp the chain where it goes around the sprocket and try to pull it away from the sprocket. If you can move it more than one-eighth of an inch away from the sprocket, the chain is worn out and the chain and both front and rear sprockets must be replaced.

CHECKING THE PLAY

To check the play:

Stop the engine.

Position the motorcycle on the stand.

Shift to neutral.

Check the chain play. It should be **25 mm (0.98 in)** at mid-bottom span as shown above.

Move the motorcycle forward or backward, or support the rear wheel in the air and turn the wheel to several positions, to check the chain slack at several locations. If the slack is markedly different with the wheel in different positions, the chain and sprockets must be replaced.

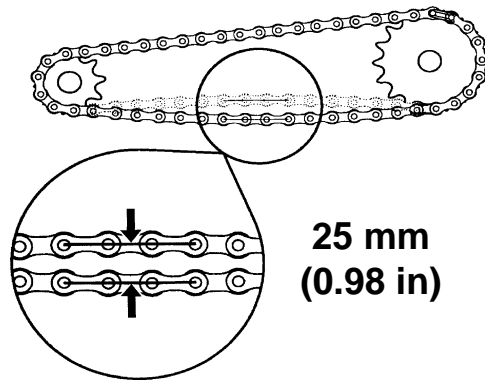
**▲ WARNING**

Do not ever operate your motorcycle with a damaged chain. This could cause wheel seizure which could lead to an upset with subsequent serious injury or death. Lubricate your chain frequently to minimize the possibility of this kind of damage (CLEANING AND LUBRICATION).

If the play is the same at several locations, but is more or less than **25 mm (0.98 in)**, adjust it, see (ADJUSTMENT).

ADJUSTMENT

NOTE To adjust the chain it is necessary to use the appropriate rear support stand **OPT.**

To adjust the chain tension:
Position the motorcycle on the appropriate rear support stand **OPT.**, see (POSITIONING THE MOTORCYCLE ON THE REAR SUPPORT STAND **OPT.**).
Loosen the nut (1) to several turns.

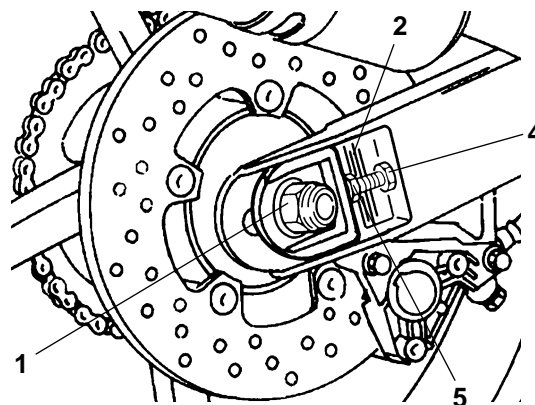
**2**

NOTE In order to make wheel centering in the swinging arm easier, there are reference marks (2-3) on the swing arm. See illustration above.

Loosen the two lock nuts (4).
Adjust the tension adjusters (5) to obtain the appropriate chain play, ensuring that the edge of tension adjuster is in the same position with regard to the reference marks (2-3) on each side of your motorcycle.
Tighten the two lock nuts (4).
Tighten the nut (1).

Wheel nut tightening torque:
73.8 Ft-lb (10 kgm) [100 Nm].

Check the chain play again, see (CHECKING THE PLAY).

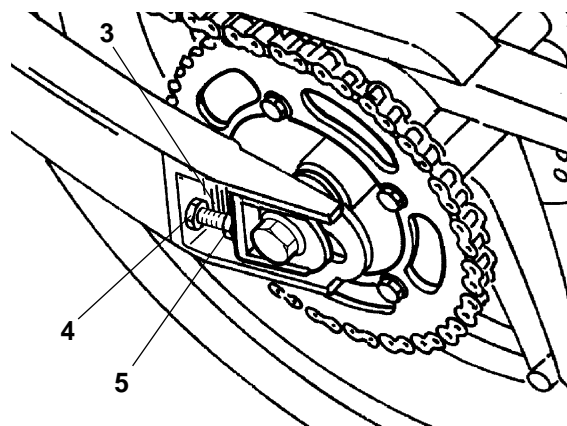
**CHECKING THE WEAR OF THE CHAIN AND SPROCKETS**

In addition to the check inspect the chain and sprockets to make sure that there are no:

- Damaged rollers.
- Loose pins.
- Dry, rusty, crushed or seized links.
- Excessive wear.
- Sprocket or teeth excessively worn or damaged.

▲ CAUTION

If chain rollers are damaged and pins are loose, both sprockets as well as the chain must be replaced.

▲ CAUTION

Lubricate the chain frequently, especially if it displays any rust or if it is dry to the touch. If, after lubricating the chain, it still has links which cannot be turned easily, the chain must be replaced.

Finally, check the wear of the rear fork protection shoe.

▲ WARNING

Keep your fingers well clear of the chain and sprocket, especially if you are turning the rear wheel while working on the motorcycle. You can easily be seriously injured if a finger is caught between the chain and sprocket.

CLEANING AND LUBRICATION

▲ CAUTION

Carry out the adjustment, lubrication, cleaning and change of the chain with great care.

Lubricate the chain every 500 km (312 mi) or whenever it appears dry.

Use a proprietary chain lubricant or SAE 80W- 90 oil.

Never wash your motorcycle, and especially never wash the chain, with high pressure water, coin operated car laundry wand, steam cleaner, or inflammable solvent.

ROUTINE MAINTENANCE AND SERVICING OPERATIONS

Read carefully (PRECAUTIONS AND GENERAL INFORMATION).

Check the state of the tread after the first 1,000 km (625 miles) and then every 4,000 km (2,500 miles) or 8 months.

Check the inflation pressure every month at ambient temperature.

This motorcycle is equipped with tubeless tires.

TREAD STATE

▲ WARNING

Check the tire inflation before you ride your motorcycle, at least once a week, (see TECHNICAL DATA). Pressure measurement must always be carried out when the tires are cold, as when the tires are warmed up, pressure will increase, and if they are checked at this time erroneous readings will be seen.

If the tire is inflated to too high a pressure, an uncomfortably harsh ride will result, and riding comfort will be compromised. Also, road holding, especially during turns and in wet conditions, will likewise be compromised.

If the tire is underinflated (pressure is too low), the tire may slip on the rim with consequent loss of control. Again, road holding and handling characteristics will be degraded, and brake performance will be reduced.

When the tire is worn to a point where any tread is less than 3 mm (0.12 in) deep, the tire is worn out, and must be replaced. Also, if a tire suffers a puncture that is larger than 5 mm (0.20 in) in its longest dimension, the tire must not be repaired, but should be replaced.

After a tire is repaired, balance the wheels. Use only tires that are listed, (see TECHNICAL DATA). Insure that all tires are equipped with properly installed valve caps.

TREAD MINIMUM THICKNESS LIMIT (A):

front and rear 1,5 mm (USA 3 mm)
0.0059 in (USA 0.12 in)

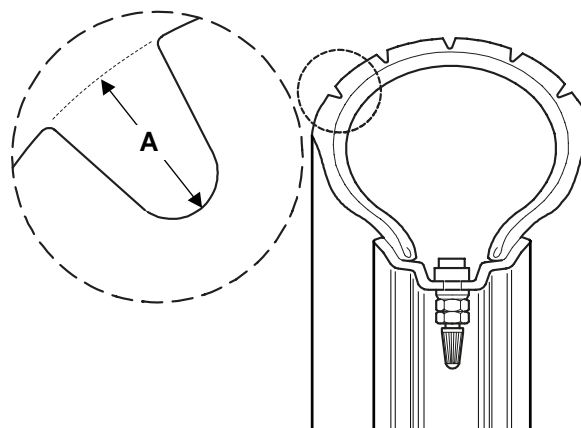
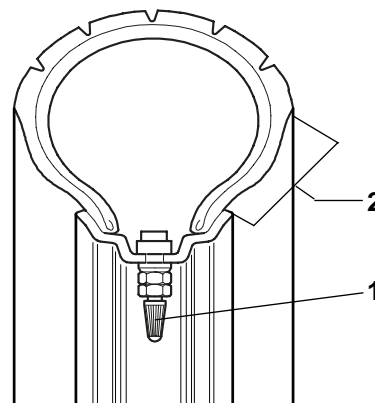

▲ WARNING

Do not use the motorcycle if the tire wear indicators signal that a change is necessary.

Some types of tires approved for this motorcycle are provided with wear indicators. There are several kinds of wear indicators.

For more information on how to check the wear, contact your Dealer.

Visually check if the tires are worn and in this case have them changed. If a tire goes flat while you are riding your motorcycle, do not attempt to continue. Avoid abrupt braking and steering. Slowly move over to the shoulder and stop, using engine compression to slow you down.

▲ WARNING

Failure to obey these instructions can lead to an upset with consequent serious injury or even death.

If your tires are older than five years, even if they are not completely worn out, they have probably become hard and brittle, and may not allow for good road holding. If the tires are noticeably hard, or develop checks or cracks, have them replaced.

Use only tires of the size listed in the TECHNICAL DATA. Do not install an oversized or undersized tire. Likewise, do not install tube-type tires on rims intended for tubeless tires, and vice-versa.

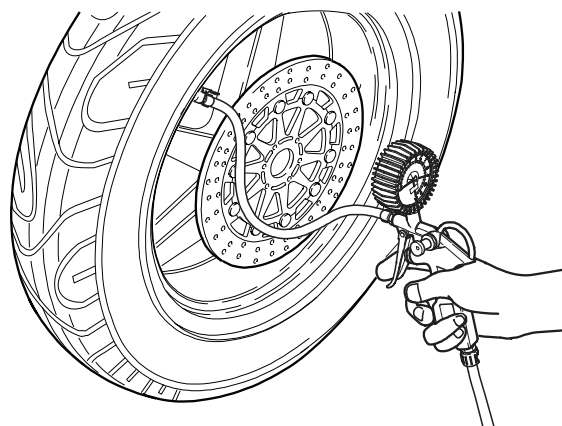

Inflation pressure

FRONT: 90/80 17" 46S
 90/80 17" 46P

Inflation pressure
 rider only 170 kPa (1.7 bar) [24.6
 Psi]

Inflation pressure
 rider plus passenger (*) 180±10 kPa (1.8±0.1 bar)
 [26±1.4 Psi]

REAR: 110/80 17" 57S
 110/80 17" 57P

Inflation pressure
 rider only 190 kPa (1.9 bar) [27.5
 Psi]

Inflation pressure
 rider plus passenger (*) 210±10 kPa (2.1±0.1 bar)
 [30.4±1.4 Psi]

(*) = in countries where passengers are to be carried

▲ WARNING

Repair, maintenance, changing and balancing of tires are very important to your safety, and should only be performed by qualified mechanics using the appropriate tools.

▲ WARNING

New tires are often covered with a slippery mold release compound. Scrub the tires in by riding slowly and making numerous turns for the first few miles.

Do not use any kind of tire dressing or other liquid on your tires. Especially do not permit any petroleum products, such as oil, gasoline or brake fluid to come in contact with the tires. If you do, wipe it immediately, then scrub the tire with soap and water and a stiff brush. Do not use a tire that is worn out.

Minimum tread depth is measured as shown above. The minimum tread depth (A) for both the front and the rear tires is 3 mm (0.12 in).

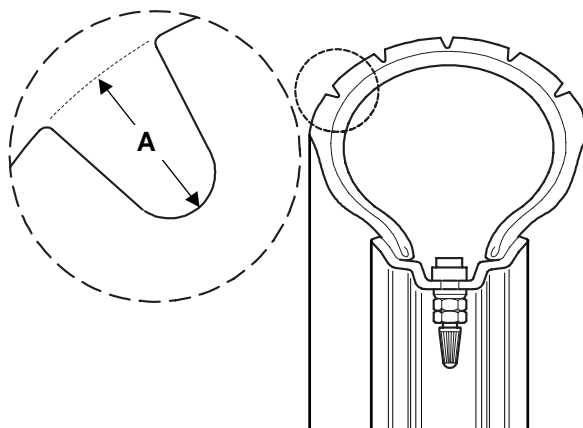
**FUEL LINES****Read carefully (FUEL).**

Check the state of the fuel lines every 4,000 km (2,500 miles) or 8 months. Renew them every 4 years.

Change the fuel lines if there are any signs of wear, scraping etc.

For further information, see (FUEL FEED SYSTEM).

BRAKE PIPES/HOSES**Read carefully (BRAKE FLUID).**

Check the state of the pipes/hoses every 4,000 km (2,500 miles) or 8 months; renew them every 4 years.

Change the pipes/hoses if there are any signs of wear, scraping, etc.

COOLING SYSTEM HOSES**Read carefully (COOLANT).**

Check the state of the cooling system hoses (1) every 4,000 km (2,500 miles) or 8 months.

Change the cooling system hoses if there are any signs of wear, scraping, etc.

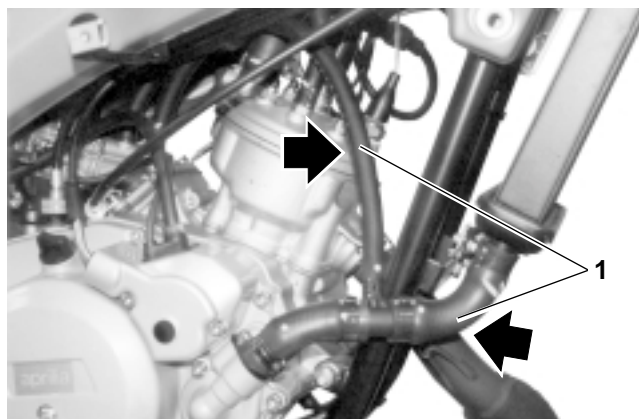

2 STROKE OIL PIPES/HOSES

Check the state of the 2 stroke oil pipes/hoses (2) every 4,000 km (2,500 miles) or 8 months.
Renew them every 4 years.

Change the 2 stroke oil pipes/hoses if there are any signs of wear, scraping, etc.

TIGHTENING NUTS AND BOLTS

Read carefully (PRECAUTIONS AND GENERAL INFORMATION).

Check after the first 1,500 km (936 miles) and then every 7,500 km (4,687 miles) or 8 months.

Make a thorough check of all the fasteners, especially on the essential safety components, i.e.:

handlebars;
front brake control lever;
clutch control lever;
fuel delivery tube;
front fork and plates;
fork pinch screws / front wheel spindle;
front wheel;
front brake hose connections;
front brake discs;
front brake calipers;
engine;
sprocket;
rear brake control lever;
swing arm;
swing arm lever mechanism;
rear suspension;
rear wheel;
rear brake disc;
rear brake caliper;
rear brake hose connections.

▲ WARNING

The fasteners must be tightened to the specified torque wrench settings, using LOCTITE ® where specified, see (FASTENERS).



FASTENERS

Check, tightening when necessary, after the first 1,000 km (625 miles) and then every 7,500 km (4,687 miles) or 8 months.

▲ WARNING

The fasteners listed in the table below must be tightened to the specified torque settings, using a torque wrench and, where indicated, LOCTITE®.

Fasteners marked () are particularly important for safety.

FRAME					
Description	Qty.	Screw/nut	Nm (Ft-lb)	Kgm	Code
Pillar to frame	2	hex fl. M8x25	24 (17.7)	2.4	8152287
Pillar to frame	2	hex fl. M10x35	47 (34.7)	4.7	8152318
Cradle to upper frame	2	hex fl. M8x35	24 (17.7)	2.4	8152289
Cradle to lower frame	2	hex fl. M8x35	24 (17.7)	2.4	8152289
Fairing bracket	2	hex fl. M6x16	10 (7.4)	1	8152278
Arch to frame	2	hex fl. M6x30	15 (11.1)	1.5	8152281
Wire guide to cradle	1	hex fl. M6x16	10 (7.4)	1	8152278
Radiator to cradle	1	hex fl. M6x12	7 (5.2)	0.7	8152277
Air box to pillar	1	hex fl. M6x16	5 (3.7)	0.5	8152278
Exhaust pipe support to pillar, rh side	2	hex fl.M8x20	24 (17.7)	2.4	8152286

FOOTREST					
Description	Qty.	Screw/nut	Nm (Ft-lb)	Kgm	Code
Plate to rh-lh pillar support	2	Allen screw M6x16	10 (7.4)	1	8150137
Footrest support to lower cross member	2	hex fl. M8x30	25 (18.4)	2.5	8152288
Footrest support to upper frame	2	hex fl. M8x30	25 (18.4)	2.5	8152288

STAND					
Description	Qty.	Screw/nut	Nm (Ft-lb)	Kgm	Code
Stand to frame	1	Dwg.11767	2.5 (1.8)	2.5	8152310

SWING ARM					
Description	Qty.	Screw/nut	Nm (Ft-lb)	Kgm	Code
Adjustment bush setting	1	Dwg.102876	3 (2.2)	0.3	8221278
Rear mudguard/guard to swing arm	3	socket screw M5x12	3 (2.2)	0.3	8152302
Swing arm pin	1	Dwg.102875	70 (51.6)	7	8225332

FRONT SUSPENSION					
Description	Qty.	Screw/nut	Nm (Ft-lb)	Kgm	Code
Sleeve nut	1	Nut M20x1,5	80 (59)	8	8203579
Caps to fork legs	2	Allen screw M5x16	5 (3.7)	0.5	8150280
Upper plate side screws	2	Allen screw M8	24 (17.7)	2.4	on plate
Stiffener plate to fork	4	hex fl.M6x16	10 (7.4)	1	8152278
Steering lock	1	Allen screw M8x16	24 (17.7)	2.4	8150211
Steering lock	1	Pull screw			8150349

REAR SUSPENSION

Description	Qty.	Screw/nut	Nm (Ft-lb)	Kgm	Code
Shock absorber to swing arm	1	Allen screw M10x60	48 (35.4)	4.8	8150049
Shock absorber to pillar	1	Allen screw M10x60	48 (35.4)	4.8	8150049

ENGINE

Description	Qty.	Screw/nut	Nm (Ft-lb)	Kgm	Code
Shift lever pin	1	Dwg.5058	12 (8.8)	1.2	8121284
Joint to brake lever	1	Nut M6	5 (3.7)	0.5	8152299
Joint to transmission	1	Nut M6	5 (3.7)	0.5	8152299
Engine to frame	3	Allen screw M8x100	24 (17.7)	2.4	8150388
Starter lever	1		1 (0.7)	0.1	Screw on carburetor
Carburetor screw	1		2 (1.5)	0.2	Screw on carburetor
Neutral cable to engine switch	1		1 (0.7)	0.1	Screw on engine
Shift lever connecting rods	1	hex. M6x20	10 (7.4)	1	8152279
Air box hose to carburetor	1	Clamp	3 (2.2)	0.3	8102401
Sprocket guard	1	socket screw M5x16	4 (2.9)	0.4	8152298

AIR BOX

Description	Qty.	Screw/nut	Nm (Ft-lb)	Kgm	Code
Air box support pin	2	Dwg.103316	10 (7.4)	1	8221270

EXHAUST SYSTEM

Description	Qty.	Screw/nut	Nm (Ft-lb)	Kgm	Code
Silent-block to cross member	1	Nut M8	25 (18.4)	2.5	8152300
Exhaust pipe to silent-block	1	Allen screw m8x12	12 (8.8)	1.2	8152112
Muffler to support	1	Allen screw m8x12	12 (8.8)	1.2	8152112

COOLING SYSTEM

Description	Qty.	Screw/nut	Nm (Ft-lb)	Kgm	Code
Water filler to dashboard closing cowl	1	socket screw M5x16	4 (2.9)	0.4	8152298

FRONT WHEEL

Description	Qty.	Screw/nut	Nm (Ft-lb)	Kgm	Code
Front wheel spindle	1	Nut M12x1.25	80 (59)	8	8225195
Leg to wheel spindle	1	Allen screw M6	8 (5.9)	0.8	Screw on fork

REAR WHEEL

Description	Qty.	Screw/nut	Nm (Ft-lb)	Kgm	Code
Rear wheel spindle	1	Nut	80 (59)	8	8225208

FRONT BRAKE

Description	Qty.	Screw/nut	Nm (Ft-lb)	Kgm	Code
Front brake caliper	2	hex. fl. M8x30	22 (16.2)	2.2	8152288
Front brake master cylinder assy.	2		12 (8.8)	1.2	Already on pump
Stop switch to front brake lever	2	Allen screw 2.2x12.7	0.5 (0.4)	0.05	8150238

REAR BRAKE

Description	Qty.	Screw/nut	Nm (Ft-lb)	Kgm	Code
Rear brake lever pin	1	Dwg.5058	12 (8.8)	1.2	8121149
Rear brake master cylinder	2	hex fl. M6x20	10 (7.4)	1	8152279
Brake lever adjuster	1	hex fl. M5x16	5 (3.7)	0.5	8152273
Rear brake caliper	2	hex fl. M8x20	22 (16.2)	2.2	8152286
Brake fluid reservoir	1	hex fl. M6x16	3 (2.2)	0.3	8152278

HANDLEBAR CONTROLS

Description	Qty.	Screw/nut	Nm (Ft-lb)	Kgm	Code
Clutch control	1		12 (8.8)	1.2	Already on control
Lh main/dipped beam switch	2		2 (1.5)	0.2	Already on switch
Throttle control	2	Cover screws	2 (1.5)	0.2	Already on carburetor
Rh main/dipped beam switch	2		2 (1.5)	0.2	Already on switch

ELECTRICAL COMPONENTS

Description	Qty.	Screw/nut	Nm (Ft-lb)	Kgm	Code
Voltage regulator to cradle	1	hex fl. M6x35	7 (5.2)	0.7	8152282
Transducer to frame	2	hex fl. M6x16	7 (5.2)	0.7	8152278
Thermistor	1		17 (12.5)	1.7	8222019
Tail light to support	2	Allen screw 4.2x25	2 (1.5)	0.2	8150423
Horn	1	hex fl. M6x12	12 (8.8)	1.2	8152277
Tail light to central fairing	3	Allen screw 4.2x20	2 (1.5)	0.2	8150270

TANKS

Description	Qty.	Screw/nut	Nm (Ft-lb)	Kgm	Code
2 stroke oil tank	4	socket screw M6x16	6 (4.4)	0.6	8152246
Petrol cock	2	socket screw M6x12	4 (2.9)	0.4	8152186
Aluminum filler to tank	6	socket screw M6x12	4 (2.9)	0.4	8152186
Tank cover to pillar (rear part)	1	hex fl. M6x70	7 (5.2)	0.7	8150314
Tank cover to petrol tank	2	socket screw M6x15	3 (2.2)	0.3	8152108
Ring nut to tank cover	5	Allen screw M4x10	3 (2.2)	0.3	8152043

DASHBOARD

Description	Qty.	Screw/nut	Nm (Ft-lb)	Kgm	Code
Dashboard to arch	3	Nut M6	10 (7.4)	1	8150430

SADDLES

Description	Qty.	Screw/nut	Nm (Ft-lb)	Kgm	Code
Passenger saddle strap	2	hex fl. M6x20	5 (3.7)	0.5	8152279
Passenger saddle strap	2	Nut M6	5 (3.7)	0.5	8150333
Passenger saddle to rear fairing	7	swp 3.9x10	2 (1.5)	0.2	8150444
Passenger saddle to rear fairing	2	Nut M5	2 (1.5)	0.2	8152306
Passenger saddle strap	2	Nut M6	5 (3.7)	0.5	8152299
Saddle closing lever	1	Allen screw M6x8	5 (3.7)	0.5	8152213

BODY					
Description	Qty.	Screw/nut	Nm (Ft-lb)	Kgm	Code
Reflector to front mudguard	4	Nut M4	3 (2.2)	0.3	8150204
Front mudguard to stiffener plate	4	hex fl. M6x16	7 (5.2)	0.7	8152278
Front mudguard to fork	2	socket screw M5x12	5 (3.7)	0.5	8152302
Rear fairing lower closing cowl to pillar	2	socket screw M6x16	5 (3.7)	0.5	8152246
Rear fairing lower closing cowl to pillar	1	socket screw M5x9	5 (3.7)	0.5	8152339
Rear reflector to license plate holder	2	Nut M4	3 (2.2)	0.3	8150204
Headlight support to license plate holder	2	Allen screw 4.8x13	3 (2.2)	0.3	8150246
Rear fairing lower closing cowl to license plate holder	3	socket screw M6x16	5 (3.7)	0.5	8152246
Dashboard closing cowl to arch	1	socket screw M5x12	4 (2.9)	0.4	8152302
Front fairing to arch	4	socket screw M6x16	5 (3.7)	0.5	8152246
Pillar cover to rear fairing (rh-lh)	4	socket screw M5x12	3 (2.2)	0.3	8152302
Complete rear fairing to pillar cover	2	socket screw M5x20	3 (2.2)	0.3	8152269
Complete rear fairing to pillar cover	2	socket screw M5x12	3 (2.2)	0.3	8152302
Fairings to frame	4	socket screw M5x12	3 (2.2)	0.3	8152302
Fairing to saddle cowl and fairing interior	8	socket screw M5x12	3 (2.2)	0.3	8152302
Lh fairing extension to fairing	2	socket screw M5x12	3 (2.2)	0.3	8152302
Fairing interior to fairing	4	Allen screw 3.9x14	1 (0.7)	0.1	8150413
Fairing interior to fairing	4	Allen screw 3.9x7.5	1 (0.7)	0.1	8150420

CHAIN					
Description	Qty.	Screw/nut	Nm (Ft-lb)	Kgm	Code
Chain adjustment screw	2	Nut M8 low	1.5 (0.8)	1.5	8152305
Chain guide to swing arm	1	Allen screw 4.8x13	3 (2.2)	0.3	8150246

Steel / aluminum screws with similar modulus

SCREW	Nm (Ft-lb)	kgm
M4	3 (2.2)	0.3
M5	6 (4.4)	0.6
M6	12 (8.8)	1.2
M8	25 (18.4)	2.5
M10	50 (36.9)	5.0
M12	80 (59)	8.0



NOTES

Engine

3

ENGINE COMPONENTS THAT CAN BE REMOVED WITHOUT REMOVING THE ENGINE FROM THE FRAME

Read carefully (PRECAUTIONS AND GENERAL INFORMATION).

The parts listed below can be removed and refitted without removing the engine from the frame.

▲ WARNING

The procedures in this chapter are described in a series of ordered steps.

The overlapping of operations in references to other chapters must be interpreted in a logical way, to avoid the unnecessary removal of components.

Carry out only the operations necessary for the removal of the component in question.



TOP

- Carburetor (1)
- Reed valve set (2)
- Spark plug (3)
- Thermostat (4)
- Thermistor (5)

FRONT

- Exhaust pipe
- Cylinder head (6)
- Cylinder (7)

RIGHT SIDE

- Water pump (8)
- Oil pump
- Clutch cover
- Clutch

LEFT SIDE

- Sprocket (9)
- Flywheel side cover (10)
- Flywheel
- Stator
- Pick-up
- Starter motor (11)

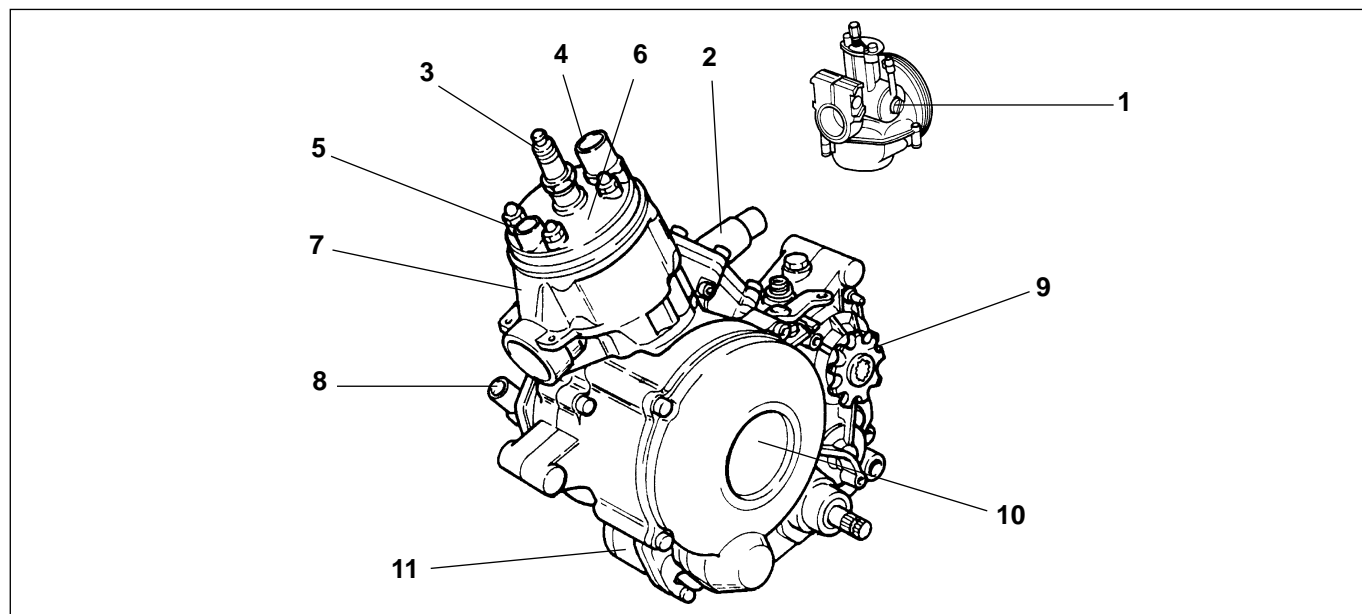

NOTE For instructions on the removal of the parts, refer to WORKSHOP MANUAL

- N° 966 X (I)
- N° 967 X (F)
- N° 968 X (D)
- N° 969 X (E)
- N° 970 X (UK)
- N° 971 X (USA)

REMOVING THE COMPLETE ENGINE FROM THE FRAME

Read carefully (PRECAUTIONS AND GENERAL INFORMATION).

▲ WARNING

Removing the engine is a particularly complex task. Study the motorcycle carefully before proceeding.

3

The procedures in this chapter are described in a series of ordered steps.

The overlapping of operations in references to other chapters must be interpreted in a logical way, to avoid the unnecessary removal of components.

Carry out only the operations necessary for the removal of the component in question.

Before proceeding with the operations described below, remember that the engine has to be removed from the frame in a downward direction; make sure you have the necessary equipment correctly positioned.

Switch the ignition key to the "⊗" position.

Position the motorcycle on the rear stand **OPT** (POSITIONING THE MOTORCYCLE ON THE REAR STAND).

Remove the rider saddle (REMOVING THE RIDER AND PASSENGER SADDLE).

Disconnect the battery leads: first the negative (-) and then the positive (+).

▲ WARNING

When refitting the battery, connect the positive lead (+) first, and then the negative lead (-).

Removing the tank (REMOVING THE FUEL TANK).

Remove the side fairings (REMOVING THE SIDE FAIRINGS).

Remove the saddle cowl (REMOVING THE SADDLE COWL).

Completely drain the cooling system (CHANGING THE COOLANT).

Remove the carburetor (REMOVING THE CARBURETOR).

Remove the complete exhaust pipe (REMOVING THE EXHAUST PIPE).

Unscrew the ring nut (1) and remove the tachometer cable (2).

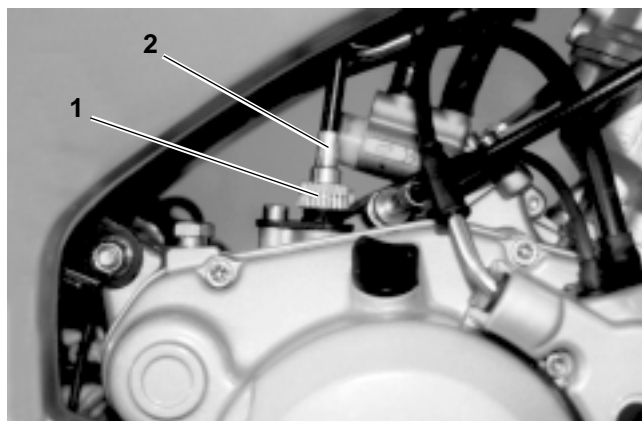

Slide the boot (3) back.
Loosen the nut (4) by screwing it counterclockwise.
Turn in the adjuster (5) to slacken the clutch cable.

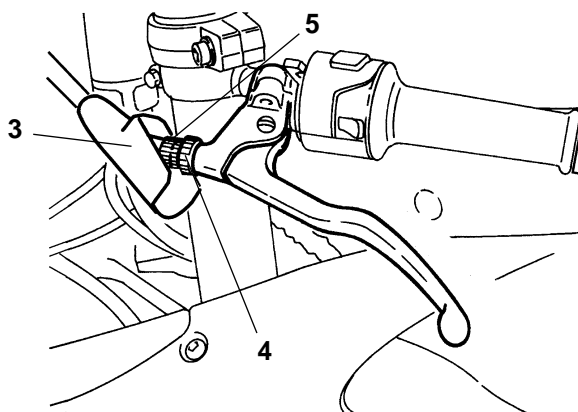

Push the clutch lever (6) on the engine and disconnect the clutch cable (7).

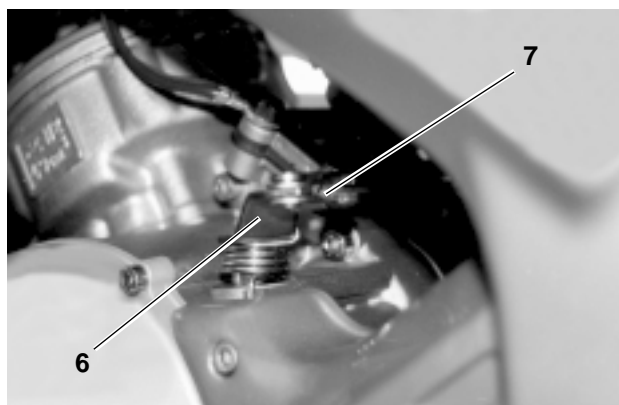

Loosen and remove the two screws (8) that secure the oil pump cover.
Remove the oil pump cover (9).

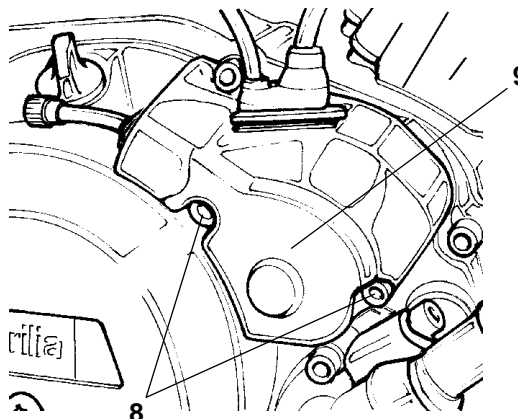

Disconnect the oil pump control cable (10) and withdraw the cable from the wire guide (11). After withdrawing the oil line grommet, loosen and slide back the clamp (12) and withdraw the oil inlet tube (13).

NOTE Plug the end of the oil inlet tube (13) immediately with a screw of suitable diameter to stop the oil coming out.

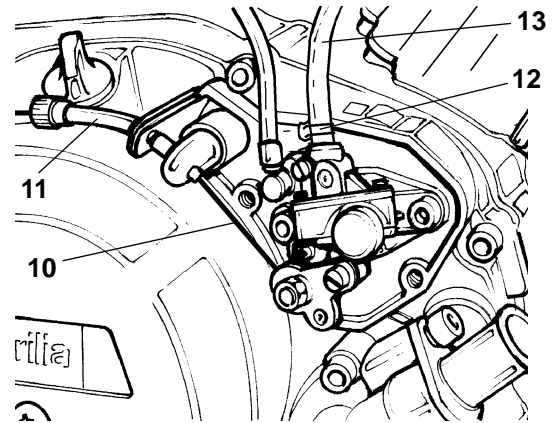

▲ WARNING

Wash your hands thoroughly after handling oil. Dispose of used oil properly.

KEEP OUT OF REACH OF CHILDREN.

Remove the screw (14) and withdraw the water pump inlet hose (15) along with the connected hoses.

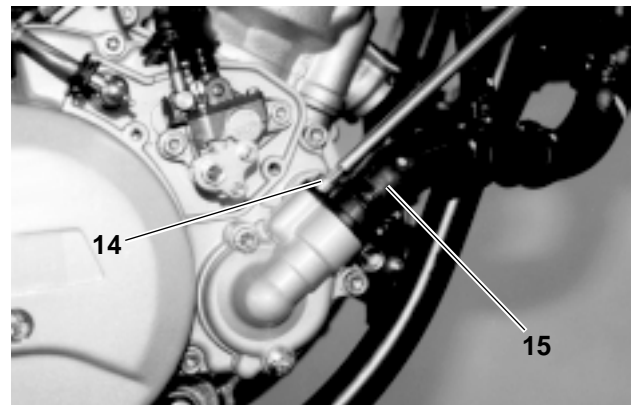

Remove the four screws (16) and withdraw the inlet manifold (17).

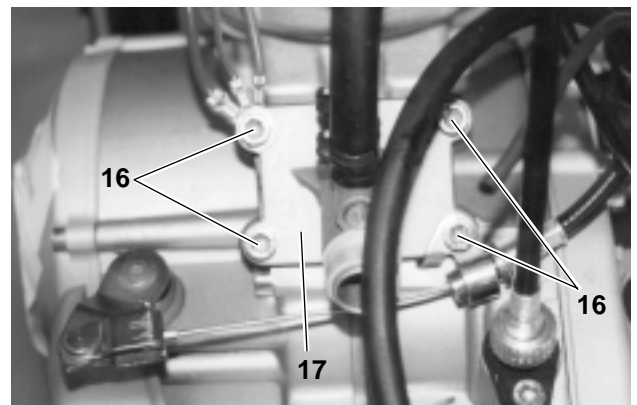

Remove the electrical connection (18) from the thermistor (19).

Disconnect the spark plug cap (20).

Remove the clamp (21) from the cylinder head-radiator coolant hose (22) and disconnect the hose.

Remove the clamp (23) from the heater hose (24) and disconnect the hose.

▲ WARNING

Use new clamps (21) and (23) when refitting the hoses.

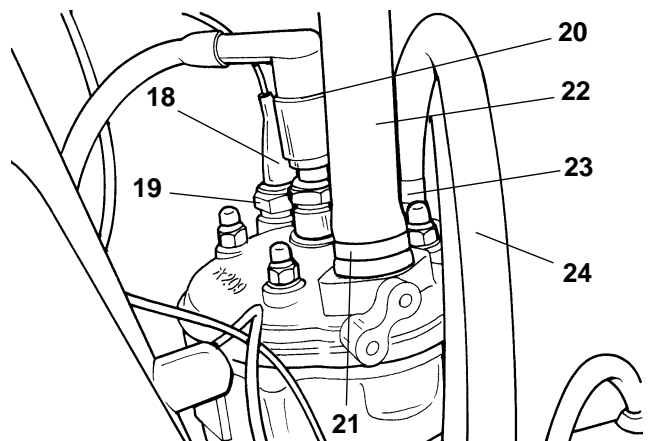

▲ WARNING

Remove all the clamps all the way along the cables and hoses.

Prepare the same number of new clamps for refitting the cables and hoses.

Plug all the openings in the engine, tubes and hoses to prevent foreign bodies from getting in the way.

Group the electric cables together and fasten them with adhesive tape to stop them getting in the way when removing the engine in a downward direction.

Disconnect the electrical connection (25) from the starter motor and magneto.

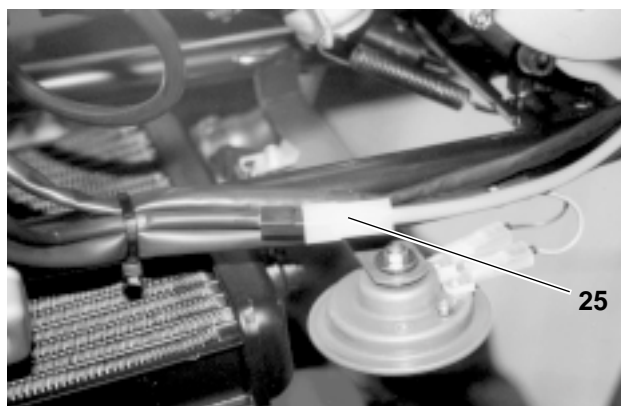

Unscrew the two screws (26) to remove the sprocket guard (27).

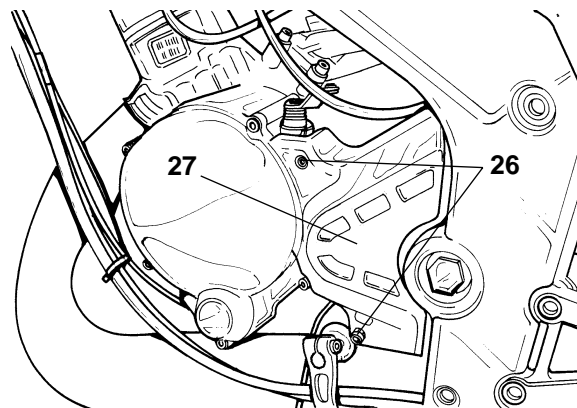

Remove the chain (28) (REMOVING THE DRIVE CHAIN).

Unscrew and remove the ground lead (30) retainer screw (29).

Unscrew the screw (31) and withdraw the gearbox drive connecting rod (32) from the selector shaft (33).

Unscrew and remove the 5 screws (34) to remove the flywheel casing cover (35).

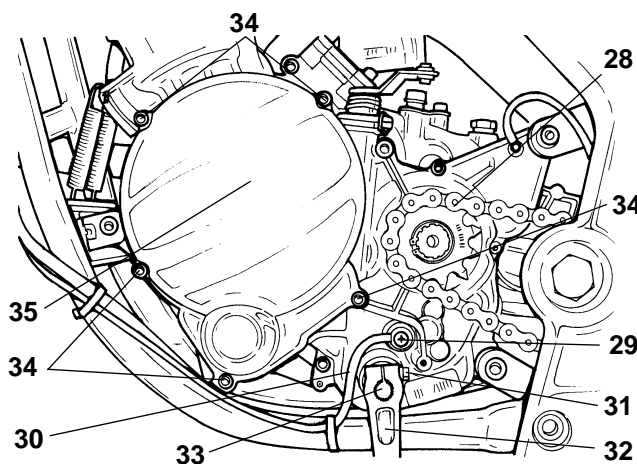

Unscrew and remove the 2 screws (36) and unscrew the screw that holds the bracket on the back of the starter motor.

Remove the starter motor (37).

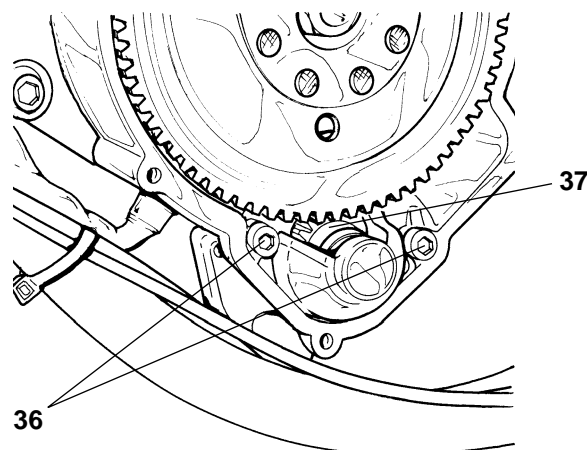

3

Remove the engine cradle (38) (REMOVING THE ENGINE CRADLE).

Prepare a hoist and straps for lifting.

▲ WARNING

The hoist and straps must be strong enough to bear the weight of the engine in complete safety. Failure to use appropriately strong straps could allow the engine to fall with subsequent damage to the engine and possible personal injury to you. Attach the straps to the hoist and to the engine.

Couple the straps to the hoist and sling up the engine.

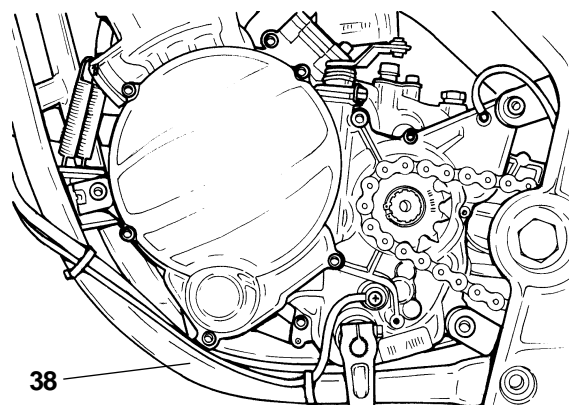

▲ CAUTION

The straps must be attached to the engine and to the hoist in a secure and stable manner so that the lifting can be done in complete safety. Raise the hoist arm so that the straps take all of the engine weight off of the engine mounting bolts.

Raise up the hoist arm so that the straps take the strain of the engine weight.

▲ CAUTION

Raise the hoist arm just enough to hold the engine in position to allow for the removal of the engine mounting bolts.

Remove the two engine mounting bolts from the frame (39), and remove the washers and self-locking nuts from the opposite side.

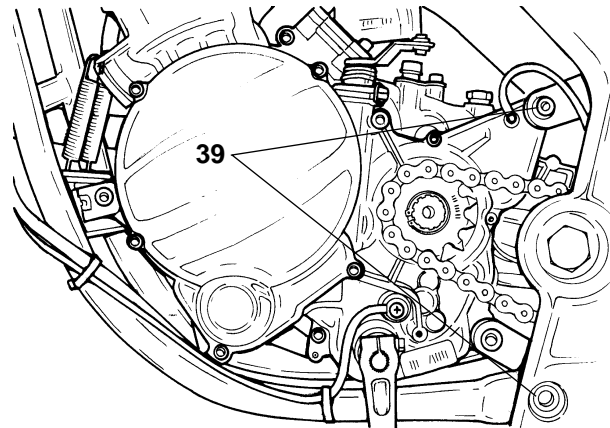

▲ CAUTION

The engine is now free and not fastened at any point.

Handle it with care; be careful about your fingers and limbs.

Remove any loose tools from the area of ground where the engine is to be put down and clean it thoroughly.

Raise the hoist arm a few millimeters to “unlock” the engine from the frame.

Lower the hoist arm and rest the engine on the ground.

Make sure the engine is properly balanced on the ground and won't tip over.

Remove the straps from the hoist and the frame.

NOTE If no work is to be done on the engine, it is permissible to leave the straps attached to the engine and the hoist.

Clean the outside of the engine thoroughly.

▲ CAUTION

Use a mild detergent, bristle brushes and cloths to clean the outside of the engine.

Do not use acidic, highly alkaline or solvent-based cleaners which can damage the rubber and plastic parts particularly.

Fuel supply system

4

FUEL TANK

The fuel tank is equipped with a filler cap, and a fuel valve. The valve, as shown in the figure, has three positions (OFF, ON and RES), which may be selected with the valve lever.

When the lever is in the ON position (normal), the main passage is open. When the lever is in the RES position, the auxiliary fuel reserve passage is open. When the lever is in the OFF position, both passages are closed.

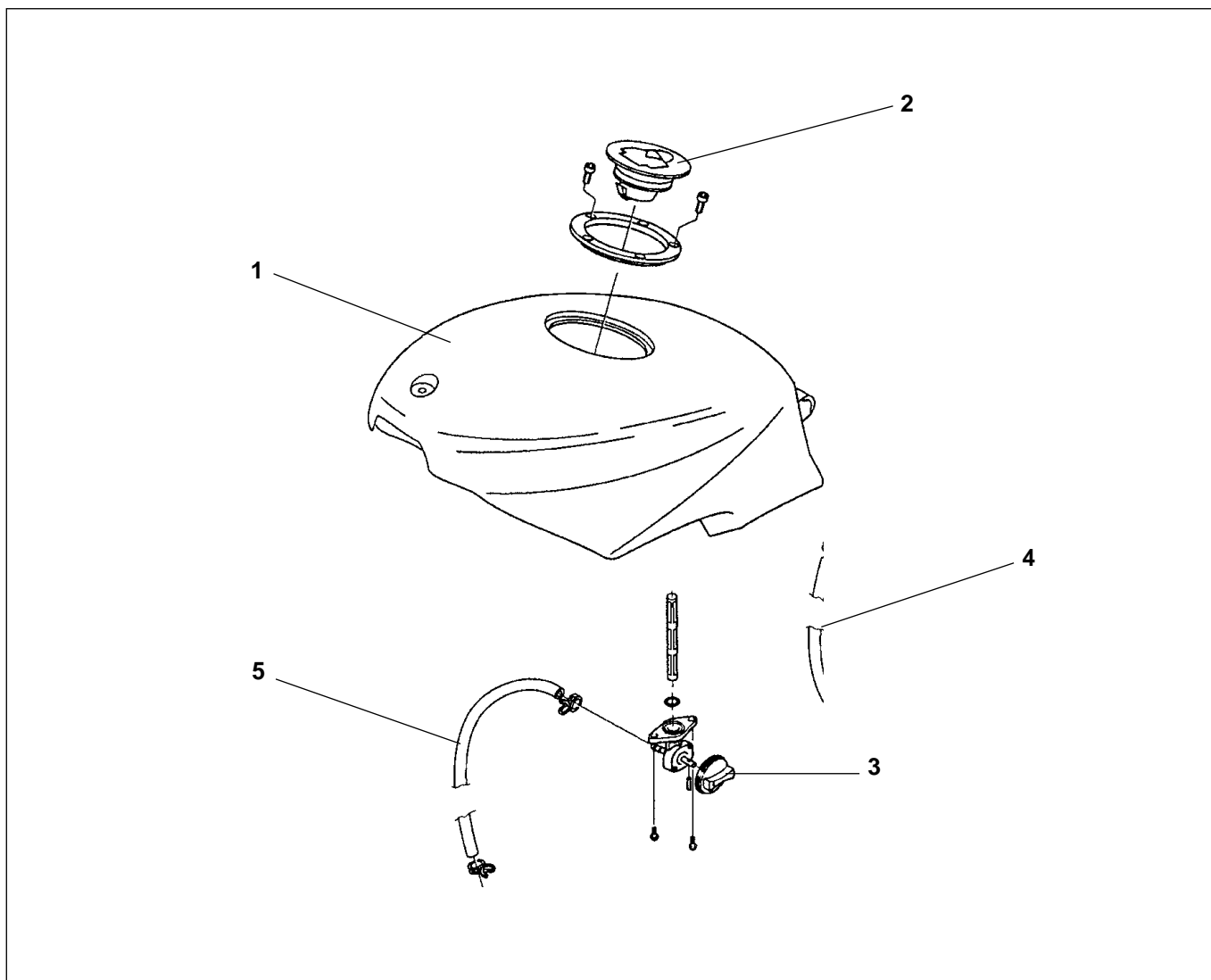

Key

- 1) Fuel tank
- 2) Filler cap
- 3) Fuel valve
- 4) Water drain tube
- 5) Fuel delivery tube

Read carefully (PRECAUTIONS AND GENERAL INFORMATION) and (FUEL).



MAINTENANCE

To service the tank, it has to be removed (REMOVING THE TANK) and washed completely.

4

CHECKING THE FUEL FEED

Check the fuel pipes/hoses every 4,000 Km (2,500 miles) or 8 months.

Any pipes/hoses that show cracks or cuts must always be replaced.

If you see a fuel leak in the vicinity of the fuel valve, this could be because of a damaged O-Ring gasket.

Remove the fuel valve (REMOVING THE FUEL VALVE), check its condition and, if necessary, replace with a new one.

Open the filler cap and make sure the fuel tank breather is not blocked. If necessary, unblock it with a compressed air jet.

REMOVING THE FUEL VALVE

Raise up the tank (RAISING THE FUEL TANK).
Remove the screws (1) and extract the complete fuel valve (2).
Reposition the petrol cock (2) under the tank and screw in the two screws (1).

Torque setting for screws (1):
4 Nm (0.6 kgm).

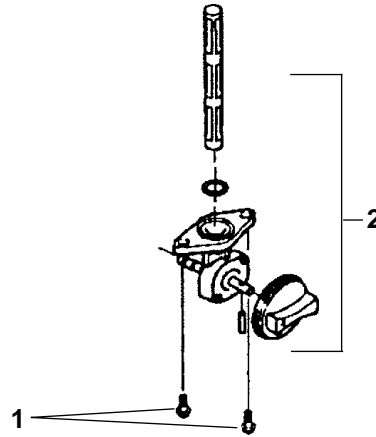

REMOVING THE CARBURETOR

Reads carefully (PRECAUTIONS AND GENERAL INFORMATION).

Partially remove the fuel tank (RAISING THE FUEL TANK).
Remove the air box (REMOVING THE AIR BOX).
Remove the clamp (3) from the inlet tube (4) coming from the oil pump and disconnect the tube.
Remove the two screws (5) from the throttle control cover (6) and remove the cover.
Remove the clamp (7) from the fuel hose (8) and disconnect the hose.
Remove the screw from the carburetor manifold.

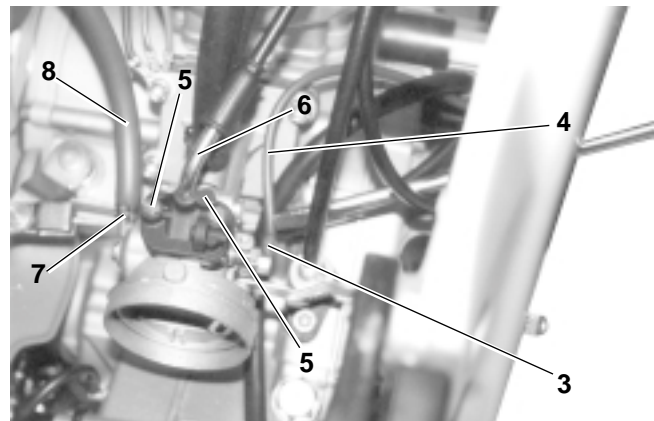

⚠ CAUTION

Danger of fuel splashing out.

Plug the free end of the fuel hose (8) and fasten it to the motorcycle in a vertical position.
Loosen the screw that attaches the carburetor to the reed valve manifold and take off the carburetor.

NOTE Before refitting, check the condition of the fuel and oil lines (FUEL LINES, 2 STROKE OIL PIPES/HOSES).

Fit the carburetor into the reed valve manifold and secure it with the screw.

Connect the carburetor hose (8) and secure it to the carburetor with the clamp (7).

Connect the oil feed tube coming from the pump (4) and secure it with the clamp (3).

Fit the throttle control cover (6) and secure it with the two screws (5).

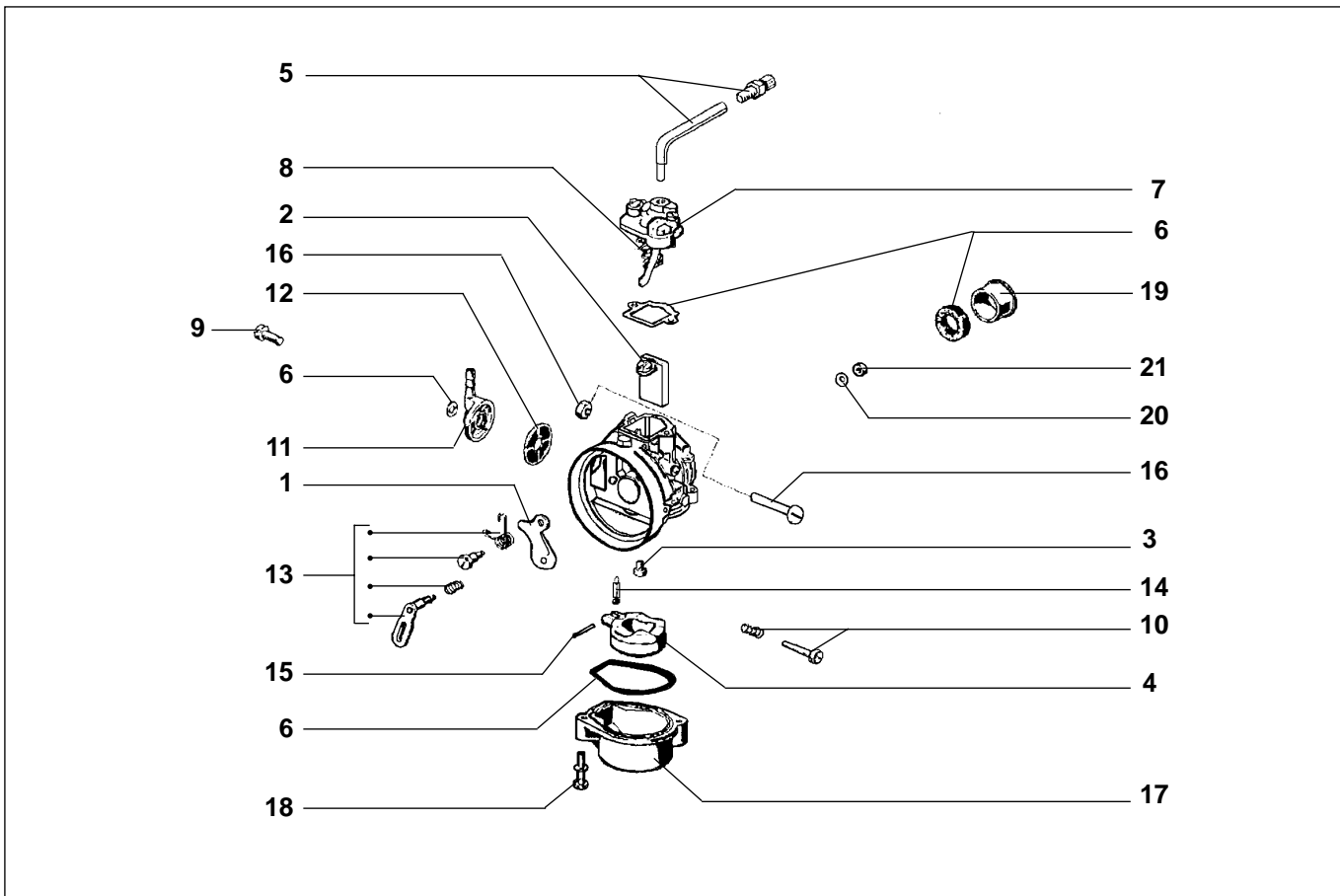

DESCRIPTION

- 1)Choke
- 2)Throttle valve
- 3)Main jet
- 4)Float
- 5)Deflector tube kit
- 6)Gaskets
- 7)Valve cover
- 8)Throttle valve return spring
- 9)Connection fitting retainer screw
- 10)Throttle valve adjustment screw
- 11)Fuel line connection fitting
- 12)Fuel filter
- 13)Choke control shaft
- 14)Needle
- 15)Float pin
- 16)Clamp screw
- 17)Float chamber
- 18)Float chamber retainer screw
- 19)Adapter
- 20)Choke shaft washer
- 21)choke shaft nut

Specifications

Version	Dellorto Carburetor	
Type	SHA 1412 M	
Choke	Ø12 mm	(0.47 in)
Main jet	63 mm	(2.48 in)
Level in float chamber	4.0 mm	(0.16 in)
Float needle	1.2 mm	(0.05 in)
Float weight	3.5 gr	(0.12 oz)
Starter valve	50	(1.96 in)
Choke screw	3.5 turns	(3.5 turns)
Inlet manifold	14 mm	(0.55 in)

REMOVING THE 2 STROKE OIL TANK

Read carefully (**PRECAUTIONS AND GENERAL INFORMATION**).

Remove the rider and passenger saddle (**REMOVING THE RIDER AND PASSENGER SADDLE**).

Remove the fuel tank (**REMOVING THE FUEL TANK**).

Remove the rear fairing (**REMOVING THE REAR FAIRING**).

Remove the right and left pillar covers (**REMOVING THE PILLAR COVER**).

Remove the battery and fuses (**REMOVING THE BATTERY**).

Remove the oil from the two stroke oil tank (**REMOVING THE OIL FROM THE TWO STROKE OIL TANK**).

Loosen and remove the 4 flanged screws (1) that secure the two stroke oil tank to the frame.

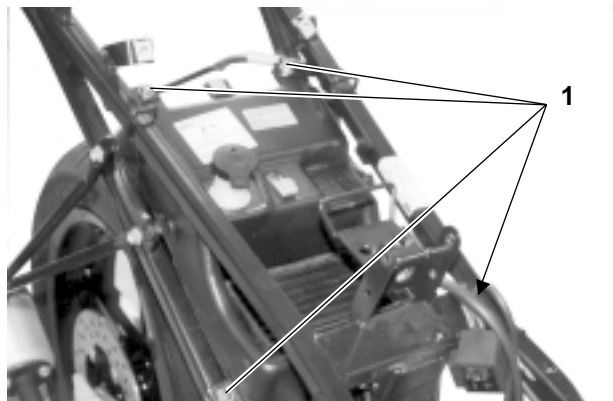

Disconnect the oil reserve level indicator electrical connections (2).

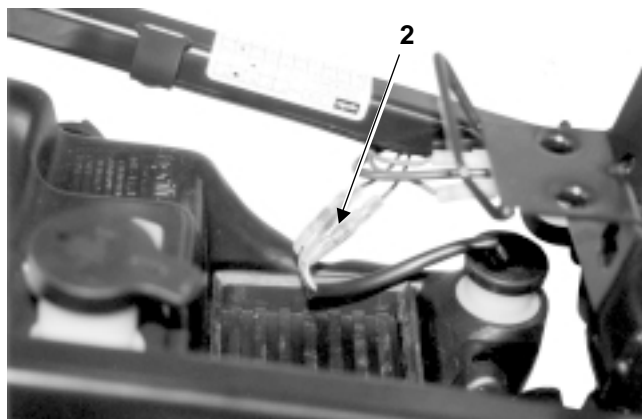

Remove the clamp (3) and disconnect the tube (4) that delivers oil to the pump.



To remove the two stroke oil tank (5), rotate it towards the rear of the frame as you lift it out.

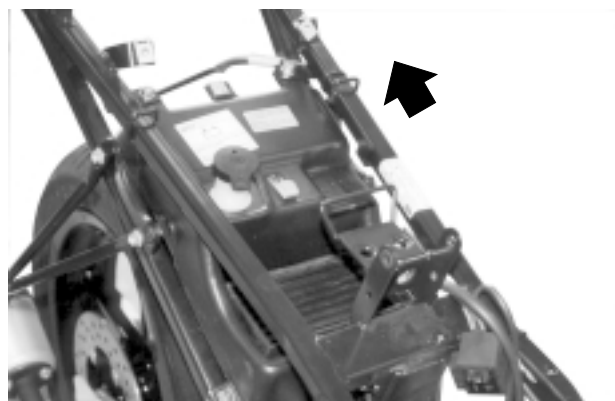

4

Reposition the two stroke oil tank in its housing, securing it to the frame with the two flanged screws (1).

**Torque wrench settings for flanged screws (1):
6 Nm (0.6 kgm) [4.4 Ft-lb].**

Connect the oil delivery tube (4) to the tank and secure it with a new clamp (3).

Connect up the oil reserve level indicator electrical connections (2).

Cooling system

5

REMOVING THE RADIATOR

Read carefully (PRECAUTIONS AND GENERAL INFORMATION) and (COOLANT).

Remove the r.h side fairing (REMOVING THE SIDE FAIRINGS).

Remove the saddle cowl (REMOVING THE SADDLE COWL).

Drain all the coolant from the cooling system (CHANGING THE COOLANT).

Remove the clamp (1) from the pump-radiator hose (2) and disconnect the hose.

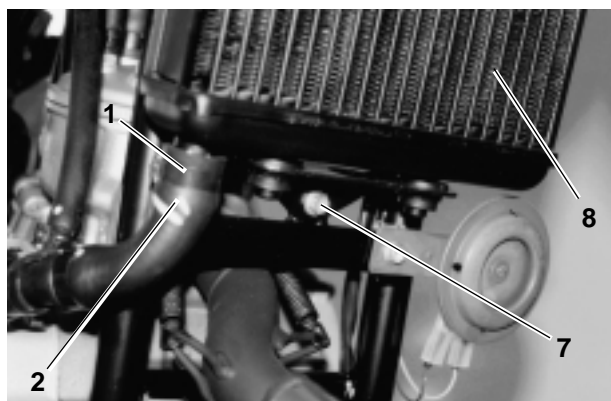

Remove the clamp (3) from the cylinder head-radiator hose (4) and disconnect the hose.

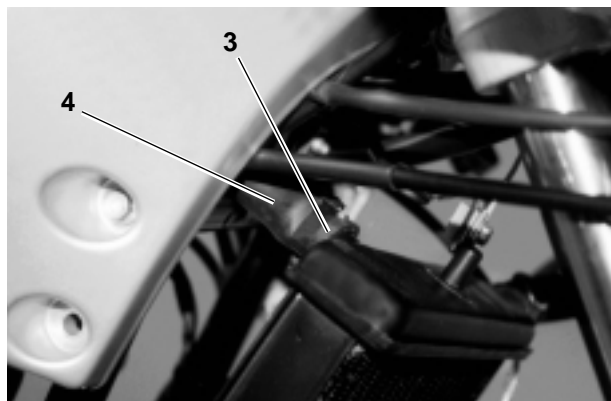

Remove the clamp (5) from the radiator filler hose (6) and disconnect the hose.

▲ WARNING

Proceed with care. Do not damage the radiator fins.

Remove the flanged screw (7) from the radiator support and take out the radiator (8) in a downward direction.

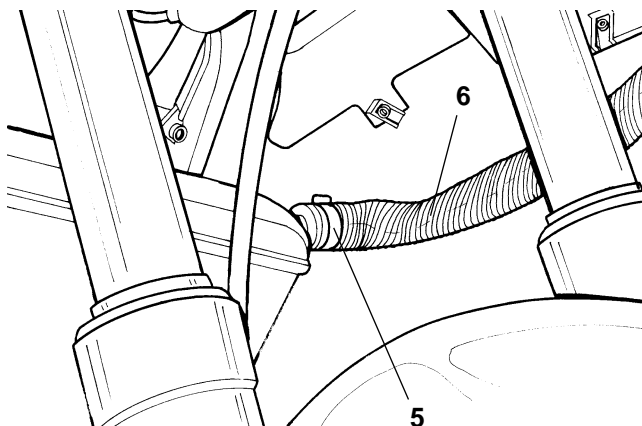

▲ WARNING

Plug the ends of the hoses, to prevent foreign bodies from getting into them.

NOTE Replace the rubber pads (9) if worn.

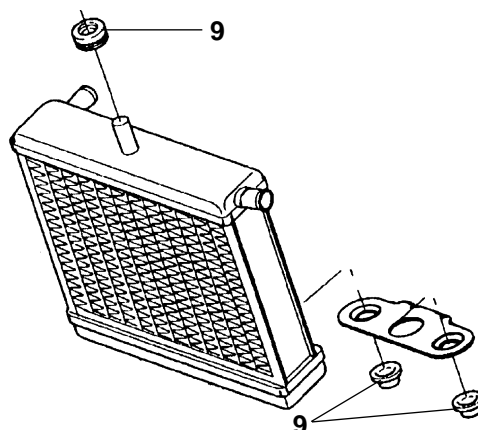
**▲ CAUTION**

Any foreign material, dirt etc. that is stuck to the radiator fins must be removed with a blast of compressed air.

Any bent fins must be straightened using a small flat-bladed screwdriver.

Replace the hoses if they show any signs of abrasion, checking or cracking.

Wash out the inside of the radiator thoroughly before refitting it, using clean water only.

To refit, follow the removal steps in reverse order, replacing the hose clamps.

5**REMOVING THE FILLER CAP**

Read carefully (PRECAUTIONS AND GENERAL INFORMATION) and (COOLANT).

Remove the l.h. side fairing (REMOVING THE SIDE FAIRINGS).

Remove the dashboard closing cowl (2) retainer screw (1).

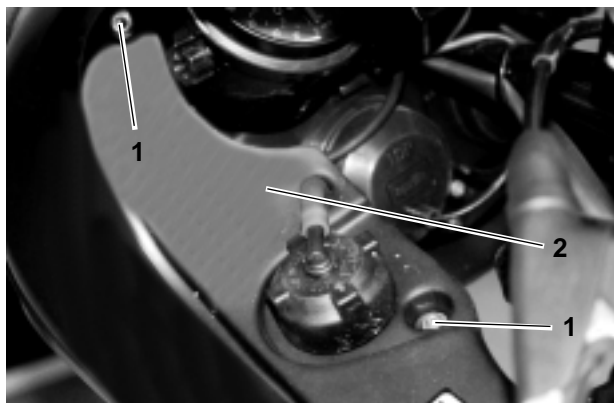

Loosen and remove the clamp (3) from the filler hose (4), then disconnect the hose.

Unscrew the filler cap (5), remove the screw (6) and withdraw the filler (7).

▲ WARNING

Plug the hose covers to prevent foreign material from entering.

NOTE Replace the filler hose (4) with a new one if damaged.

To refit, follow the removal steps in reverse order.

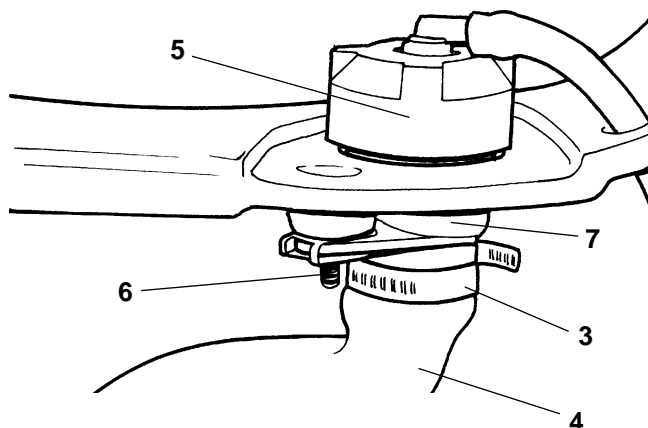

INTRODUCTION

Read carefully (**PRECAUTIONS AND GENERAL INFORMATIONS**) and (**BATTERY**).

The information below will be useful when consulting this section.

NOTE The numbering in the specific wiring diagrams corresponds to that in the main wiring diagram.



RECOMMENDED EQUIPMENT

Multimeter,
Hydrometer for battery electrolyte,
Timing light for 2-stroke engines, 10,000 RPM
0 to 100A direct current ammeter
130Ω 2W resistor

WIRE COLORS

Ar	orange
Az	Light blue
B	blue
Bi	white
G	yellow
Gr	gray
M	brown
N	black
R	red
Ro	pink
V	green
Vi	purple

MAIN WIRING DIAGRAM

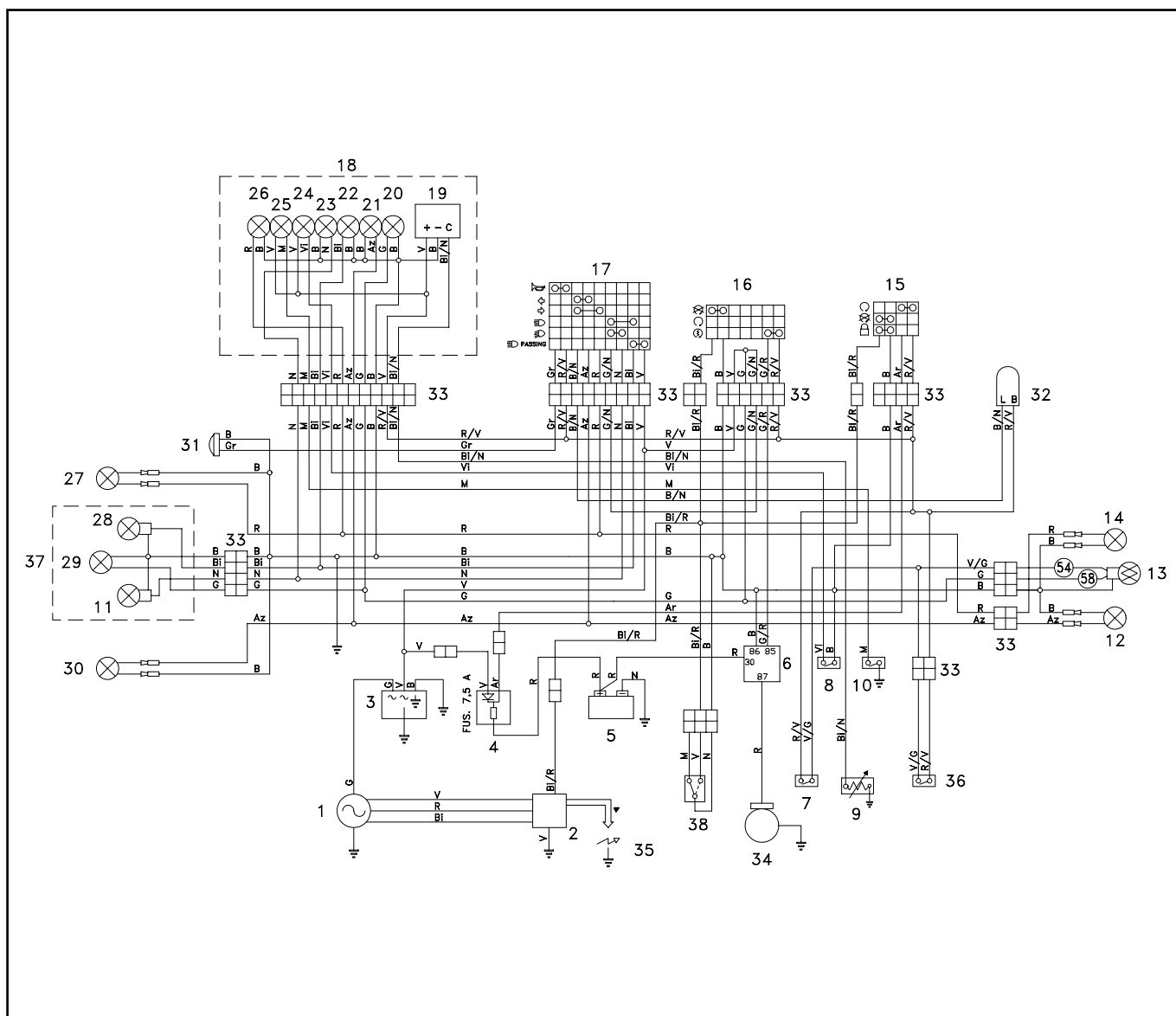

6

MAIN WIRING DIAGRAM KEY

- | | |
|---------------------------------------|--|
| 1) Generator | 21) Left turn signal warning light |
| 2) Ignition coil | 22) High beam warning light |
| 3) Voltage regulator | 23) Low beam warning light |
| 4) Rectifier | 24) Two stroke oil reserve warning light |
| 5) Battery | 25) Neutral gear warning light |
| 6) Starter relay | 26) Right turn signal warning light |
| 7) Brake light rear switch | 27) Right front turn signal light |
| 8) Two stroke oil tank reserve sensor | 28) High beam light |
| 9) Coolant temperature thermistor | 29) Front parking light |
| 10) Neutral gear sensor | 30) Left front turn signal light |
| 11) Low beam light | 31) Horn |
| 12) Rear left turn signal light | 32) Flasher |
| 13) Taillight | 33) Multiple connector |
| 14) Rear right turn signal light | 34) Starter motor |
| 15) Ignition switch | 35) Spark plug |
| 16) Right high/low beam selector | 36) Brake light front switch |
| 17) Left high/low beam selector | 37) Headlight |
| 18) Dashboard | 38) Side stand switch |
| 19) Coolant temperature gauge | |
| 20) Dashboard lights | |

LOCATION OF COMPONENTS

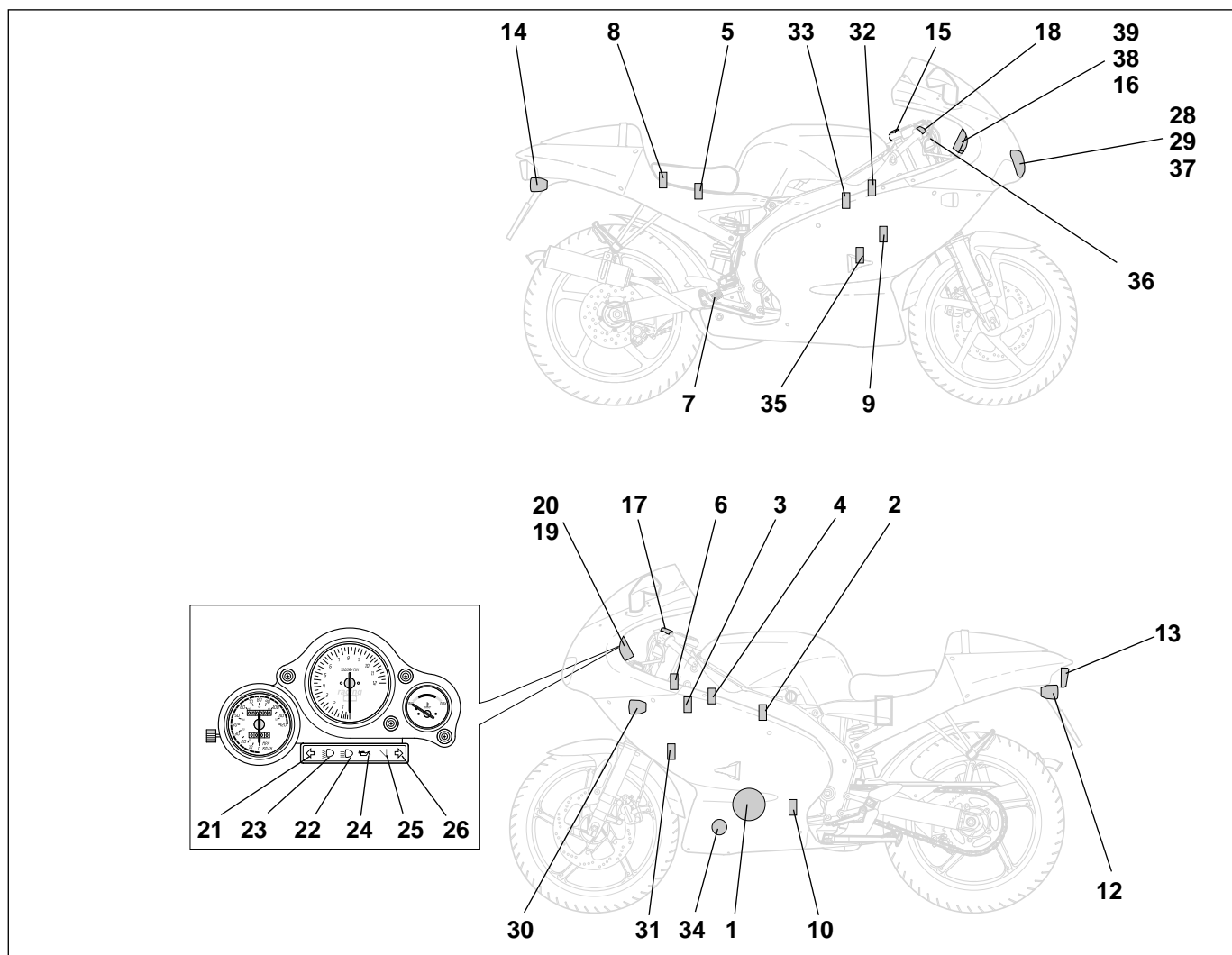

KEY

- | | |
|---------------------------------------|--|
| 1) Generator | 21) Left direction indicators warning light |
| 2) Ignition coil | 22) High beam warning light |
| 3) Voltage regulator | 23) Low beam warning light |
| 4) Rectifier | 24) Two stroke oil reserve warning light |
| 5) Battery | 25) Neutral gear warning light |
| 6) Starting relay | 26) Right direction indicators warning light |
| 7) Brake light rear switch | 27) Front right direction indicator |
| 8) Two stroke oil tank reserve sensor | 28) High beam light |
| 9) Coolant temperature thermistor | 29) Front parking light |
| 10) Neutral gear sensor | 30) Front left direction indicator |
| 11) Low beam light | 31) Horn |
| 12) Rear left direction indicator | 32) Flasher |
| 13) Taillight | 33) Multiple connector |
| 14) Rear right direction indicator | 34) Starter motor |
| 15) Ignition switch | 35) Spark plug |
| 16) Right high/low beam selector | 36) Brake light front switch |
| 17) Left high/low beam selector | 37) Headlight |
| 18) Dashboard | 38) Right high/low beam selector with engine stop switch (in designated countries) |
| 19) Coolant temperature gauge | 39) Right high/low beam selector <small>ASD</small> |
| 20) Dashboard lights | |

IGNITION CIRCUIT

Location of components see (LOCATION OF COMPONENTS).

WIRING DIAGRAM

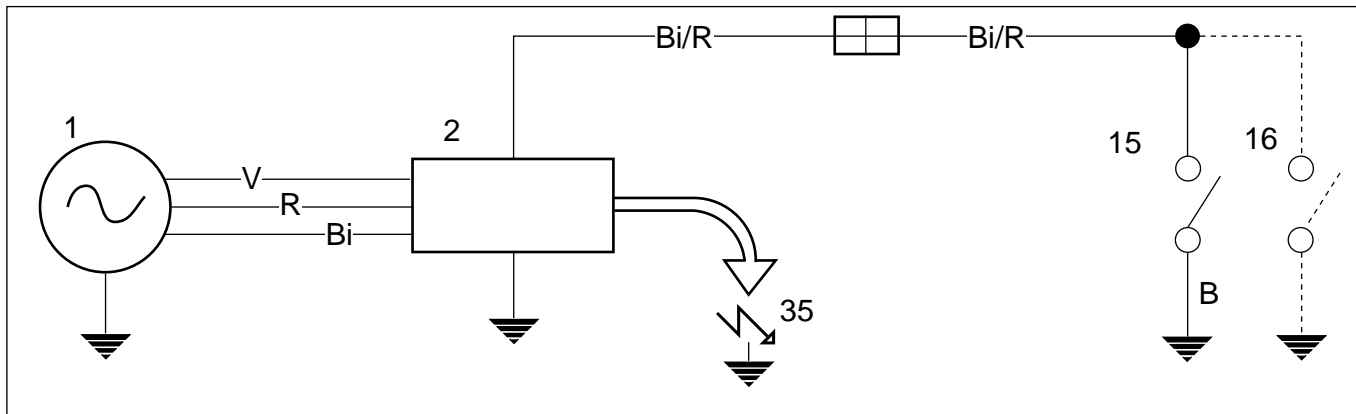

- 1) Generator
- 2) Coil
- 35) Spark plug
- 15) Ignition switch
- 16) Right high/low beam selector 

TECHNICAL DATA

Spark plug	NGK R BR9ES
Spark gap	0.6 ± 0.7 mm (0.02 ± 0.03 in)
Spark advance	14° ± 2° before T.D.C.
Type of ignition	C.D.I. (fixed advance)

TROUBLESHOOTING

A. ENGINE DOESN'T RUN PROPERLY OR THERE IS NO SPARK

Check the condition of the spark plug, replacing it if necessary.

Disconnect the red-white wire from the ignition switch, taking care not to ground it accidentally.

Check the wire connections.

If the fault persists:

Check the H.T. lead.

Check the spark plug cap.

Check the magneto flywheel (CHECKING THE MAGNETO FLYWHEEL).

Replace the coil with one that you know is good.

If the fault ceases:

Check the ignition switch (CHECKING THE IGNITION SWITCH).

B. ENGINE DOESN'T STOP

Check the connection between the ignition switch and the white-red wire.

CHECK DATA

Using a multimeter switched to the ohm scale, check the continuity between the wires, keeping to the stated polarities.

CHECKING THE MAGNETO FLYWHEEL

Pick-up coil:

between red and white wires $120 \Omega \div 20 \%$.

Condenser charge coil:

between green and white wires $700 \Omega \div 20 \%$.

**CHECKING
THE IGNITION SWITCH**

Disconnect the ignition switch connector.

Using a multimeter switched to the ohm scale, test the continuity between the various wires in the connections (MAIN WIRING DIAGRAM).

RECHARGE AND GENERAL POWER SUPPLY CIRCUIT

Location of components see (LOCATION OF COMPONENTS).

WIRING DIAGRAM

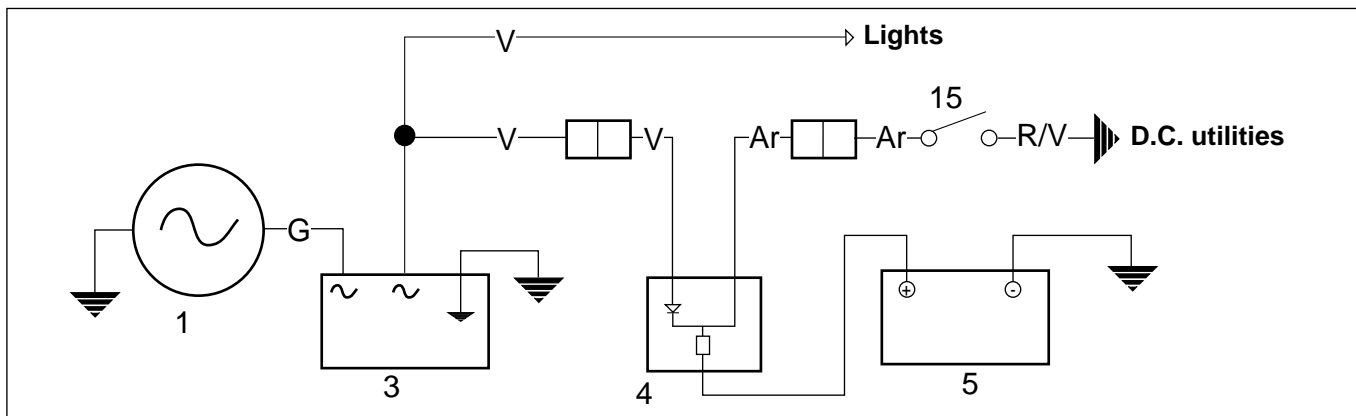

- 1) Generator
- 3) Voltage regulator
- 4) Rectifier
- 5) Battery
- 15) Ignition switch

TECHNICAL DATA

Generator	105 W a.c. a 6000 rpm
Voltage regulator	12 V a.c.
Battery	4 Ah - 12V
Fuse	7.5 A

CHECKING THE RECHARGING

Start the engine.

Using the multimeter, set to D.C. volts, check the battery voltage.

At 6000 rpm the voltage reading should be between 13.5 and 15 V with the headlight on low beam.

TROUBLESHOOTING

A. BATTERY DOESN'T STAY CHARGED

Check the fuse, replacing it if necessary.

Replace the rectifier.

Check the wiring connections on the regulator, fly-wheel, battery and fuse.

Check the battery (CHECKING THE BATTERY).

Check the generator (CHECKING THE GENERATOR).

B. EXCESSIVE CHARGING VOLTAGE

Check the voltage regulator (CHECKING THE VOLTAGE REGULATOR).

Check the wiring connections.

C. VOLTAGE DOESN'T REACH D.C. LOADS (green/red wires)

Check the fuse, replacing it if necessary (CHANGING THE FUSE).

Check the wiring connections on the regulator, fly-wheel, battery and fuse.

Check the battery (CHECKING THE BATTERY).

Check the generator (CHECKING THE GENERATOR).

Check the ignition switch (CHECKING THE IGNITION SWITCH) and its connections.

D. ELECTRICAL SYSTEM FUNCTIONS BADLY

Check the ground connections.

CHECK DATA**CHECKING THE GENERATOR**

Disconnect the yellow wire from the regulator.

Start the engine and run it at 6000 rpm.

Using a tester in A.C. voltmeter mode, test the voltage between:

generator yellow and ground wires = reading

greater than 35 V.

Using a tester in A.C. ammeter mode, test the current between:

generator yellow and ground wires = reading

greater than 5 A.

CHECKING THE BATTERY

Voltage without load 12.5 ± 1 V.

Electrolyte density 1.26 at 20°C (68°F).

Check the electrolyte level, topping up with distilled water if necessary.

Check that there are no signs of sulphation; replace if necessary.

6**STARTER CIRCUIT**

Location of components see (LOCATION OF COMPONENTS).

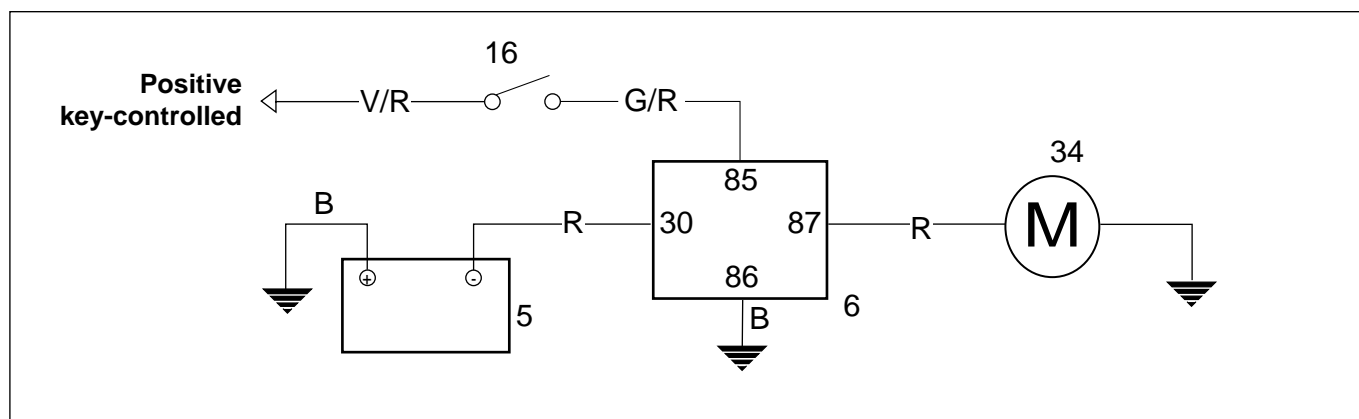
WIRING DIAGRAM

- 5) Battery
- 6) Starter relay
- 16) Starter button
- 34) Starter motor

TECHNICAL DATA

Starter motor	12 V - 150 W
Brush wear limit	0.9 mm (0.03 in)
Starter relay	12 V - 70 A
Battery	12 V - 4 Ah

TROUBLESHOOTING**A. STARTER MOTOR DOESN'T TURN OR TURNS VERY SLOWLY**

- Check the battery (CHECKING THE BATTERY).
- Check the circuit (wiring and connectors).
- Check the starter relay (CHECKING THE STARTER RELAY).
- Check the starter button "ⓘ" (CHECKING THE STARTER BUTTON).
- Check the general power supply circuit.

B. STARTER MOTOR TURNS BUT ENGINE DOESN'T TURN OVER

- Check the starter motor gears (CHECKING THE STARTER MOTOR).

C. STARTER MOTOR TURNS BY ITSELF, WITHOUT PRESSING THE BUTTON

- Check the starter motor wiring connections.
- Check the starter relay (CHECKING THE STARTER RELAY).
- Check the starter button "ⓘ" (CHECKING THE STARTER BUTTON).

CHECK DATA**CHECKING THE STARTER RELAY**

Disconnect all the wires from the relay.

Using a multimeter with the scale set to ohms, test the continuity between terminals 30 and 87.

Exact value: infinity.

Apply voltage to terminals 85 and 86 with a 12 V battery. Using a tester in ohmmeter mode, test the continuity between terminals 30 and 87.

Exact value: 0 Ω .

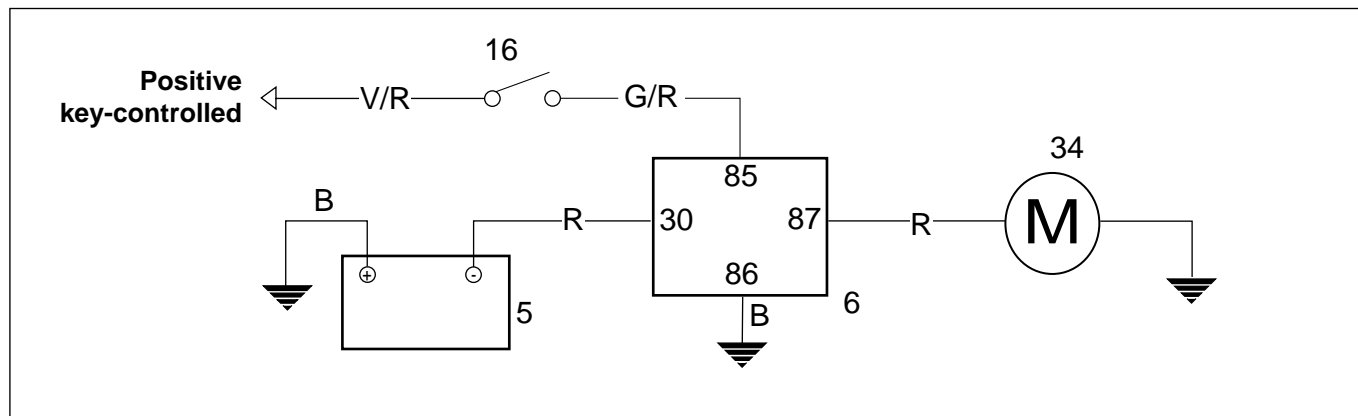

- 5) Battery
- 6) Starter relay
- 16) Starter button
- 34) Starter motor

6**CHECKING THE STARTER BUTTON**

Check the starter motor input current with a 0 \pm 100 A a.c. ammeter, after removing the spark plug cap, so that the engine won't start.

Normal values: 25 A starting, 20 A at running speed \pm 15 %.

Using a multimeter with the scale set to ohms, check the resistance between the positive and negative terminals of the starter motor.

Normal value: 0.5 Ω \pm 10 %.

CHECKING THE STARTER BUTTON “①”

Disconnect the button connector.

Using a tester in ohmmeter mode check the continuity between the contacts in the pressed and rest positions by testing the connections (MAIN WIRING DIAGRAM).

SENSOR CIRCUIT

Location of components see (LOCATION OF COMPONENTS).

WIRING DIAGRAM

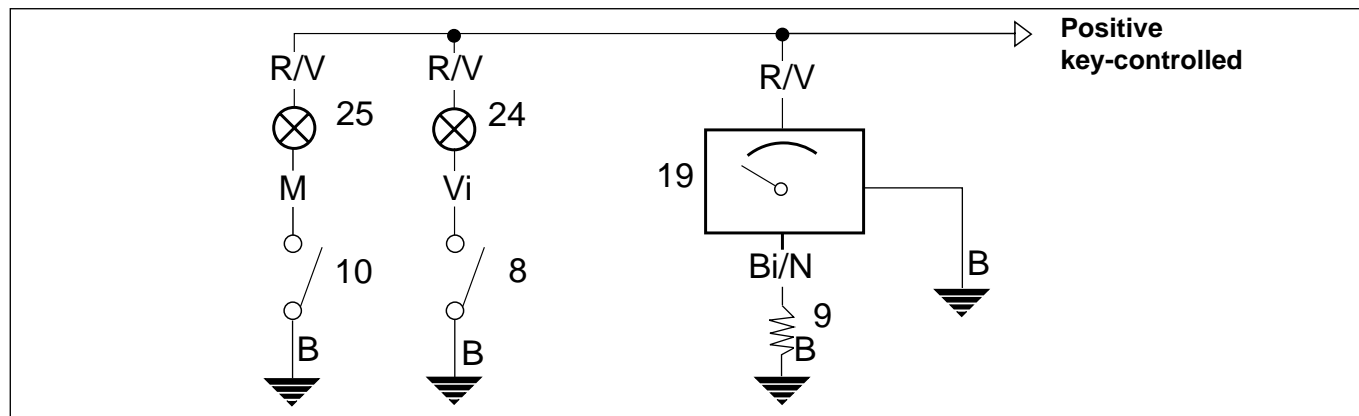

- 8) Oil reserve sensor
- 9) Water temperature thermistor
- 10) Neutral gear sensor
- 19) Water temperature gauge
- 24) Oil reserve warning light
- 25) Neutral gear warning light

TECHNICAL DATA

All-glass type
warning light bulbs 12 V - 2 W, W2.1x9.5d

TWO STROKE OIL RESERVE WARNING LIGHT

TROUBLESHOOTING

A. LOW OIL LEVEL WARNING LIGHT DOESN'T LIGHT UP

Check the bulb.

Check for voltage on the oil warning light green/red wire.

Check the wiring connections.

Check the oil level sensor (CHECKING THE OIL LEVEL SENSOR).

B. STAYS LIT WHEN OIL LEVEL IS SUFFICIENT

Check the wiring connections.

Check the oil level sensor (CHECKING THE OIL LEVEL SENSOR).

CHECK DATA**CHECKING THE OIL LEVEL SENSOR**

Disconnect the sensor wires and remove the sensor from the tank.

Set the multimeter to the ohm scale, and connect the leads to the sensor wires.

In its upside position, you should read a value of infinity.

In its normal position, it should read 0 ohms.

6**DIRECTION INDICATORS CIRCUIT**

Location of components see (LOCATION OF COMPONENTS).

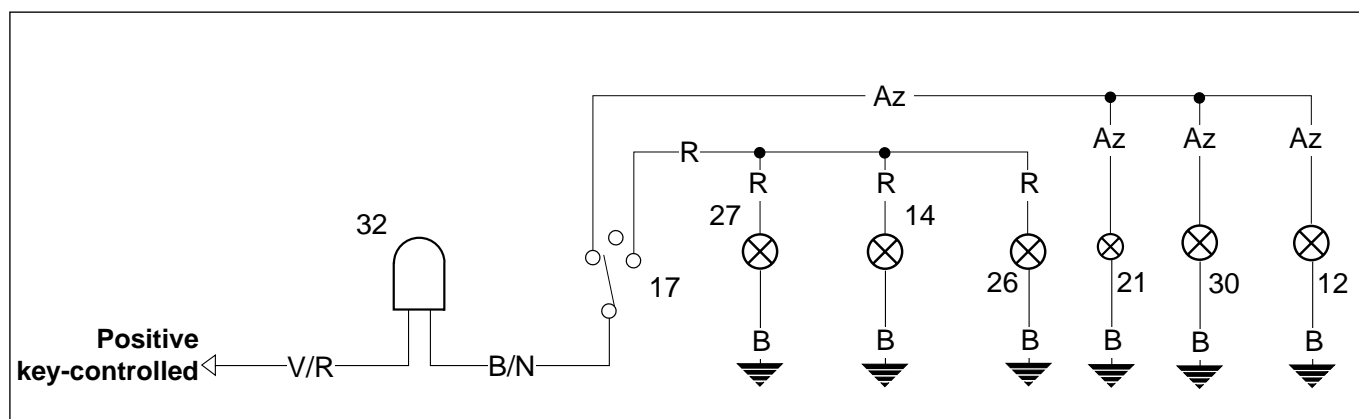
WIRING DIAGRAM

- 12) Left rear turn signal
- 14) Right rear turn signal
- 17) Turn signal selector
- 21) Left turn signal warning light
- 26) Right turn signal warning light
- 27) Right front turn signal
- 30) Left front turn signal
- 32) Flasher

TECHNICAL DATA

Direction indicator

bulbs 12 V - 10 W B.A. 15 S

Flasher 12 V - 22 W

All-glass type direction indicator

warning light bulbs 12 V - 2 W - W2.1x9.5d

TROUBLESHOOTING

A. INDICATORS DON'T WORK

Check the bulbs.

Check the wiring connections.

Check the turn signal selector.

Check the general power supply circuit.

Replace the flasher.

B. INDICATORS STAY LIT PERMANENTLY, WITHOUT FLASHING

Check bulb specifications.

Check the battery (CHECKING THE BATTERY).

Replace the flasher.

CHECK DATA

CHECKING THE DIRECTION INDICATOR SELECTOR

Check the continuity of the bulbs.

Disconnect the selector connector.

Using a multimeter with the scale set to ohms, check the continuity between the wires in the different positions by testing the connections see (MAIN WIRING DIAGRAM).

HORN CIRCUIT

Location of components see (LOCATION OF COMPONENTS).

WIRING DIAGRAM

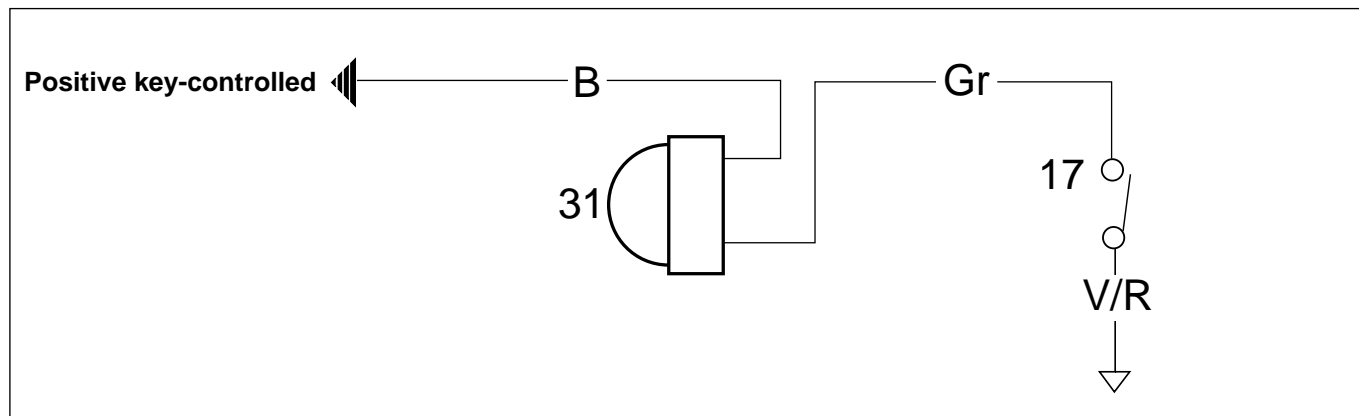

17) Horn button

31) Horn

6

TECHNICAL DATA

Horn 12 V c.c.

TROUBLESHOOTING

A. DOESN'T SOUND, OR SOUNDS BADLY

Check the battery (CHECKING THE BATTERY).

Check the wiring connections.

Check the horn button (CHECKING THE HORN BUTTON).

Check the horn (CHECKING THE HORN).

B. SOUNDS CONTINUOUSLY

Check the wiring connections.

Check the horn button (CHECKING THE HORN BUTTON).

CHECK DATA**CHECKING THE HORN**

Disconnect the horn and apply voltage to it directly with a 12 V battery.

Adjust with the adjuster, if necessary.



CHECKING THE HORN BUTTON

Disconnect the button connector.

Using a multimeter with the scale set to ohms, check the continuity between the contacts in the pressed and rest positions by testing the connections (MAIN WIRING DIAGRAM).

BRAKING LIGHTS CIRCUIT

Location of components see (LOCATION OF COMPONENTS).

WIRING DIAGRAM

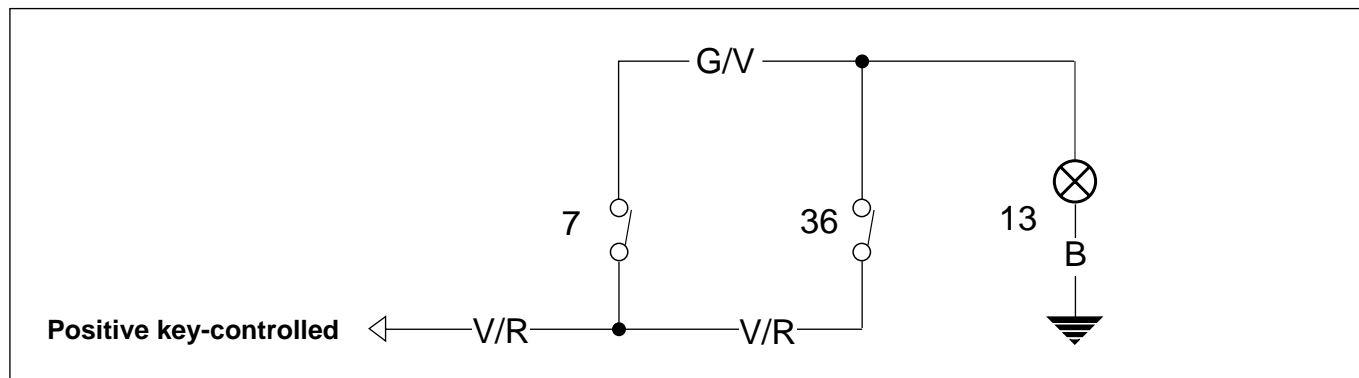

- 7) Brake light rear switch
- 13) Taillight (brake light bulb)
- 36) Brake light front switch

6

TECHNICAL DATA

Brake lights
bulb 12 V - 21 W

TROUBLESHOOTING

A. BRAKE LIGHT STAYS LIT CONTINUOUSLY

Check the taillight connections.

Check the brake light front switch (CHECKING THE BRAKE LIGHT FRONT AND REAR SWITCH).

Check the brake light rear switch (CHECKING THE BRAKE LIGHT FRONT AND REAR SWITCH).

B. BRAKE LIGHT DOESN'T SWITCH ON

Check the bulb and bulb holder.

Check the wiring connections.

Check the general power supply circuit.

Check the brake light front switch (CHECKING THE BRAKE LIGHT FRONT AND REAR SWITCH).

Check the brake light rear switch (CHECKING THE BRAKE LIGHT FRONT AND REAR SWITCH).

CHECK DATA**CHECKING THE BRAKE LIGHT FRONT AND REAR SWITCH****Brake light front switch:**

disconnect the 2-way connector.

Brake light rear switch:

lift up the cap and disconnect the terminals.

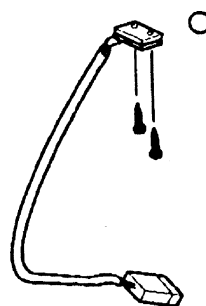

Operate the brake and test the resistance between the 2 wires on the connector, using a multimeter with the scale set to ohms:

Normal value with brake engaged: 0 Ω .

Normal value with brake not engaged: infinity.

LIGHT CIRCUIT

Location of components see (LOCATION OF COMPONENTS).

WIRING DIAGRAM

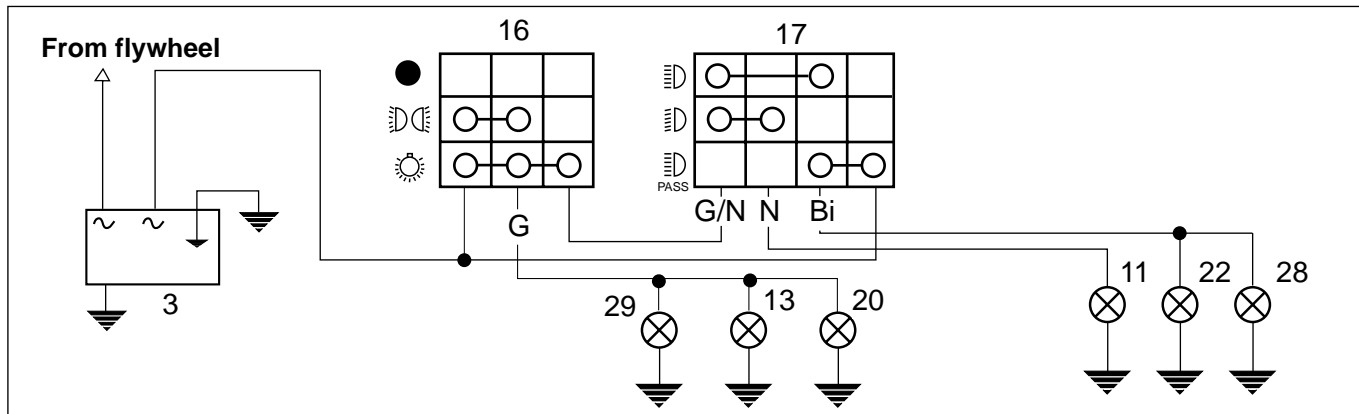

- 3) Regulator
- 11) Low beam light
- 13) Rear parking light
- 16) Right high/low beam selector
- 17) Left high/low beam selector
- 20) Dashboard light
- 22) High beam warning light
- 28) High beam light
- 29) Front parking light

TECHNICAL DATA

High and low beam light bulb	12 V - 35 W
Rear parking light bulb	12 V - 5 W - BAY 15d
Dashboard light bulb	12 V - 2 W W2.1x9.5 d all-glass type
High beam warning light bulb	12 V - 2 W W2.1x9.5 d all-glass type
Front parking light bulb	12 V - 5 W W2.1x9.5d all-glass type

LIGHT CIRCUIT ASD

Location of components see (LOCATION OF COMPONENTS).

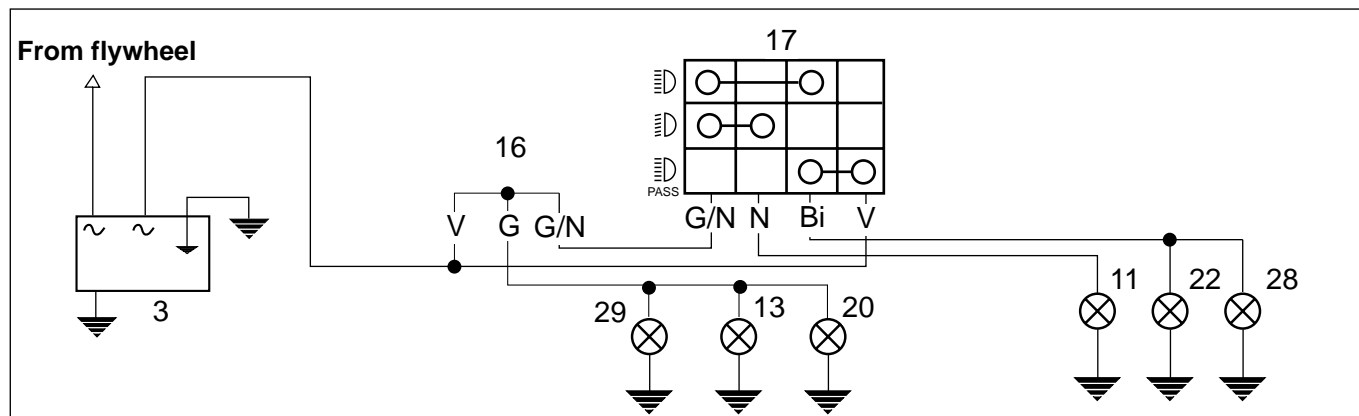
WIRING DIAGRAM

- 3) Regulator
- 11) Low beam light
- 13) Rear parking light
- 16) Right high/low beam selector
- 17) Left high/low beam selector
- 20) Dashboard light
- 22) High beam warning light
- 28) High beam light
- 29) Front parking light

TECHNICAL DATA

High and low beam light bulb	12 V - 35 W
Rear parking light bulb	12 V - 5 W - BAY 15d
Dashboard light bulb	12 V - 2 W W2.1x9.5 d all-glass type
High beam warning light bulb	12 V - 2 W W2.1x9.5 d all-glass type
Front parking light bulb	12 V - 5 W W2.1x9.5d all-glass type

TROUBLESHOOTING**A. A LIGHT DOESN'T WORK**

Check the bulb.

Check for voltage on the bulb holder terminals.

Check the wiring connections.

B. NONE OF THE LIGHTS WORK

Check the high/low beam selectors.

Check the voltage regulator (CHECKING THE VOLTAGE REGULATOR).

Check the generator (CHECKING THE GENERATOR).

6

C. BULBS BURN OUT FREQUENTLY

Check for excessive vibration on the lights and check that none of the lights are touching against parts of the motorcycle without flexible mountings.

Check the wiring connections.

Check the voltage regulator (CHECKING THE VOLTAGE REGULATOR).

WATER TEMPERATURE SENSOR**TROUBLESHOOTING****A. TEMPERATURE READING TOO LOW**

Check the connections.

Check that the green/red wire on the sensor is supplied with power.

Check the coolant thermistor (1).

Check the coolant temperature gauge (2).

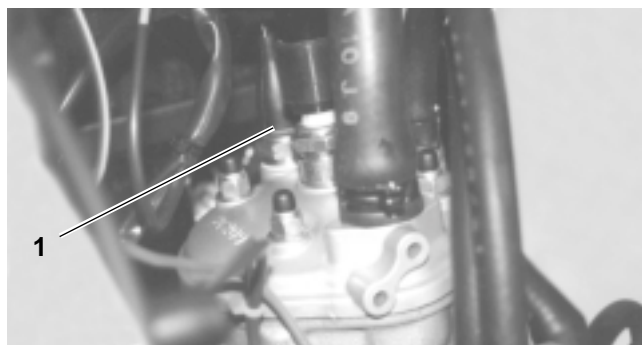
**B. TEMPERATURE READING TOO HIGH**

Check the cooling circuit.

Check the connections.

Check the coolant thermistor (1).

Check the coolant temperature gauge (2).

CHECK DATA**CHECKING THE WORKING STATE OF THE COOLANT TEMPERATURE GAUGE**

Raise up the petrol tank.

Disconnect terminal (B) (black/white wire) from the thermistor (3).

Connect a 130 Ω resistance (C).

Turn the ignition switch to position "O".

Check that the pointer (A) goes to the beginning of the red zone ("Max"), with a tolerance of $\pm 5^\circ$.

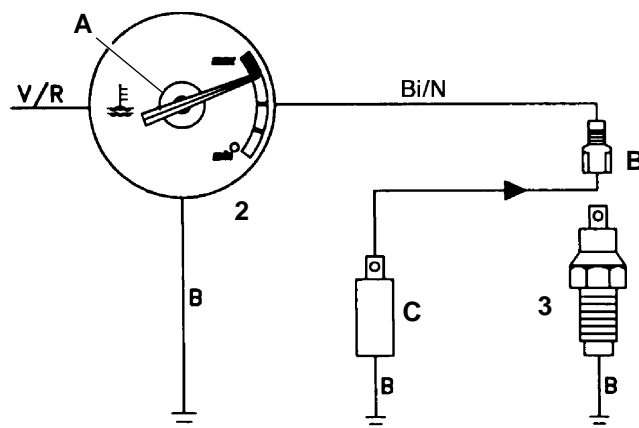
**CHECKING THE WORKING STATE OF THE THERMISTOR**

Drain the cooling system (DRAINING THE COOLING SYSTEM).

Raise up the petrol tank.

Disconnect terminal (B) (black/white wire) from the thermistor (1).

Remove the thermistor (1), (see ENGINE WORKSHOP MANUAL n°966 (I), n°967 (F), n°968 (D), n°969 (E), n°970 (UK), n°971 (USA)).

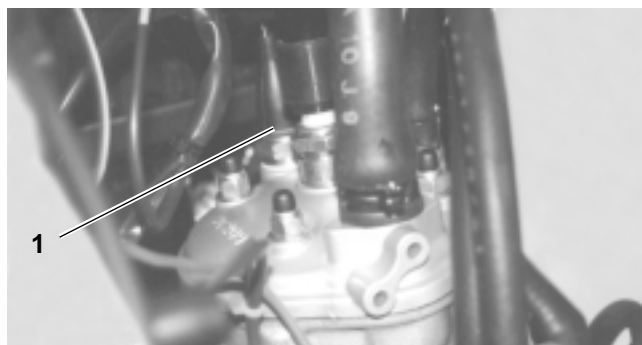

As illustrated in the figure, connect a multimeter (D) with the scale set to ohms to the thermistor (1). Immerse the thermistor in a receptacle (F) containing coolant. Immerse a thermometer (E) with a range of $0^{\circ} \pm 150^{\circ}\text{C}$ ($32^{\circ} \pm 302^{\circ}\text{C}$) in the same receptacle. Position the receptacle over a burner (G) and slowly heat the liquid. Check the temperature reading on the thermometer and the thermistor reading on the tester.

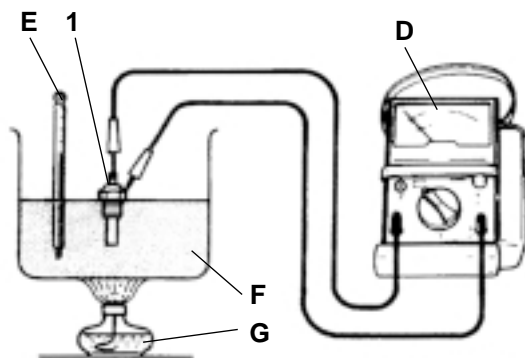

Check that the thermistor responds to the temperature as shown below:

Coolant temperature $^{\circ}\text{C}$ ($^{\circ}\text{F}$)	Standard values (Ω)
60° (140°)	approx. $510 \pm 10\%$
100° (212°)	approx. $130 \pm 10\%$

▲ WARNING

If the values do not change, or if they differ too much from those in the table, replace the thermistor with a new one.

6

ELECTRICAL CONNECTORS

To disconnect the two electrical connectors, proceed as follows:

Press the safety catches, if present.

▲ CAUTION

Do not pull on the wires to unplug the two connectors. This will destroy the wires.

Grip the two connectors and unplug them by pulling them apart.

If there is any dirt, rust, moisture, etc...., clean the inside of the connector thoroughly with a compressed air jet.

Make sure that the wires are properly clipped into the terminals inside the connectors.

NOTE The two connectors can only be plugged together in one way: make sure they are positioned correctly.

After plugging the two connectors together, make sure they are properly connected (if the connectors have safety catches you will hear the “click” sound).

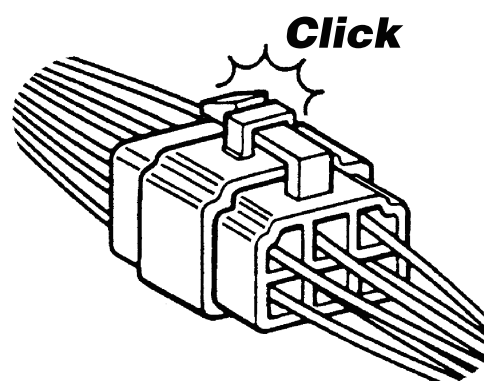

BULBS

Read carefully (MAINTENANCE).

▲ CAUTION

Risk of fire. Keep fuel and other flammable substances away from the electrical components. Before changing a bulb, turn the ignition switch to the "⊗" (OFF) position and wait a few minutes so that the bulb cools down. Change the bulb wearing clean gloves or using a clean and dry cloth. Do not leave fingerprints on the bulb, since these may cause its overheating and consequent breakage. If you touch the bulb with bare hands, remove any fingerprint with alcohol, in order to avoid any damage. TAKE CARE TO AVOID DAMAGING THE ELECTRICAL CABLES.

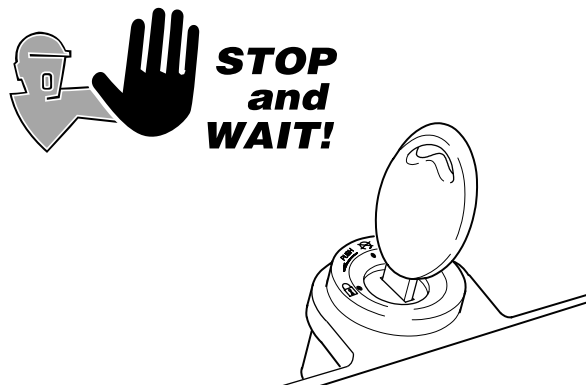

CHANGING THE HEADLIGHT BULBS

Read carefully (BULBS).

Position the motorcycle on the stand.

NOTE Before changing a bulb, check the fuse, see (CHANGING FUSES).

The headlight contains:

- one high beam bulb (1) (right side);
- one parking light bulb (2) (lower side);
- one low beam bulb (3) (left side).

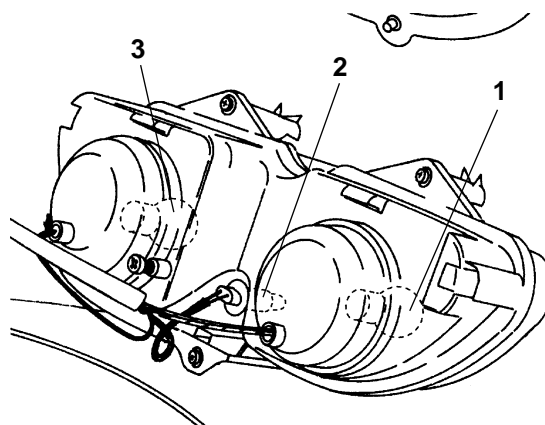

The high and low beam bulbs are identical.

If the low beam is burned out and no spare bulb is available, it is possible to substitute the high beam bulb for the low beam bulb.

This should only be done to make it possible to ride a short distance at night to a shop where a new bulb can be obtained or home.

CHANGING PARKING LIGHT BULB

▲ CAUTION

While removing a bulb socket, do not pull on the wires.

Working from the rear side of the front part of the fairing, grasp the bulb socket (4), pull it and remove it from its seat.

Remove the parking light bulb (5) and replace it with an identical bulb.

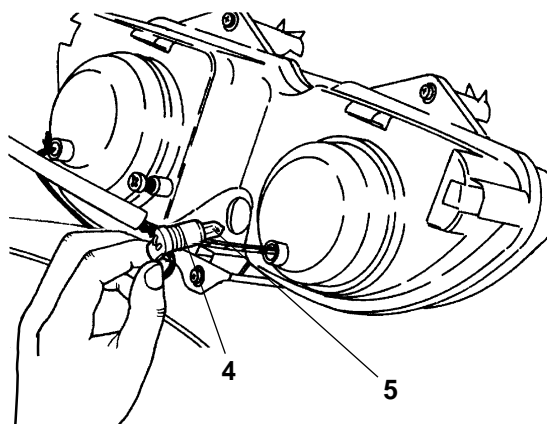

CHANGING HIGH BEAM BULB

NOTE Remove the bulb sockets one by one in such a way as to avoid replacing them incorrectly during reassembly.

If the bulb sockets must all be removed at the same time, take great care to reassemble them in the proper position.

Working from the rear right side of the front part of the fairing, pull back the rubber boot (1) with your fingers. Rotate the bulb socket (2) counterclockwise and remove it.

Push the bulb (3) toward the back of the socket lightly, and rotate it counterclockwise. Remove the bulb from the seat.

NOTE Be sure to maintain the same orientation as the old bulb when you install the new bulb.

Do not force the bulb, it will go easily if it is properly oriented.

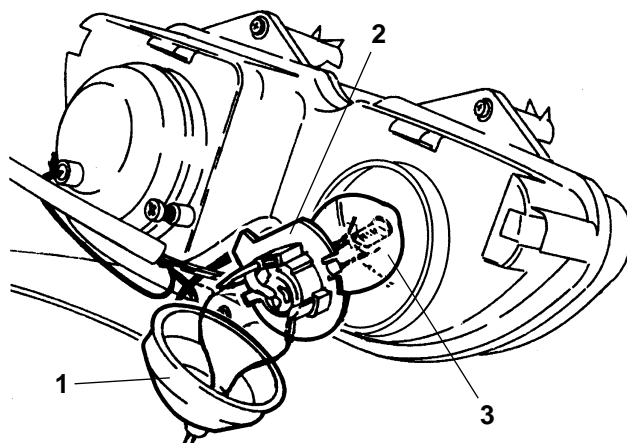

6

CHANGING LOW BEAM BULB

NOTE Remove the bulb sockets one by one in such a way as to avoid replacing them incorrectly during reassembly.

If the bulb sockets must all be removed at the same time, take great care to reassemble them in the proper position.

Working from the rear left side of the front part of the fairing, pull back the rubber boot (4) with your fingers. Rotate the bulb socket (5) counterclockwise and remove it.

Push the bulb (6) toward the back of the socket lightly, and rotate it counterclockwise. Remove the bulb from the seat.

NOTE Be sure to maintain the same orientation as the old bulb when you install the new bulb.

Do not try to force the bulb, it will go easily if it is properly oriented.

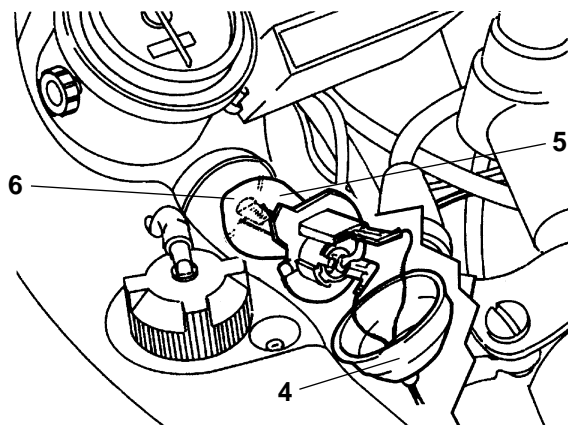

CHANGING THE FRONT AND REAR TURN SIGNAL BULBS

Read carefully (BULBS).

NOTE Before changing a bulb, check the fuse, see (CHANGING FUSES).

Position the motorcycle on the stand.

Unscrew and remove the screw (1).

NOTE While removing the lens, use extra care to be sure that you do not break the key.

Remove the lens (2).

NOTE Upon reassembly, position the lens correctly in its seat.

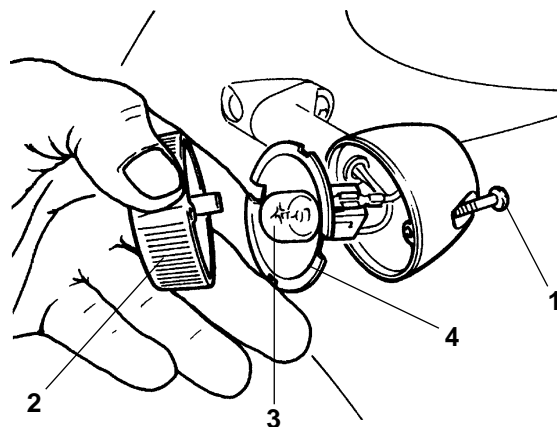

▲ CAUTION

Tighten the screw (1) moderately and with care to avoid damaging the lens.

Push the bulb (3) in slightly and rotate it counterclockwise.

Extract the bulb from its seat.

NOTE Insert the bulb in the bulb socket, carefully aligning the two bulb pins with their guides in the socket.

Correctly install a new bulb of the same type.

NOTE If the bulb socket (4) has fallen out of its seat, replace it correctly, ensuring that the slot in the reflector aligns with the screw hole in the body of the turn signal lamp.

CHANGING THE REAR LIGHT BULB

Read carefully (BULBS).

NOTE Before changing a bulb, check the fuse, see (CHANGING FUSES), also check the operation of the stoplight switches, see (CHECKING THE SWITCHES).

Position the motorcycle on the stand.

Unscrew and remove the two screws (5).

Remove the lens (6).

NOTE Upon reassembly, make sure that the lens seats properly.

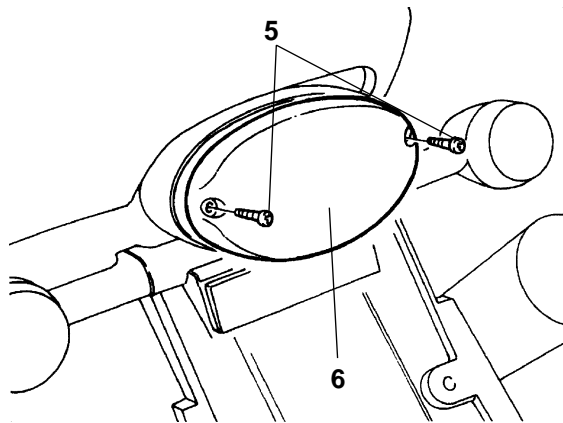

▲ CAUTION

Upon reassembly, do not overtighten the two screws (5). Overtightening will crack the lens.

To remove the bulb (7), push the bulb slightly forward and rotate it counterclockwise.

Pull it from its seat.

NOTE Ensure that the orientation of your replacement bulb is identical to that of the original bulb.

Do not try to force the bulb (7), it will fit easily if it is properly oriented.

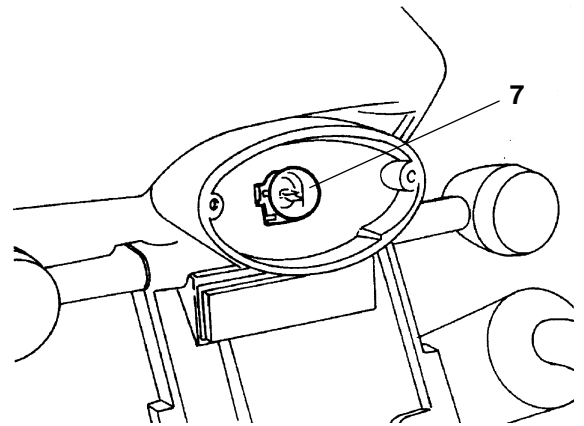

ADJUSTING THE HEADLIGHT BEAM VERTICALLY

NOTE The procedure described here is in compliance with the Italian standard that establishes the maximum height of the headlight beam. For motorcycles used in other countries, you must conform with the local regulations.

To quickly check the correct direction of the beam, place the motorcycle on flat ground, 10 m (32.81 ft) away from a wall.

Turn on the low beam, sit on the motorcycle and make sure that the beam projected on the wall is slightly under the horizontal line of the headlight (about 9/10th of the total height).

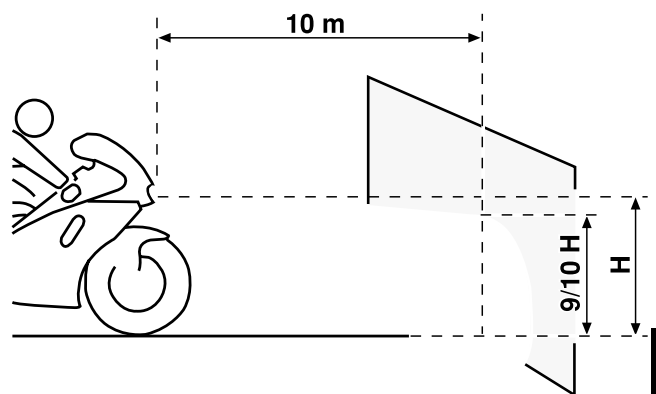

6

To adjust the headlight beam:

Working from the left rear side of the front part of the fairing, adjust the screw (1) with a short Philips screwdriver.

By **SCREWING IT** clockwise, you set the beam higher.

By **UNSCREWING IT** counterclockwise, you set the beam lower.

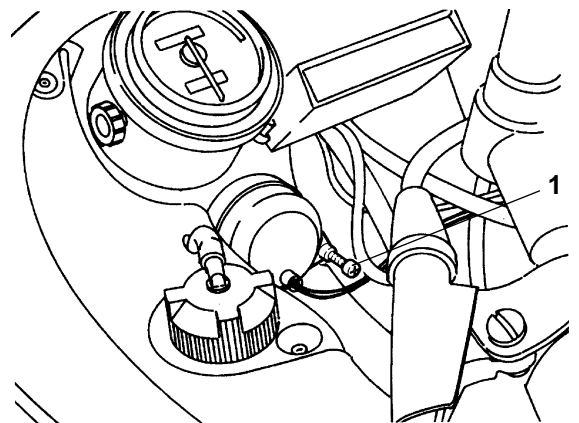

ADJUSTING THE HEADLIGHT BEAM HORIZONTALLY

NOTE The terms “right” and “left” are referred to the rider seated on the motorcycle in the normal riding position.

It is possible to adjust the horizontal position both to the right and to the left.

The adjustment is carried out using shims and adjusting screws which are supplied as a kit. They will be found in the glove box/ tool kit compartment.

To adjust the beam:

Remove the front part of the fairing, see (REMOVING THE FRONT PART OF THE FAIRING).

Unscrew and remove the screw (1).

Unscrew and remove the screws (2).

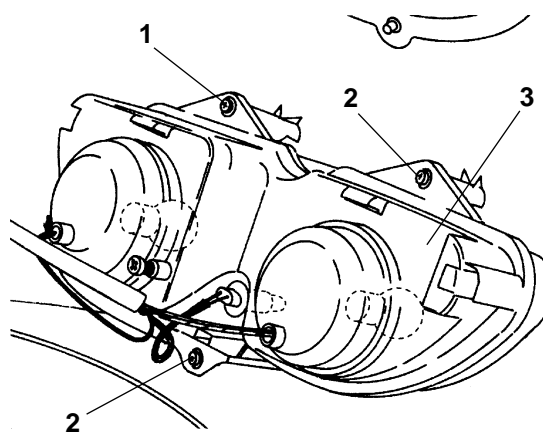

▲ CAUTION

Handle with care.

Take care not to damage the electric wires.

Loosen the headlight (3).

There are four groups of shims, for four different degrees of adjustment.

Each shim is marked with the type identification code (for example: UPPER) and with the group number (for example: 3°) (see table below).

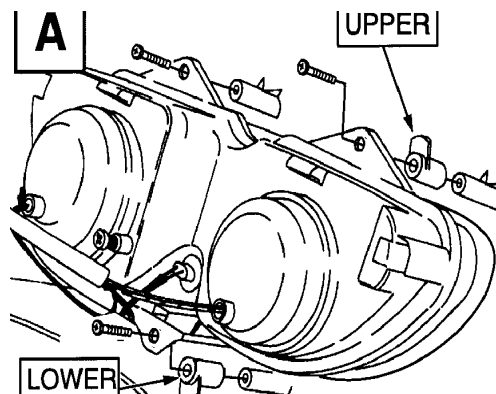

Adjustment degree				
Group	1°	2°	3°	4°
Shim	UPPER 1	UPPER 2	UPPER 3	UPPER 4
Screw	4.2 x 20	4.2 x 20	4.2 x 20	4.2 x 20
Shim	LOWER 1	LOWER 2	LOWER 3	LOWER 4
Screw	4.2 x 20	4.2 x 25	4.2 x 25	4.2 x 30

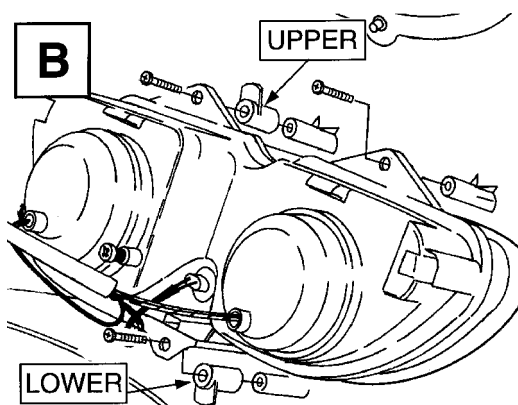

Depending on the beam adjustment to be carried out, select:
the group necessary for the adjustment;
the direction (to the right or to the left).

NOTE Do not mix up screws and shims. Use them only in the proper sets.

Insert the shims in the headlight screw seats as indicated in figures A and B:
rightwards (figure A);
leftwards (figure B).

Position the headlight (3) in its seat.
Tighten the lower left screw (1).

NOTE Replace the screws (2) with the specific screws corresponding to each shim.

Keep the screws (2) and shims that you do not use together in the tool kit, in case further adjustment is required.

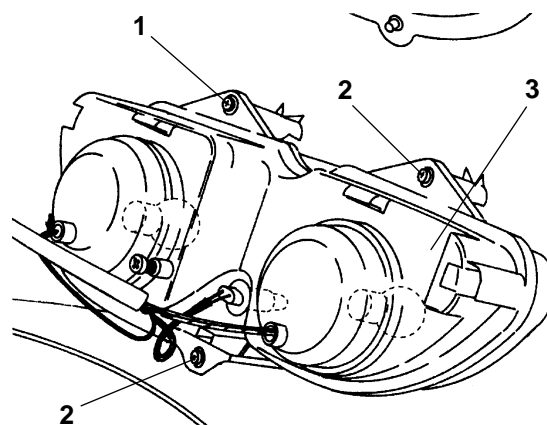

6

Tighten the two screws specific for each shim.
Tighten the remaining three screws.

Tighten the three screws.

Replace the front part of the fairing, see (REMOVING THE FRONT PART OF THE FAIRING).

Make sure that the horizontal adjustment of the headlight beam is correct.

Make sure that the vertical adjustment of the headlight beam is correct, see (ADJUSTING THE HEADLIGHT BEAM VERTICALLY).

CHANGE FUSES

Read carefully (SERVICING SCHEDULE).

⚠ CAUTION

Do not repair faulty fuses.
Use only recommended fuses. Using fuses of an improper capacity can cause damage to the electrical system or an electrical fire, which could result in total destruction of your motorcycle as well as injury to you.

NOTE If a fuse blows frequently, there probably is a short circuit or an overload in the electrical system. If this occurs, take the motorcycle to your Local aprilia Dealer.

If an electric component does not work or works irregularly, or if the motorcycle fails to start, it is necessary to check the fuse (1).

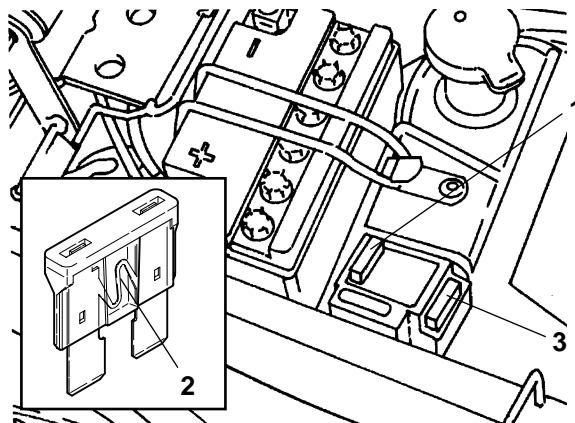

To check the fuse:

Turn the ignition switch (2) in the "⊗" (OFF) position. Remove the rider saddle (REMOVING THE RIDER SADDLE).

Remove the fuse (1) and inspect the filament (2).

If it is open, the fuse must be replaced.

Replace the blown fuse with the spare fuse (3), or with a new fuse having the same amperage rating.

NOTE If you use the spare fuse (3), replace it as soon as convenient.

FUSE CIRCUIT**A 7.5 amp fuse protects**

all of the electrical loads except the lighting circuit, which is fed with alternating current directly from the alternator.

CHECKING THE SWITCHES

Read carefully (**SERVICING SCHEDULE**).

The motorcycle is equipped with three switches:
Stoptight switch on the rear brake pedal (1);

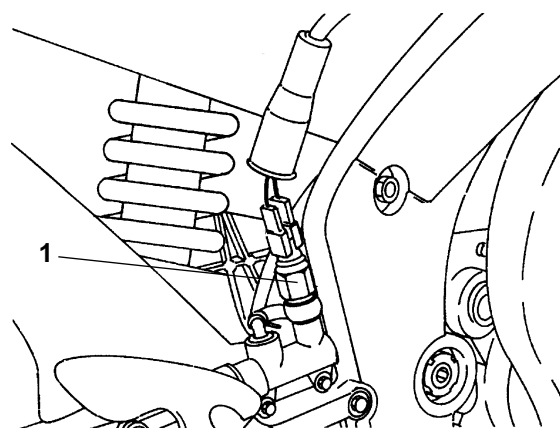

Stoptight switch on the front brake lever (2);

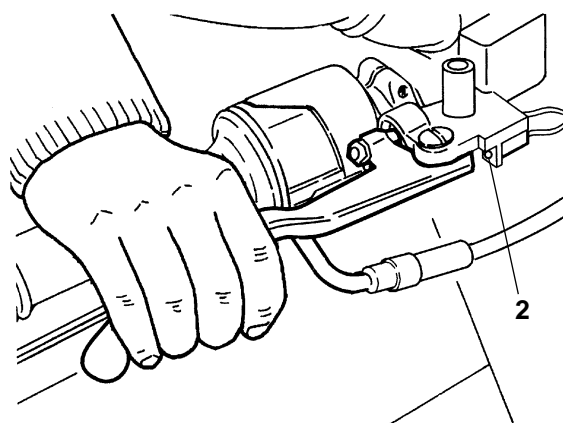

Safety switch on the side stand (3).

Make sure that there is no dirt or mud on the switch.
The switch pin must move freely and without interference,
returning automatically to its unapplied position.

Check that the wires are properly connected.

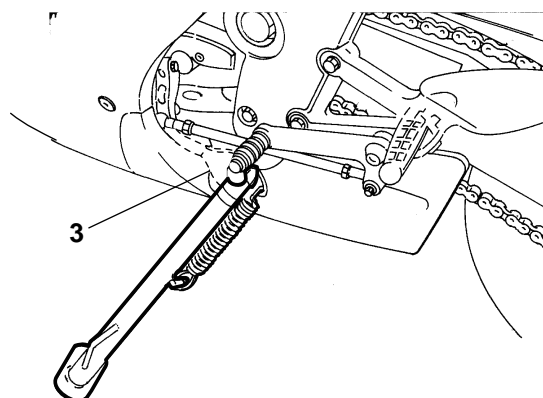

Check the spring (4); it must not be damaged, worn
or stretched.

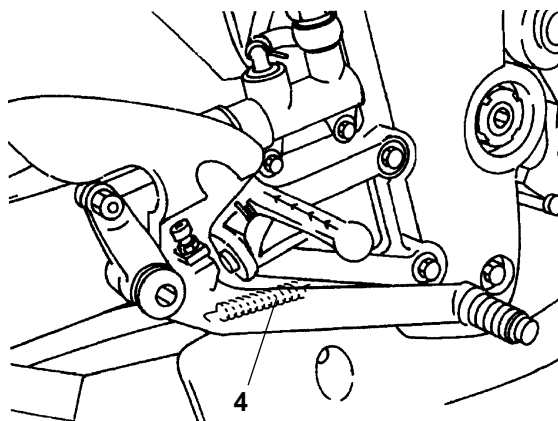

NOTES

Body work

7

APPLYING THE TRANSFERS

When removing parts of the frame:

⚠ CAUTION

Handle plastic and painted parts carefully so as not to scratch or damage them. Perform the work with the utmost care. Do not damage the tabs and/or the slots into which they are inserted.

To apply the transfers, carefully follow the instructions below.

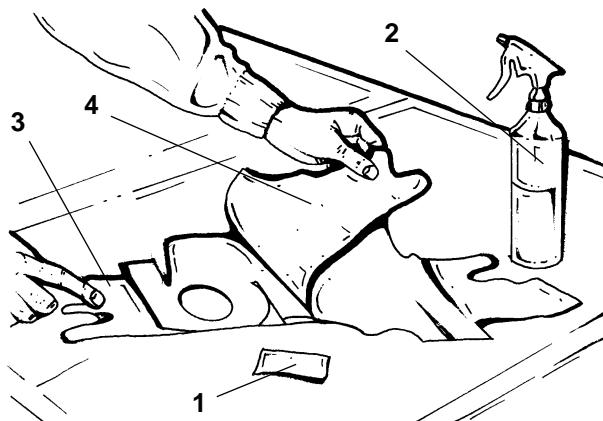

The following tools are recommended:
medium-stiff (1) squeegee;

NOTE Generally, soft, squeegee-type spatulas do not remove enough water from under the transfer.

sponge or spray (2) with water.

NOTE Add detergent (1-3%) to the water and shake or stir to make it foamy.

To apply, proceed as follows:

Position the transfer (3), face down, on a work surface. Keeping the transfer spread flat on the work surface, completely remove the backing paper (4).

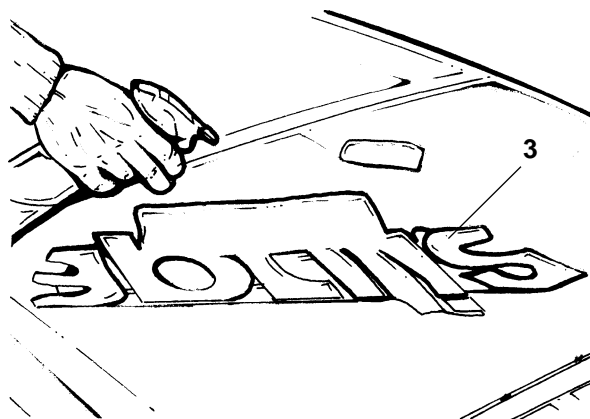

NOTE You are advised to use a sprayer (2).

If you use a sponge, sponge the surface lightly, to avoid damaging the adhesive.

Wet the adhesive surface with soapy water.

Apply the transfer (3) to the surface to be decorated, moving it to the correct position.

NOTE Keep smoothing the transfer with the squeegee with constant movement from the center outwards.

Using the squeegee (1), pressing lightly, smooth away all excess soap and water from over and under the transfer.

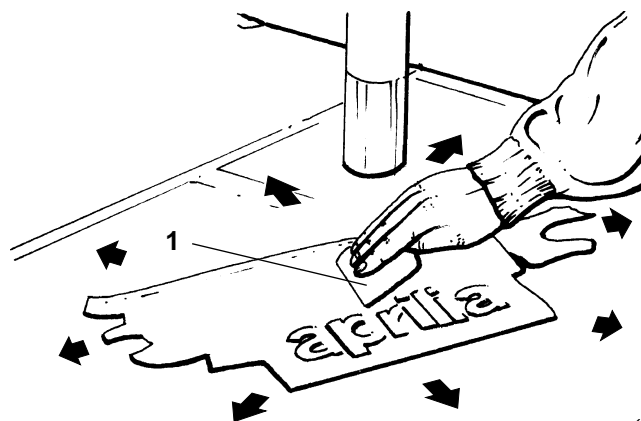

NOTE Do not lift up the corners and/or sides of the transfer.

Dry the transfer by wiping it from the center outward with a soft cloth.

Go over the transfer again with the squeegee, pressing down as firmly and evenly as possible in the movements.

Smooth from the center outwards, making sure that the whole transfer is properly stuck down, especially the corners and sides.

NOTE The application tape (1), if present, must be removed 20-30 minutes after the application of the transfer.

The tape is used in the application of logos and letters, making it easier to position them correctly on the surface and helping the glue to set more firmly. Peel off the application tape (5) from the transfer surface.

Go over the transfer again with the squeegee to make sure it has adhered properly, especially the edges and corners.

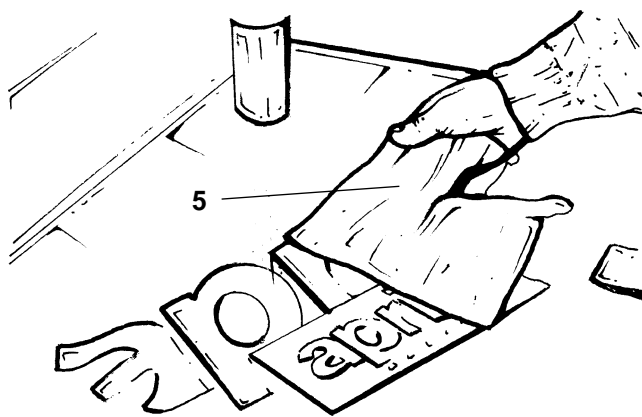

NOTE With the wet application method, the transfer takes 48 hours to set properly.

Make sure there are no air bubbles under the surface after removing the application tape.

If there are any air bubbles, use a sharp pin or cutter (6) to puncture the edge (7) of the air bubble.

Using the squeegee (1) and starting from the opposite side to the puncture, smooth down the bubble and force the air out.

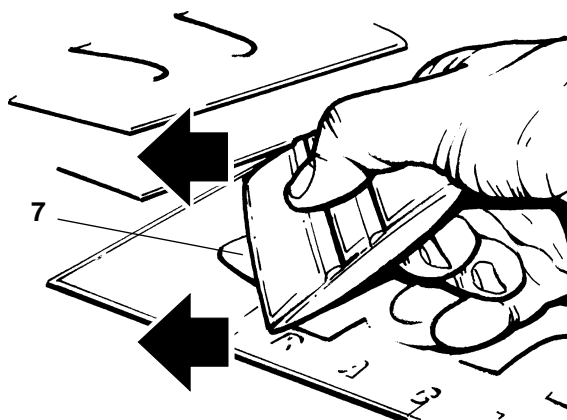
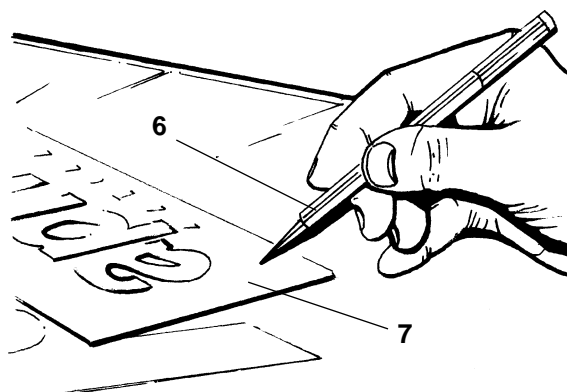

7

REMOVING THE RIDER SADDLE

Read carefully (SERVICING SCHEDULE).

Position the motorcycle on the stand.
 Insert the key (1) in the lock (2).
 Rotate the key (1) clockwise.
 Raise and remove the saddle (3).
 Remove the flap (4).

Upon reassembly:

Position the flap (4) correctly.
 Insert the rear tangs (5) of the saddle in the appropriate seats (see figure).
 Lower the saddle and insert the two pins (6) in the matching seats.
 Turn the key (1) counterclockwise, locking the saddle.

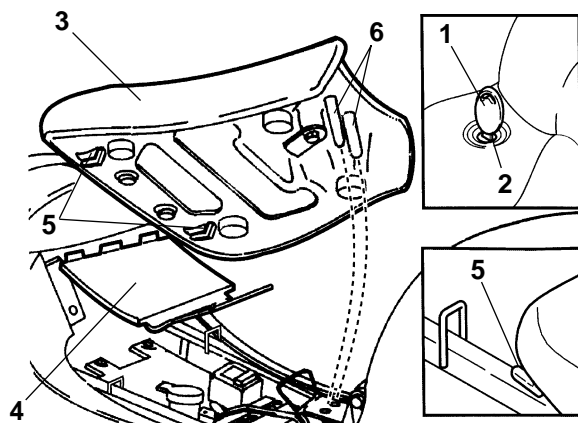

⚠ WARNING

Before riding, make sure that the saddle (3) is properly positioned and locked: risk of serious injuries or even death.

REMOVING THE SADDLE LOCK

Unscrew and remove the screw (7).
 From below, remove the washer (8), saddle locking plate (9), nut (10) and serrated washer (11).
 Remove the (12) lock (13) and ring (14) from above the saddle.
 Lift up and remove the saddle (12).

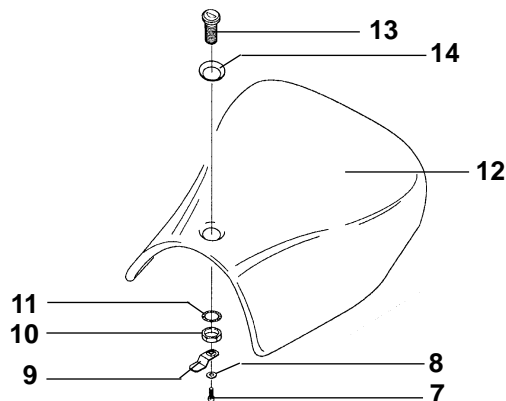

REMOVING THE PASSENGER SADDLE

Remove the rear fairing (REMOVING THE REAR FAIRING).
 Stand the rear fairing and saddle on a flat surface.

⚠ WARNING

Be careful not to scratch the rear fairing and decal.

Slacken and remove the 7 screws (15) that secure the Passenger saddle (16) to the rear fairing (17).
 Separate the passenger saddle (16) from the rear fairing (17).

Torque setting for screws (1):
2 Nm (0.2 kgm) [1.5 Ft-lb].

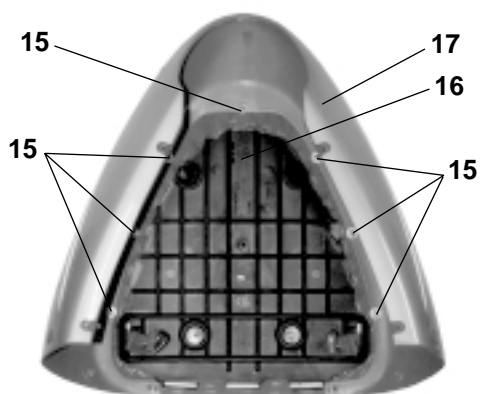

REMOVING THE SIDE FAIRINGS

Read carefully (SERVICING SCHEDULE).

▲ WARNING

Before carrying out the following operations, let the engine and the exhaust silencer cool down until they reach room temperature, in order to avoid burns.

Position the motorcycle on the stand.

Unscrew and remove the four screws (1).

Unscrew and remove the two lower screws (2).

For the left fairing: unscrew and remove the two rear screws (3).

For the right fairing: unscrew and remove the rear screw (4).

Unscrew and remove the four screws (5).

▲ CAUTION

Handle the plastic and painted components with care and avoid scraping or damaging them. Be careful not to damage the electric cables.

Disconnect the two electric terminals (6) of the direction indicator.

Remove the side fairing (7).

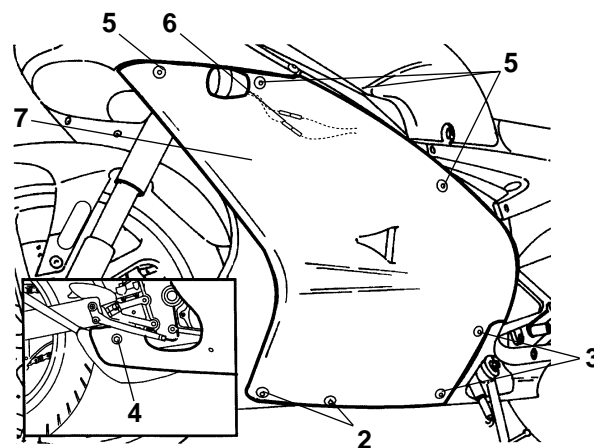
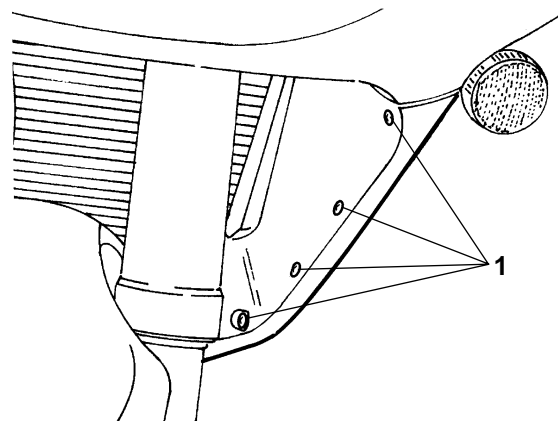

REMOVING THE FUEL TANK

Read carefully (FUEL) and (SERVICING SCHEDULE).

▲ WARNING

Risk of fire.

Wait until the engine and the exhaust silencer have completely cooled down.

Fuel vapors are poisonous.

Make sure that the room in which you are working is properly ventilated.

Do not inhale fuel vapours.

Do not smoke and do not use naked flames.

DISPOSE OF UNWANTED FUEL PROPERLY.

Move the fuel valve lever (1) to the "OFF" position.

Remove the rider saddle, (REMOVING THE RIDER SADDLE).

Remove the screw (2) and bushing.

Drain the fuel tank completely, (DRAINING THE FUEL TANK).

Position an absorbent cloth (3) on the front support of the seat (4).

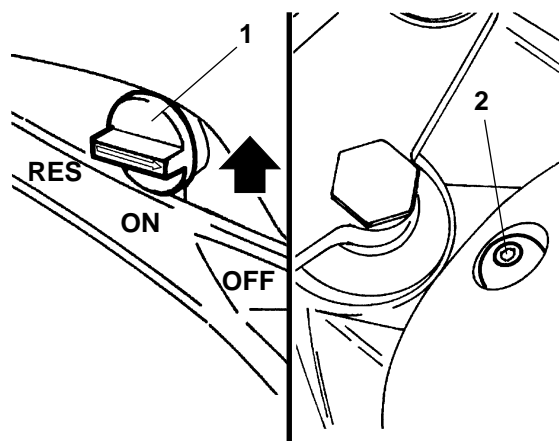

▲ CAUTION

Handle with care.

While removing the fuel tank (5), DO NOT force the fuel line (6).

Grasp the front part of the fuel tank (5) and lift it slightly.

Using a pair of pliers, release the clamp (7).

▲ CAUTION

Upon reassembly, be sure that the fuel line (6) and clamp (7) are properly installed.

Remove the fuel line (6) from the fuel valve (8).

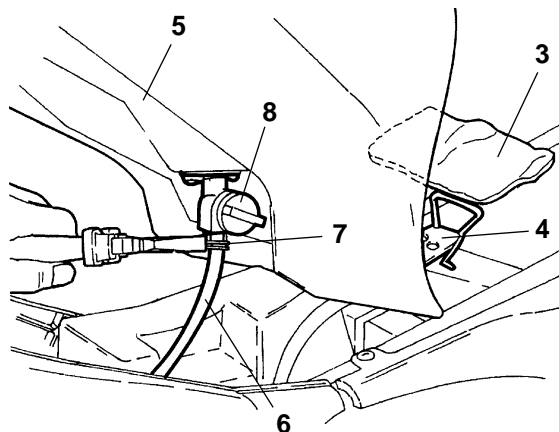

▲ WARNING

Danger! Some fuel may spill.

Plug the free end of the fuel line (6) and attach it to the motorcycle with a wire or tape in the vertical position.

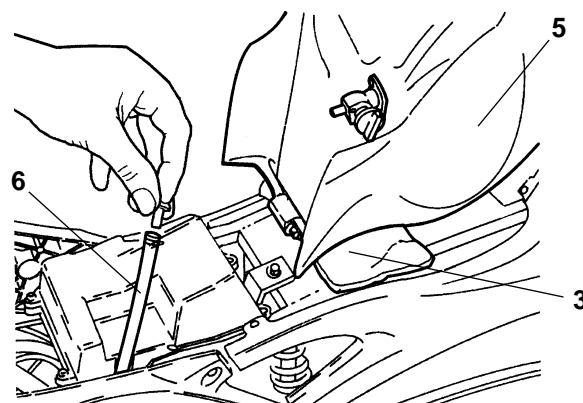

Replace the tank in its working position.
Loosen and remove the nut (9) that holds the bolt (10).
After removing the nut (9), withdraw the bolt (10) from its hole, where it fixes the tank to the frame.
Take off the washer (11).

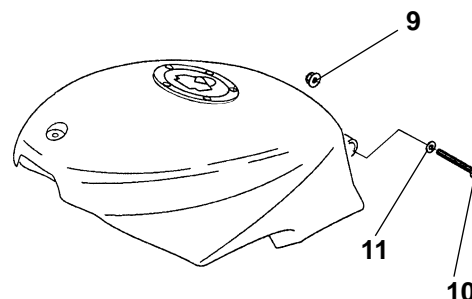

EMPTYING THE FUEL TANK

Read carefully (FUEL).

▲ CAUTION

Fire hazard.

Wait until the engine and exhaust muffler cool down completely.

Fuel vapors can damage your health.

Before proceeding, make sure there is a suitable air exchange in the room where you are working.

Do not inhale fuel vapors.

Do not smoke or use naked flames.

DO NOT DISPOSE OF FUEL IN DRAINS, WATER COURSES OR THE SOIL.

▲ WARNING

The use of open flames is forbidden for any type of operation. Before commencing any service or inspection operation on the vehicle, switch off the engine and remove the key, wait until the engine and the exhaust system have cooled down and, if possible, raise the vehicle with the suitable equipment onto firm flat ground.

In order to avoid burns, be careful not to touch any parts of the engine or exhaust systems which have not cooled down completely.

▲ WARNING

The exhaust fumes contain carbon monoxide, a poisonous gas that can cause loss of consciousness and even death. Work in a well-ventilated area.

Keep cigarettes, flames or sparks away from the work area and from the place where gasoline is stored.

KEEP GASOLINE AWAY FROM CHILDREN. DO NOT DISPOSE OF FUEL IN THE ENVIRONMENT.

Position the motorcycle on the stand.

Stop the engine and wait for it to cool down.

Get a container, big enough to hold the quantity of fuel remaining in the tank (1), and place it on the ground to the left of the motorcycle.

Remove the fuel valve (2) and proceed with emptying the tank.

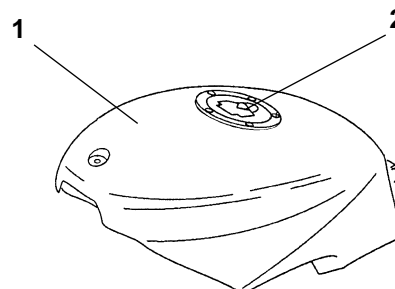

▲ CAUTION

After emptying the tank, reconnect the fuel valve.

REMOVING THE AIR BOX

Read carefully (SERVICING SCHEDULE).

Remove the fuel tank (REMOVING THE FUEL TANK).
Unscrew the screw (1) to loosen the clamp (2) on the intake hose leading to the carburetor.

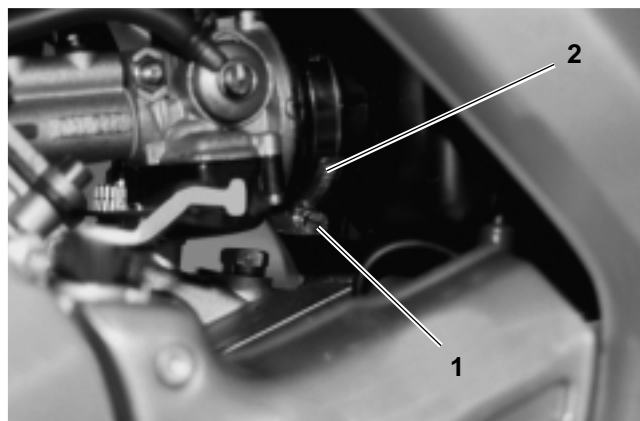

Unscrew and remove the screws (3) that secure the air box (4) to the frame.

Torque setting for screws (3):
5 Nm (0.5 kgm) [3.7 Ft-lb].

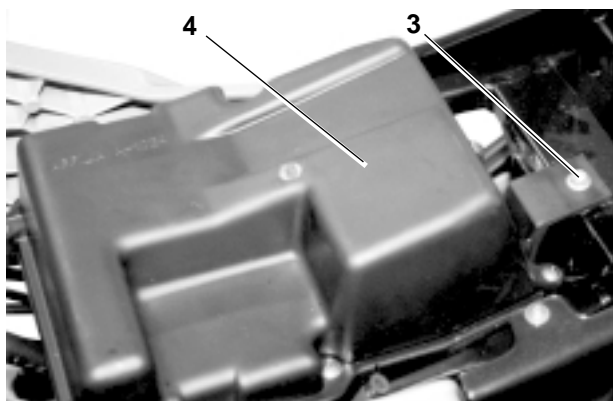

▲ CAUTION

Proceed with great care when removing the air box.

Lift up the rear end of the air box to withdraw it from the carburetor and air box support pin (5).

▲ WARNING

Plug the openings with a clean cloth, to prevent foreign bodies getting into the intake tubes.

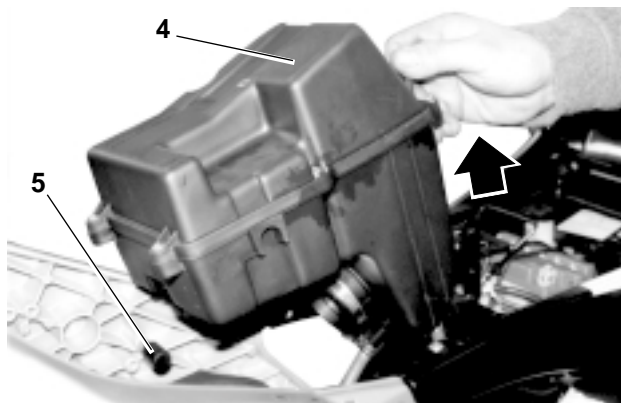

When refitting, position the air box on the support pins (5), then insert the intake hose into the carburetor, secure the box with the screw (3) and tighten the clamp (2) on the carburetor.

REMOVING THE LEFT HANDLEBAR HANDGRIP

Read carefully (PRECAUTIONS AND GENERAL INFORMATION).

Position the motorcycle on the stand.

Switch the ignition key to the "⊗" position.

Hold the counterweight (1) while loosening and removing the screw (2).

Remove the counterweight (1).

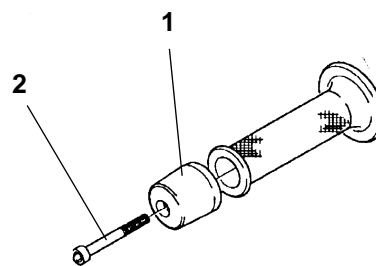

Insert the point of a compressed air gun between the handgrip (3) and the handlebar (4).

Blow in air while moving the point of the gun in a clockwise direction, gripping and removing the handgrip (3) with the other hand at the same time.

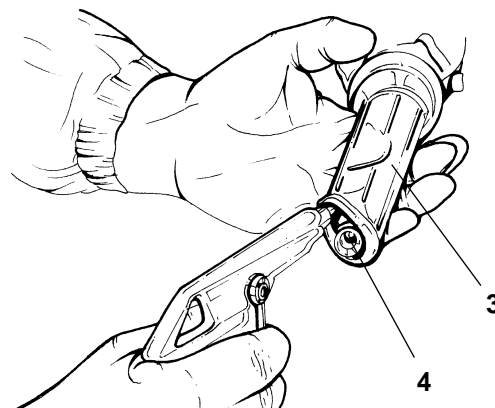

REMOVING THE LEFT HANDLEBAR ELECTRICAL CONTROLS

Read carefully (PRECAUTIONS AND GENERAL INFORMATION).

Position the motorcycle on the stand.

Switch the ignition key to the "⊗" position.

Unscrew the two screws (5) that secure the two half shells underneath.

Divide the two half shells.

Free the wiring from the clamps that fix it to the frame.

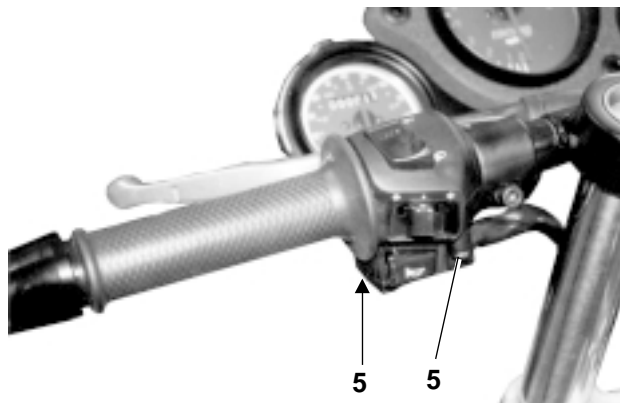

NOTE Prepare the same number of new clamps for refitting.

Disconnect the left high/low beam selector connector.

▲ WARNING

When refitting, make sure the connector is plugged in properly.

Remove the two half shells (6-7).

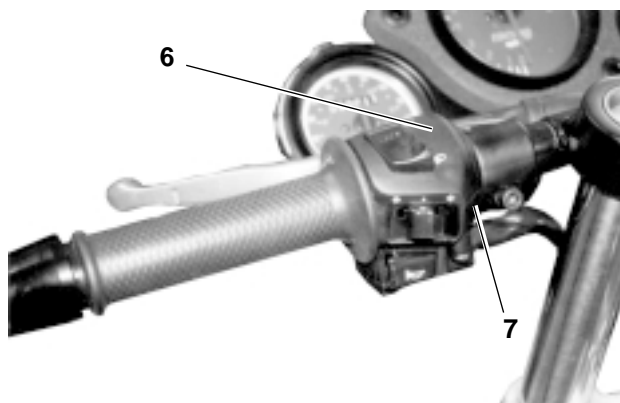

REMOVING THE CLUTCH CONTROL

Read carefully (PRECAUTIONS AND GENERAL INFORMATION).

Position the motorcycle on the stand.

Switch the ignition key to the "⊗" position.

Slide back the boot (1).

Loosen the nut (2) by twisting it until it butts up against the adjuster (3).

Line up the slots on the nut (2) and adjuster (3) with the slot (4) on the clutch lever bolt (5).

Pull the clutch cable (6) out and withdraw it from its housing on the clutch lever (7).

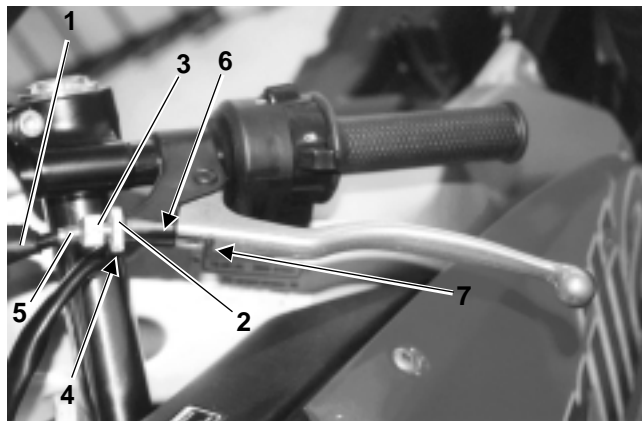

Loosen and remove the screw (8).

**Torque setting for screw (8):
12 Nm (1.2 kgm) [8.8 Ft-lb].**

Remove the clutch control (9).

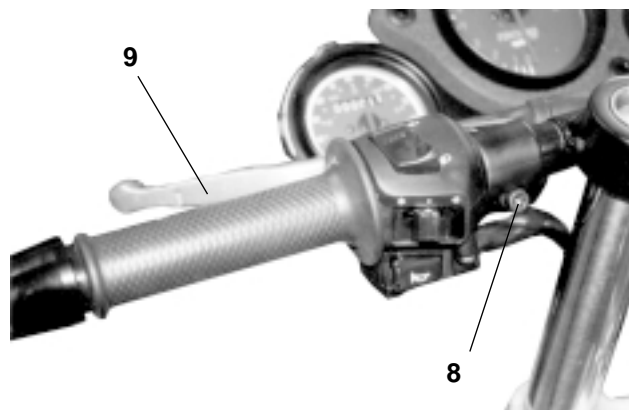

REMOVING THE THROTTLE CONTROL

Read carefully (PRECAUTIONS AND GENERAL INFORMATION).

Position the motorcycle on the stand.

Switch the ignition key to the "⊗" position.

Hold the counterweight (1) while loosening and removing the screw (2).

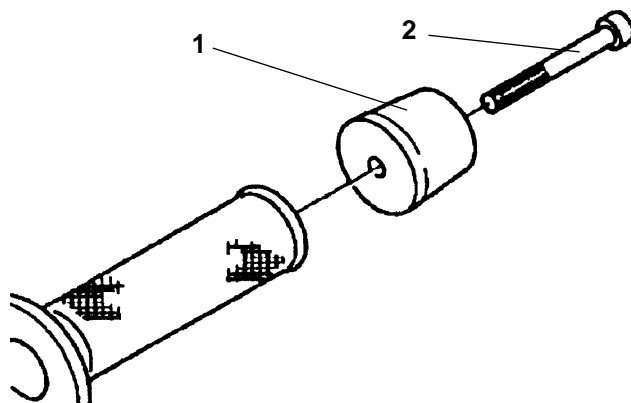

Unscrew and remove the two screws (3).

Torque setting for screws (3):
2 Nm (0.2 kgm) [1.5 Ft-lb].

Remove the upper half shell (4) from the right high/low beam selector (5).

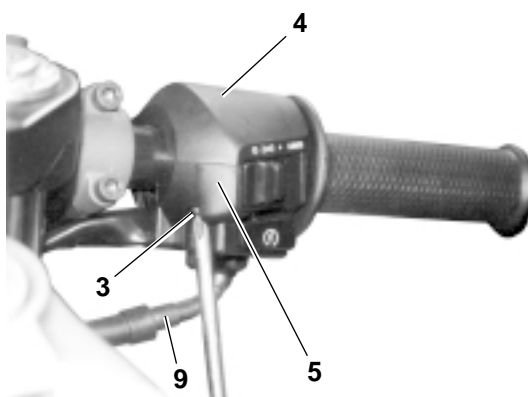

Remove the fuel tank (REMOVING THE FUEL TANK). Unscrew and remove the screws (6) on the carburetor valve cover.

Torque setting for screws (6):
2 Nm (0.2 kgm) [1.5 Ft-lb].

Withdraw the throttle control cable (7) from the throttle valve.

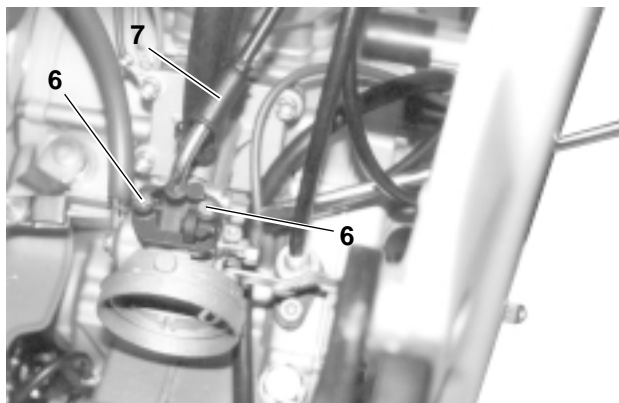

Disconnect the oil pump control cable (8).

Disconnect the throttle control cable and the oil pump control cable from inside the high/low beam selector (5).

Withdraw the throttle control (9).

▲ WARNING

When refitting, make sure that the two throttle control cables are in good condition and fitted properly.

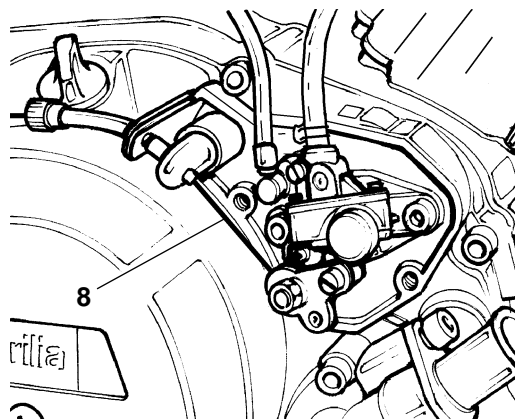

REMOVING THE RIGHT HANDLEBAR ELECTRICAL CONTROLS

Read carefully (PRECAUTIONS AND GENERAL INFORMATION).

Position the motorcycle on the stand.

Switch the ignition key to the "⊗" position.

The only operation required is to disconnect the throttle cable (1) from the block.

Free the wiring from the clamps that fix it to the frame.

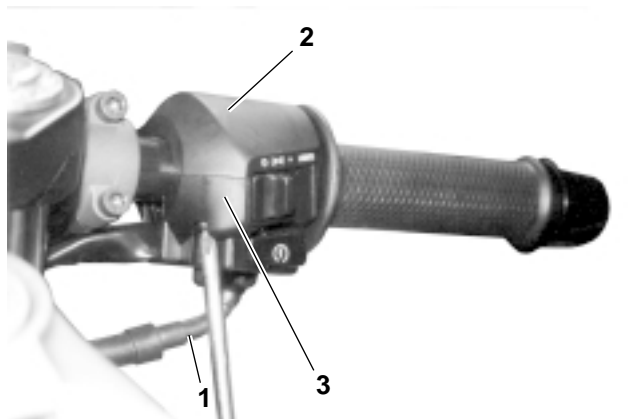

NOTE Prepare the same number of new clamps for refitting.

Disconnect the electrical connector on the right high/low beam selector.

Remove the two half shells (2-3).

Make sure the connector is plugged in properly when refitting.

REMOVING THE STOP SWITCH

Read carefully (PRECAUTIONS AND GENERAL INFORMATION).

Position the motorcycle on the stand.

Switch the ignition key to the "⊗" position.

Loosen and remove the 2 screws (4).

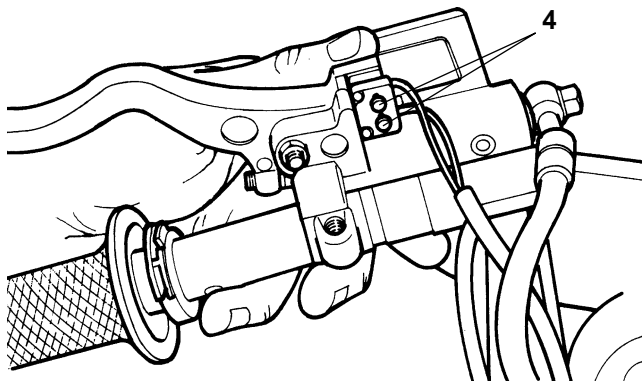

▲ CAUTION

Before removing the stop light switch, put your hand under it to catch the ball (6) as it falls.

Remove the stop switch (5) and catch the ball (6), unplugging the switch from the electrical connection.

When refitting, make sure the electrical connection is plugged in properly.

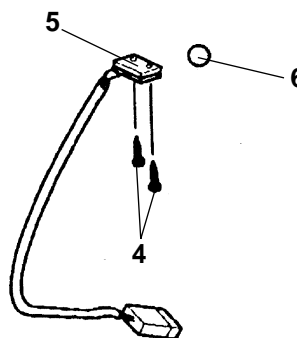

REMOVING THE FRONT BRAKE CONTROL

Read carefully (PRECAUTIONS AND GENERAL INFORMATION).

Position the motorcycle on the stand.

Switch the ignition key to the "⊗" position.

Unscrew and remove the 2 screws (1) that secure the front brake control (2).

Torque setting for screws (1):
12 Nm (1.2 kgm) [8.8 Ft-lb].

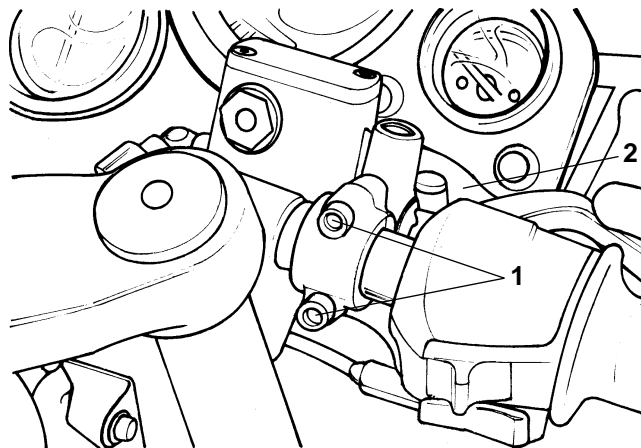

Loosen and remove the screw (3) that secures the tube guide clamp (4) on the fork bottom plate, to free the brake fluid tube (5).

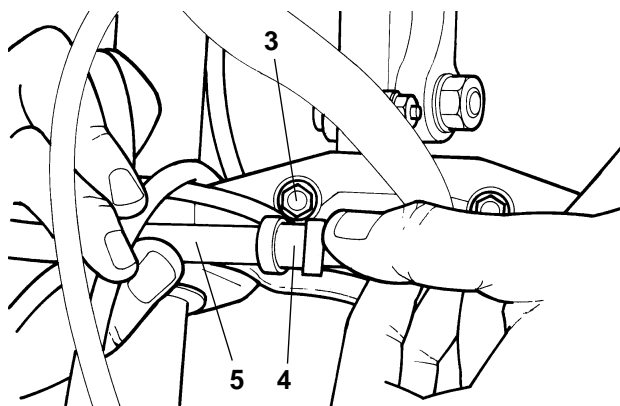

Torque setting for brake caliper screws (6):
22 Nm (2.2 kgm) [16.2 Ft-lb].

Unscrew and remove the two screws (6) that secure the front brake caliper (7).

Withdraw the disc from the brake caliper (7), leaving it connected to the tube (8).

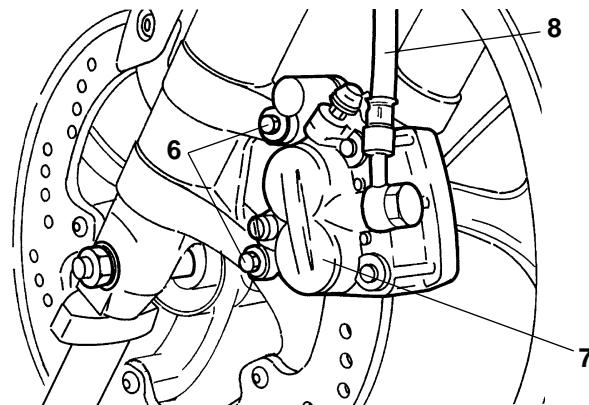

7

Remove the front brake control (9), brake fluid reservoir (10) and front brake caliper (7).

▲ WARNING

When refitting, make sure the brake fluid tube (8) is not pinched.

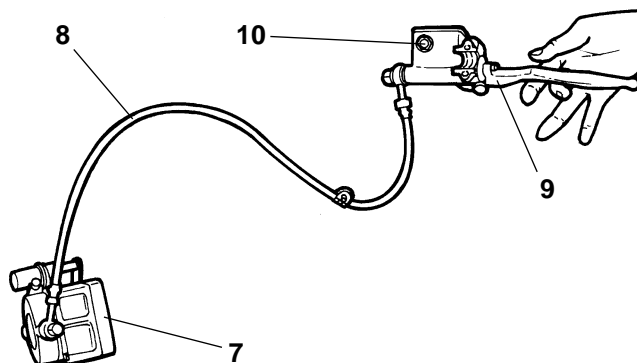

REMOVING THE RIGHT HANDLEBAR

Read carefully (PRECAUTIONS AND GENERAL INFORMATION).

Position the motorcycle on the stand.

Loosen and remove the screw (1).

Remove the washer.

Withdraw the right handlebar (2) with all its controls.

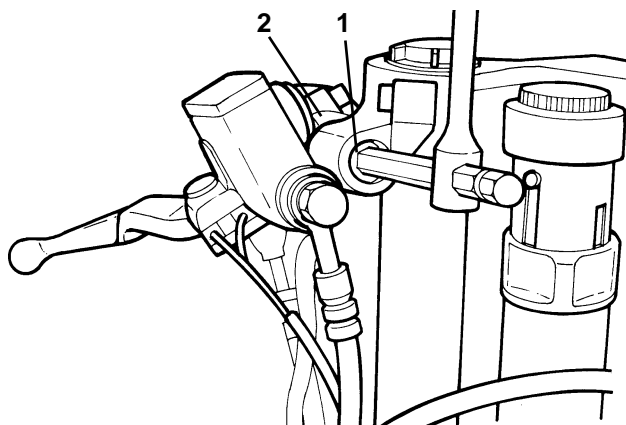

NOTE If necessary, remove the front brake control (REMOVING THE FRONT BRAKE CONTROL), the electrical controls (REMOVING THE RIGHT HANDLEBAR ELECTRICAL CONTROLS) and the throttle control (REMOVING THE THROTTLE CONTROL).

REMOVING THE LEFT HANDLEBAR

Read carefully (PRECAUTIONS AND GENERAL INFORMATION).

Position the motorcycle on the stand.

Loosen and remove the screw (3).

Remove the washer.

Withdraw the left handlebar (4) with all its controls.

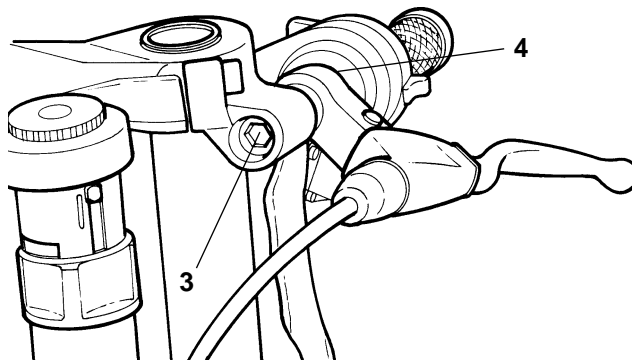

NOTE If necessary, remove the handgrip (REMOVING THE LEFT HANDLEBAR HANDGRIP), the electrical controls (REMOVING THE LEFT HANDLEBAR ELECTRICAL CONTROLS) and the clutch control (REMOVING THE CLUTCH CONTROL).

REMOVING THE IGNITION SWITCH/ STEERING LOCK

Read carefully (PRECAUTIONS AND GENERAL INFORMATION).

Position the motorcycle on the stand.

Switch the ignition key to the "⊗" position.

Remove the right and left handlebars (REMOVING THE RIGHT HANDLEBAR, REMOVING THE LEFT HANDLEBAR).

Free the fork top plate, following the instructions in the chapter ADJUSTING THE PLAY OF THE BEARINGS.

Free the wiring from the clamps.

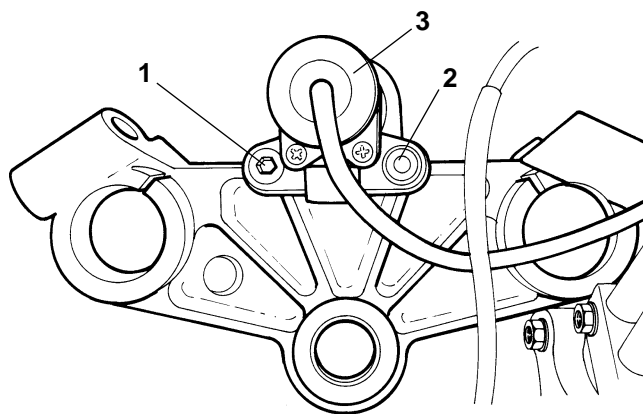

NOTE Prepare the same number of new clamps for refitting.

Disconnect the ignition switch/steering lock electrical connector.

▲ WARNING

When refitting, make sure the connector is plugged in properly.

Unscrew and remove the screw (1).

Use a chisel to cut into the head of the special screw (2) and turn it until it loosens.

Unscrew and remove the screw (2) with your fingers.

NOTE When refitting, use a new screw of the same type; tighten it up until the head shears off.

Remove the ignition switch/steering lock (3), withdrawing it from underneath.

7

REMOVING THE REAR VIEW MIRRORS

Position the motorcycle on the stand.

Slacken and remove the nut (4) and take off the washer (5), spring (6) and ball fitting (7).

▲ WARNING

Handle plastic and painted parts carefully, without scraping or damaging them.

Remove the rear view mirror (8).

Take off the cap (9), if it has come out of its housing.

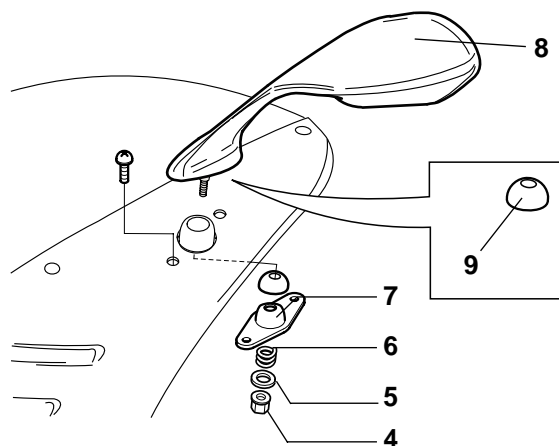

NOTE Repeat the same steps to remove the other rear view mirror.

NOTE After refitting, set the rear view mirrors correctly and tighten up the nuts to make sure they are securely fixed.

REMOVING THE WINDSHIELD

Position the motorcycle on the stand.
Using a screwdriver (1), remove the 7 studs (2) that secure the windshield (3) to the front mounting (4).
Remove the windshield (3).

NOTE Proceed carefully, without damaging the plastic parts.

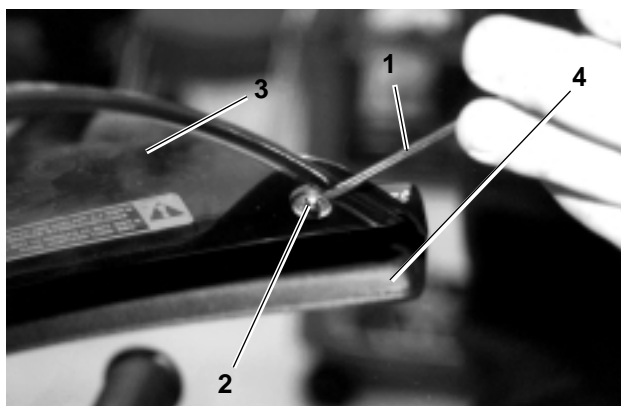

REMOVING THE FRONT FAIRING

Position the motorcycle on the stand.
Switch the ignition key to the "⊗" position.
Remove the rear view mirrors (REMOVING THE REAR VIEW MIRRORS).
Loosen and remove the 3 external screws (5) from the right of the front fairing (6).

Torque setting for screws (5):
5 Nm (0.5 kgm) [3.7 Ft-lb].

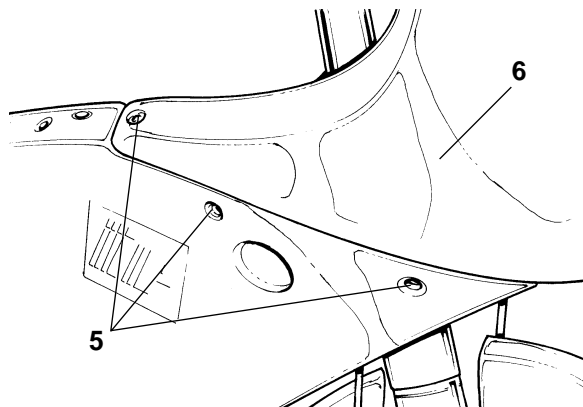

Loosen and remove the internal screw (7).

Torque setting for screw (7):
1 Nm (0.1 kgm) [0.7 Ft-lb].

NOTE The dashboard closing cowl has to be removed in order to remove the left side of the front fairing (REMOVING THE FILLER CAP).

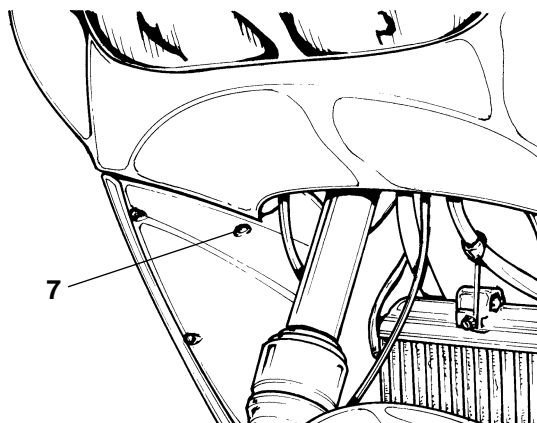

Move the front fairing (8) slightly forward.
Disconnect the headlight electrical connector (9).

NOTE When refitting, make sure the connector (9) is plugged in properly.
Handle plastic and painted parts carefully, to avoid scraping or damaging them.

Remove the headlight (REMOVING THE HEADLIGHT).

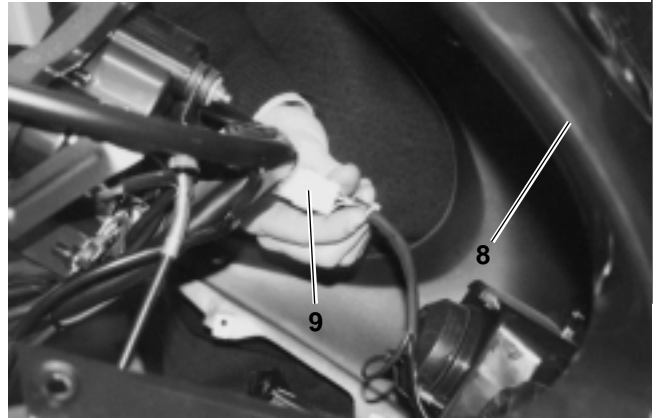

REMOVING THE HEADLIGHT

Read carefully (PRECAUTIONS AND GENERAL INFORMATION).

Position the motorcycle on the stand.
Switch the ignition key to the "⊗" position.
Remove the front fairing (REMOVING THE FRONT FAIRING).
Loosen and remove the screws (1).
Remove the headlight (2).

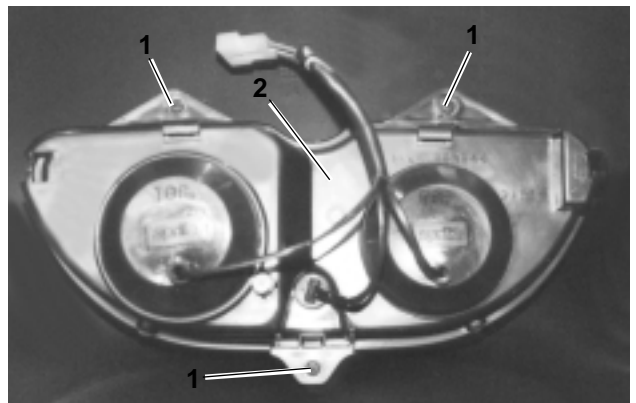

NOTE Handle plastic and painted parts carefully, without scraping or damaging them.
When refitting, make sure the headlight connector (9) is plugged in properly.

7

REMOVING THE DASHBOARD

Read carefully (PRECAUTIONS AND GENERAL INFORMATION).

Remove the front fairing (REMOVING THE FRONT FAIRING).
Loosen the ring nuts (3) on the odometer cable (4) and tachometer cable (5).
Withdraw the 2 cables.
Disconnect the dashboard (6) electrical connections.

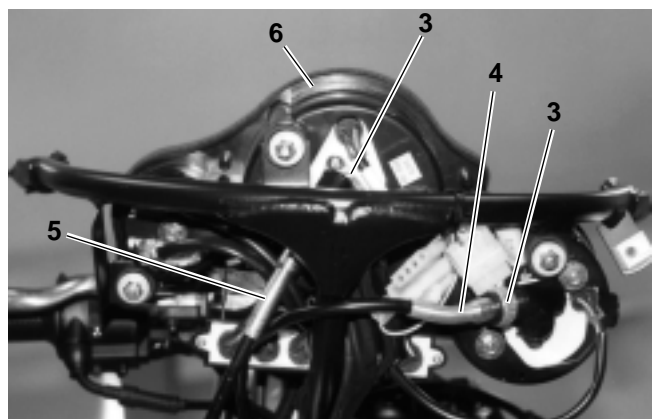

NOTE Make sure the electrical connections are correct when refitting.

Loosen and remove the 3 self-locking nuts (7) and washers.

Torque wrench setting for nut (7):
10 Nm (1 kgm) [7.4 Ft-lb].

Remove the dashboard (6).

NOTE Replace the rubber pads, if damaged.

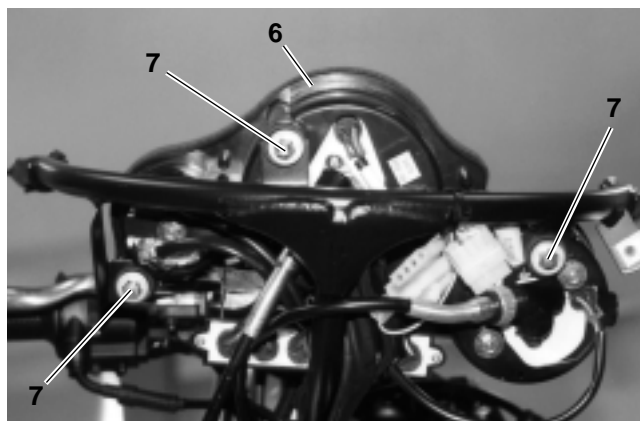

REMOVING THE INSTRUMENT PANEL FRAME

Read carefully (PRECAUTIONS AND GENERAL INFORMATION).

Position the motorcycle on the stand.

Switch the ignition key to the "⊗" position.

Remove the front fairing (REMOVING THE FRONT FAIRING).

Remove the dashboard (REMOVING THE DASHBOARD).

Free the instrument panel frame (1) from the wiring (2) by cutting the clamps (3).

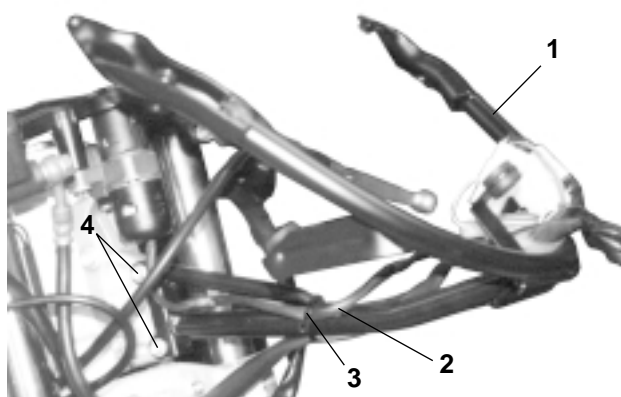

▲ CAUTION

When refitting, replace the clamps (3) with new ones.

Loosen and remove the 2 screws (4), taking off the corresponding self-locking flanged nuts from the other side.

Torque setting for screws (4):
15 Nm (1.5 kgm) [11.1 Ft-lb].

REMOVING THE FRONT MUDGUARD

Read carefully (PRECAUTIONS AND GENERAL INFORMATION).

Position the motorcycle on the stand.

Loosen and remove the 4 screws (1).

Torque setting for screws (1):

7 Nm (0.7 kgm) [5.2 Ft-lb].

Remove the self-locking nuts (2).

Loosen and remove the 2 screws (3) (right and left).

Torque setting for screws (3):

5 Nm (0.5 kgm) [3.7 Ft-lb].

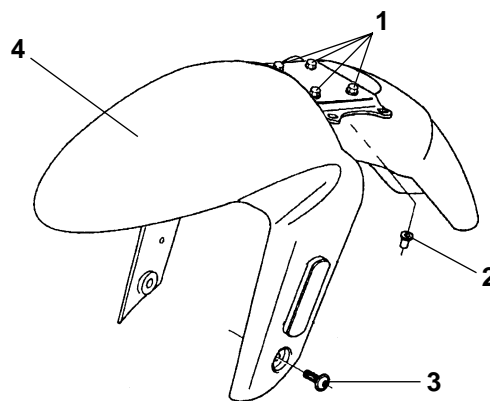

▲ WARNING

Handle plastic and painted parts carefully, without scraping or damaging them.

Withdraw the front mudguard (4) by grasping it from the front.

REMOVING THE FRONT DIRECTION INDICATORS

Read carefully (PRECAUTIONS AND GENERAL INFORMATION).

Position the motorcycle on the stand.

Switch the ignition key to the "⊗" position.

Remove the side fairings (REMOVING THE SIDE FAIRINGS).

Loosen and remove the screw (5) (right and left).

Take the corresponding nuts off from behind.

Remove the direction indicator (6).

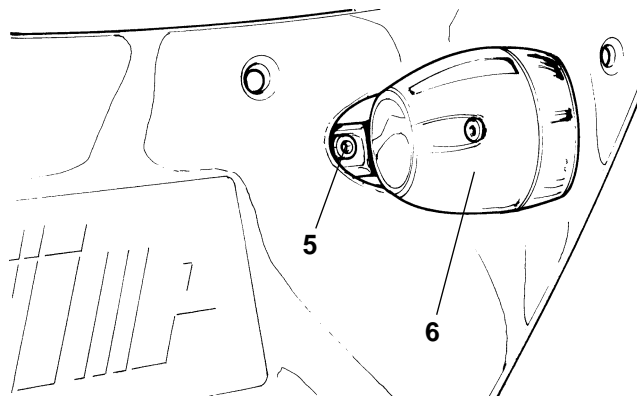

7

▲ WARNING

When removing the direction indicator (6), bring the electric wire and its connector out through the slot in the fairing.

REMOVING THE LOWER FAIRING

Read carefully (PRECAUTIONS AND GENERAL INFORMATION).

▲ WARNING

Handle plastic and painted parts carefully, without scraping or damaging them.

Position the motorcycle on the rear stand OPT.

▲ WARNING

Wait until the engine and exhaust muffler have cooled down completely.

Loosen and remove the 7 screws (1).

Torque setting for screws (1):
3 Nm (0.3 kgm) [2.2 Ft-lb].

Remove the internal fairings (2).

▲ WARNING

Repeat the procedure to remove the other fairing.

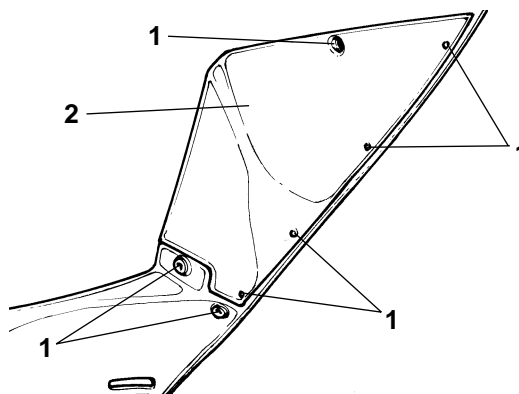

Loosen and remove the 8 screws (3).

Torque setting for screws (3):
3 Nm (0.3 kgm) [2.2 Ft-lb].

Remove the saddle cowl (4).

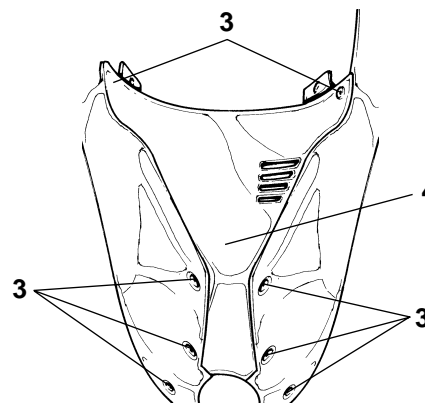

Loosen and remove the 3 screws (5).

Torque setting for screws (5):
3 Nm (0.3 kgm) [2.2 Ft-lb].

Lower the side stand.

Remove the left fairing panel extension (6).

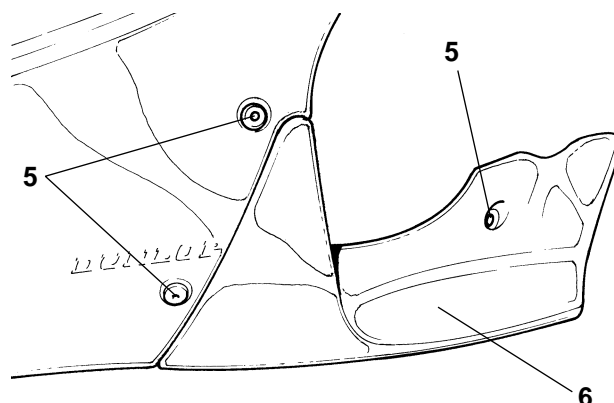

REMOVING THE REAR FAIRING

Read carefully (PRECAUTIONS AND GENERAL INFORMATION).

⚠ WARNING

Wait until the engine and exhaust muffler cool down completely.

Remove the rider saddle (REMOVING THE RIDER SADDLE).

Loosen and remove the nut (1) that attaches the passenger saddle to the rear fairing.

Torque setting for nut (1):
2 Nm (0.2 kgm) [1.5 Ft-lb].

Loosen and remove the pillion seat strap nut (2).

Torque setting for nut (2):
5 Nm (0.5 kgm) [3.7 Ft-lb].

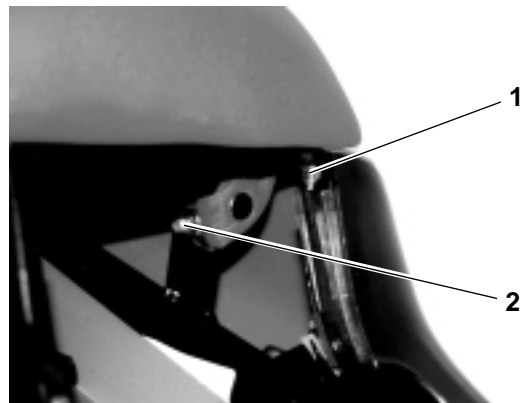

Loosen and remove the two screws (3).

Torque setting for screws (3):
3 Nm (0.3 kgm) [2.2 Ft-lb].

NOTE Repeat the operation for nuts (1) and (2) and screws (3) on the right-hand side of the motorcycle.



Loosen and remove the 4 screws (4) that attach the passenger saddle to the rear fairing.

Torque setting for screws (4):
3 Nm (0.3 kgm) [2.2 Ft-lb].

Remove the rear fairing (5).

NOTE If necessary, remove the passenger saddle (REMOVING THE PASSENGER SADDLE).

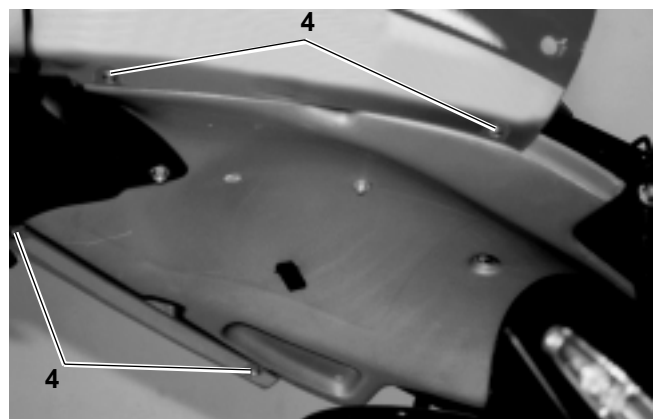

REMOVING THE REAR LIGHT

Read carefully (PRECAUTIONS AND GENERAL INFORMATION).

Switch the ignition key to the "⊗" position.

Carry out the procedure for changing the rear light bulb (CHANGING THE REAR LIGHT BULB).

Withdraw and slightly loosen the reflector (1).
Disconnect the bulb electrical connection (2).
Remove the reflector (1).
Loosen and remove the 2 retainer screws (3).

Torque setting for screws (3):
2 Nm (0.2 kgm) [1.5 Ft-lb].

Remove the taillight support (4).

NOTE When reassembling, tighten the two screws (3) carefully and moderately, to avoid damaging the taillight support (4).

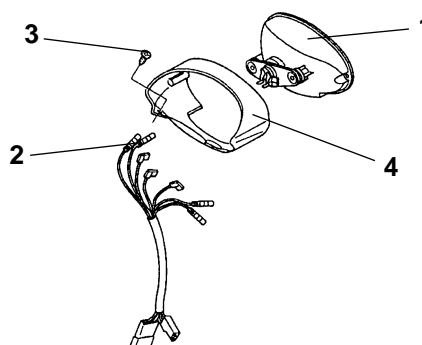

REMOVING THE LICENSE PLATE HOLDER

Read carefully (PRECAUTIONS AND GENERAL INFORMATION).

Switch the ignition key to the "⊗" position.

Remove the rear fairing (REMOVING THE REAR FAIRING).

Remove the taillight (REMOVING THE REAR LIGHT).

Remove the rear direction indicators (REMOVING THE REAR DIRECTION INDICATORS).

Loosen and remove the 3 screws (5).
Remove the three self-locking nuts (6).
Remove the license plate holder (7) from the pillar lower closing cowl (8).

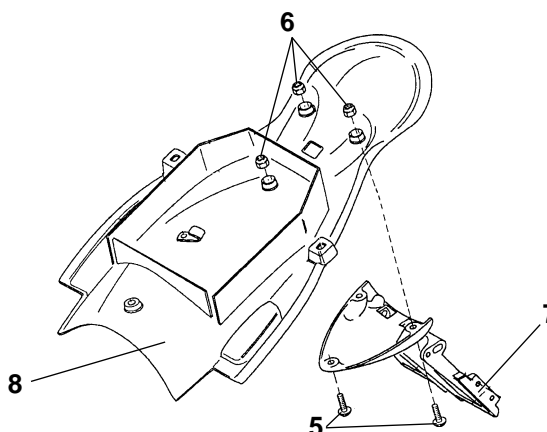

REMOVING THE PILLAR COVER

Read carefully (PRECAUTIONS AND GENERAL INFORMATION).

Remove the rider saddle (REMOVING THE RIDER SADDLE).

Raise up the tank (RAISING THE FUEL TANK).

Loosen and remove the 4 screws (1).

▲ WARNING

Handle plastic and painted parts carefully, without scraping or damaging them.

Remove the pillar cover (2).

Proceed in the same way for the right-hand pillar cover.

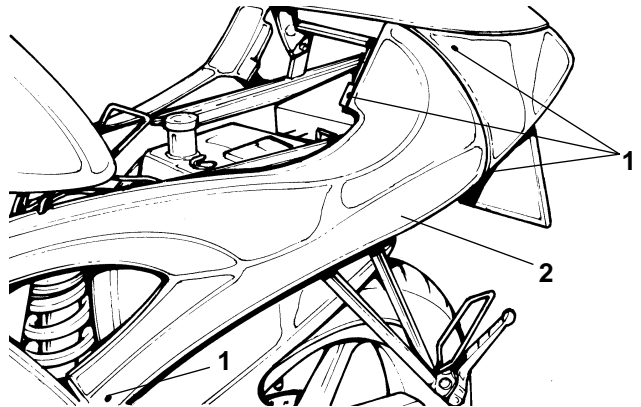

REMOVING THE REAR TURN SIGNALS

Read carefully (PRECAUTIONS AND GENERAL INFORMATION).

Remove the rear fairing (REMOVING THE REAR FAIRING).

Disconnect the electrical connections (3).

▲ WARNING

When refitting, make sure the electrical connector (3) is plugged in properly.

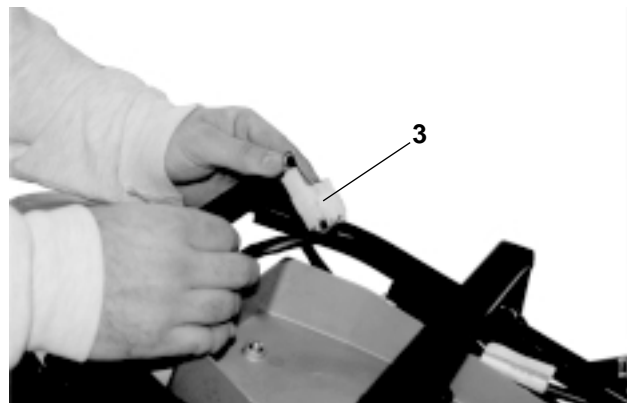

Loosen and remove the screws (4).

Take off the nuts (5).

Remove the turn signals (6).

NOTE When removing the turn signal (6), bring the electric wire and its connector out through the slot in the pillar lower closing cowl and license plate holder.

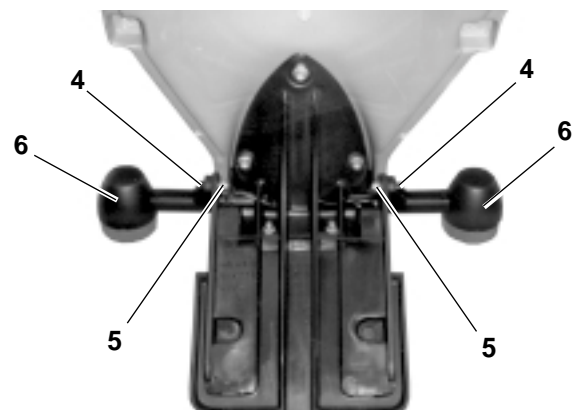

REMOVING THE REAR MUDGUARD

Read carefully (PRECAUTIONS AND GENERAL INFORMATION).

Position the motorcycle on the stand.

▲ WARNING

Wait until the engine and exhaust muffler cool down completely.

Loosen and remove the 2 screws (1).

**Torque setting for screws (1):
5 Nm (0.5 kgm) [3.7 Ft-lb].**

Remove the rear mudguard (2).

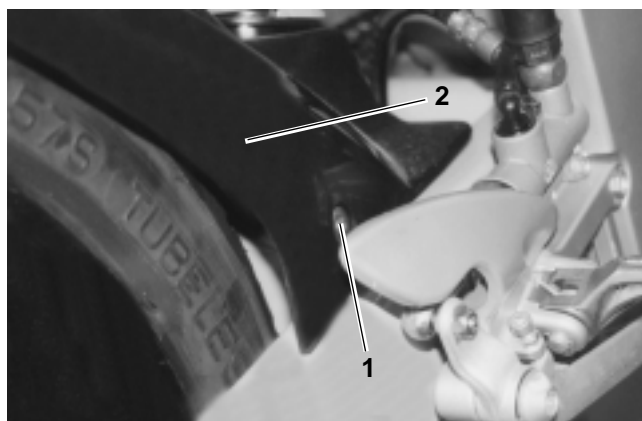
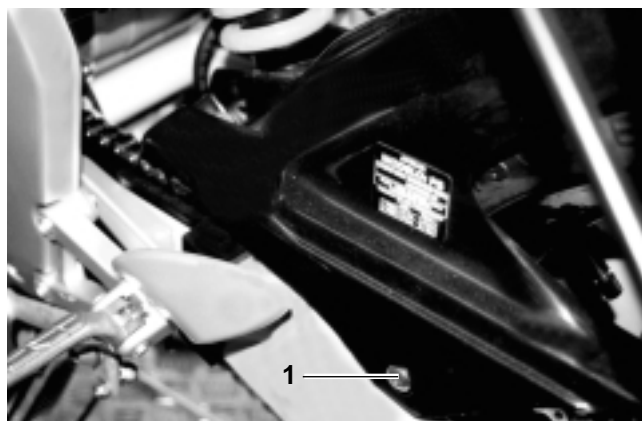

REMOVING THE REAR FOOTREST SUPPORTS

Read carefully (PRECAUTIONS AND GENERAL INFORMATION).

Position the motorcycle on the stand.

▲ CAUTION

Wait until the engine and exhaust muffler cool down completely.

Loosen and remove the screw (3) (r.h. side footrest only).

**Torque setting for screws (3):
12 Nm (1.2 kgm) [8.8 Ft-lb].**



Loosen and remove the screws (4) under the pillar cover.

Torque setting for screws (4):
24 Nm (2.4 kgm) [17.7 Ft-lb].

Remove the footrest support (5) complete with footrest.

If necessary, remove the footrest (5) (REMOVING THE REAR FOOTRESTS).

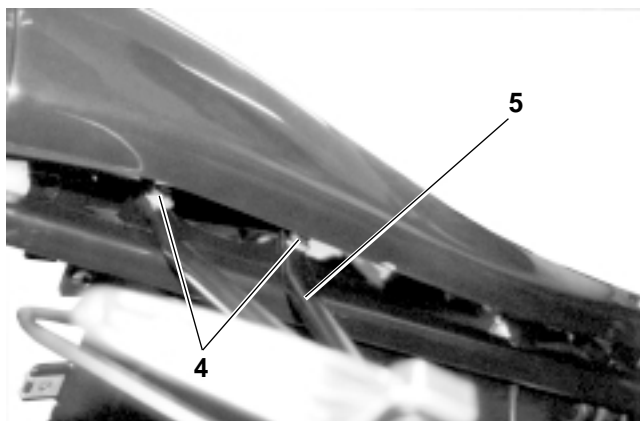

REMOVING THE REAR FOOTRESTS

Read carefully (PRECAUTIONS AND GENERAL INFORMATION).

Position the motorcycle on the stand.

⚠ CAUTION

Wait until the engine and exhaust muffler cool down completely.

Remove the retainer ring (1).
 Withdraw the pin (2).

⚠ WARNING

Be careful not to lose the ball (3) pushed out by the spring (4).

Remove the footrest (5) and take off the shim (6), ball (3) and spring (4).

NOTE If necessary, repeat the procedure for the removal of the other footrest.

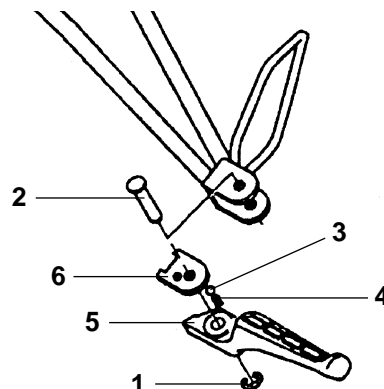

7

REMOVING THE FRONT FOOTREST SUPPORT (LEFT SIDE)

Read carefully (PRECAUTIONS AND GENERAL INFORMATION).

Position the motorcycle on the stand.

⚠ CAUTION

Wait until the engine and exhaust muffler cool down completely.

Remove the shift lever (1) (REMOVING THE SHIFT LEVER).

Loosen and remove the screws (2).

**Torque setting for screws (2):
25 Nm (2.5 kgm) [18.4 Ft-lb].**

Remove the front footrest support (3) complete with footrest (4).

If necessary, remove the front footrest (4) (REMOVING THE FRONT FOOTREST).

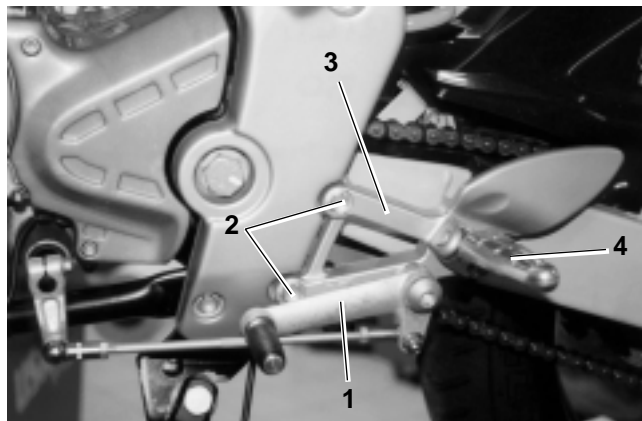

REMOVING THE FRONT FOOTREST SUPPORT (RIGHT SIDE)

Read carefully (PRECAUTIONS AND GENERAL INFORMATION).

Position the motorcycle on the stand.

▲ CAUTION

Wait until the engine and exhaust muffler cool down completely.

Remove the brake pedal (5) (REMOVE THE BRAKE PEDAL).

Loosen and remove the screws (6).

**Torque setting for screw (6):
10 Nm (1.0 kgm) [7.4 Ft-lb].**

Temporarily attach the rear brake master cylinder (7) to the frame in a vertical position, using adhesive tape.

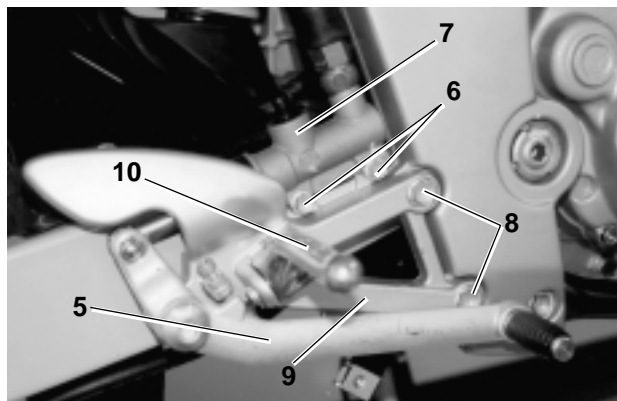

Loosen and remove the screws (8).

**Torque setting for screws (8):
25 Nm (2.5 kgm) [18.4 Ft-lb].**

Remove the front footrest support (9), complete with footrest.

If necessary, remove the front footrest (10) (REMOVING THE FRONT FOOTREST).

REMOVING THE FRONT FOOTREST

Read carefully (PRECAUTIONS AND GENERAL INFORMATION).

Position the motorcycle on the stand.

▲ CAUTION

Wait until the engine and exhaust muffler cool down completely.

Remove the retainer ring (1).
Withdraw the pin (2).
Take off the footrest (3) and the spring (4).

NOTE If necessary, repeat the procedure to remove the other front footrest.

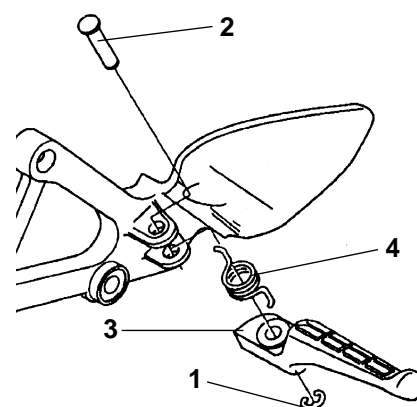

REMOVING THE SHIFT LEVER

Read carefully (PRECAUTIONS AND GENERAL INFORMATION).

Position the motorcycle on the stand.

Loosen and remove the nut (5).

Torque setting for nut (5):
5 Nm (0.5 kgm) [3.7 Ft-lb].



7

Loosen and remove the gear shift lever (6).

Torque setting for shift lever pin (6):
12 Nm (1.2 kgm) [8.8 Ft-lb].

Remove the 2 Belleville washers (7), the washer (8) and the nut (9).

Remove the shift lever (10).

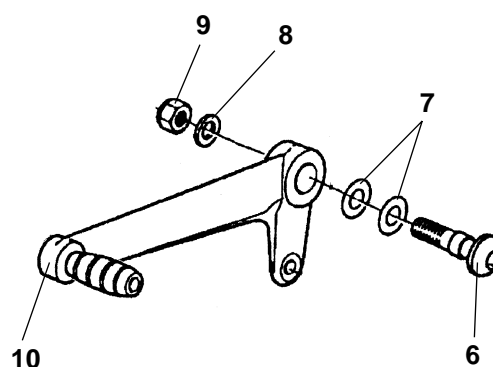

REMOVING THE BRAKE PEDAL

Read carefully (PRECAUTIONS AND GENERAL INFORMATION).

Position the motorcycle on the stand.

Loosen and remove the nut (1).

Torque setting for nut (1):
5 Nm (0.5 kgm) [3.7 Ft-lb].



Release the spring (2).

Loosen and remove the brake lever pin (3).

Torque setting for brake lever pin (3):
12 Nm (1.2 kgm) [8.8 Ft-lb].

Remove the 2 Belleville washers (4), the washer (5) and the nut (6).

Remove the brake pedal (7).

To refit, go through the removal procedure in reverse order, adjusting the rear brake if necessary (ADJUSTING THE REAR BRAKE).

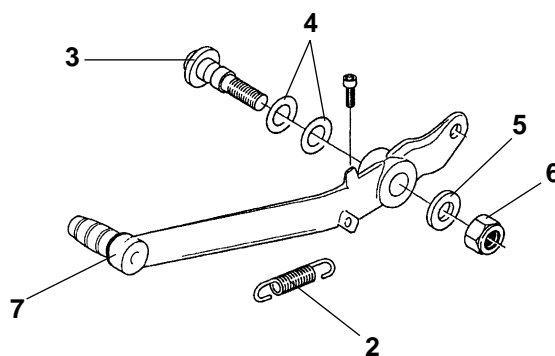

REMOVING THE EXHAUST PIPE

Read carefully (PRECAUTIONS AND GENERAL INFORMATION).

The exhaust pipe and muffler must be cleaned every 4,000 km (2,500 miles).

⚠ CAUTION

It is against the law to use the motorcycle without an exhaust pipe and/or muffler.

It is also against the law to replace these parts with non-approved spare parts.

NOTE Before proceeding, allow the engine and exhaust to cool down to ambient temperature, to avoid possible burns.

Remove the side fairings (REMOVING THE THE SIDE FAIRINGS).

Remove the saddle cowl (REMOVING THE LOWER FAIRING).

Unhook the 2 springs (8) that attach the exhaust pipe to the cylinder exhaust manifold.

⚠ CAUTION

Check the state of the 2 springs (8), replacing them if damaged.

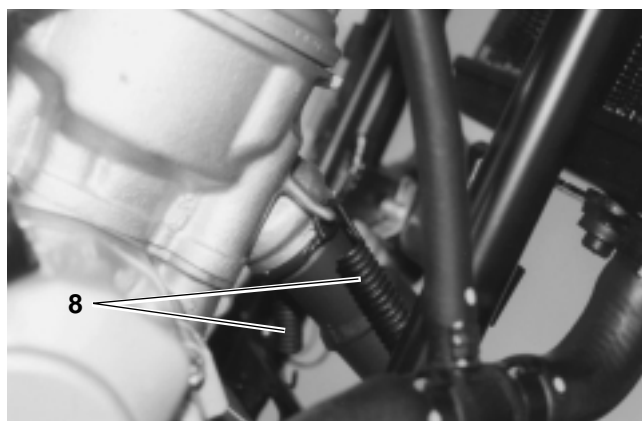

Loosen and remove the screw (9).

**Torque setting for screw (9):
12 Nm (1.2 kgm) [8.8 Ft-lb].**

Take off the washer (10).

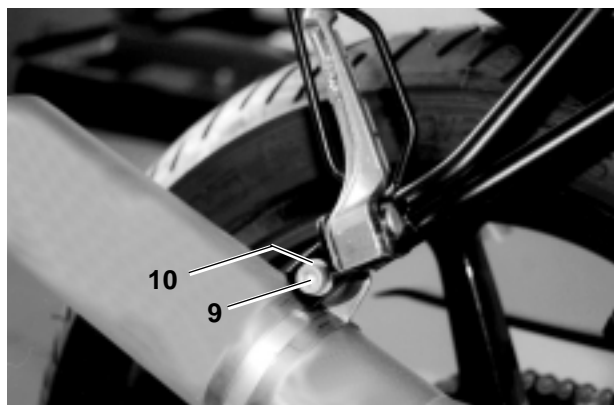

The exhaust pipe must be supported during this operation.

Loosen and remove the screw (11).

**Torque setting for screw (11):
12 Nm (1.2 kgm) [8.8 Ft-lb].**

Take off the washer (12).

▲ WARNING

Plug the exhaust pipe opening, to prevent foreign material from entering.

Withdraw the exhaust pipe (13) in a downward direction.

Clean if necessary (CLEANING THE EXHAUST PIPE AND MUFFLER).

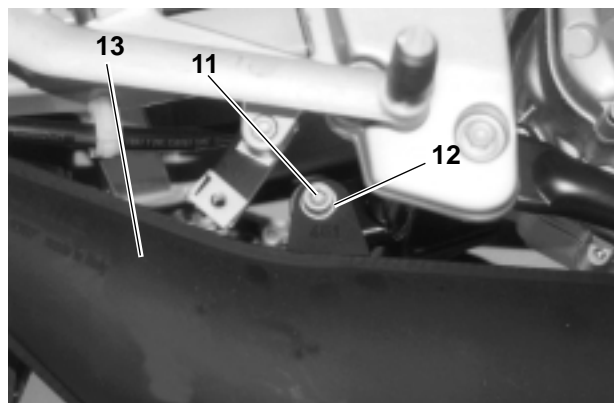

REMOVING THE MUFFLER

Read carefully (**PRECAUTIONS AND GENERAL INFORMATION**) and (**SERVICING SCHEDULE**).

The exhaust pipe and muffler must be cleaned every 4,000 km (2,500 miles).

▲ WARNING

It is against the law to use the motorcycle without an exhaust pipe and/or muffler.

It is also against the law to replace these parts with non-approved spare parts.

▲ CAUTION

Before proceeding, allow the engine and exhaust to cool down to ambient temperature, to avoid possible burns.

Unscrew and remove the screw (1) and take off the washer.

Take off the support (2).

▲ WARNING

Support the muffler (3) to stop it from falling accidentally.

Loosen and remove all three nuts (4); unscrew them and remove them.

NOTE When refitting, replace all three nuts (4), and snug them finger tight. Then, tighten to the specified torque.

Withdraw the muffler (3) from the flange (5).

NOTE When refitting, insert the exhaust muffler (3) into the flange (5), checking that the end of the pipe (6) is pointing down.

Remove the gasket (7).

NOTE When refitting, replace the gasket (7) with a new one.

Clean any deposits off the flange (5) and the gasket seat (8).

▲ WARNING

Plug the exhaust pipe space opening, to prevent foreign material from entering.

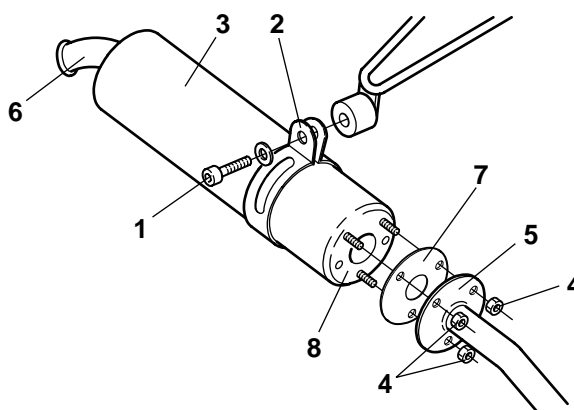

CLEANING THE EXHAUST PIPE AND MUFFLER

Read carefully (**PRECAUTIONS AND GENERAL INFORMATION**) and (**SERVICING SCHEDULE**).

Remove the exhaust muffler (**REMOVING THE MUFFLER**).

NOTE Get a flexible tube brush (1) of suitable diameter.

CAUTION

Do not use any other tool except the tube brush. Do not insert any objects, especially small objects, into the exhaust pipe or muffler. They will stay inside, you won't be able to get them out. Be careful not to push the brush too far into the muffler.

Observe the distances that the brush may be inserted into the muffler safely, given below.

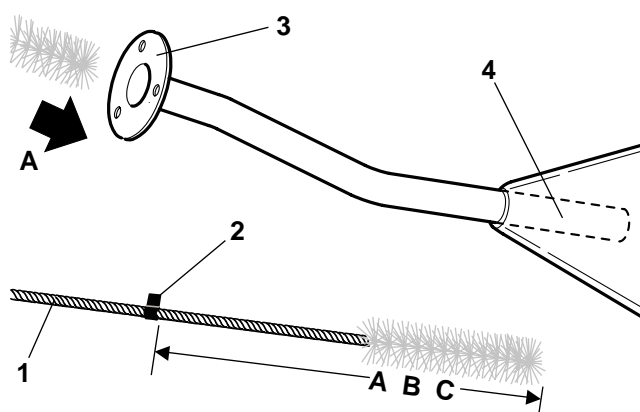

Apply a reference mark (2) to the tube brush (such as colored sticky tape) to mark the maximum cleaning depth.

Depth to be marked on tube brush:

A = 320 mm (12.6 in); **B** = 125 mm (4.9 in); **C** = 250 mm (9.8 in)

NOTE When you have finished cleaning, remove your tape, and thoroughly clean the brush.

Observing cleaning depth (**A**), insert the brush and work it vigorously into the flange hole (3).

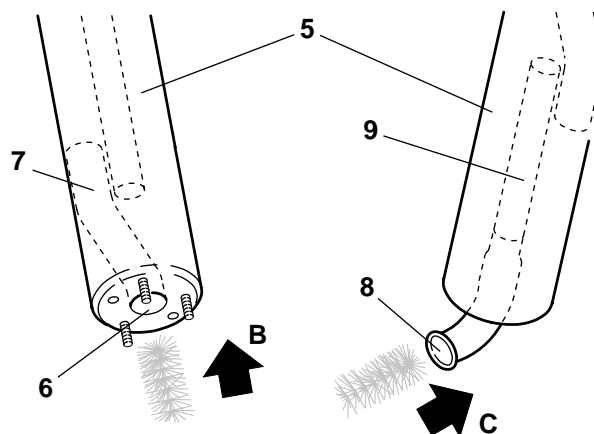

NOTE Work the tube brush in and out in a straight line. Clean the end of the exhaust pipe (4) with the tube brush.

NOTE For the next cleaning operations, position the muffler (5) vertically and insert the tube brush from underneath.

Observing the cleaning depth (**B**): insert the tube brush in the entry hole (6).

Clean the entry pipe (7) with the tube brush.

Rotate the muffler 180°.

Observing the cleaning depth (**C**): insert the tube brush into the outlet hole (8).

Clean the outlet pipe (9) with the tube brush.

REMOVING THE SIDE STAND

Read carefully (PRECAUTIONS AND GENERAL INFORMATION).

Position the motorcycle on the rear stand OPT.

Rear stand: 8705021.

▲ WARNING

The sidestand is equipped with a very powerful spring. If you should get a finger wedged between the spring and the stand, or between the spring and the frame, you will be seriously injured. Take great care when performing this task. Wear heavy work gloves.

Unhook the two springs (1) with a spring removal tool, as shown.

▲ WARNING

When refitting, make sure the 2 springs (1) are positioned correctly.

Remove the stand return plate (2).

Work with the stand in the rest position.

Loosen and remove the screw (3).

Torque setting for screws (3):
25 Nm (2.5 kgm) [18.4 Ft-lb].

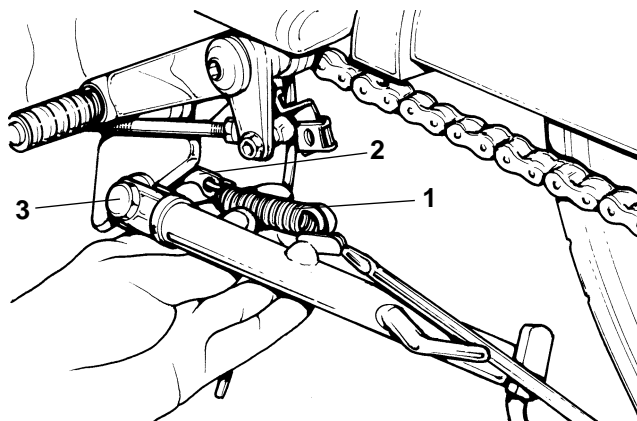

Remove the retainer nut (4) from the other end of the screw (3).

Remove the stand (5).

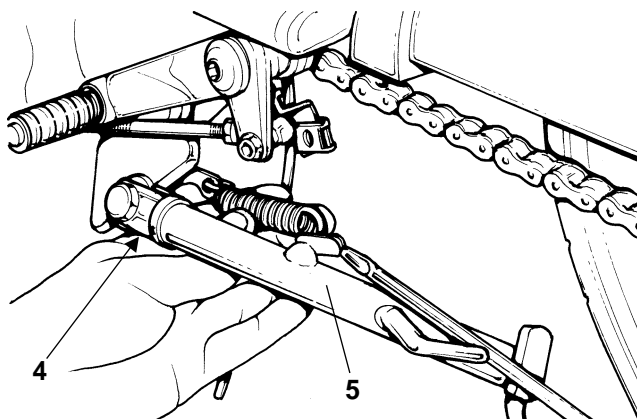

REMOVING THE CHAIN GUIDE

Read carefully (PRECAUTIONS AND GENERAL INFORMATION).

Remove the swing arm (REMOVING THE SWING ARM).

Loosen and remove the screw (1).

Torque setting for screw (1):
3 Nm (0.3 kgm) [2.2 Ft-lb].

Remove the cap (2).

Remove the chain guide (3).

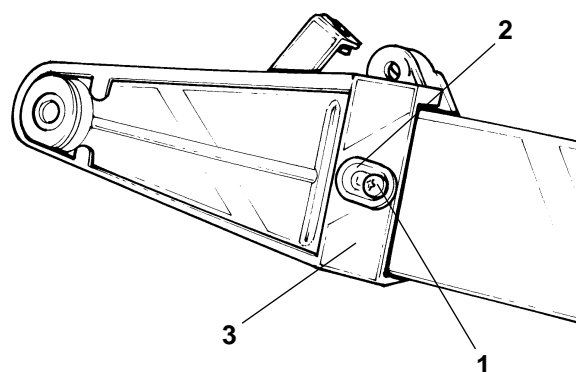

REMOVING THE PILLAR

Read carefully (PRECAUTIONS AND GENERAL INFORMATION).

Remove the fairings (REMOVING THE SIDE FAIRINGS).

Position the motorcycle on the stand.

Remove the rider saddle (REMOVING THE RIDER SADDLE).

Remove the fuel tank (REMOVING THE FUEL TANK).

Remove the battery (REMOVING THE BATTERY).

Remove the rear fairing with the passenger saddle (REMOVING THE REAR FAIRING).

Remove the pillar cover (REMOVING THE PILLAR COVER).

Remove the rear footrest supports (REMOVING THE REAR FOOTREST SUPPORTS).

Remove the pillar support lower closing cowl with the license plate holder and taillight (REMOVING THE PILLAR SUPPORT LOWER CLOSING COWL).

Remove the two stroke oil tank (REMOVING THE 2 STROKE OIL TANK).

Cut off and discard the clamps (4) that secure the wiring to the pillar.

NOTE Get new clamps (4) for refitting.

Disconnect the fuse electrical connections (5).

When refitting, make sure the electrical connection is properly connected.

Remove the rubber fuse holder (6) with its fuses (7).

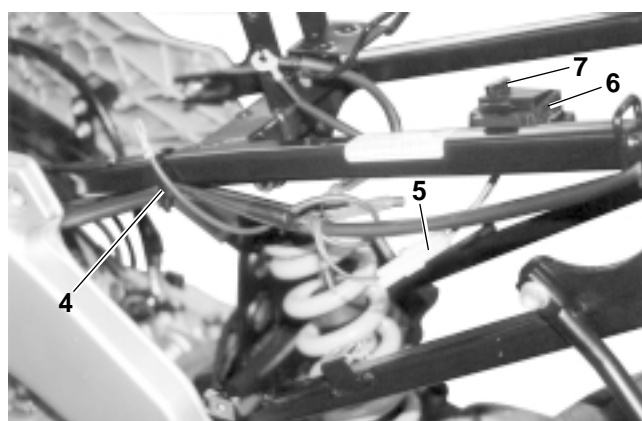

Loosen and remove the screw (8).

Torque setting for screw (8):
3 Nm (0.3 kgm) [2.2 Ft-lb].

Tape or wire the brake fluid reservoir (9) in a vertical position on the frame to prevent the brake fluid from spilling out.

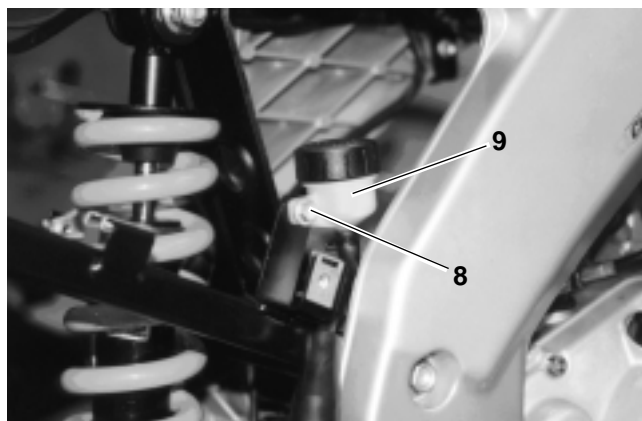

Loosen and remove the screw (10).

Torque setting for screw (10):
5 Nm (0.5 kgm) [3.7 Ft-lb].

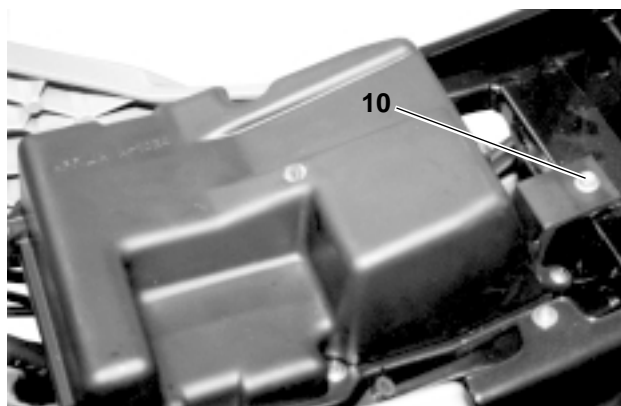

Loosen and remove the screw (11) and withdraw the rear shock absorber from its housing.

Torque setting for screw (11):
48 Nm (4.8 kgm) [35.4 Ft-lb].

Remove the washer (12) and nut.

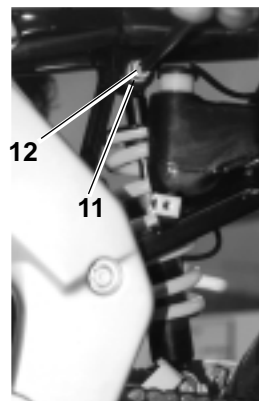

Loosen and remove the nut (13).

Torque setting for nut (13):
24 Nm (2.4 kgm) [17.7 Ft-lb].

Withdraw the mounting bolt that secures the engine to the frame.

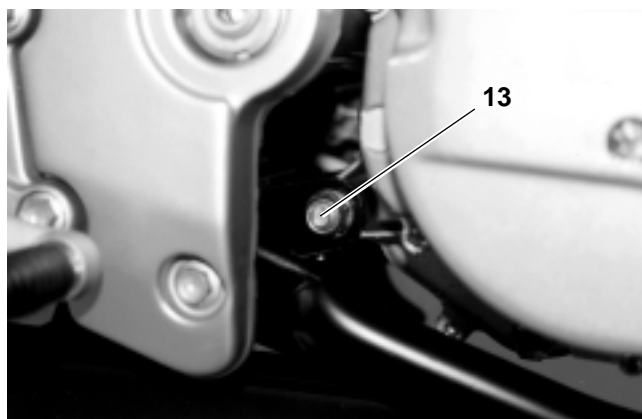

NOTE The following operation must be performed from the opposite side of the motorcycle.

Loosen and remove the 2 screws (14) and (15).

Torque setting for screw (14):
24 Nm (2.4 kgm) [17.7 Ft-lb].

Torque setting for screw (15):
47 Nm (4.7 kgm) [34.7 Ft-lb].

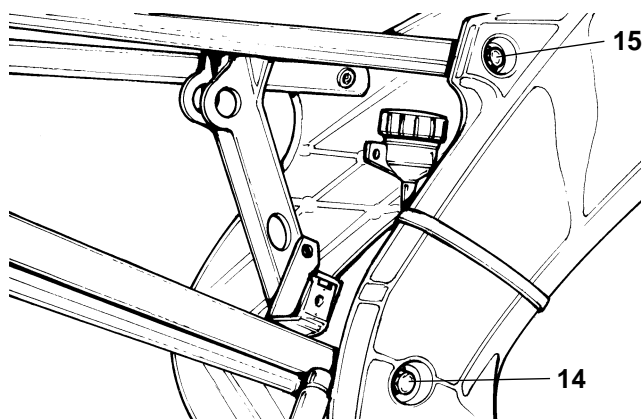

Withdraw the pillar (16) rearward.

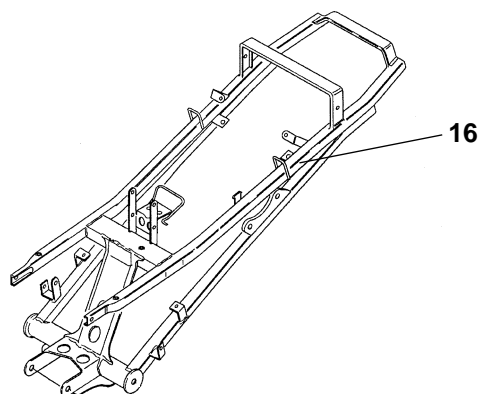

FRONT WHEEL

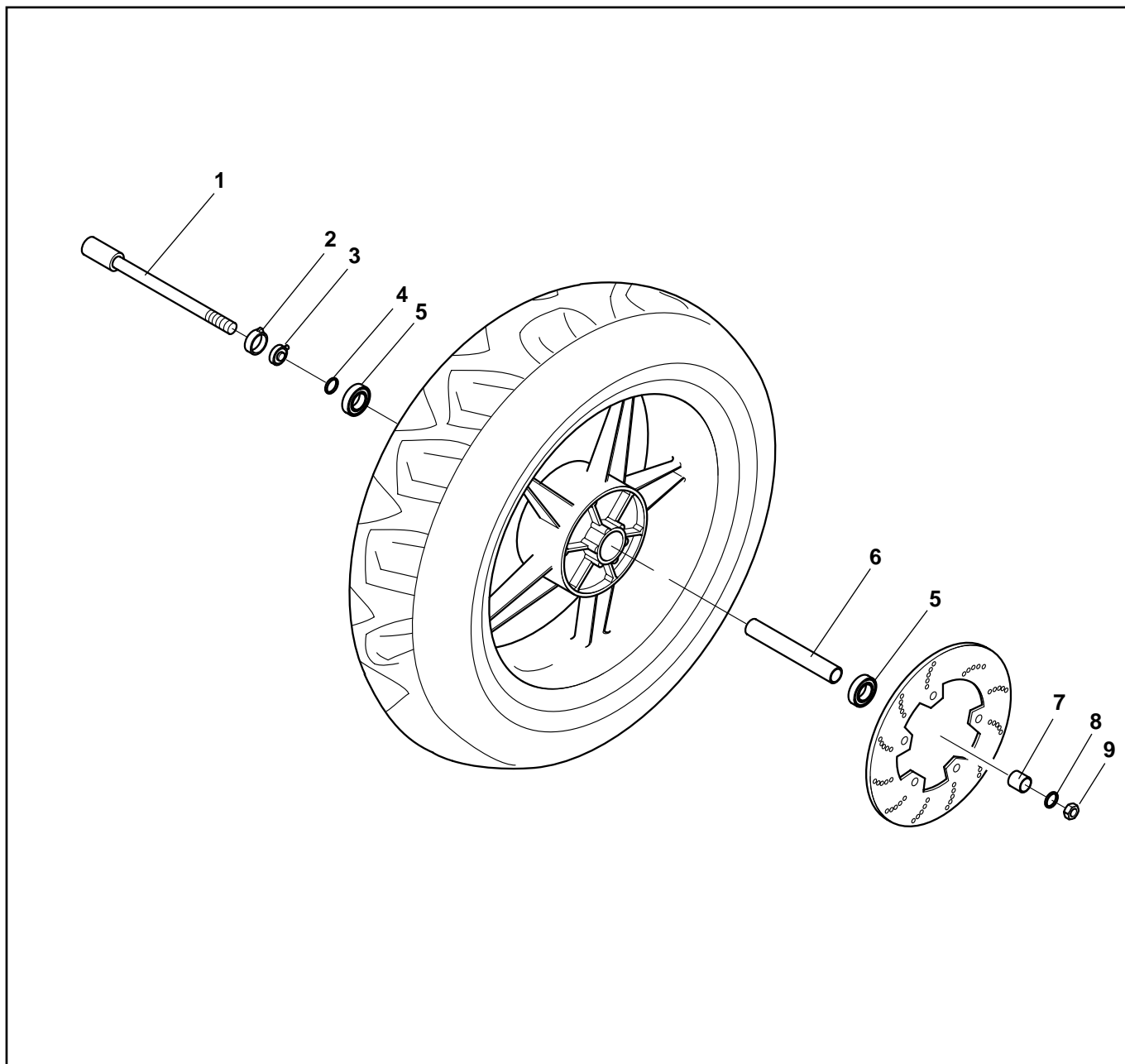

Key

- 1) Axle
- 2) Odometer drive cover
- 3) Odometer drive
- 4) Washer
- 5) Bearing
- 6) Internal spacer
- 7) External spacer
- 8) Washer
- 9) Nut

REMOVING THE COMPLETE FRONT WHEEL

Read carefully (SERVICING SCHEDULE).
While disassembling and reassembling the wheel,
pay extra care not to damage the brake lines,
discs or pads.

NOTE You must use the appropriate front and rear
support stands to remove the front wheel.

Rear stand: 8705021.

Position the motorcycle on the appropriate rear
support stand, (POSITIONING THE MOTORCYCLE
ON THE REAR SUPPORT STAND OPT).

▲ WARNING

Make sure that the motorcycle is stable.

**Brake caliper screw (1) tightening torque:
16.2 Ft-lb (2.2 kgm) [22 Nm].**

Remove the two screws (1) that fasten the front brake
caliper (2).

Remove the brake caliper (2) from the disc, leaving it
attached to its line (3).

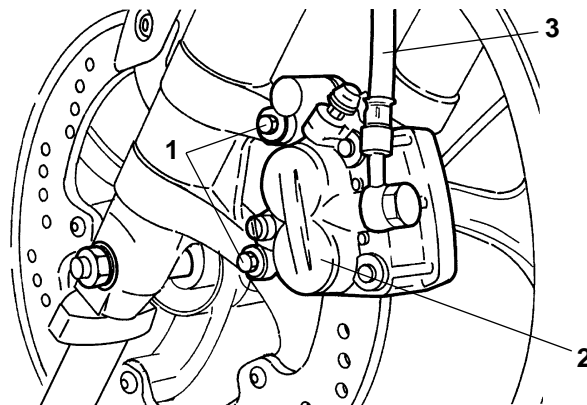

▲ CAUTION

Never touch the front brake lever after removing
the brake caliper from the disc. If you do, the
caliper pistons may be pushed out of their seats,
and brake fluid will be spilled.

Place a support (4) under the tire, in such a way as to
keep the wheel in its position after loosening it.

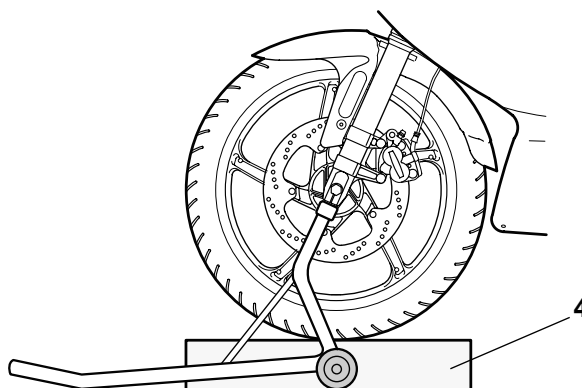

Prevent the axle (5) from rotating with an appropriate Allen wrench.

Remove the nut (6) and washer (7).

Wheel nut (6) tightening torque:
59 Ft-lb (8 kgm) [80 Nm].

Loosen the axle clamp screw (8), using the appropriate Allen wrench.

Push the axle (5) partly out of the front fork by tapping the threaded end with a rubber hammer or wooden drift.

NOTE Observe the arrangement of the speedometer drive (9) and of the spacer ring (10), in order to be able to reassemble them correctly.

Support the front wheel and remove the axle manually.

Remove the spacer ring (10).

Remove the wheel by pulling it forward.

Disconnect the speedometer drive (9).

Remove the washers (11).

Remove the speedometer drive cover (12).

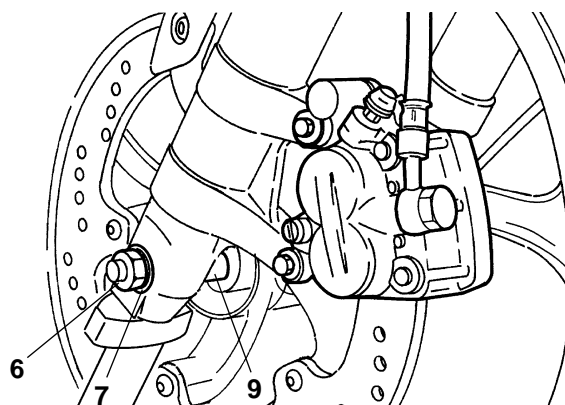
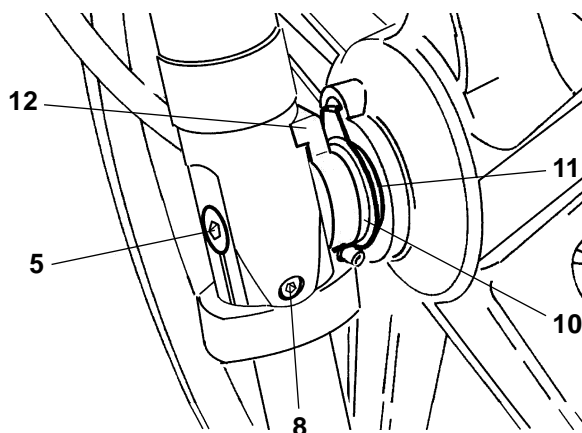

DISASSEMBLING THE FRONT WHEEL

Read carefully (PRECAUTIONS AND GENERAL INFORMATION).

Remove the wheel (REMOVING THE COMPLETE FRONT WHEEL).

Clean both sides of the hub with a clean cloth.

Using the correct drift, gently tap out the right bearing (1) and the left bearing (2).

NOTE Each time they are disassembled the bearings must be checked (CHECKING THE COMPONENTS) and replaced with new ones if necessary.

Remove the spacer (3).

Clean the inside of the hub thoroughly.

NOTE Wash all components with clean fire proof solvent.

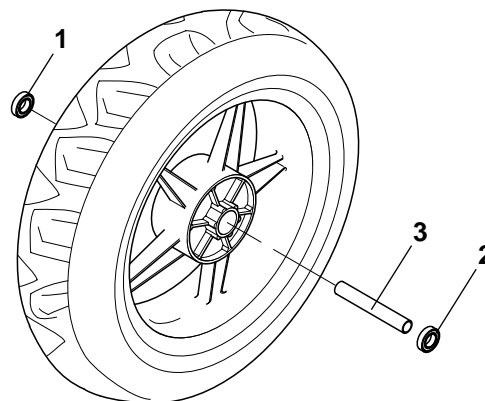

▲ WARNING

When refitting the bearings, use a drift with the same diameter as the outside race of the bearings. Do not drive on the balls and/or the inner ring.

Make sure the following parts are fitted together perfectly:

the right bearing (1) against the hub;
the spacer (3) against the right bearing (1);
the left bearing (2) against the spacer (3).

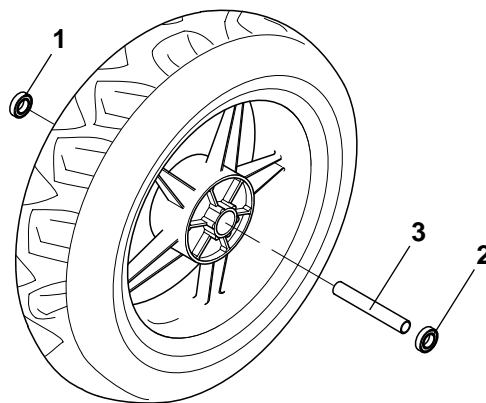
**▲ WARNING**

Check the condition of all the components, especially those listed below.

BEARINGS

Turn the internal race (1) manually; it must turn smoothly, without sticking and/or noise.

There must be no end play.

Any bearings not meeting these requirements must be renewed.

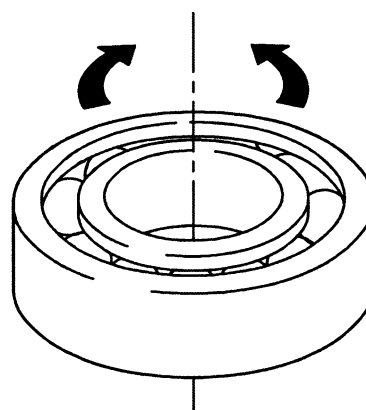

WASHERS

Check the condition of the washers, renewing them if damaged.

7

AXLE

Using a dial gauge, check the runout on the axle (4). If the runout exceeds the specified limit, renew it.

Maximum runout: 0.25 mm (0.01 in).

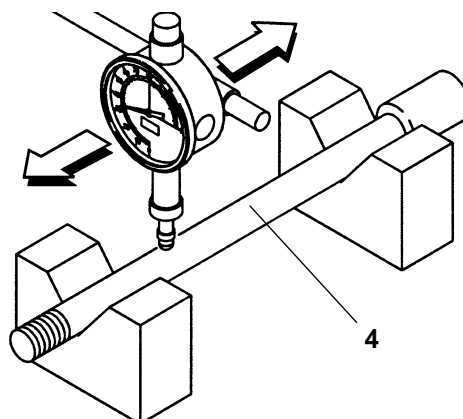

RIM

Using a dial gauge, check that the radial runout (A) and axial runout (B) on the rim (5) do not exceed the specified limits.

Excessive runout is usually caused by worn or damaged bearings.

If, after replacing the bearings, the runout is still not within the stated limit, replace the rim (5).

Maximum radial and axial runout: 2 mm (0.08 in).

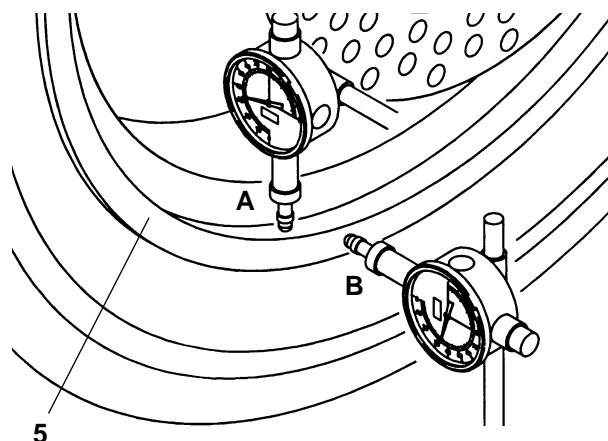

TIRE

Check the condition of the tire (TIRES).

REASSEMBLY FRONT WHEEL

Read carefully (SERVICING SCHEDULE).

Apply a thin film of lubricating grease to the front axle (1), (LUBRICANT CHART).

Install washer (2) on the speedometer drive (3) (boss side (4)).

Position the boss (4) of the speedometer drive (3) in the appropriate seat on the wheel hub.

Locate the cover (5) over the speedometer drive (3).

Position the spacer ring (6) in its seat on the wheel.

Position the wheel between the fork rods on the support (7).

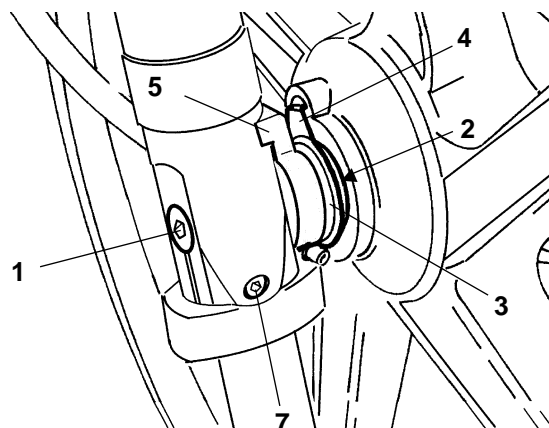

▲ WARNING

Danger of injury. Keep your fingers clear. Do not attempt to line up the wheel and the axle clamps with your fingers. Failure to observe this warning can lead to amputation of a finger or other serious injury.

Move the wheel around until the axle hole and the axle clamps are aligned.

Push in the axle (1) completely.

Install the washer (8) and nut (9). Tighten finger tight. Ensure that the cover (5) is correctly installed on the fork.

Prevent the axle (1) from rotating using the Allen wrench.

Tighten the nut (9) to its appropriate tightening torque.

Nut (9) tightening torque:
59 Ft-lb (8 kgm) [80 Nm].

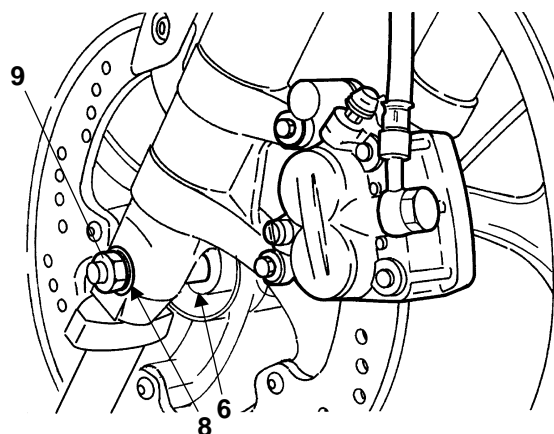

▲ CAUTION

While reassembling the wheel, be careful not to damage the brake line, the disc and the pads.

Install the brake caliper (10) over the disc and position it so that its fastening holes and the holes on the support are aligned.

NOTE When reassembling the brake caliper, replace the caliper screws (11) with two new screws of the same type.

Tighten the two screws (11) to the appropriate torque.

Brake caliper screw (11) tightening torque:
16.2 Ft-lb (2.2 kgm) [22 Nm].

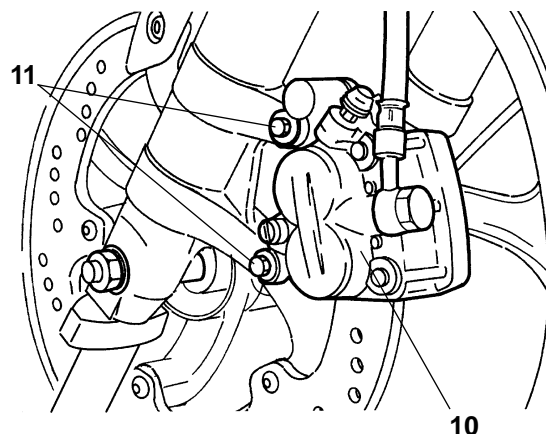

Remove the front support stand **OPT.**

Remove the rear support stand **OPT.**

Apply the front brake lever, and then push down on the handlebars, compressing the fork springs several times. This will align the fork tubes.

Tighten the axle clamp screw (12).

Screw (12) tightening torque:
5.9 Ft-lb (0.8 kgm) [8 Nm].

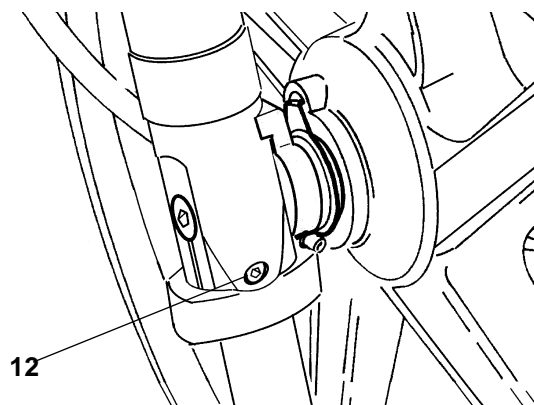
**▲ WARNING**

After servicing the brakes, always check them for function.

It may be necessary to have your dealer bleed the system, or there may be some other problem with the brake system.

Never ride your motorcycle in traffic immediately after servicing the brakes. Always apply the brake pedal or lever several times before riding your motorcycle.

Then, try your motorcycle in a parking lot or other safe area with little traffic to ensure that the brakes are working properly. Failure to observe this warning can lead to a serious accident with subsequent serious injury or death.

FRONT BRAKE

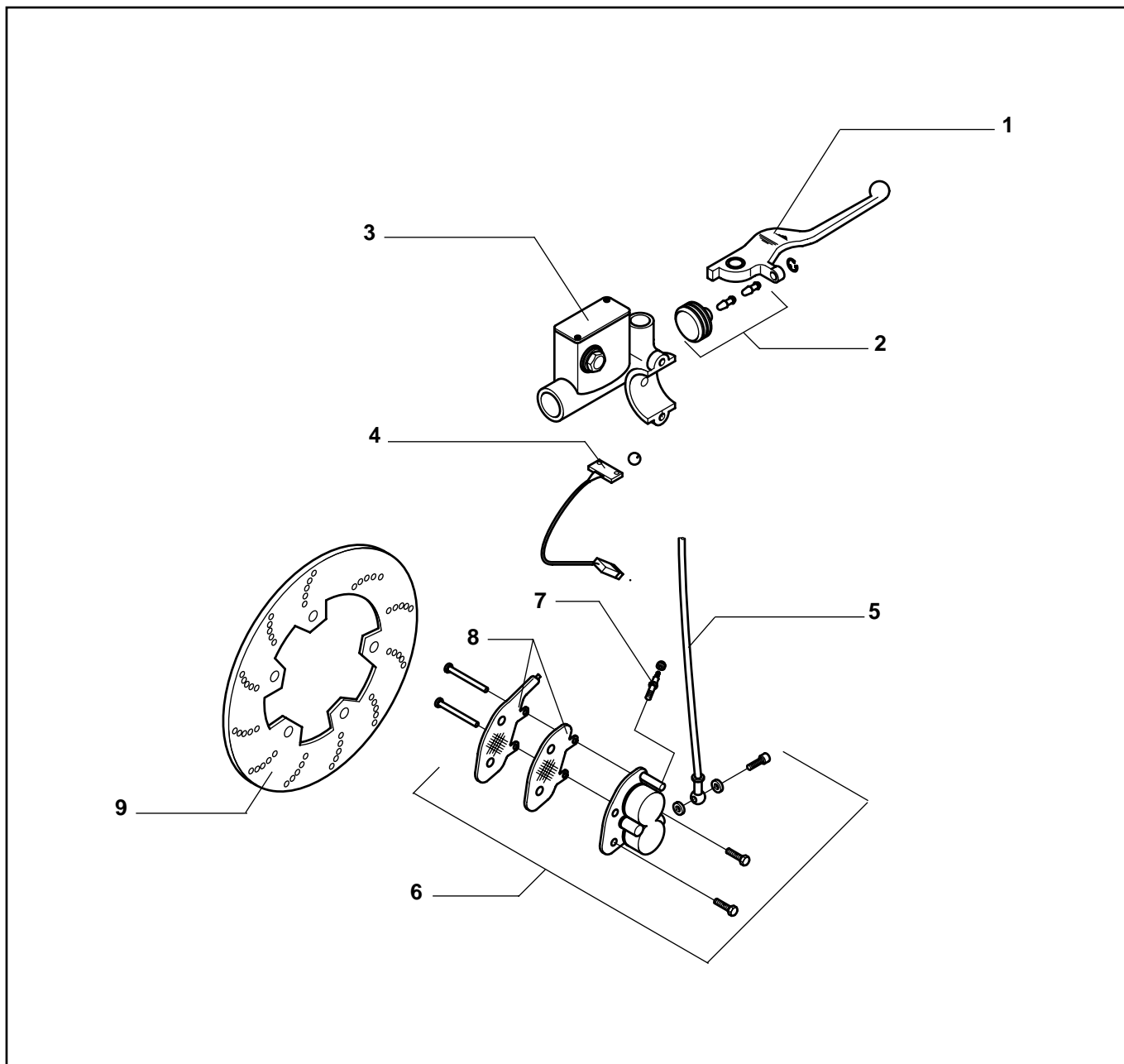

Key

- 1) Brake lever
- 2) Front brake master cylinder
- 3) Brake fluid reservoir
- 4) Brake light switch
- 5) Master cylinder-to-caliper brake line
- 6) Brake caliper
- 7) Bleeder screw
- 8) Brake pads
- 9) Brake disc

CHANGING THE FRONT BRAKE PADS

Read carefully (PRECAUTIONS AND GENERAL INFORMATION) and (CHECKING THE WEAR ON THE BRAKE PADS).

Position the motorcycle on the stand.
Using a hex wrench, loosen and remove the screws (1) that secure the pads to the front brake caliper.

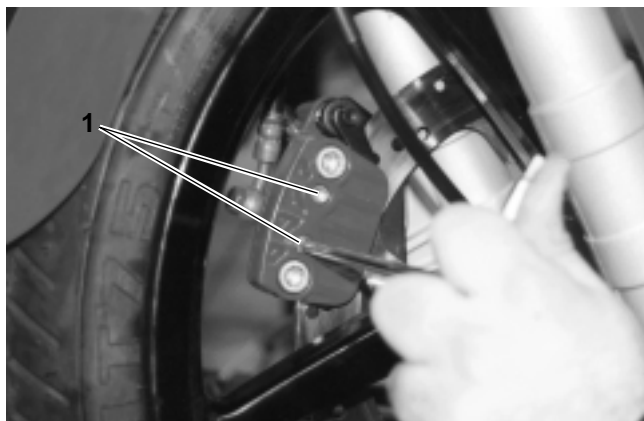

Loosen and remove the brake caliper screws (2).

**Torque setting for brake caliper screws (2):
22 Nm (2.2 kgm) [16.2 Ft-lb].**

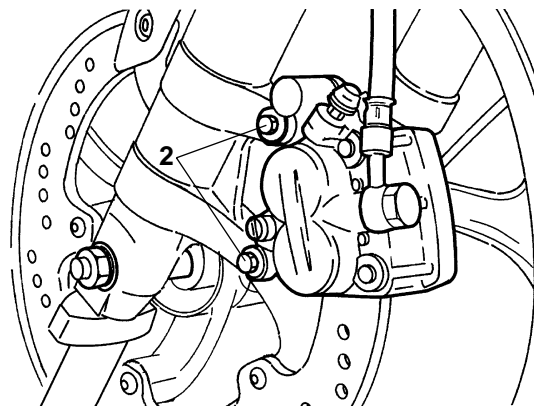

Remove the front brake caliper (3) and remove the pads manually (4).

▲ WARNING

Never touch the front brake lever after removing the brake caliper from the disc. If you do, the caliper pistons may be pushed down in their seats and brake fluid will be spilled.

Fit the 2 new pads, positioning them so that the holes are aligned with the holes in the caliper.

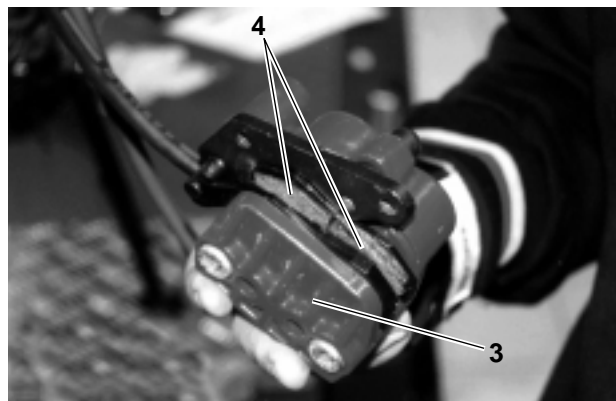

7

▲ WARNING

Always replace both pads and make sure they are correctly positioned in the caliper.

Reinsert the screws (1) that secure the pads to the front brake caliper (3), without tightening them.
Reassemble the front brake caliper, securing it with the screws (2).

Fully tighten the screws (1).

Check the brake fluid level (CHECKING AND TOPPING UP THE BRAKE FLUID).

REMOVING THE FRONT BRAKE MASTER CYLINDER

See (REMOVING THE FRONT BRAKE CONTROL).

REMOVING THE BRAKE DISC

Read carefully (PRECAUTIONS AND GENERAL INFORMATION).

Remove the front wheel (REMOVING THE COMPLETE FRONT WHEEL).

NOTE It is helpful to use an impact wrench to loosen the bolts (1), since they are locked in place using LOCTITE®.

Unscrew and remove the 5 brake disc bolts (1).

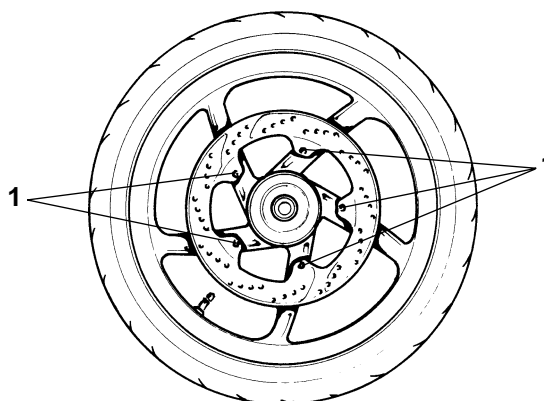

▲ WARNING

When refitting, apply LOCTITE® to the brake disc bolt (1) threads.

NOTE When refitting, screw in all the bolts (1) manually and then tighten them up in diagonal order, i.e.: A-B-C-D-E.

Remove the brake disc (2).

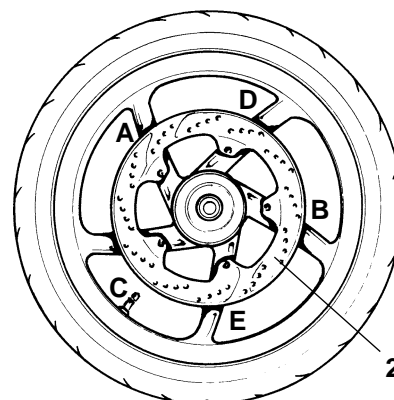

CHECKING THE BRAKE DISCS

NOTE Checking the brake disc for warpage must be done with the brake discs installed on the wheel. Using a dial gauge, check the maximum misalignment of the brake disc. If it exceeds the limits, it must be renewed (see REMOVING THE BRAKE DISC).

Check the wear of the disc by measuring the minimum thickness at various points around the disc with a micrometer.

If the disc is less than the specified minimum thickness at any point, renew the disc (see REMOVING THE BRAKE DISC).

Minimum disc thickness: 3.5 mm (0.14 in).

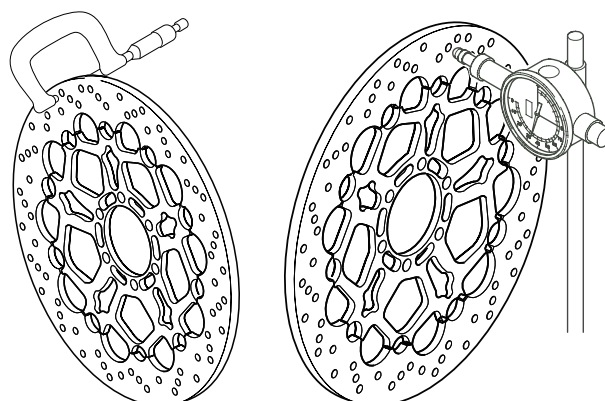

FRONT FORK

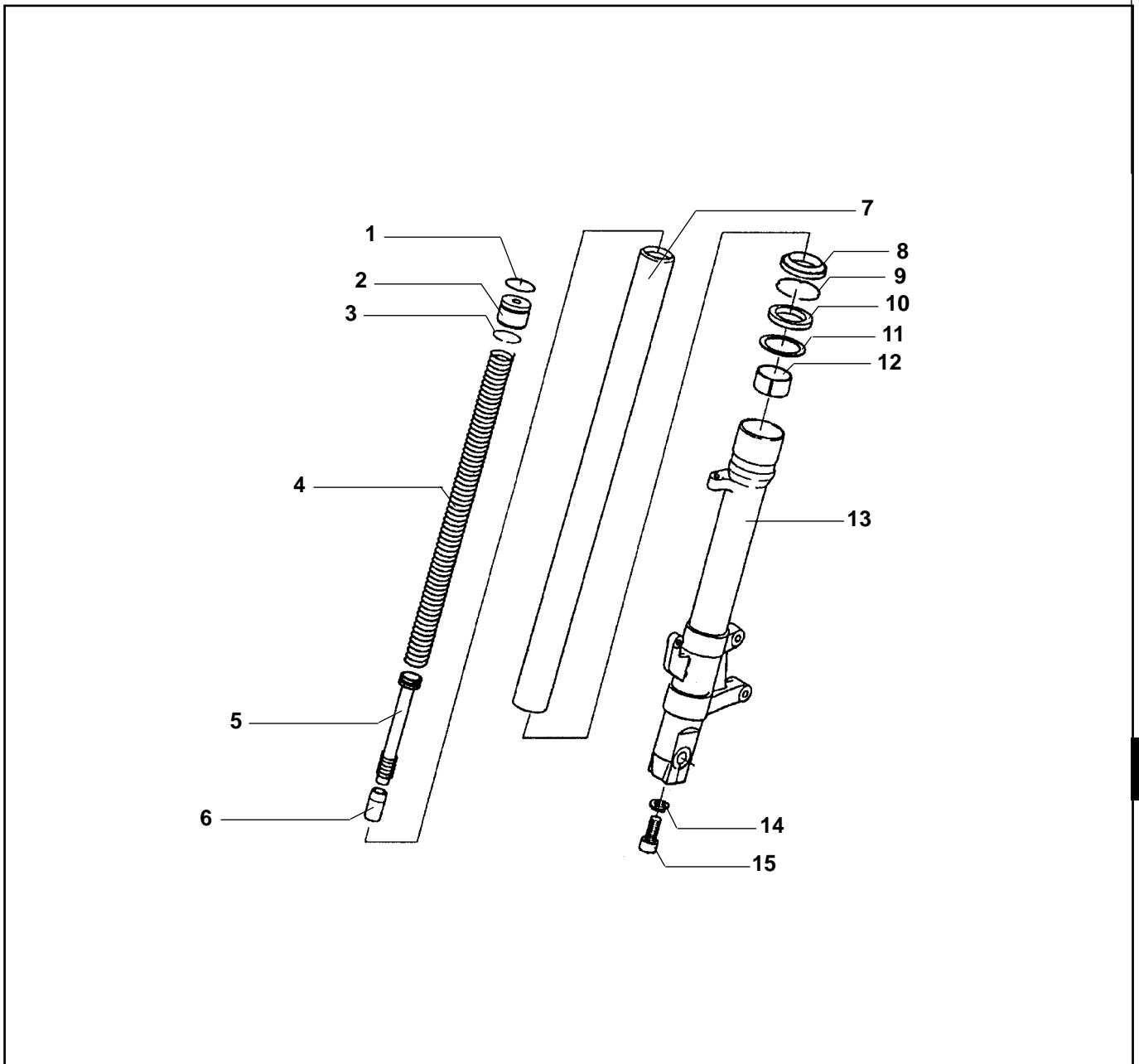

Key

- | | |
|---------------------|---------------------|
| 1) Circlip | 12) Sliding bush |
| 2) Tube plug | 13) Slider |
| 3) O-ring | 14) Seal washer |
| 4) Spring | 15) Oil drain screw |
| 5) Complete plunger | |
| 6) End bumper | |
| 7) Fork tube | |
| 8) Dust cover | |
| 9) Retainer ring | |
| 10) Ring seal | |
| 11) Cap | |

REMOVING THE FRONT FORK

Read carefully (PRECAUTIONS AND GENERAL INFORMATION).

Remove the fairings (REMOVING THE SIDE FAIRINGS).

Remove the saddle cowl (REMOVING THE LOWER FAIRING).

Remove the front wheel (REMOVE THE COMPLETE FRONT WHEEL).

Remove the front mudguard (REMOVING THE FRONT MUDGUARD).

▲ CAUTION

Always place a support of suitable size under the motorcycle before removing a fork, to stop the motorcycle from overturning.

NOTE Make sure there is enough space under the motorcycle to allow the front fork to be removed.

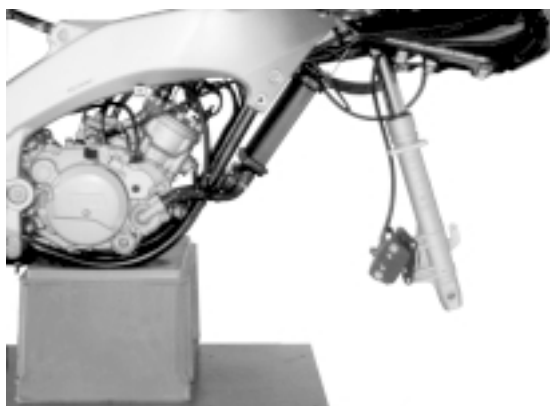

Loosen and remove the screw (1).

Torque setting for screw (1):
5 Nm (0.5 kgm) [3.7 Ft-lb].

Remove the fork tube plugs (2).

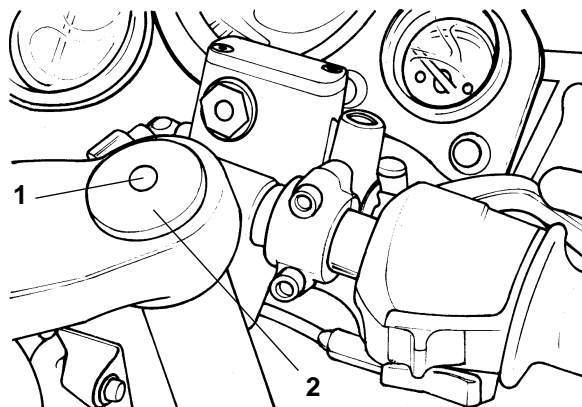

NOTE Before removing both the screws (3), support the fork to stop it from falling accidentally and being damaged.

Loosen the screws (3).

Withdraw the fork (4) through the top plate and the bottom plate of the fork head.

NOTE The front brake caliper must be removed from the slider before removing the fork.

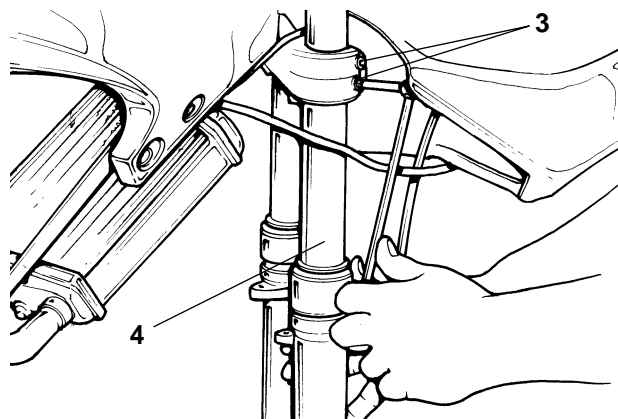

DISASSEMBLING THE FORK

Read carefully (PRECAUTIONS AND GENERAL INFORMATION) and (FORK OIL).

NOTE The right and left fork legs have the same internal components. The procedure described below refers to a single fork, but is applicable to both.

Remove the front fork (REMOVING THE FRONT FORK).

Clean the fork thoroughly.

NOTE Before proceeding with the operations described below, set up a vice with jaws (A) made of soft material, a screw (B) with M4 thread and a container to collect the oil, with a capacity greater than 350 cm³ (12 US fl oz).

▲ CAUTION

Take great care when disassembling the fork.

Loosen and remove the screw (1) that attaches the fork to the wheel axle.

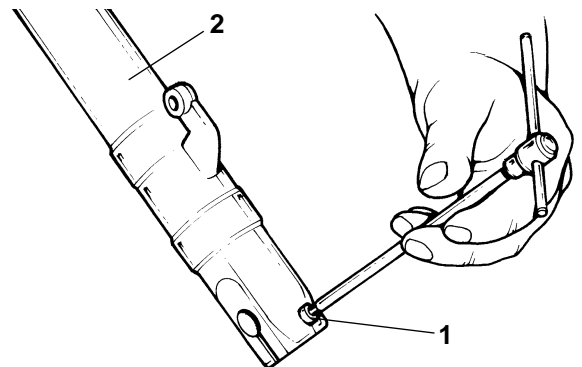

Position the fork (2) in a vice between the 2 jaws (A) and tighten the jaws moderately.

While depressing the tube plug (3) using a drift, pry out the circlip (4) with a screwdriver.

Remove the circlip (4) and release the fork plug (3).

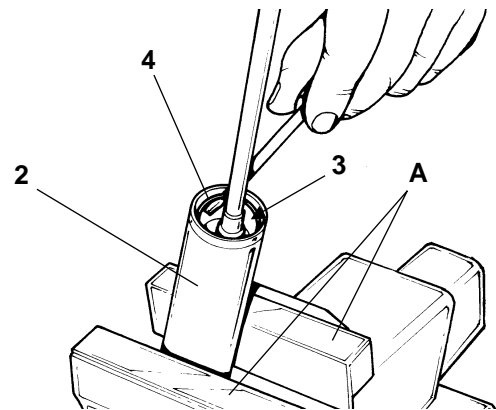

▲ CAUTION

The fork contains oil; do not turn it upside down or tilt it too much during the disassembly.

Screw the screw (B) into the tube plug (3) a couple of turns.

Remove the tube plug (3) and the O-rings (4) by pulling on the screw (B).

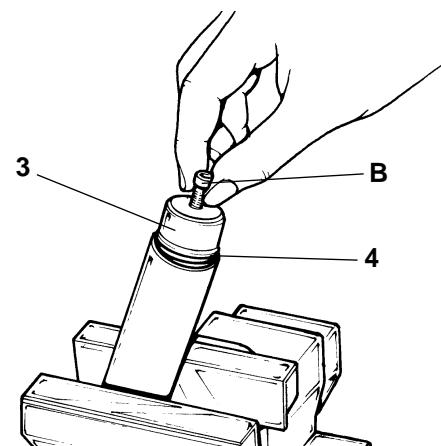

NOTE Before completely removing the spring (5), hold it just out of the tube (6) for a few seconds so that part of the oil runs down into the tube.

Remove the spring (5).

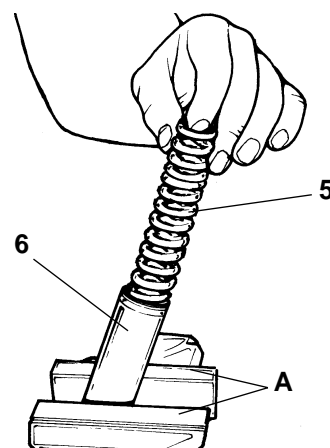

Turn the fork upside down and pour the oil out into a container (7). This takes several seconds, be patient.

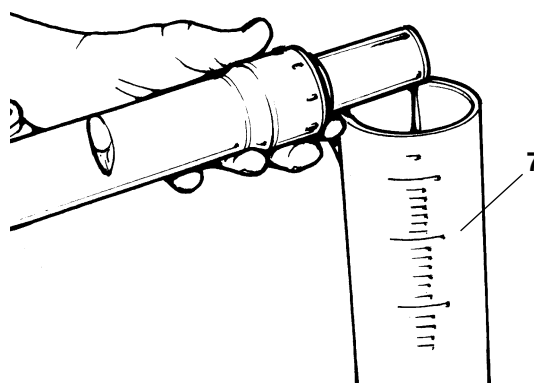

Place the fork in the vice between the 2 jaws (A), gripping the slider. Using a socket wrench (8), loosen and remove the plunger retainer screw (9). Remove the copper washer (10).

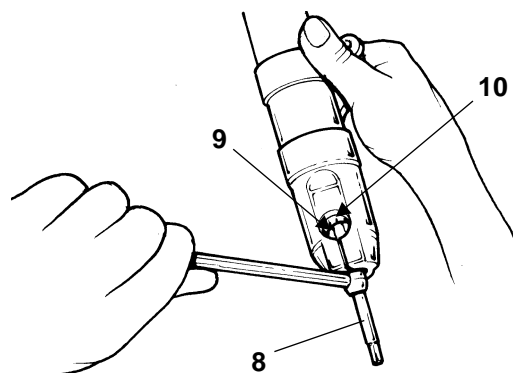

Remove the dust cover seal (11) by prying it off evenly with a screwdriver. Be careful not to distort the slider or to scratch the fork tube.

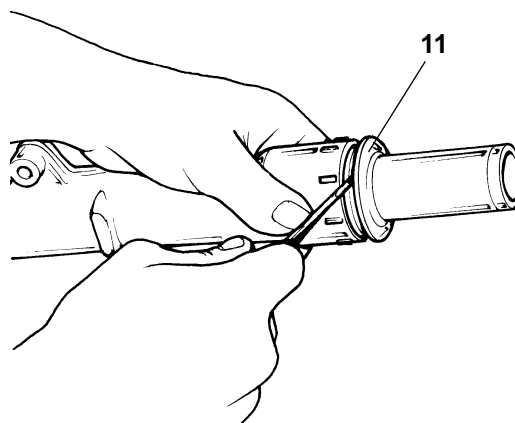

NOTE The following operation requires the application of considerable force.

Withdraw the fork tube (6) complete with plunger (12) end bumper (13).

▲ CAUTION

Do not disassemble the plunger (3).

Remove the dust cover (11) (see previous figure) from the tube (6).

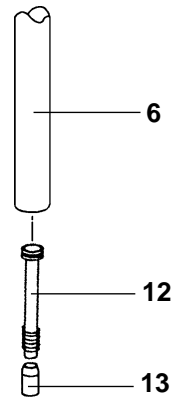

Using a blade screwdriver, remove the retainer ring (14) by prying in the notch formed in the ring (15).

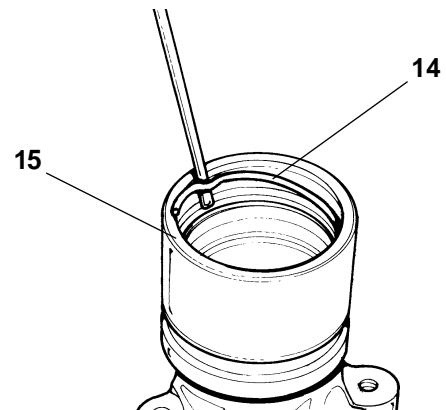

NOTE Reposition the slider in the vice between the 2 jaws (A).

Place a piece of rubber (B) on the rim of the slider to stop damaging it in the next operation.

Using a blade screwdriver, remove the oil seal (16) by prying at different points around the circumference.

▲ CAUTION

Be extra careful to avoid damaging the upper lip of the slider. It is made of relatively soft aluminum and can easily be destroyed if you are not careful.

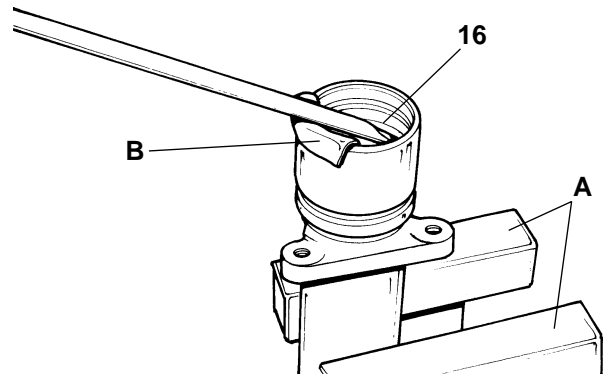

7

Remove the cap (17) and then the sliding bush (18) from the slider.

▲ WARNING

Wash the components in clean, fire-proof solvent.

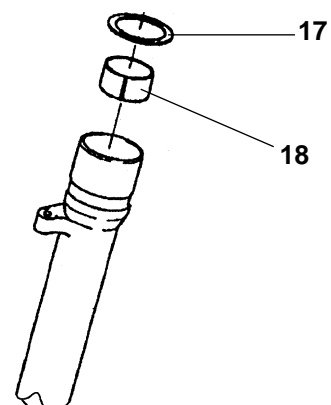

CHECKING THE COMPONENTS

TUBE

Check for scoring and/or scratches on the slide surface. Very slight scoring can be removed with emery cloth or 600 wet or dry paper, wetted with fire-proof solvent. Move the paper up and down the tube, do not place the tube in a lathe to polish it.

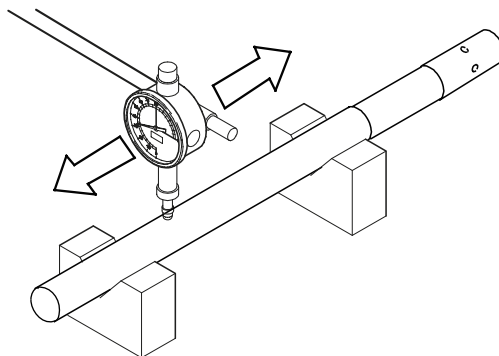

⚠ WARNING

NEVER straighten and re-use a bent tube, as the structure will have been weakened, making the motorcycle dangerous to use. Failure to observe this warning can lead to a fork failure, which will inevitably lead to a serious crash with subsequent serious injury or even death.

SLIDER

Check for signs of damage and/or cracks; if any are found, replace the slider.

SPRING

Check the condition of the following components:
sliding bush (1);
cap (2);
plunger (3).

Replace the component with a new one if there are any signs of excessive wear or damage.

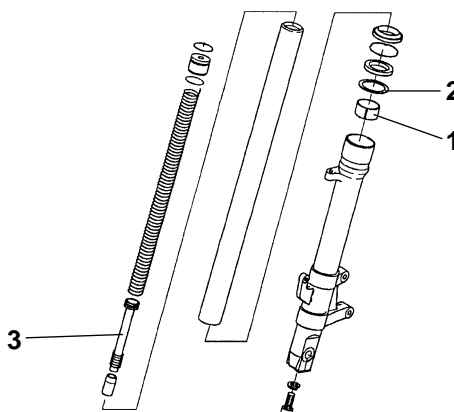

▲ WARNING

Remove any impurities from the bushes, being careful not to scratch the surfaces.

Replace the following parts with new ones:
oil seal (4);
dust seal (5);
the 2 O-rings on the tube plug (6).

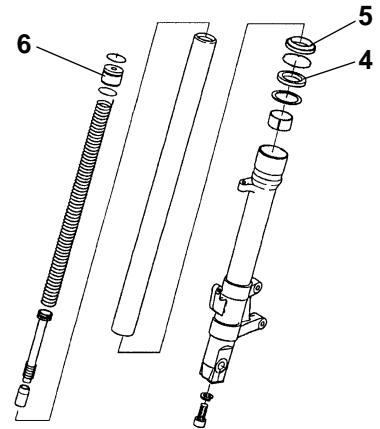
**REFITTING THE FORK**

Read carefully (PRECAUTIONS AND GENERAL INFORMATION).

▲ WARNING

When refitting, take great care and check that the sliding surfaces are in perfect condition (i.e. no signs of wear, scoring, etc.), replacing any components with new ones when necessary. Take great care to ensure that no foreign material gets into the parts.

Do not re-use old oil.

Always replace the seals with new ones.

The reassembly must be done very carefully.

7

Apply a film of fork oil to the seals and bushes before fitting them (see LUBRICANT CHART).

Place the slider (1) between the vice jaws (made of a soft material: aluminum), with the open end pointing up.

Fit the sliding bush (2) into the slider (1).

Next, insert the cap (3).

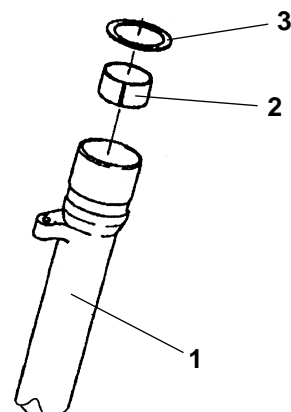

▲ CAUTION

Use a plastic-headed mallet (4) for the following operations.

Using a drift of suitable diameter (5), fit the new oil seal into the slider (1), ensuring that it is fully seated by tapping lightly several times with a plastic hammer (4).

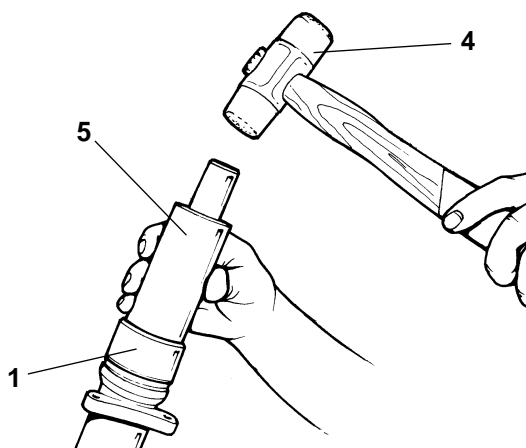

Press the retainer ring (6) into the slider until you feel it click into its groove.

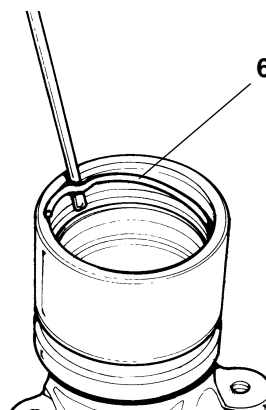

Fit a new seal washer (7) and screw in and tighten the screw (8).

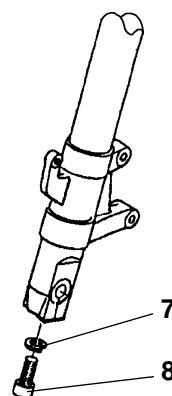
**▲ CAUTION**

Do not allow the plunger to fall in the following operations.

Insert the complete plunger into the tube (9) and put a new dust seal (10) in position. Insert the tube into the slider (1), pushing it right down until you feel it click into place. Tighten the screw (8).

NOTE The tube (9) must slide freely in the slider (1), with no sticking.

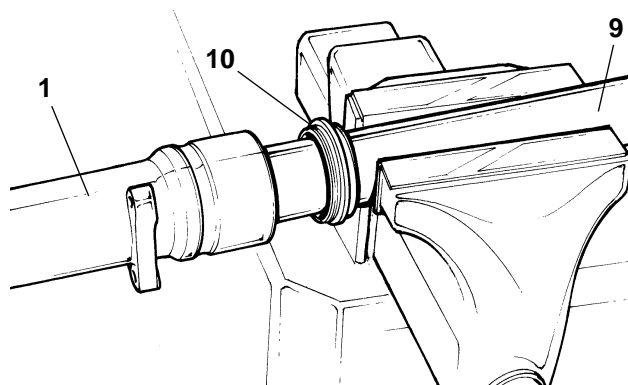

With the tube fully extended, fit the dust cover (10) on to the slider (1) (see pervious figure).

Hold the fork (11) in a vertical position.

Pour fork oil (see LUBRICANT CHART) into the fork, until it reaches the correct level.

Quantity of oil: $285 \pm 2 \text{ cm}^3$ ($10 \pm 0.7 \text{ US fl oz}$).

Oil level: 140 mm (5.5 in) (from edge of tube).

NOTE The fork (11) must be perfectly vertical when measuring the oil level. The oil level must be perfectly equal in both legs.

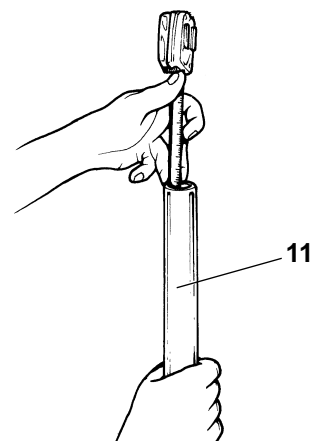

With the tube (9) still extended, insert the spring (12).

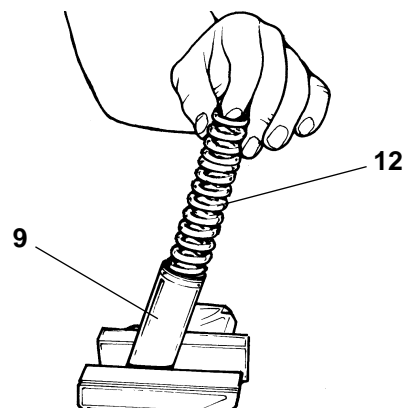

Place the fork (11) in the vice with the soft jaws (A), tightening the vice only moderately.

NOTE Fit two new O-rings on the tube plug (13). Press down the tube plug (13) and fit the circlip (14). Gradually release the tube plug until you feel the circlip (14) click into place in the groove in the tube (9).

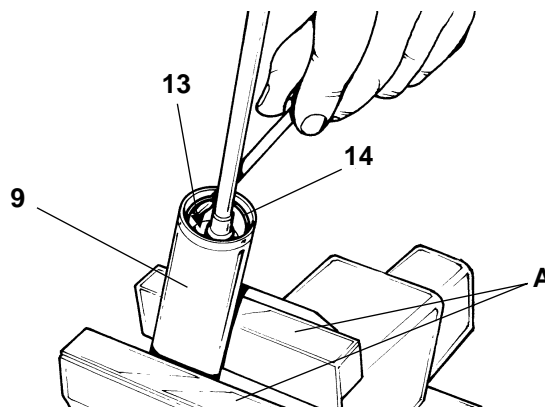

STEERING

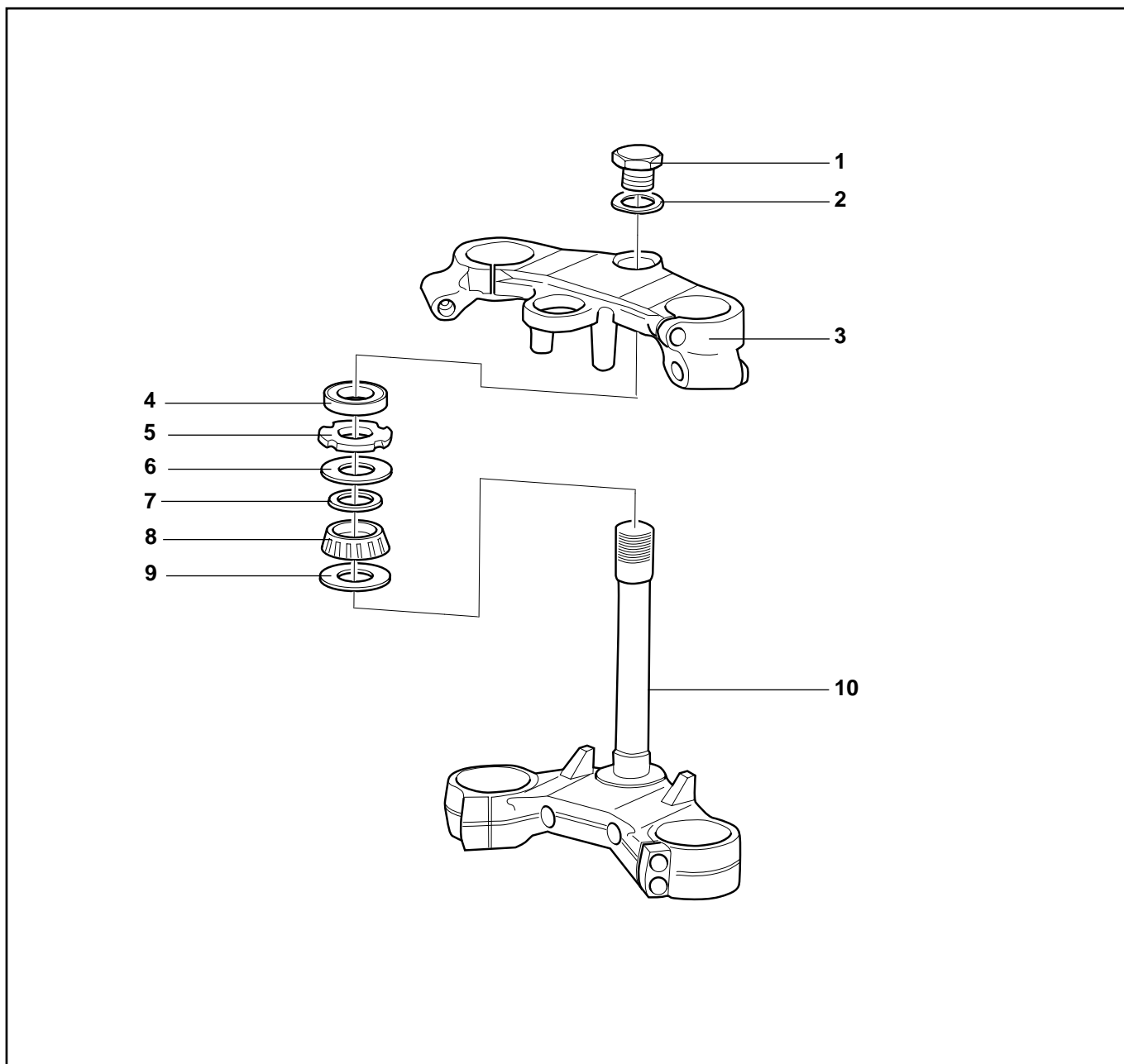

Key

- 1) Steering stem tube
- 2) Washer
- 3) Upper plate
- 4) Ball bearing
- 5) Ring nut
- 6) Retainer ring
- 7) Washer
- 8) Roller bearing
- 9) Washer
- 10) Lower plate with steering stem

REMOVING THE STEERING

Read carefully (PRECAUTIONS AND GENERAL INFORMATION) and (STEERING).

Position the motorcycle on the rear stand **OPT** on a lift platform (POSITIONING THE MOTORCYCLE ON THE REAR STAND **OPT**).

Remove the fairings (REMOVING THE SIDE FAIRINGS).

Remove the saddle cowl (REMOVING THE LOWER FAIRING).

Remove the exhaust pipe (REMOVING THE EXHAUST PIPE).

Remove the front fairing (REMOVING THE FRONT FAIRING).

Remove the front braking system (REMOVING THE FRONT BRAKE CONTROL).

Loosen and withdraw the speedometer cable (1) to allow the removal of the front fork.

▲ CAUTION

Because of the weight of the front fork, the following operations require a second person. Agree beforehand on the procedure. Proceed with great care during the removal. Support the front fork to stop it from falling accidentally.

NOTE Removal of the front fork is greatly facilitated by the removal of the front wheel and fender (or mudguard) (see REMOVING THE FRONT WHEEL, REMOVING THE FRONT MUDGUARD). Then, the two front fork tube assemblies, along with the fork head, may be easily removed as a unit.

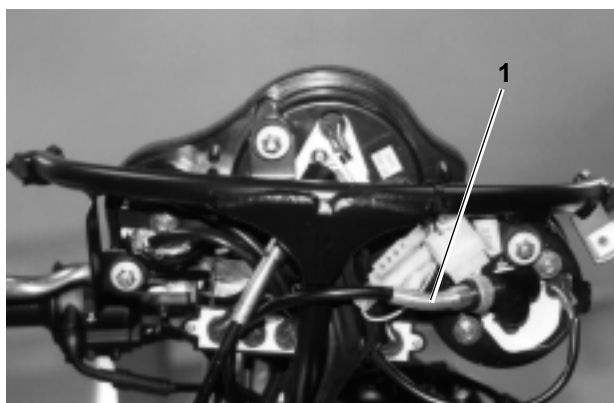

NOTE Place a stand of suitable height and strength under the engine cradle, positioning it so the front forks extend over the front end of the platform.

Strap the motorcycle to the platform to prevent it from tipping over while the fork is removed.

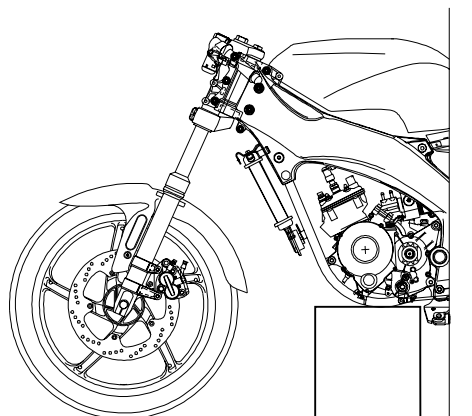

7

Remove the front wheel along with the front wheel (REMOVING THE FRONT WHEEL).

Remove the front mudguard, following the procedure described in (ADJUSTING THE PLAY ON THE BEARINGS).

Loosen and remove the adjustor ring nut (1).
 Remove the roller bearing (3) and the retainer ring (4)
 from the steering stem (2).
 Remove the ring seal (5) and washer (6).
 Using a bearing puller, remove the bearing (7) from its
 seat in the frame.

Clamp the lower plate and steering stem (2) in a vice
 with soft jaws.

Using a bearing extractor, or a pair of pry bars, gently
 pull the bearing (3) and retainer ring (4) from the
 steering stem. Take great care not to damage the
 stem. Pry only on the inner race of the bearing, never
 on the roller cage.

▲ CAUTION

**When refitting the bearings, use a hollow drift of
 the same diameter as the inner race, when you are
 installing bearings on the steering stem, and the
 outer race, when you are installing bearings in the
 fork head. Never allow the drift to contact the
 rollers or the cage. Make sure that both the bear-
 ing inner and outer races are drifted fully home.
 Before installation, carefully wash all components
 with clean, fire-proof solvent. Lubricate the bear-
 ing races before you install them.**

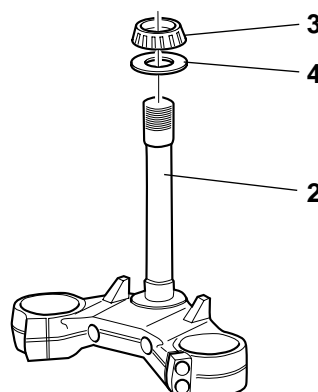
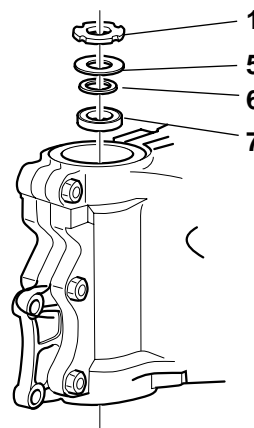

CHECKING THE COMPONENTS

▲ WARNING

**Check the condition of all the components, espe-
 cially the ones listed below.**

BEARINGS AND GASKETS

See (CHECKING THE COMPONENTS).

REFITTING THE STEERING

NOTE For reassembly, the motorcycle and front fork must be positioned as for disassembly. Follow the disassembly procedure in reverse.

Apply a thin film of grease along the whole of the stem (1) and to the roller bearings (2).
Hand-tighten the ring nut (3) until it just makes contact, and then tighten another 1/4 turn.

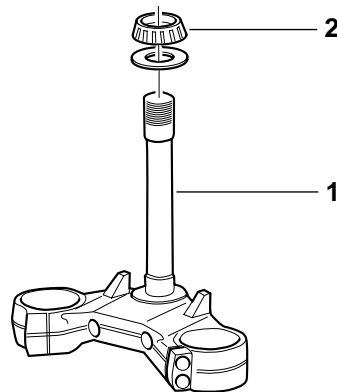

Reduce the play of the bearings (see ADJUSTING THE PLAY ON THE BEARINGS).

Turn the handlebars to check that the cables and hoses are not fouled, twisted, tangled or stretched when the handlebars are rotated from lock to lock.

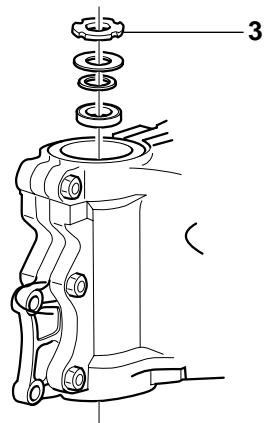

REAR WHEEL

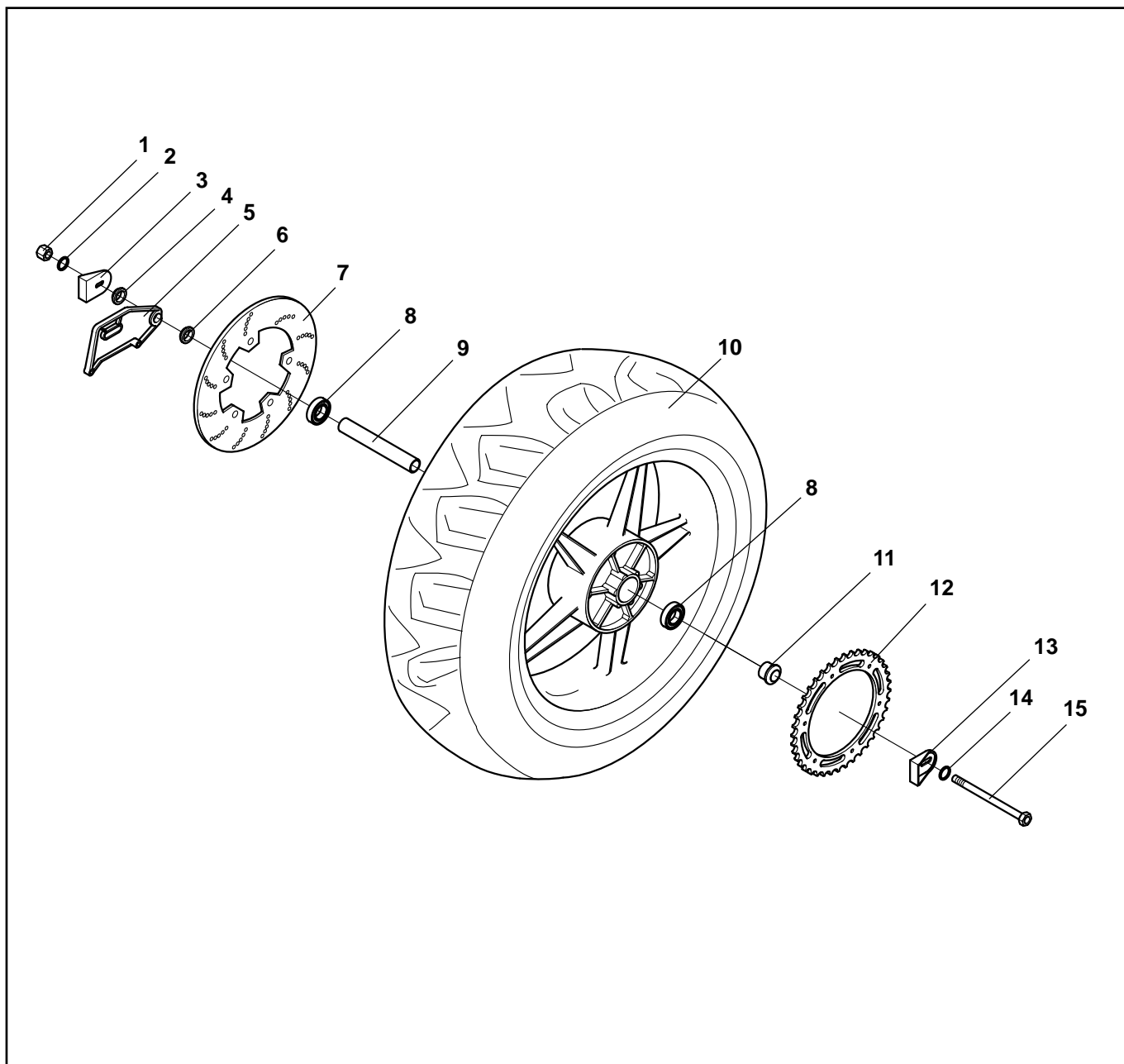

Key

- | | |
|---------------------------|-------------------|
| 1) Nut | 12) Rear sprocket |
| 2) Washer | 13) Chain guide |
| 3) Chain guide | 14) Washer |
| 4) Spacer | 15) Axle |
| 5) Caliper mounting plate | |
| 6) Spacer | |
| 7) Brake disc | |
| 8) Bearings | |
| 9) Spacer | |
| 10) Complete wheel | |
| 11) Shim | |

REMOVING THE COMPLETE REAR WHEEL

Read carefully (SERVICING SCHEDULE).

▲ WARNING

Before proceeding, allow the engine and exhaust to cool down to ambient temperature, to avoid possible burns.

While disassembling and reassembling the wheel, pay extra care not to damage the brake lines, discs or pads.

NOTE The correct rear stand must be used for removing the rear wheel **OPT.**

DISASSEMBLY

Position the motorcycle on the appropriate rear support stand. (POSITIONING THE MOTORCYCLE ON THE REAR SUPPORT STAND **OPT.**)

Rear stand: 8705021.

Prevent the axle (1) from rotating with the appropriate Allen wrench.

Wheel nut (2) tightening torque:
59 Ft-lb (8 kgm) [80 Nm].

Remove the nut (2) and washer.

Place a support (3) under the tire, in such a way as to keep the wheel in its position after loosening it.

Remove the axle (1) from the right side.

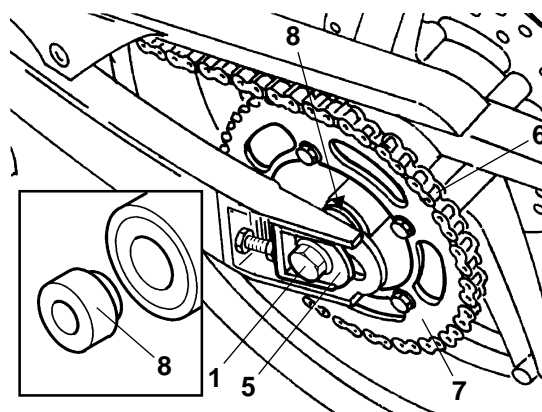

NOTE Observe the arrangement of the right (4) and left (5) chain tensioners in order to be able to reassemble them correctly. Remove the right (4) and left (5) chain tensioners. Move the chain off the sprocket and lay it down outside the sprocket.

NOTE Lower the drive chain (6) outside the crown gear (7).

▲ WARNING

Take extra care to ensure that your fingers are not caught between the chain and the rear sprocket. Wear heavy work gloves when performing this operation. If your fingers become entangled in the chain and rear sprocket, you will amputate a finger or suffer other serious injury.

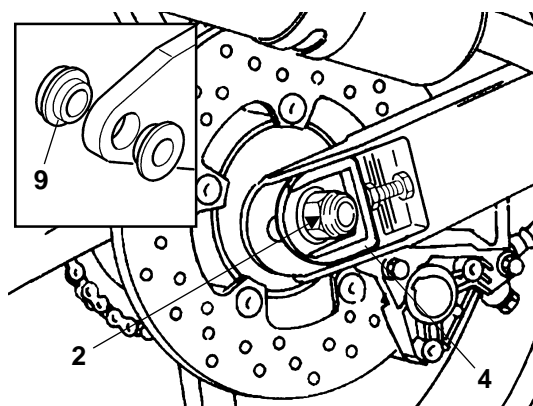

Turn the wheel forward slightly, release the drive chain (6) from the rear sprocket (7).

Remove the wheel from the swing arm from behind, carefully removing the disc from the brake caliper.

NOTE Observe the arrangement of the spacers (8) and (9) in order to be able to reassemble them correctly.

Remove the left spacers (8).

Remove the right spacers (9).

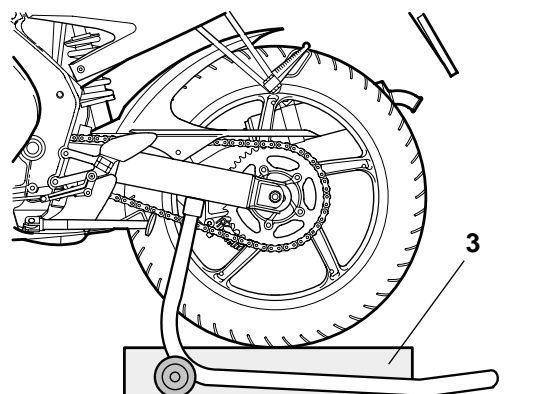

▲ CAUTION

Never touch the rear brake pedal after removing the wheel. If you do, the caliper pistons may be pushed out of their seats, and brake fluid will be spilled.

Should you accidentally do this, take your motorcycle to your Local *aprilia* Dealer who will know how to repair this damage.

DISASSEMBLING THE REAR WHEEL

Read carefully (PRECAUTIONS AND GENERAL INFORMATION).

Remove the wheel (REMOVING THE COMPLETE REAR WHEEL).

Follow the procedure described in the (DISASSEMBLING THE FRONT WHEEL) chapter.

In addition, disassemble the crown gear (CROWN GEAR).

CHECKING THE COMPONENTS

See the (CHECKING THE COMPONENTS) chapter.

CROWN GEAR

Check the state of the teeth on the rear sprocket (1) and front sprocket.

If there are signs of excessive wear, replace the rear sprocket, front sprocket and chain (REMOVING THE DRIVE CHAIN).

▲ CAUTION

All three parts must be replaced together, to avoid the premature wear of the new components.

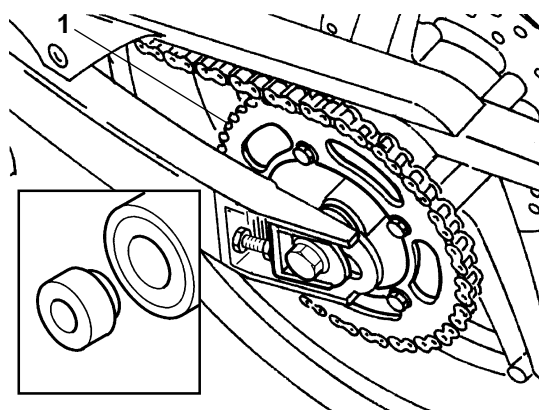

REASSEMBLY REAR WHEEL

Read carefully (SERVICING SCHEDULE).

Apply a thin film of grease to the outer seals of the rear wheel hub.

▲ CAUTION

The spacers have different diameters: do not mix them up and take care to position them correctly.

Insert the left (1) and right (2) spacers in their seals on the wheel hub.

Install the spacer (4) in its correct position, if it has fallen out of the torque plate seat (3).

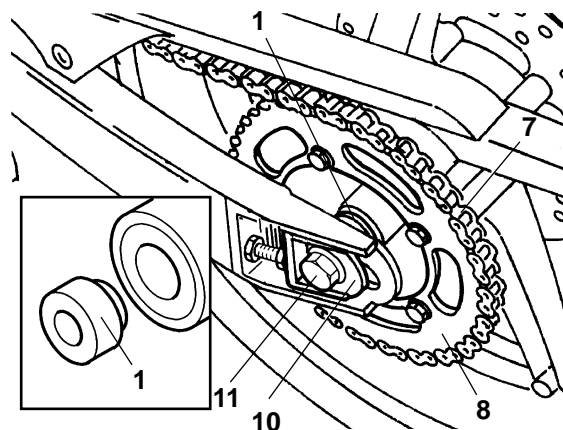

▲ CAUTION

Before proceeding with the reassembly, make sure that the torque plate (3) of the brake caliper (4) is positioned correctly; the plate slot must be inserted in the appropriate stop pin (5) in the inner part of the right side of the swinging arm. Insert the disc in the brake caliper carefully.

Position the wheel centrally in the swinging arm (6).

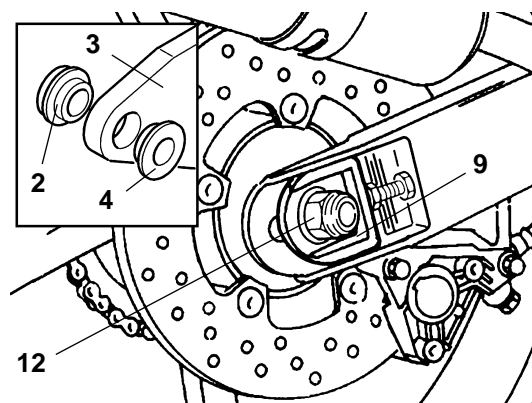

▲ WARNING

Take extra care to ensure that your fingers are not caught between the chain and the rear sprocket. Wear heavy work gloves when performing this operation. If your fingers become entangled in the chain and rear sprocket, you will amputate a finger or suffer other serious injury.

Move the wheel forward as far as possible in order to install the chain (7) on the sprocket (8).

Pull the rear wheel backwards until the bearing holes are lined up with the holes in the swinging arm.

Rotate the torque plate (3), complete with brake caliper (4), with the stop pin (5) in proper position until it is appropriately aligned with the holes in the swing arm.

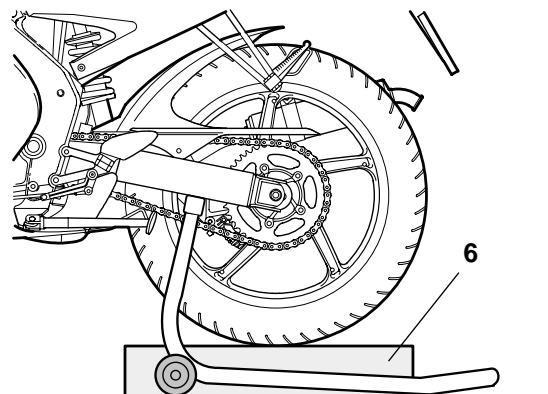

Install the right (9) and left (10) chain tighteners in their seats on the swing arm.

Lightly grease the outside of the axle (11).

Install the axle (11) completely through the wheel from the left side.

NOTE Ensure that the axle (1) is pushed all the way home with the head in the appropriate seat on the left chain tightener (10).

Install the washer and tighten the nut (12) finger tight. Check the chain tension, (DRIVE CHAIN).

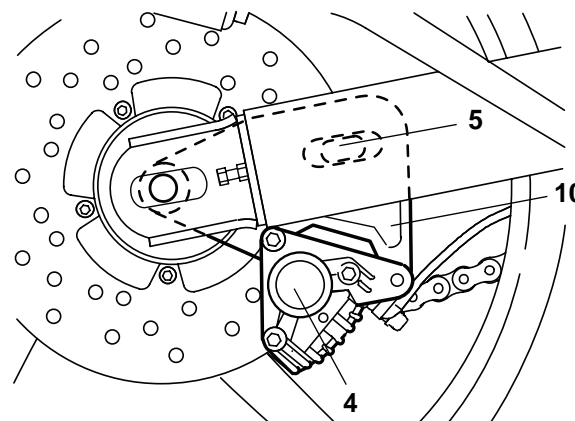

Tighten the nut (1).

**Wheel nut (1) tightening torque:
59 Ft-lb (8 kgm) [80 Nm].**

▲ WARNING

After servicing the brakes, always check them for function. If the stroke of the lever or pedal is excessive, or if you detect that the effectiveness of the brakes is reduced in any way, have your motorcycle serviced by your Local **aprilia** Dealer. It may be necessary to have your dealer bleed the system, or there may be some other problem with the brake system.

Never ride your motorcycle in traffic immediately after servicing the brakes.

Always apply the brake pedal or lever several times before riding your motorcycle. Then, try your motorcycle in a parking lot or other safe area with little traffic to ensure that the brakes are working properly. Failure to observe this warning can lead to a serious accident with subsequent serious injury or death.

Check the wheel centering.

Have the tightening torques, centering and balancing of the wheel checked by your Local **aprilia** Dealer. These are critical safety operations, and failure to observe this warning could lead to an upset with subsequent serious injury or death.

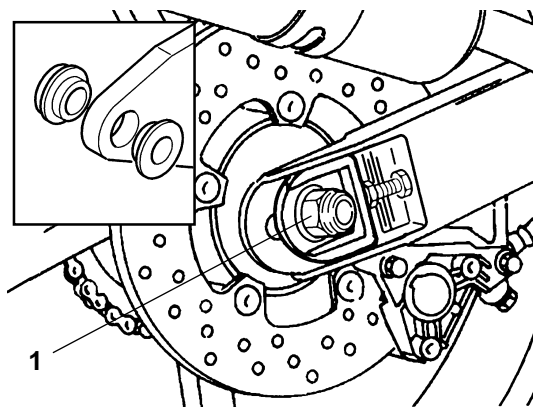

REAR BRAKE

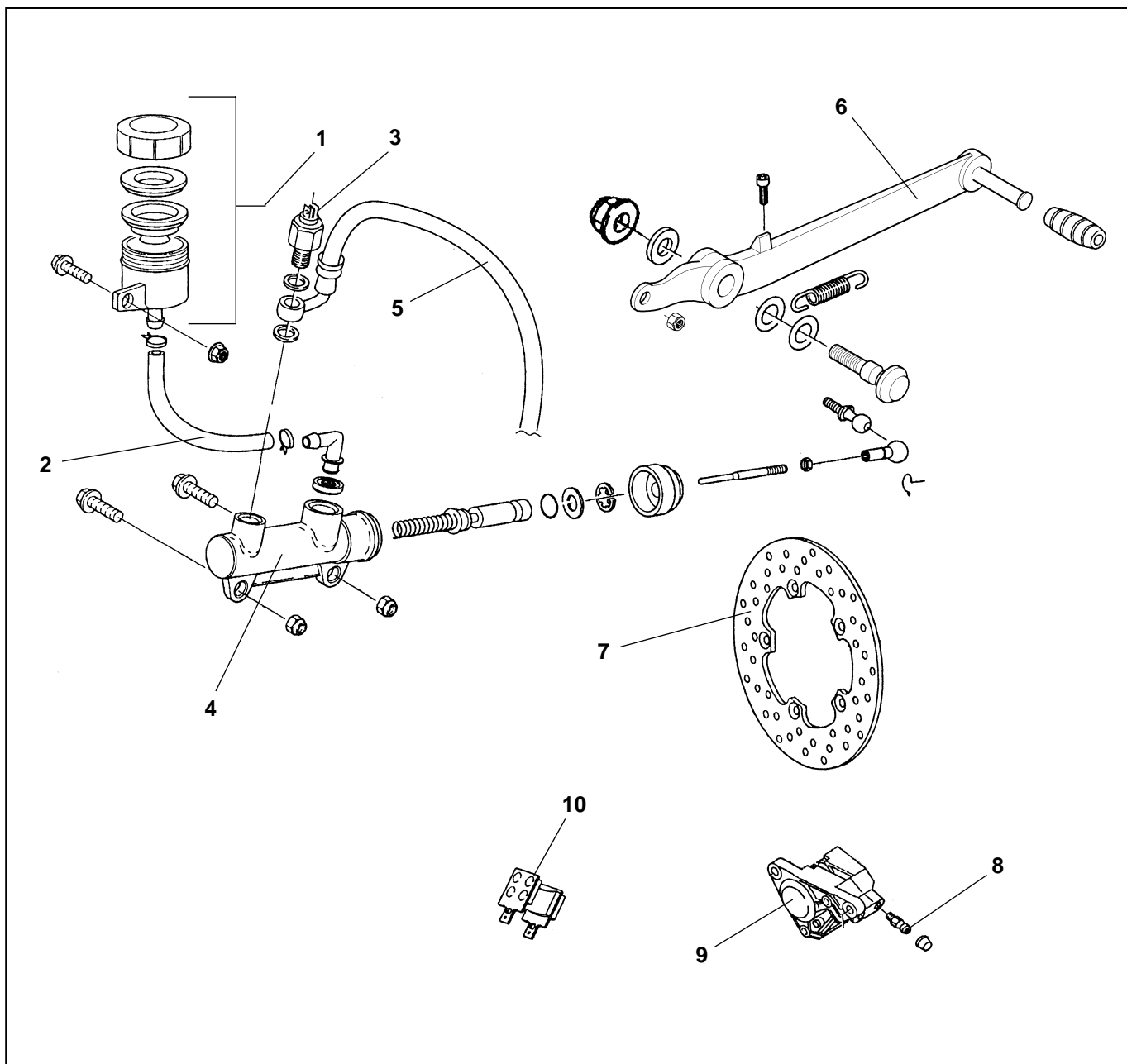

Key

- 1) Brake fluid reservoir
- 2) Reservoir-to-master cylinder brake fluid tube
- 3) Brake light switch
- 4) Brake master cylinder
- 5) Master cylinder-to-caliper brake fluid tube
- 6) Brake pedal
- 7) Brake disc
- 8) Bleed valve
- 9) Brake caliper
- 10) Brake pad

CHANGING THE REAR BRAKE PADS

Read carefully (**PRECAUTIONS AND GENERAL INFORMATION**) and (**CHECKING THE WEAR ON THE BRAKE PADS**).

Position the motorcycle on the stand.
Remove the brake caliper cover (1).

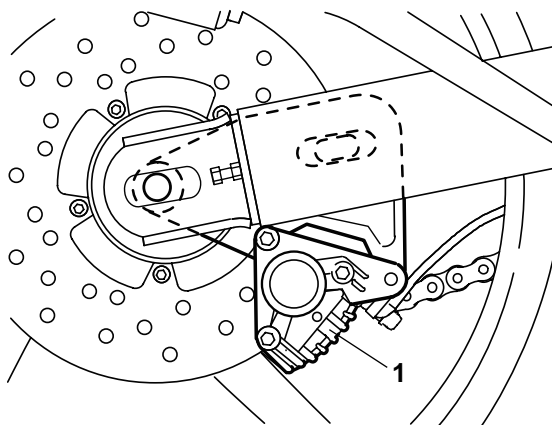

NOTE Before withdrawing the pin (3), check the position of the safety spring (4); it must be positioned in the same way when refitted, with the arrow stamped on its back pointing down.

Remove the retainer ring (2).
Withdraw the pin (3) and take off the safety spring (4).
Take out the 2 pads (5).

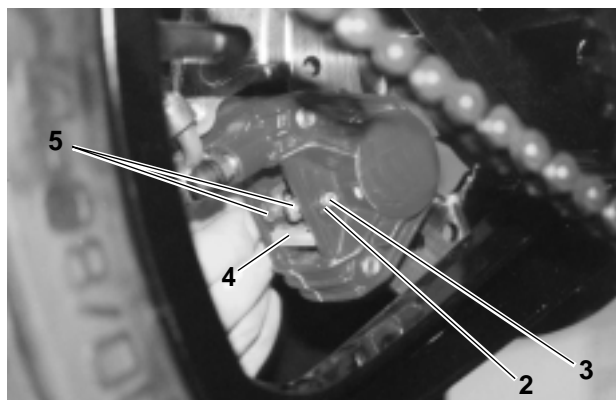

NOTE Do not pull on the brake lever after removing the pads, as this could push caliper pistons out of their housings and make the brake fluid leak out.

Insert 2 new pads, positioning them so that are aligned with the holes in the caliper.

NOTE Always replace both pads and make sure they are positioned correctly inside the caliper.

Position the safety spring (4).
Keeping the safety spring (4) pressed down in the center, insert the pin (3) so that it goes above the spring.
Position the retainer ring (2).
Position the brake caliper cover (1).
Check the brake fluid level (**CHECKING AND TOPPING UP THE BRAKE FLUID**).

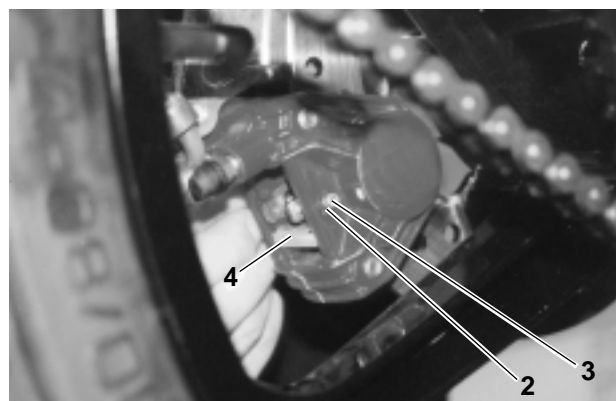

REMOVING THE REAR BRAKE DISC

Read carefully (PRECAUTIONS AND GENERAL INFORMATION).

Remove the rear wheel (REMOVING THE COMPLETE REAR WHEEL).

NOTE It is helpful to use an impact wrench to loosen the bolts (1), since they are locked in place using LOCTITE®.

Unscrew and remove the 5 brake disc bolts (1).

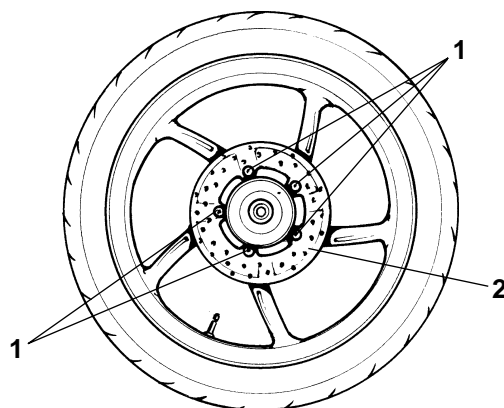

▲ WARNING

When refitting, apply LOCTITE® to the brake disc bolt threads.

NOTE When refitting, hand-tighten the bolts and then torque them in diagonal order, i.e.: A-B-C-D-E.

Remove the brake disc (2).

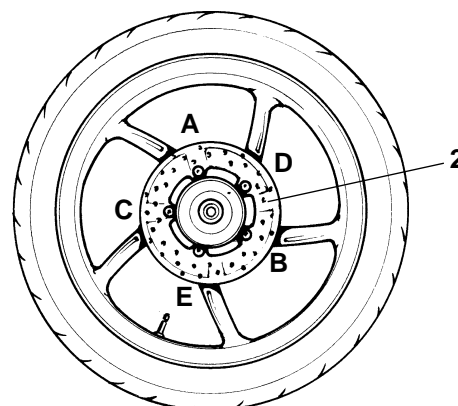

CHECKING THE BRAKE DISC

NOTE Checking the brake disc for warpage must be done with the brake discs installed on the wheel. Using a dial gauge, check the maximum misalignment of the brake disc. If it exceeds the limits, it must be renewed (see REMOVING THE BRAKE DISC).

Check the wear of the disc by measuring the minimum thickness at various points around the disc with a micrometer. If the disc is less than the specified minimum thickness at any point, renew the disc (see REMOVING THE BRAKE DISC).

Minimum disc thickness: 3.5 mm (0.14 in).

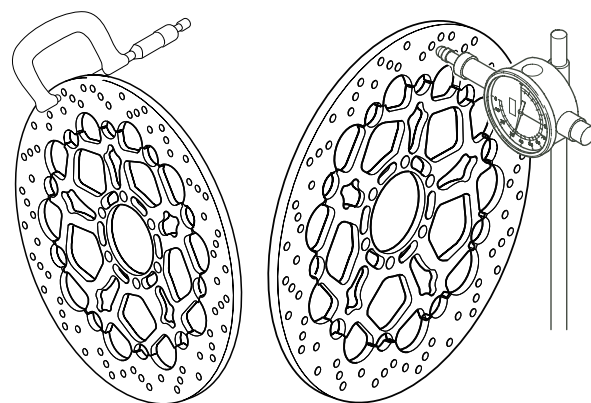

7

REMOVING THE REAR BRAKE MASTER CYLINDER

Read carefully (PRECAUTIONS AND GENERAL INFORMATION).

Position the motorcycle on the stand.

Drain the brake fluid, as described in (CHANGING THE REAR BRAKE FLUID).

When the reservoir is empty, unscrew and remove the brake light switch (1), move the tube (2) and remove the seal washers (3).

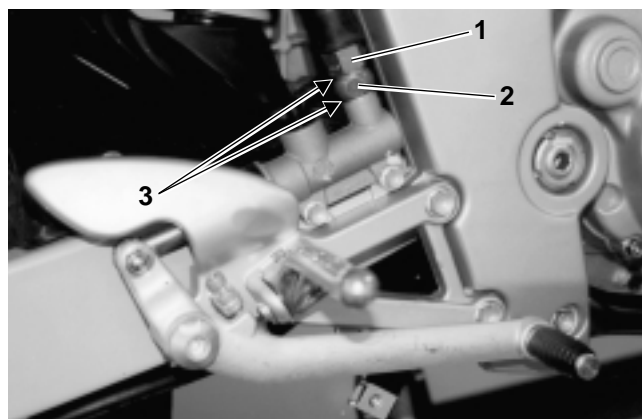

Loosen and move the tube clamp (4).
Withdraw the tube (5) and remove the 2 screws (6).

Torque setting for screws (6):
10 Nm (1.0 kgm) [7.4 Ft-lb].

Remove the master cylinder (7), taking it out from the front.

NOTE When refitting, refill with brake fluid (CHECKING AND TOPPING UP THE REAR BRAKE FLUID) and bleed the air from the brake circuit (BLEEDING THE BRAKE SYSTEMS).

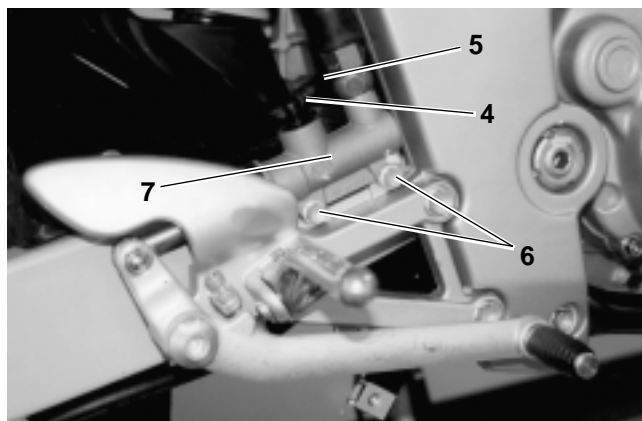

REMOVING THE REAR SUSPENSION

Read carefully (PRECAUTIONS AND GENERAL INFORMATION).

Remove the rear mudguard (REMOVING THE REAR MUDGUARD).

Remove the pillar cover (REMOVING THE PILLAR COVER).

NOTE Position a support between the rear wheel and the lower part of the frame.

Loosen and remove the nut (1) and push out the screw (2) partially.

Torque setting for nut (1):
48 Nm (4.8 kgm) [35.4 Ft-lb].

Remove the screw (2) and pull the rear suspension out from the front; remove the washer.
Remove the support from between the rear wheel and the lower part of the frame, so that the wheel rests on the frame.

Loosen and remove the nut (3) and push out the screw (2) partially.

Torque setting for screw (2):
48 Nm (4.8 kgm) [35.4 Ft-lb].

Remove the screw (2) and take off the washer.
Grasp the suspension (4) and remove it from under the motorcycle.

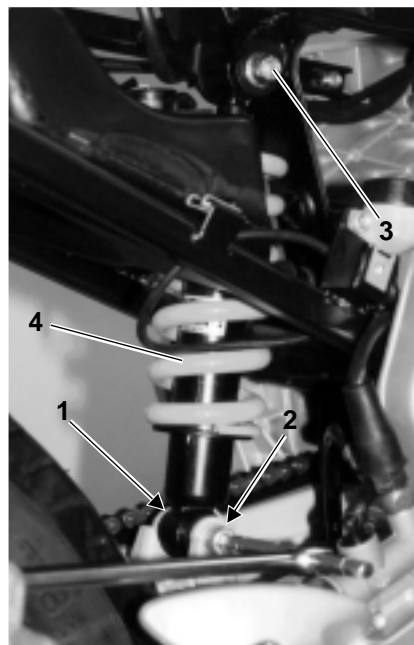

Remove the 4 T-bushes (5) and withdraw the 2 silent-blocks (6).

NOTE Wash all components with fire-proof solvent.

Check the components (CHECKING THE SUSPENSION COMPONENTS).

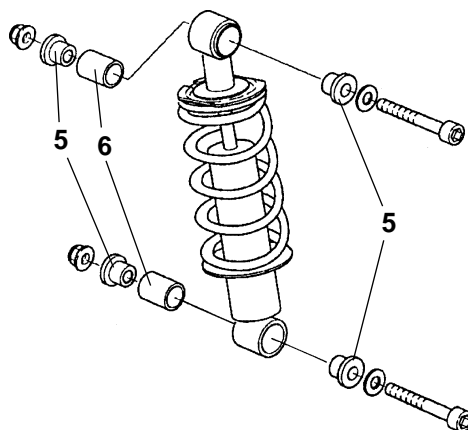

CHECKING THE SUSPENSION COMPONENTS

▲ WARNING

Ensure that none of the components show any signs of bending, cracking, or denting. Replace any damaged components.



GASKETS

Check the condition of the gaskets; replace them if there are any signs of damage or excessive wear.

7

SHOCK ABSORBER

Check that the spring is not distorted and that the movement of the shock absorber is smooth and gradual.

Ensure that no oil is leaking.

Replace the shock absorber if it shows any trace of leakage or if the shaft is in any way damaged.

REMOVING THE DRIVE CHAIN

Read carefully (**SERVICE SCHEDULE**) and (**PRECAUTIONS AND GENERAL INFORMATION**).

Position the motorcycle on the rear stand **OPT** (**POSITIONING THE MOTORCYCLE ON THE REAR STAND**).

Rear stand: 8705021.

▲ WARNING

Take extra care to ensure that your fingers are not caught between the chain and the rear sprocket. Wear heavy work gloves when performing this operation. If your fingers become entangled in the chain and rear sprocket, you will amputate a finger or suffer other serious injury.

Using a small blade screwdriver, or a pair of needle-nose pliers, remove the master link clip (1). Remove the plate (2a) and the master link (2b). Pull the chain (3) rearward of the front sprocket.

▲ WARNING

When refitting the chain (3), make sure that the master link clip (1) is fitted with the open end facing opposite the direction of travel. Failure to adhere to this instruction can lead to the spontaneous loss of the master link and chain. This can cause seizure of the rear wheel, which can lead to loss of control and upset, with subsequent serious injury or even death. Also, if the master link comes out, the chain can flail around and injure you.

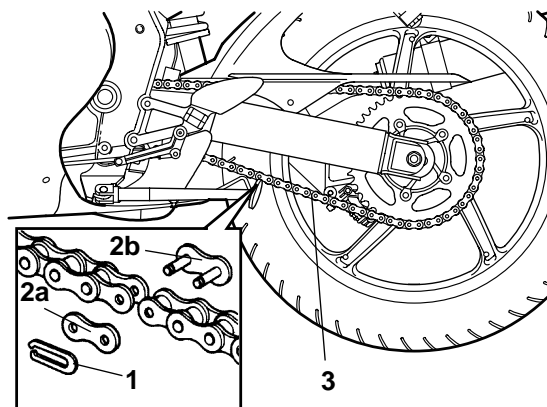

▲ WARNING

An excessively loose chain can come off the sprocket, which can also result in rear wheel jamming, as well as serious damage to the motorcycle. Never ride your motorcycle with an improperly adjusted chain (**CHAIN ADJUSTMENT**).

▲ CAUTION

Lack of maintenance can cause premature wear of the chain and damage to the sprockets. Clean and lubricate your chain more often if your motorcycle is used on dusty or muddy roads.

REMOVING THE SWING ARM

Read carefully (PRECAUTIONS AND GENERAL INFORMATION).

Remove the side fairings (REMOVING THE SIDE FAIRINGS).

Remove the saddle cowl (REMOVING THE LOWER FAIRING).

Remove the exhaust pipe, (REMOVING THE EXHAUST PIPE AND MUFFLER).

▲ CAUTION

Place a stand of suitable height and strength under the engine cradle, so that the motorcycle stays stable during the disassembly and reassembly work.

Proceed with great care when removing the swing arm.

Remove the chain (REMOVING THE DRIVE CHAIN).
Remove the rear wheel (REMOVING THE COMPLETE REAR WHEEL).

Withdraw the caliper mounting plate (1), complete with the rear brake caliper (2), with the tubes still connected up.

▲ CAUTION

Danger of brake fluid spilling out. Do not work the rear brake lever when the fluid reservoir cap is loosened or removed.

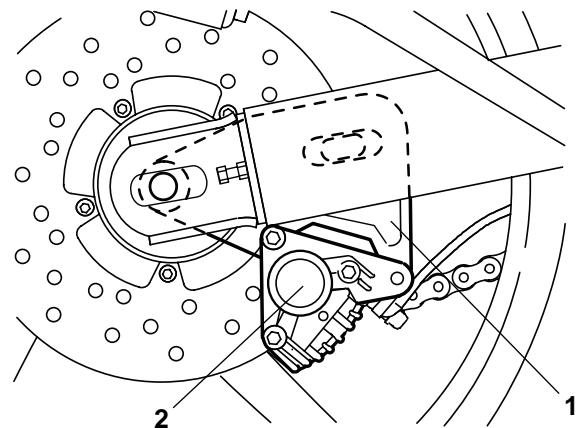

Loosen and remove the nut (3) and push out the screw (4) partially.

**Torque setting for nut (3):
48 Nm (4.8 kgm) [35.4 Ft-lb].**

Remove the screw (4) and take the rear suspension (5) out from the front.

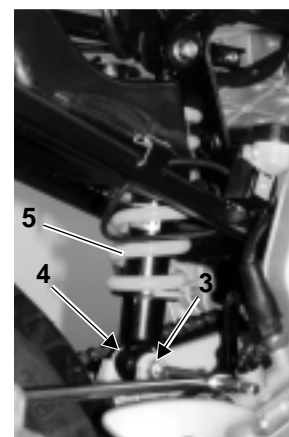

NOTE Use the special tool **OPT** (swing arm pin adjustment socket wrench).

Using the special socket wrench **OPT** (6), loosen and remove the locking ring nut (7).

Swing arm pin adjustment socket wrench: 8101945

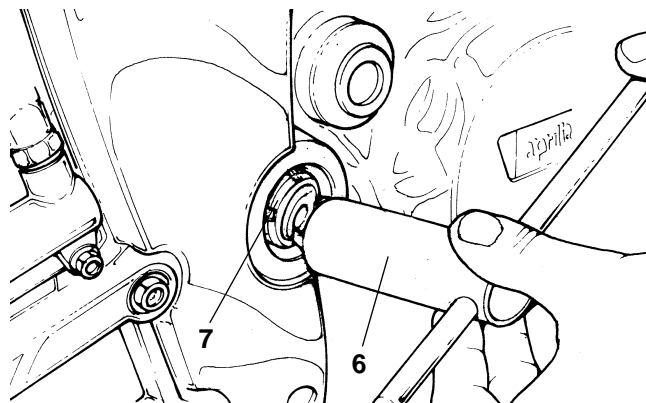

▲ WARNING

Because of the weight of the rear part, the following operations require a second person.

Agree before hand on the procedure.

Proceed with great care when removing the swing arm.

Support the front of the swing arm to stop it falling accidentally.

Remove the rear wheel (see REMOVING THE REAR WHEEL).

Working from the right side of the motorcycle, turn the adjustment bush (8) clockwise until it is fully loosened.

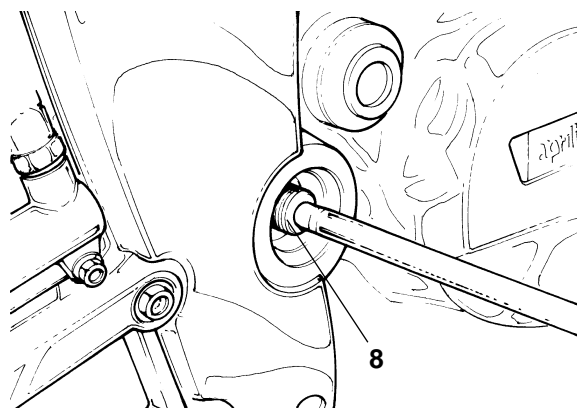

Support the front of the swinging arm while removing the swinging arm pivot bolt (9) from the left. Remove the complete swinging arm from the rear, and remove the two washers from the pivot (9). Using a drift of suitable diameter, tap the bush (8) from the left side of the motorcycle. If necessary, remove the chain guide (REMOVING THE CHAIN GUIDE).

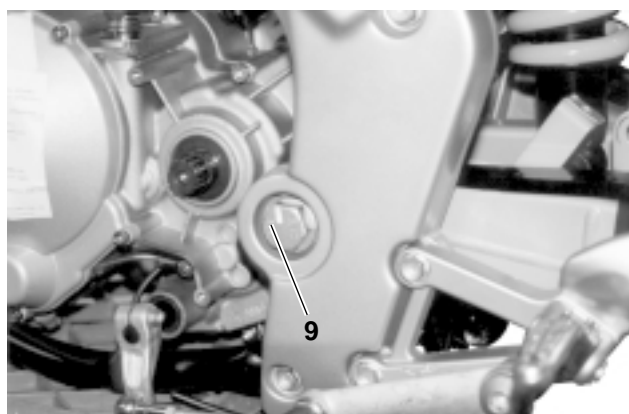

DISASSEMBLING THE SWING ARM

Read carefully (PRECAUTIONS AND GENERAL INFORMATION).

Remove the bushes (1).

Remove the O-rings (2).

▲ WARNING

When reassembling, use 2 new O-rings (2).

Remove the internal spacer (3).

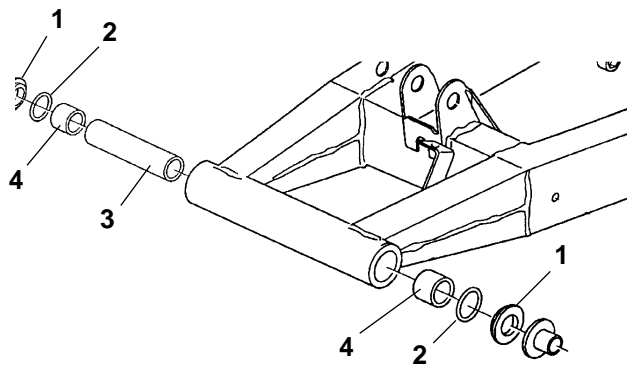

Using a drift of suitable diameter, remove the internal bushes (4).

NOTE Wash all components with clean detergent.

▲ WARNING

When refitting the internal bushes (4), use a jig of suitable diameter.

CHECKING THE COMPONENTS

▲ WARNING

Ensure that none of the components show any signs of bending, cracking, or denting. Replace any damaged components.

GASKETS

Check the condition of the gaskets; replace them if they show any signs of damage or excess wear.

REASSEMBLING THE SWING ARM

Read carefully (PRECAUTIONS AND GENERAL INFORMATION).

Install the internal spacer (3).

Using an appropriate shoulder drift, install the internal bushings (2), fit to the O-ring seals (4) fit the two outer bushings (6) in the left side of the swinging arm, ensuring that it is driven fully home.

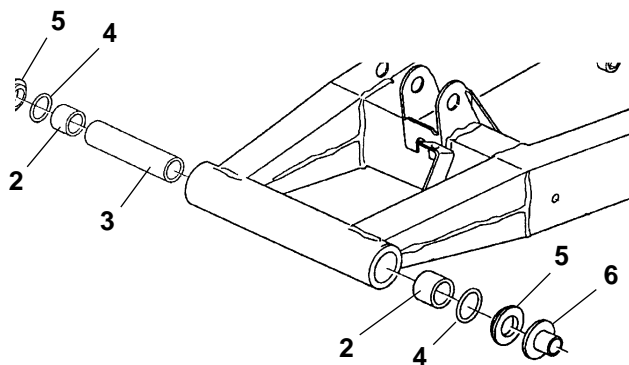

Install the two washers (7) into the swinging arm pivot (1).

Apply a thin film of grease along the whole length of the pivot.

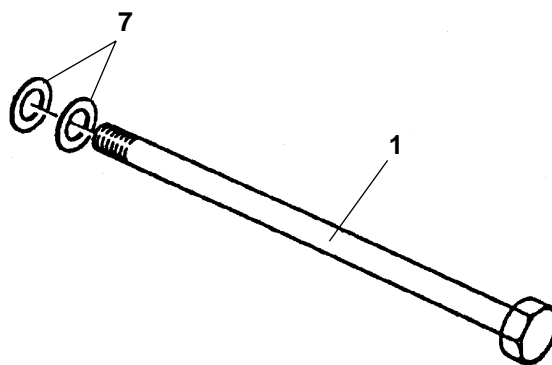

Move the swinging arm into position so that the pivots pass through the holes in the frame and the holes in the swing arm.

Insert the adjustment bush (8), pressing it fully home against the swingarm.

Insert the swingarm pivot (1).

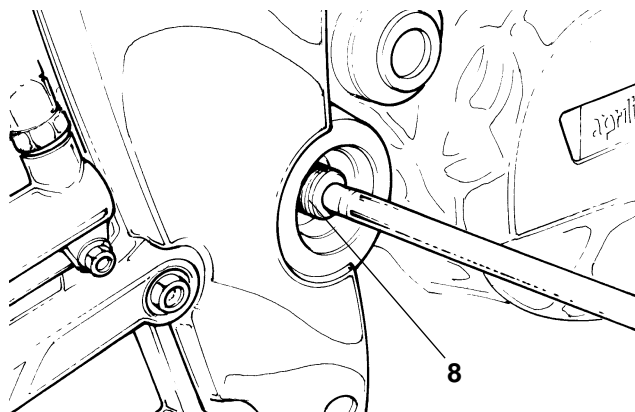

NOTE Use the special tool (9) OPT (swing arm pin adjustment socket wrench).

Swing arm pin adjustment socket wrench: 8101945.

Insert the adjustment ring nut (10) and tighten manually with the tool (9).

NOTE The flat side of the adjustment ring nut (10) must be against the frame.

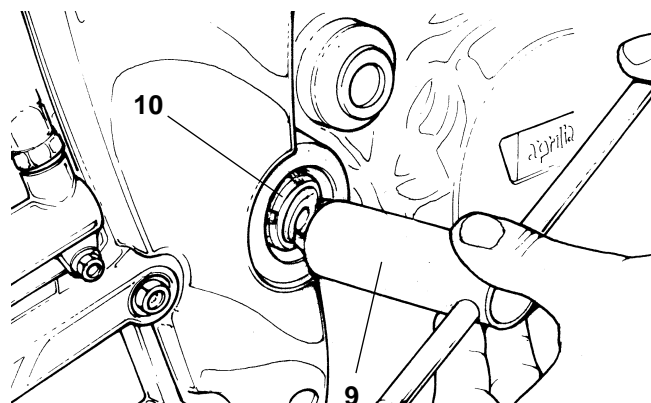

Fully tighten the pin (1).

Torque setting for pin (1):
70 Nm (7 kgm) [5.2 Ft-lb].

NOTE From this point, proceed with the refitting of the swing arm by going through the removal procedure in reverse order, starting from REMOVING THE SWING ARM.

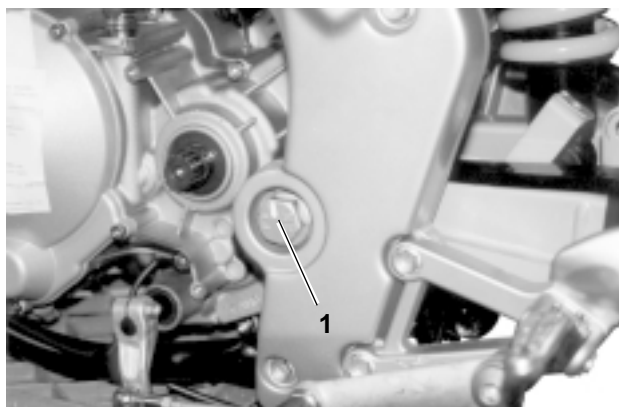

aprilia s.p.a.

Via G. Galilei, 1
30033 Noale (VE)
Tel. +39 (0) 41 - 5829111
Fax +39 (0) 41 - 441054
www.aprilia.com
www.serviceaprilia.com
Italy

8140250



Produced by **Fornacette (PI) - ITALY**