

ORION[®]

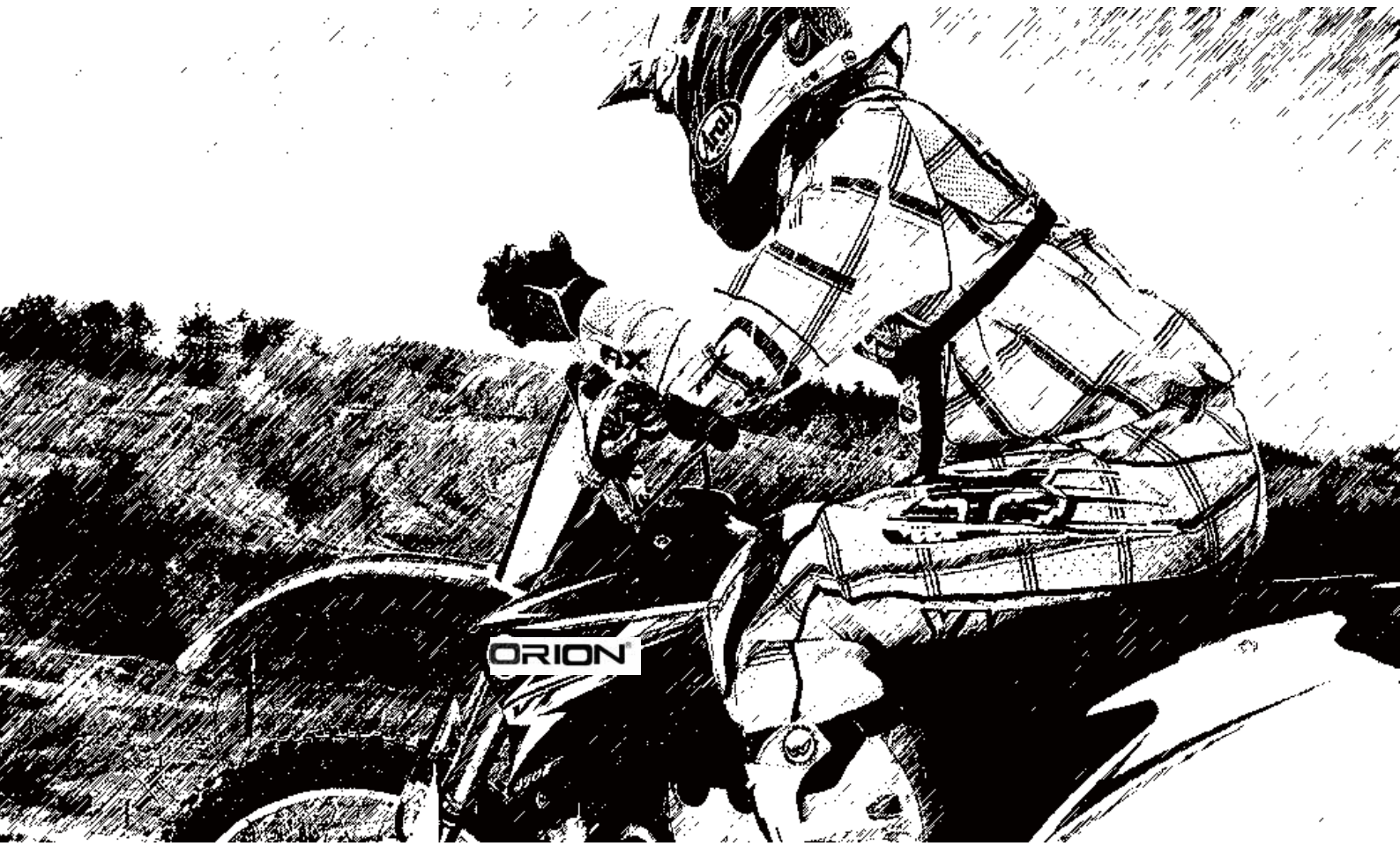

SERVICE MANUAL

AGB-21G

ORION[®]



INTRODUCTION

Congratulations on your purchase of an Apollo AGB-21G.

NOTE:

As improvements are made on this model, some data in this manual may become outdated. If you have any questions, please consult your dealer.

⚠ WARNING

PLEASE READ THIS MANUAL CAREFULLY AND COMPLETELY BEFORE OPERATING THIS MACHINE. DO NOT ATTEMPT TO OPERATE THIS MACHINE UNTIL YOU HAVE ATTAINED A SATISFACTORY KNOWLEDGE OF ITS CONTROLS AND OPERATING FEATURES AND UNTIL YOU HAVE BEEN TRAINED IN SAFE AND PROPER RIDING TECHNIQUES. REGULAR INSPECTIONS AND CAREFUL MAINTENANCE, ALONG WITH GOOD RIDING SKILLS, WILL ENSURE THAT YOU SAFELY ENJOY THE CAPABILITIES AND THE RELIABILITY OF THIS MACHINE.

IMPORTANT NOTICE

II

THIS MACHINE IS DESIGNED STRICTLY FOR COMPETITION USE, ONLY ON A CLOSED COURSE. It is illegal for this machine to be operated on any public street, road, or highway. Off-road use on public lands may also be illegal. Please check local regulations before riding.

⚠ SAFETY INFORMATION

- 1. THIS MACHINE IS TO BE OPERATED BY AN EXPERIENCED RIDER ONLY.**
Do not attempt to operate this machine at maximum power until you are totally familiar with its characteristics.
- 2. THIS MACHINE IS DESIGNED TO BE RIDDEN BY THE OPERATOR ONLY.**
Do not carry passengers on this machine.
- 3. ALWAYS WEAR PROTECTIVE APPAREL.**
When operating this machine, always wear an approved helmet with goggles or a face shield. Also wear heavy boots, gloves, and protective clothing. Always wear proper fitting clothing that will not be caught in any of the moving parts or controls of the machine.
- 4. ALWAYS MAINTAIN YOUR MACHINE IN PROPER WORKING ORDER.**
For safety and reliability, the machine must be properly maintained. Always perform the pre-operation checks indicated in this manual. Correcting a mechanical problem before you ride may prevent an accident.
- 5. GASOLINE IS HIGHLY FLAMMABLE.**
Always turn off the engine while refueling. Take care to not spill any gasoline on the engine or exhaust system. Never refuel in the vicinity of an open flame, or while smoking.

6. GASOLINE CAN CAUSE INJURY.

If you should swallow some gasoline, inhale excess gasoline vapors, or allow any gasoline to get into your eyes, contact a doctor immediately. If any gasoline spills onto your skin or clothing, immediately wash skin areas with soap and water, and change your clothes.

7. ONLY OPERATE THE MACHINE IN AN AREA WITH ADEQUATE VENTILATION.

Never start the engine or let it run for any length of time in an enclosed area. Exhaust fumes are poisonous. These fumes contain carbon monoxide, which by itself is odorless and colorless. Carbon monoxide is a dangerous gas which can cause unconsciousness or can be lethal.

8. PARK THE MACHINE CAREFULLY; TURN OFF THE ENGINE.

Always turn off the engine if you are going to leave the machine. Do not park the machine on a slope or soft ground as it may fall over.

9. THE ENGINE, EXHAUST PIPE, MUFFLER, AND OIL TANK WILL BE VERY HOT AFTER THE ENGINE HAS BEEN RUN.

Be careful not to touch them or to allow any clothing item to contact them during inspection or repair.

10. PROPERLY SECURE THE MACHINE BEFORE TRANSPORTING IT.

When transporting the machine in another vehicle, always be sure it is properly secured and in an upright position and that the fuel cock is in the " OFF " position. Otherwise, fuel may leak out of the carburetor or fuel tank.

TO THE NEW OWNER

This manual will provide you with a good basic understanding of features, operation, and basic maintenance and inspection items of this machine. Please read this manual carefully and completely before operating your new machine. If you have any questions regarding the operation or maintenance of your machine, please consult your dealer.

NOTE:

This manual should be considered a permanent part of this machine and should remain with it even if the machine is subsequently sold.

NOTICE

Some data in this manual may become outdated due to improvements made to this model in the future. If there is any question you have regarding this manual or your machine, please consult your dealer.

F.I.M. MACHINE WEIGHTS:

Weights of machines without fuel

The minimum weights for motocross machines are:

for the class 125cc..... minimum
64 kg

In modifying your machine (e.g., for weight reduction), take note of the above limits of weight.

HOW TO USE THIS MANUAL

PARTICULARLY IMPORTANT INFORMATION



The Safety Alert Symbol means ATTENTION! BECOME ALERT! YOUR SAFETY IS INVOLVED!

⚠ WARNING

Failure to follow WARNING instructions could result in severe injury or death to the machine operator, a bystander, or a person inspecting or repairing the machine.

CAUTION:

A CAUTION indicates special precautions that must be taken to avoid damage to the machine.

NOTE:

A NOTE provides key information to make procedures easier or clearer.

MANUAL FORMAT

All of the procedures in this manual are organized in a sequential, step-by-step format. The information has been compiled to provide the mechanic with an easy to read, handy reference that contains comprehensive explanations of all disassembly, repair, assembly, and inspection operations. In this revised format, the condition of a faulty component will precede an arrow symbol and the course of action required will follow the symbol, e.g.,

- Bearings
Pitting/damage → Replace.

INDEX

GENERAL INFORMATION

1

SPECIFICATIONS

2

REGULAR INSPECTION AND ADJUSTMENTS

3

ENGINE

4

CHASSIS

5

ELECTRICAL

6

GENERAL INFORMATION

DESCRIPTION

- 1 Clutch lever
- 2 Engine stop switch
- 3 Front brake lever
- 4 Throttle grip
- 5 Fuel tank cap
- 6 Engine start switch
- 7 Fuel tank
- 8 Air filter
- 9 Left side cover
- 10 Drive chain
- 11 Shift pedal
- 12 Side stand
- 13 Right side cover
- 14 Fuel cock
- 15 Kick starter cank
- 16 Front fork
- 17 Spark plug
- 18 Rear brake pedal
- 19 Front axle

NOTE:

- The machine you have purchased may differ slightly from those shown in the following.
- Designs and specifications are subject to change without notice.

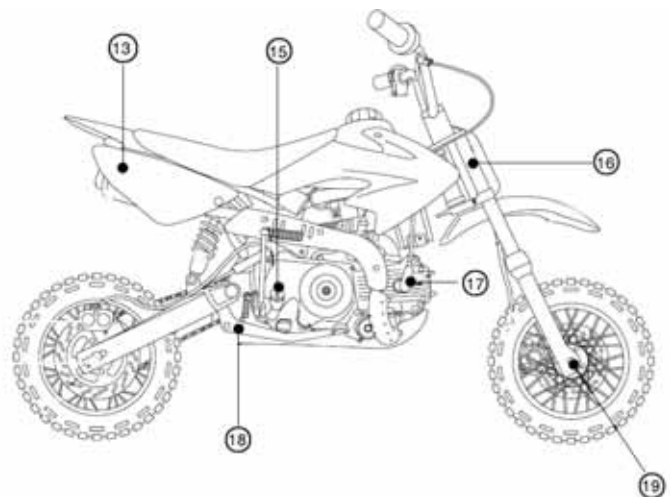
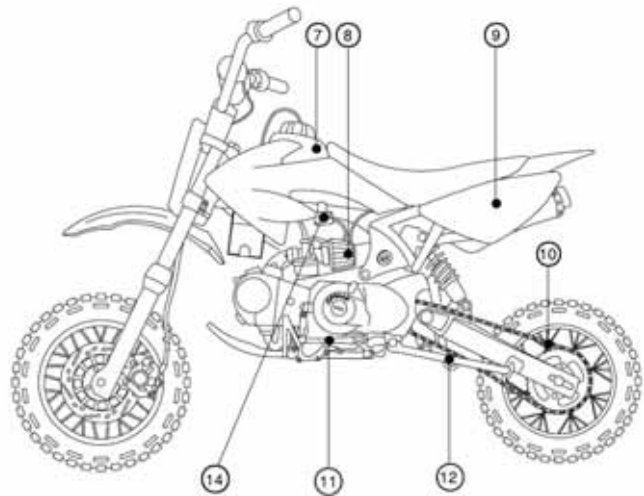
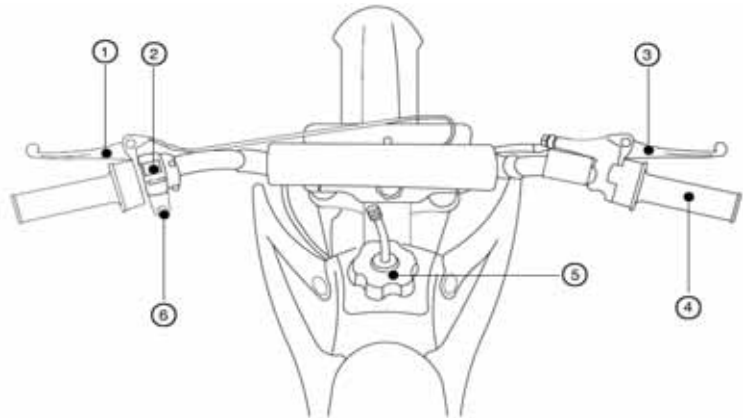

MACHINE IDENTIFICATION

MACHINE IDENTIFICATION

There are two significant reasons for knowing the serial number of your machine:

1. When ordering parts, you can give the number to your dealer for positive identification of the model you own.
2. If your machine is stolen, the authorities will need the number to search for and identify your machine.

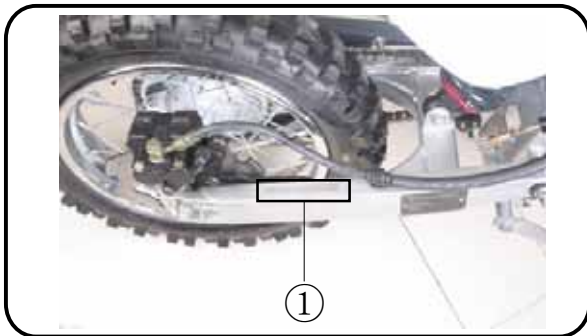

VEHICLE IDENTIFICATION NUMBER

The vehicle identification number is stamped on the right of the steering head pipe.



ENGINE SERIAL NUMBER

The engine serial number is stamped into the elevated part of the right-side of the engine.

IMPORTANT INFORMATION

PREPARATION FOR REMOVAL AND DISASSEMBLY

1. Remove all dirt, mud, dust, and foreign material before removal and disassembly.
When washing the machine with high pressured water, cover the parts follows.
 - Silencer exhaust port
 - Side cover air intake port
2. Use proper tools and cleaning equipment. Refer to "SPECIAL TOOLS" section.
3. When disassembling the machine, keep mated parts together. They include gears, cylinders, pistons, and other mated parts that have been "mated" through normal wear. Mated parts must be reused as an assembly or replaced.
4. During the machine disassembly, clean all parts and place them in trays in the order of disassembly. This will speed up assembly time and help assure that all parts are correctly reinstalled.
5. Keep away from fire.

IMPORTANT INFORMATION

GASKETS, OIL SEALS AND O-RINGS

1. All gaskets, oil seals, and O-rings should be replaced when an engine is overhauled. All gasket surfaces, oil seal lips, and O-rings must be cleaned.
2. Properly oil all mating parts and bearings during reassembly. Apply grease to the oil seal lips.

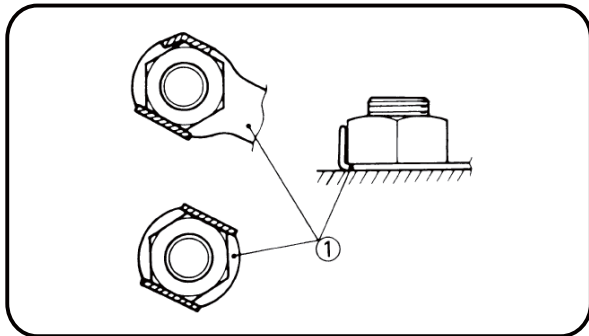

LOCK WASHERS/PLATES AND COTTER PINS

1. All lock washers/plates and cotter pins must be replaced when they are removed. Lock tab(s) should be bent along the bolt or nut flat(s) after the bolt or nut has been properly tightened.

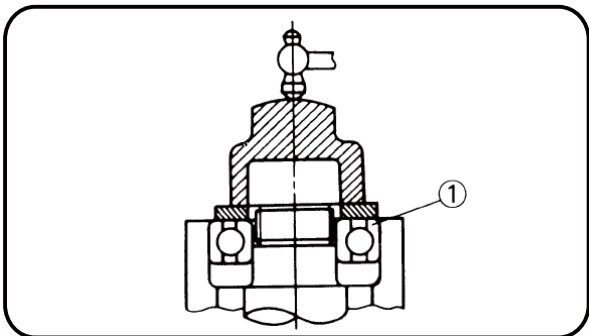

BEARINGS AND OIL SEALS

1. Install the bearing(s) and oil seal(s) with their manufacturer's marks or numbers facing outward. (In other words, the stamped letters must be on the side exposed to view.) When installing oil seal(s), apply a light coating of light-weight lithium base grease to the seal lip(s). Oil the bearings liberally when installing.

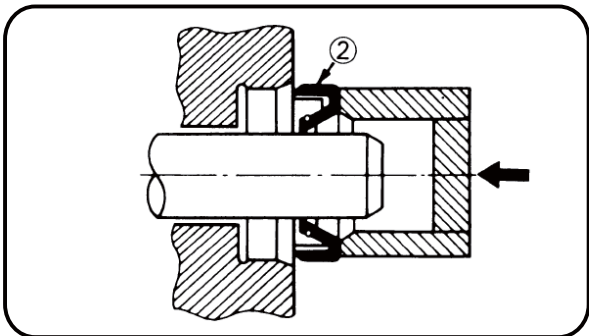

CAUTION:

Do not use compressed air to spin the bearings dry. This causes damage to the bearing surfaces.

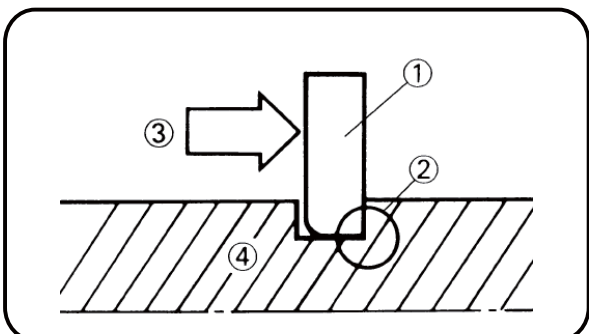

CIRCLIPS

1. All circlips should be inspected carefully before reassembly. Always replace piston pin clips after one use. Replace distorted circlips. When installing a circlip, make sure that the sharp-edged corner is positioned opposite to the thrust it receives. See the sectional view.
Shaft

CHECKING OF CONNECTION

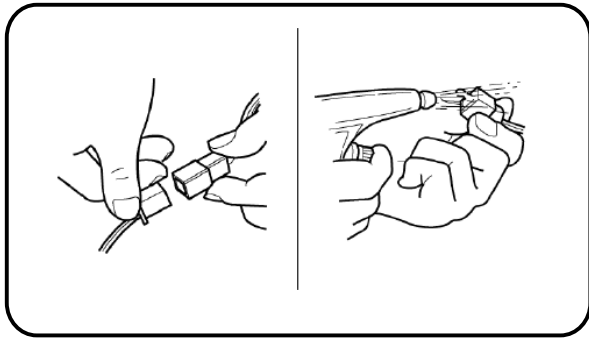

CHECKING OF CONNECTION

Dealing with stains, rust, moisture, etc. on the connector.

1. Disconnect:
 - Connector
2. Dry each terminal with an air blower.

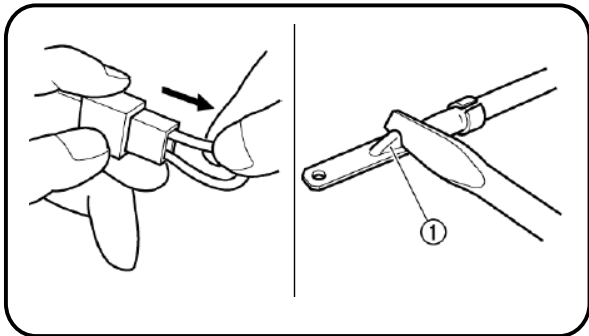

3. Connect and disconnect the connector two or three times.
4. Pull the lead to check that it will not come off.
5. If the terminal comes off, bend up the pin and reinsert the terminal into the connector.

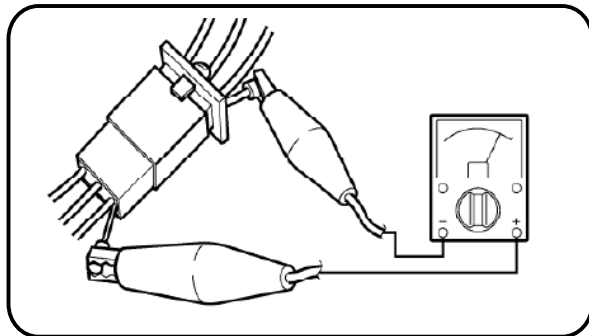

6. Connect:
 - Connector

NOTE: _____
The two connectors “click” together.

7. Check for continuity with a tester.

NOTE: _____

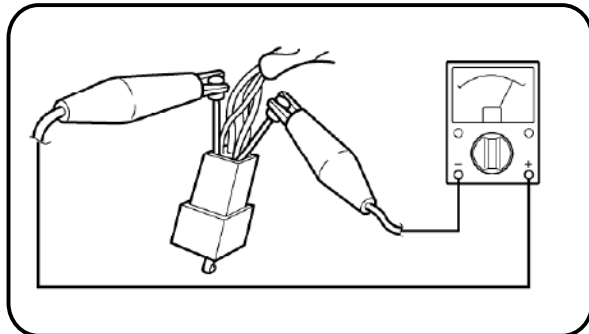

- If there is no continuity, clean the terminals.
- Be sure to perform the steps 1 to 7 listed above when checking the wireharness.
- For a field remedy, use a contact revitalizer available on the market.
- Use the tester on the connector as shown.



SPECIAL TOOLS

SPECIAL TOOLS

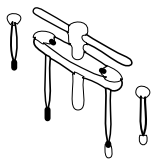
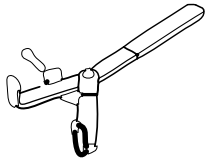
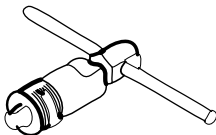
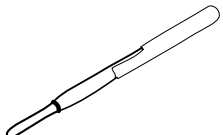
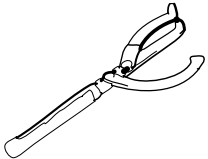
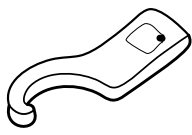
The proper special tools are necessary for complete and accurate tune-up and assembly. Using the correct special tool will help prevent damage caused by the use of improper tools or improvised techniques. The shape and part number used for the special tool differ by country, so two types are provided. Refer to the list provided to avoid errors when placing an order.

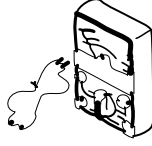
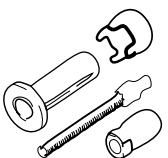
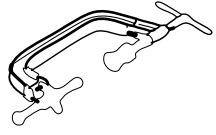
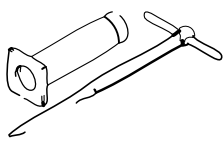
Tool name/How to us	Illustration	Tool name/How to us	Illustration
<p>Crankcase separating tool</p> <p>These tool is used to remove the crankshaft from either case.</p>		<p>Clutch holding tool</p> <p>This tool is used to hold the clutch when removing or installing the clutch boss securing nut.</p>	
<p>Flywheel puller</p> <p>This tool is used to remove the flywheel magneto.</p>		<p>Valve guide remover</p> <p>This tool is needed to remove and install the valve guide.</p>	
<p>Rotor holding tool</p> <p>This tool is used when loosening or tightening the fly-wheel magneto securing nut</p>		<p>Steering nut wrench</p> <p>This tool is used when tighten the steering ring nut to specification.</p>	
<p>Dial gauge and stand Stand</p> <p>These tools are used to check each part for runout or bent.</p>		<p>Pocket tester</p> <p>Use this tool to inspect the coil resistance, output voltage and amperage.</p>	
<p>Crankshaft installing tool/pot/bolt Spacer (crankshaft installer) Adapter (M12)</p> <p>These tools are used to install the crankshaft.</p>		<p>Valve spring compressor</p> <p>This tool is needed to remove and install the valve assemblies.</p>	
<p>Piston pin puller set</p> <p>This tool is used to remove the piston pin.</p>			

CONTROL FUNCTIONS

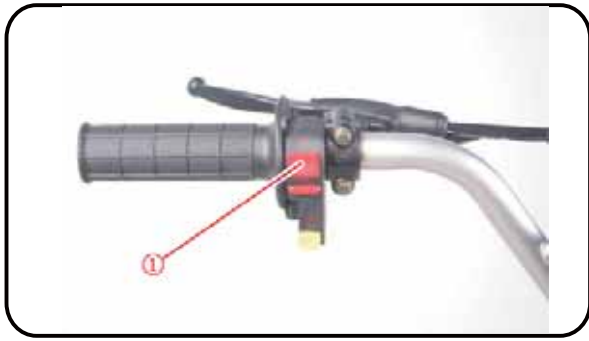

CONTROL FUNCTIONS

ENGINE STOP SWITCH

The engine stop switch is located on the left handlebar. Continue pushing the engine stop switch till the engine comes to a stop.

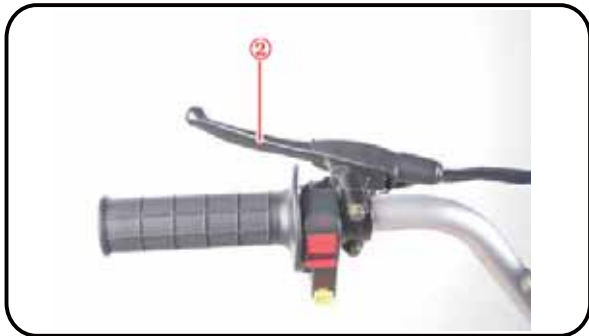

CLUTCH LEVER

The clutch lever is located on the left handlebar; it disengages or engages the clutch. Pull the clutch lever to the handlebar to disengage the clutch, and release the lever to engage the clutch. The lever should be pulled rapidly and released slowly for smooth starts.



SHIFT PEDAL

The gear ratios of the constant-mesh 4 speed transmission are ideally spaced. The gears can be shifted by using the shift pedal on the left side of the engine.



KICKSTARTER CRANK

Rotate the kickstarter crank away from the engine. Push the starter down lightly with your foot until the gears engage, then kick smoothly and forcefully to start the engine. This model has a primary kickstarter crank so the engine can be started in any gear if the clutch is disengaged. In normal practices, however, shift to neutral before starting.

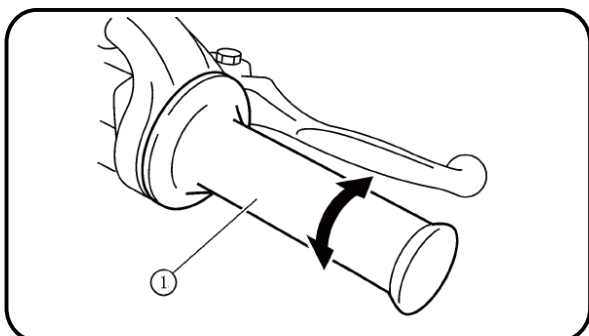

THROTTLE GRIP

The throttle grip is located on the right handlebar; it accelerates or decelerates the engine. For acceleration, turn the grip toward you; for deceleration, turn it away from you.

CONTROL FUNCTIONS

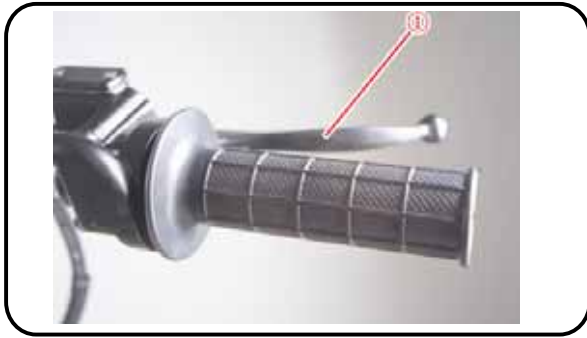

FRONT BRAKE LEVER

The front brake lever is located on the right handlebar. Pull it toward the handlebar to activate the front brake.



REAR BRAKE PEDAL

The rear brake pedal is located on the right side of the machine. Press down on the brake pedal to activate the rear brake.



FUEL COCK

The fuel cock supplies fuel from the tank to carburetor while filtering the fuel. The fuel cock has the two positions:

OFF: With the lever in this position, fuel will not flow. Always return the lever to this position when the engine is not running.

ON: With the lever in this position, fuel flows to the carburetor. Normal riding is done with the lever in this position



SPARK PLUG WRENCH

This spark plug wrench is used to remove and install the spark plug.



NIPPLE WRENCH

This nipple wrench is used to tighten the spoke.

GENERAL SPECIFICATIONS

SPECIFICATIONS

Model name:	21G
Model code number:	AGB-21G
Dimensions:	
Overall length	1,550 mm
Overall width	600 mm
Overall height	830 mm
Seat height	690 mm
Wheelbase	1,105 mm
Minimum ground clearance	260 mm
Basic weight:	
With oil and full fuel tank	66kg
Engine:	
Engine type	Air cooled 4-stroke
Cylinder arrangement	Single cylinder, forward inclined
Displacement	123.67 cm ³
Bore × stroke	54.0 × 54 mm
Compression ratio	9 : 1
Starting system	Kickstarter and Electrical Starting
Lubrication system:	Dry sump
Oil type or grade:	
	At 5 °C (40 °F) or higher SF15W/40 type SG motor oil (Non-Friction modified) At 15 °C (60 °F) or lower

GENERAL SPECIFICATIONS

Oil capacity: Engine oil Periodic oil change With oil filter replacement Total amount	0.8 L 0.85 L 0.9 L
Air filter:	Wet type element
Fuel: Type Tank capacity	Premium unleaded gasoline only with a research octane number of 90 or higher. Premium gasoline 3.5 L
Carburetor: Type Manufacturer	PZ26-5K JINGKE
Spark plug: Type/manufacturer Gap	A7RTC/NGK 0.6 ~ 0.7 mm
Clutch type:	Wet, multiple-disc
Transmission: Primary reduction system Primary reduction ratio Secondary reduction system Secondary reduction ratio Transmission type Operation Gear ratio: 1st 2nd 3rd 4th	Gear 67/18 (3.772) Chain drive 43/15 (2.867) Constant mesh, 4-speed Left foot operation 36/11 (2.818) 31/16 (1.938) 27/20 (1.350) 24/23 (1.043)
Chassis: Frame type Caster angle	Semi double cradle 27.3°
Tire: Type Size (front) Size (rear) Tire pressure (front and rear)	With tube 60/100-14 30M 80/100-12 41M 130 kPa (1.3 kgf/cm ²)

GENERAL SPECIFICATIONS

Brake: Front brake type Operation Rear brake type Operation	Single disc brake Right hand operation Single disc brake Right foot operation
Suspension: Front suspension Rear suspension	Telescopic fork Swingarm (link type monocross suspension)
Shock absorber: Front shock absorber Rear shock absorber	Coil spring/oil damper Coil spring/oil damper
Wheel travel: Front wheel travel Rear wheel travel	200 mm 200 mm
Electrical: Ignition system	CDI magneto

MAINTENANCE SPECIFICATIONS

ENGINE

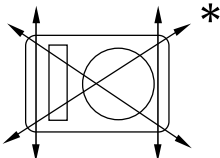
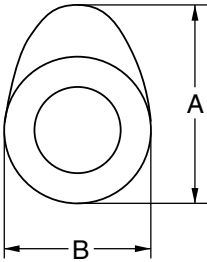
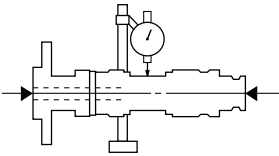
Item	Standard	Limit	
Cylinder head: Warp limit 	----	0.03 mm	
Cylinder: Bore size Out of round limit	54.00 ~ 54.015 mm ----	---- 0.05 mm	
Camshaft: Drive method Camshaft cap inside diameter Camshaft outside diameter Shaft-to-cap clearance Cam dimensions 	Chain drive (Left) 32.009 ~ 32.034 mm 31.963 ~ 31.979 mm 0.030 ~ 0.071 mm ---	---- ---- ---- ---	
Intake Exhaust	“A” “B” “A” “B”	26.555 ~ 26.675 mm 20.99 ~ 21.01 mm 26.316 ~ 26.436 mm 20.99 ~ 21.01 mm ---	26.30 mm 20.95 mm 26.00 mm 20.95 mm 0.03 mm
Camshaft runout limit 	----	0.03 mm	

MAINTENANCE SPECIFICATIONS

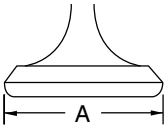
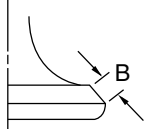
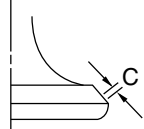
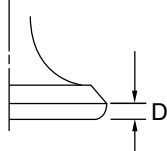
Item	Standard	Limit	
Timing chain:			
Timing chain type / No. of links	90T/90	----	
Timing chain adjustment method	Automatic	----	
Valve, valve seat, valve guide:			
Valve clearance (cold)	IN	0.02 ~ 0.04 mm	
	EX	0.02 ~ 0.04 mm	
Valve dimensions:			
			
Head Diameter	Face Width	Seat Width	Margin Thickness
"A" head diameter	IN	26.9 ~ 27.1 mm	----
	EX	22.9 ~ 23.1 mm	----
"B" face width	IN	1.1~1.5 mm	----
	EX	1.1~1.5 mm	----
"C" seat width	IN	0.9 ~ 1.1 mm	1.6 mm
	EX	0.8 ~ 1.0 mm	1.6 mm
"D" margin thickness	IN	0.65~0.95 mm	----
	EX	0.65~0.95 mm	----
Stem outside diameter	IN	4.97~4.985 mm	4.94 mm
	EX	4.955 ~ 4.97 mm	4.925 mm
Guide inside diameter	IN	5.000 ~ 5.012 mm	5.050 mm
	EX	5.500 ~ 5.512 mm	5.550 mm
Stem-to-guide clearance	IN	0.015 ~ 0.042 mm	0.08 mm
	EX	0.030 ~ 0.057 mm	0.10 mm

MAINTENANCE SPECIFICATIONS

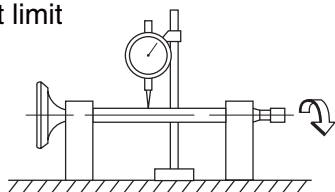
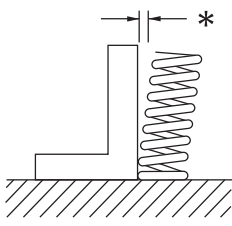
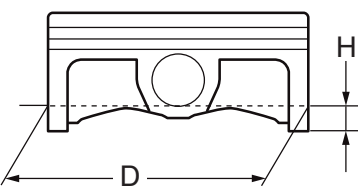
Item			Standard	Limit
Stem runout limit			----	0.03 mm
				
Valve seat width	IN		0.8 ~ 1.2 mm	1.6 mm
	EX		0.8 ~ 1.2 mm	1.6 mm
Valve spring:				
Free length	IN		33.78 mm	32.5 mm
	EX		35.55 mm	34.0 mm
Set length (valve closed)	IN		22.45 mm	----
	EX		25.45 mm	----
Compressed force (installed)	IN		52 ~ 64 N at 22.45 mm	----
	EX		105 ~ 129 N at 25.45 mm	----
Tilt limit*	IN		----	1.3°/0.8 mm
	EX		----	1.35°/0.8mm
				
Direction of winding (top view)	IN		Clockwise	----
	EX		Clockwise	----
Piston:				
Piston to cylinder clearance			0.025 ~ 0.05 mm	0.1 mm
Piston size "D"			53.965 ~ 53.975 mm	----
				
Measuring point "H"			10 mm	----
Piston off-set			0.4 mm /IN-side	----

MAINTENANCE SPECIFICATIONS

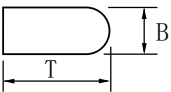
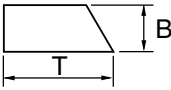
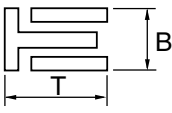
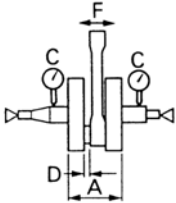
Item	Standard	Limit
Piston pin bore inside diameter	14.002 ~ 14.013 mm	14.04 mm
Piston pin outside diameter	13.994 ~ 14.000 mm	13.98 mm
Piston rings: Top ring: <div style="text-align: center; margin: 10px 0;">  </div> Type Dimensions (B × T) End gap (installed) Side clearance (installed)	Barrel 0.98 × 2.00mm 0.10 ~ 0.25 mm 0.040 ~ 0.080 mm	---- ---- 0.60 mm 0.12 mm
2nd ring: <div style="text-align: center; margin: 10px 0;">  </div> Type Dimensions (B × T) End gap (installed) Side clearance	Taper 0.98 × 2.20 mm 0.15 ~ 0.30 mm 0.040 ~ 0.080 mm	---- ---- 0.60 mm 0.12 mm
Oil ring: <div style="text-align: center; margin: 10px 0;">  </div> Dimensions (B × T) End gap (installed)	1.92 × 2.45 mm 0.20 ~ 0.50 mm	---- ----
Crankshaft: <div style="text-align: center; margin: 10px 0;">  </div> Crank width "A" Runout limit "C" Big end side clearance "D" Small end free play "F"	40.15~ 40.20 mm 0.03 mm 0.15 ~ 0.35mm 0.4 ~ 1.0 mm	---- 0.05 mm 0.60 mm 2.0 mm

MAINTENANCE SPECIFICATIONS

Item	Standard	Limit
Clutch:		
Friction plate thickness	2.85~2.95 mm	2.7 mm
Quantity	3	----
Clutch plate thickness	1.4 ~ 1.6 mm	----
Quantity	3	----
Warp limit	----	0.1 mm
Clutch spring free length	20.5 mm	19.5 mm
Quantity	4	----

Clutch release method	Inner push, cam push	----
Shifter:		
Shifter type	Cam drum and guide bar	----
Guide bar bending limit	----	0.05 mm
Kickstarter:		
Type	Kick and ratchet type	----
Carburetor:		
Type/manufacturer	PZ26-5K / JINGKE	
I. D. mark	JK	----
Main jet (M.J)	85#	----
Main air jet (M.A.J)	ø1.0	----
Jet needle (J.N)	26-5	----
Idle jet (I.J)	38#	----
Float needle valve size (F.N.A)	ø2.0	----
Float weight (F.W)	8 g	----
Float height (F.H)	2.0 ~ 3.0 mm	----
Air throttle (A.T)	B6L	----

MAINTENANCE INTERVALS

REGULAR INSPECTION AND ADJUSTMENTS

MAINTENANCE INTERVALS

The following schedule is intended as a general guide to maintenance and lubrication. Bear in mind that such factors as weather, terrain, geographical location, and individual usage will alter the required maintenance and lubrication intervals. If you are in doubt as to what intervals to follow in maintaining and lubricating your machine, consult your dealer.

Item	After break-in	Every race	Every third (or 500 km)	Every fifth (or 1,000 km)	As required	Remarks
ENGINE OIL Replace Inspect	●	●		●	●	
OIL FILTER ELEMENT, OIL STRAINER Clean				●		
VALVES Check the valve clearances Inspect Replace	●		●	●	●	The engine must be cold. Check the valve seats and valve stems for wear.
VALVE SPRINGS Inspect Replace				●	●	Check the free length and the tilt.
VALVE LIFTERS Inspect Replace				●	●	Check for scratches and wear.
CAMSHAFTS Inspect Replace				●	●	Inspect the camshaft surface. Inspect the decompression system.
TIMING CHAIN SPROCKETS, TIMING CHAIN Inspect Replace				●	●	Check for wear on the teeth and for damage.
PISTON Inspect Clean Replace				●	● ● ●	Inspect crack Inspect carbon deposits and eliminate them.
PISTON RING Inspect Replace				● ●	●	Check ring end gap
PISTON PIN Inspect Replace				●	●	
CYLINDER HEAD Inspect and clean				●		Inspect carbon deposits and eliminate them. Change gasket
CYLINDER Inspect and clean Replace				●	●	Inspect score marks Inspect wear
CLUTCH Inspect and adjust Replace	●	●			●	Inspect housing, friction plate, clutch plate and spring
TRANSMISSION Inspect Replace bearing					● ●	

MAINTENANCE INTERVALS

Item	After break-in	Every race	Every third (or 500 km)	Every fifth (or 1,000 km)	As re- quired	Remarks
SHIFT FORK, SHIFT CAM, GUIDE BAR Inspect					●	Inspect wear
ROTOR NUT Retighten	●			●		
EXHAUST PIPE, SILENCER, PRO- TECTOR Inspect and retighten Clean Replace	●	●		●	●	* Whichever comes first
CRANK Inspect and clean				●	●	
CARBURETOR Inspect, adjust and clean	●	●				When using a high-pres- sure washer, make sure that water does not enter the accelerator pump.
SPARK PLUG Inspect and clean Replace	●		●		●	
DRIVE CHAIN Lubricate, slack, alignment Replace	●	●			●	Use chain lube Chain slack: 30 ~ 40 mm
OUTSIDE NUTS AND BOLTS Retighten	●	●				Refer to "STARTING AND BREAK-IN" section in the CHAPTER 1.
AIR FILTER Clean and lubricate Replace	●	●			●	Use foam air-filter oil or equivalent oil
OIL FILTER Replace	●			●		
OIL STRAINER (frame) Clean				●		
FRAME Clean and inspect	●	●				
FUEL TANK, COCK Clean and inspect	●		●			
BRAKES Adjust lever position and pedal height Lubricate pivot point Check brake disc surface Check fluid level and leakage Retighten brake disc bolts, caliper bolts, master cylinder bolts and union bolts Replace pads Replace brake fluid	● ● ● ● ●	● ● ● ● ●			● ●	Every one year

MAINTENANCE INTERVALS

Item	After break-in	Every race	Every third (or 500 km)	Every fifth (or 1,000 km)	As re- quired	Remarks
FRONT FORKS Inspect and adjust Replace oil Replace oil seal	● ●	●			● ●	
FRONT FORK OIL SEAL AND DUST SEAL Clean and lube	●	●				Lithium base grease
REAR SHOCK ABSORBER Inspect and adjust Lube Retighten	● ●	● ●	●		● (After rain ride)	Molybdenum disulfide grease
DRIVE CHAIN GUIDE AND ROLLERS Inspect	●	●				
SWINGARM Inspect, lube and retighten	●	●				Molybdenum disulfide grease
RELAY ARM, CONNECTING ROD Inspect, lube and retighten	●	●				Molybdenum disulfide grease
STEERING HEAD Inspect free play and retighten Clean and lube Replace bearing	●	●		●	●	Lithium base grease
TIRE, WHEELS Inspect air pressure, wheel run-out, tire wear and spoke looseness Retighten sprocket bolt Inspect bearings Replace bearings Lubricate	● ●	● ●	● ●		●	Lithium base grease
THROTTLE, CONTROL CABLE Check routing and connection Lubricate Inspect and clean (throttle cable)	● ● ●	● ● ●				SAE 10W-30 motor oil Inspect dirt and wear on the throttle cable on the carburetor side.

PRE-OPERATION INSPECTION AND MAINTENANCE

PRE-OPERATION INSPECTION AND MAINTENANCE

Before riding for break-in operation, practice or a race, make sure the machine is in good operating condition.

Before using this machine, check the following points.

GENERAL INSPECTION AND MAINTENANCE

Item	Routine	
Fuel	Check that a fresh gasoline is filled in the fuel tank. Check the fuel line for leakage.	
Engine oil	Check that the oil level is correct. Check the crankcase and frame oil line for leakage.	
Gear shifter and clutch	Check that gears can be shifted correctly in order and that the clutch operates smoothly.	
Throttle grip/Housing	Check that the throttle grip operation and free play are correctly adjusted. Lubricate the throttle grip and housing, if necessary.	
Brakes	Check the play of front brake and effect of front and rear brake.	
Drive chain	Check drive chain slack and alignment. Check that the drive chain is lubricated properly.	
Wheels	Check for excessive wear and tire pressure. Check for loose spokes and have no excessive play.	
Steering	Check that the handlebar can be turned smoothly and have no excessive play.	
Front forks and rear shock absorber	Check that they operate smoothly and there is no oil leakage.	
Cables (wires)	Check that the clutch and throttle cables move smoothly. Check that they are not caught when the handlebars are turned or when the front forks travel up and down.	
Exhaust pipe	Check that the exhaust pipe is tightly mounted and has no cracks.	
Rear wheel sprocket	Check that the rear wheel sprocket tightening bolt is not loose.	
Lubrication	Check for smooth operation. Lubricate if necessary.	
Bolts and nuts	Check the chassis and engine for loose bolts and nuts.	
Lead connectors	Check that the CDI magneto, CDI unit, and ignition coil are connected tightly.	

CLUTCH ADJUSTMENT



CLUTCH ADJUSTMENT

1. Check:
 - Clutch lever free play Δ
Out of specification → Adjust.



Clutch lever free play Δ :
5 ~ 10 mm



2. Adjust:
 - Clutch lever free play

Clutch lever free play adjustment steps:

- Loosen the locknuts
- Adjust the free play by changing their tightening position.
- Tighten the locknuts.



NOTE:

- Make minute adjustment on the lever side using the adjuster
- After adjustment, check proper operation of clutch lever.

THROTTLE CABLE ADJUSTMENT

1. Check:
 - Throttle grip free play \textcircled{a}
Out of specification → Adjust.



Throttle grip free play \textcircled{a} :
3 ~ 5 mm

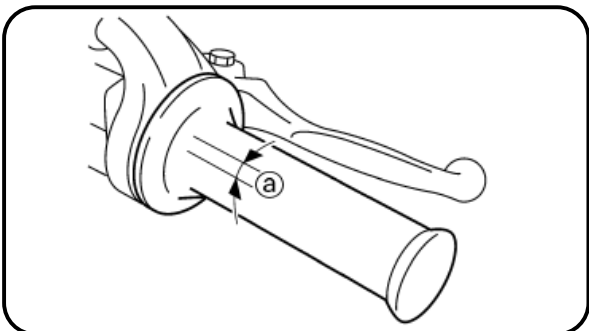

2. Adjust:
 - Throttle grip free play

Throttle grip free play adjustment steps:

- Slide the adjuster cover.
- Turn the adjuster until the specified free play is obtained.
- Tighten the locknut.

NOTE:

Before adjusting the throttle cable free play, the engine idle speed should be adjusted.

⚠ WARNING

After adjusting, turn the handlebar to right and left and make sure that the engine idling does not run faster.



THROTTLE CABLE ADJUSTMENT/ THROTTLE LUBRICATION



THROTTLE LUBRICATION

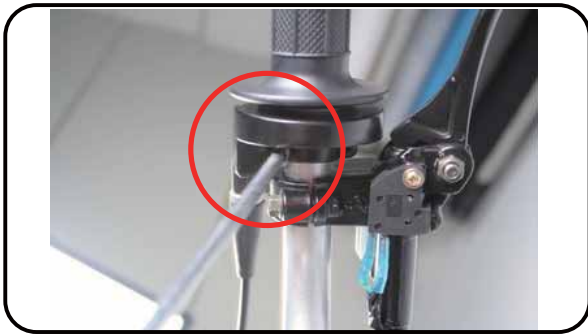

1. Remove:
 - Screw (throttle grip cap)



2. Apply:
 - Lithium soap base grease
On the throttle cable end



3. Install:
 - Screw (throttle grip cap)

 4 Nm (0.4 m · kg)

AIR FILTER REPLACE

NOTE: _____
Proper air filter maintenance is the biggest key to preventing premature engine wear and damage.

CAUTION: _____
Never run the engine without the air filter element in place; this would allow dirt and dust to enter the engine and cause rapid wear and possible engine damage.



1. Remove:
 - Screw

ENGINE OIL LEVEL INSPECTION



2. Install:



- Fitting Screw

 5 Nm (0.5 m · kg)



ENGINE OIL LEVEL INSPECTION

1. Start the engine, warm it up for several minutes, and then turn off the engine and wait for five minutes.
2. Place the machine on a level place and hold it up on upright position by placing the suitable stand under the engine.



3. Remove:
 - Oil tank cap

ENGINE OIL LEVEL INSPECTION

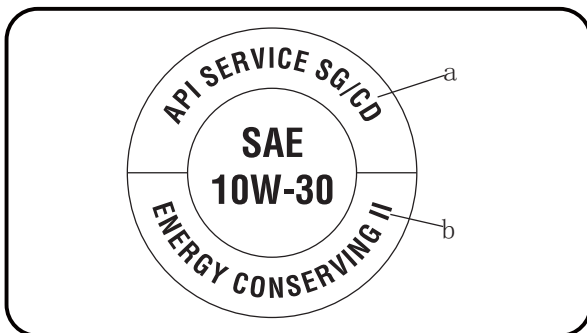
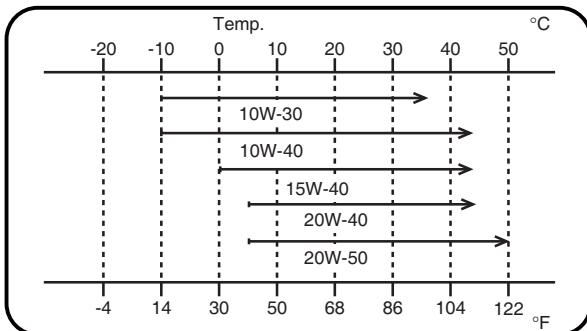

4. Inspect:

- Oil level
Oil level should be between maximum 1 and minimum 2 marks.
Oil level is low → Add oil to proper level.

NOTE:

When inspecting the oil level, do not screw the oil tank cap into the oil tank. Insert the gauge lightly.



Recommended oil:

Refer to the following chart for selection of oils which are suited to the atmospheric temperatures. Recommended engine oil classification:

API STANDARD:

API "SG" or higher grade
(Designed primarily for motorcycles)

CAUTION:

- Do not add any chemical additives or use oils with a grade of CD ^a or higher.
- Do not use oils labeled "ENERGY CONSERVING II" ^b or higher. Engine oil also lubricates the clutch and additives could cause clutch slippage.
- Do not allow foreign materials to enter the crankcase.



5. Install:

- Oil tank cap

6. Start the engine and let it warm up for several minutes.

7. Turn off the engine and inspect the oil level once again.

NOTE:

Wait a few minutes until the oil settles before inspecting the oil level.

ENGINE OIL REPLACEMENT

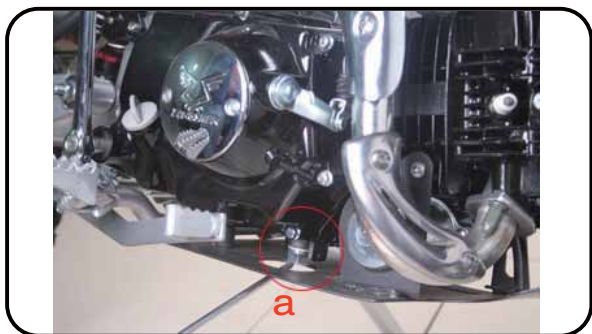

ENGINE OIL REPLACEMENT

1. Start the engine and warm it up for several minutes, and then turn off the engine and wait for five minutes.
2. Place the machine on a level place and hold it on upright position by placing the suitable stand under the engine.
3. Place a suitable container under the engine.
4. Remove:
 - Oil cap
5. Fill:
 - Engine oil



Oil quantity:

Total amount:

0.9 L

Periodic oil change:

0.8 L

With oil filter replacement:

0.85 L

6. Check:
 - Oil leakage
7. Check:
 - Engine oil level

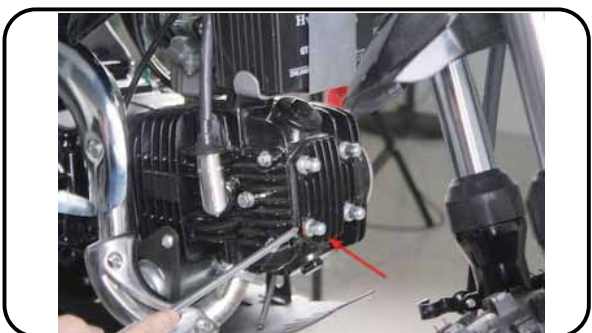

OIL PRESSURE INSPECTION

1. Check:
 - Oil pressure

Checking steps:

- Slightly loosen the oil pressure check bolt
- Start the engine and keep it idling until oil starts to seep from the oil pressure check bolt. If no oil comes out after one minute, turn the engine off so it will not seize.
- Check oil passages and oil pump for damage or leakage.
- Start the engine after solving the problem(s) and recheck the oil pressure.
- Tighten the oil pressure check bolt.



Oil pressure check bolt:

10 Nm (1.0 m • kg)

PILOT SCREW ADJUSTMENT ENGINE IDLING SPEED ADJUSTMENT

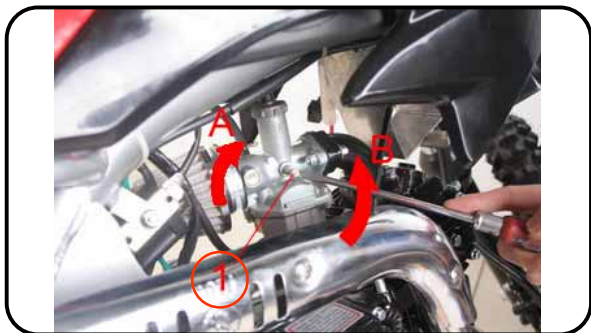

PILOT SCREW ADJUSTMENT

1. Adjust:
 - Pilot screw

Adjustment steps:

NOTE:

To optimize the fuel flow at a smaller throttle opening, each machine's pilot screw has been individually set at the factory. Before adjusting the pilot screw, turn it in fully and count the number of turns. Record this number as the factory-set number of turns out.

- Turn in the pilot screw until it is lightly seated.
- Turn out the pilot screw by the factory-set number of turns.



Pilot screw:
1-5/8 turns out (example)

ENGINE IDLING SPEED ADJUSTMENT

1. Start the engine and thoroughly warm it up.
2. Attach:
 - Inductive tachometer
To spark plug lead.
3. Adjust:
 - Engine idling speed

Adjustment steps:

- Adjust the pilot screw.
Refer to "PILOT SCREW ADJUSTMENT" section.
- Turn the throttle stop screw until the engine runs at the lowest possible speed.

To increase idle speed → Turn the throttle stop screw in A.

To decrease idle speed → Turn the throttle stop screw out B.



Engine idling speed:
1,400 ~ 1,600 r/min

CHASSIS/BRAKE SYSTEM AIR BLEEDING



CHASSIS

BRAKE SYSTEM AIR BLEEDING

⚠ WARNING

Bleed the brake system if:

- The system has been disassembled.
- A brake hose has been loosened or removed.
- The brake fluid is very low.
- The brake operation is faulty.

A dangerous loss of braking performance may occur if the brake system is not properly bled.

1. Remove:
 - Reservoir cap
 - Diaphragm
2. Bleed:
 - Brake fluid

A Front

B Rear

Air bleeding steps:

- a. Add proper brake fluid to the reservoir.
- b. Install the diaphragm. Be careful not to spill any fluid or allow the reservoir to overflow.
- c. Connect the clear plastic tube tightly to the caliper bleed screw.
- d. Place the other end of the tube into a container.
- e. Slowly apply the brake lever or pedal several times.
- f. Pull the lever in or push down on the pedal. Hold the lever or pedal in position.
- g. Loosen the bleed screw and allow the lever or pedal to travel towards its limit.
- h. Tighten the bleed screw when the lever or pedal limit has been reached; then release the lever or pedal.



Bleed screw:
6 Nm (0.6 m • kg)

- i. Repeat steps (e) to (h) until the air bubbles have been removed from the system.

FRONT BRAKE ADJUSTMENT REAR BRAKE ADJUSTMENT

NOTE:

If bleeding is difficult, it may be necessary to let the brake fluid system stabilize for a few hours. Repeat the bleeding procedure when the tiny bubbles in the system have disappeared.

- j. Add brake fluid to the level line on the reservoir.

▲ WARNING

Check the operation of the brake after bleeding the brake system.

- 3. Install:
 - Diaphragm
 - Reservoir cap

FRONT BRAKE

- 1. Check:
 - Brake lever position A



	Brake lever position A :	
Standard position	Extent of adjustment	
100 mm	Unavailable	

REAR BRAKE ADJUSTMENT

- 1. Check:
 - Brake pedal height A
 Out of specification → Adjust.



	Brake pedal height A :	
	10 mm	

- 2. Adjust:
 - Brake pedal height

Pedal height adjustment steps:

- Loosen the locknut
- Turn the adjusting nut until the pedal height a is within specified height.
- Tighten the locknut.

▲ WARNING

- Adjust the pedal height between the maximum and the minimum
- After the pedal height adjustment, make sure that the rear brake does not drag.



FRONT BRAKE PAD INSPECTION AND REPLACEMENT



FRONT BRAKE PAD INSPECTION AND REPLACEMENT

1. Inspect:
 - Brake pad thickness A
Out of specification → Replace as a set.



Brake pad thickness:
4.0 mm
<Limit>: 1.0 mm



2. Replace:
 - Brake pad

Brake pad replacement steps:

- Remove Bolt 1 and 2
- Loosen the Caliper
- Remove Bolt 3 and 4
- Replace the Brake pad

CAUTION:

Do not reuse the drained brake fluid.

Tighten the bleed screw.



Bleed screw 3 and 4 :
18 Nm (1.8 m • kg)

- Install the Caliper Bolt 1 and 2



Bolt (brake caliper):
25 Nm (2.5 m • kg)



3. Inspect:
 - Brake fluid level
Refer to “BRAKE FLUID LEVEL INSPECTION” section.



4. Check:
 - Brake lever operation
A softy or spongy feeling → Bleed brake system.
Refer to “BRAKE SYSTEM AIR BLEEDING” section.

REAR BRAKE PAD INSPECTION AND REPLACEMENT

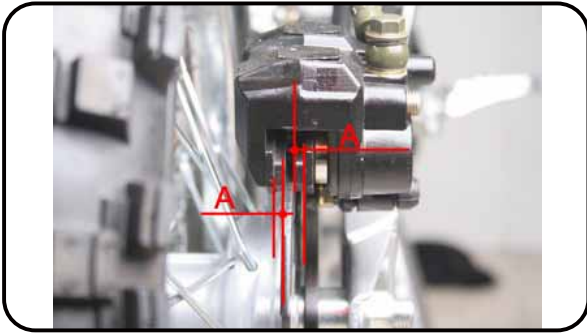

REAR BRAKE PAD INSPECTION AND REPLACEMENT

1. Inspect:

- Brake pad thickness A
Out of specification → Replace as a set.



Brake pad thickness:
4 mm
<Limit>: 1.0 mm



2. Replace:

- Brake pad

Brake pad replacement steps:

- Remove the Screw 1 and 2.
- Remove the Nut 3.
- Loosen the Caliper .
- Replace the Brake pad.



REAR BRAKE PAD INSPECTION AND REPLACEMENT



CAUTION:

Do not reuse the drained brake fluid.

- Tighten the bleed screw 1 and 2.



Bleed screw 1 and 2:
18 Nm (1.8m • kg)



Nut 3 (brake caliper):
20 Nm (2.0m • kg)

3. Inspect:
 - Brake fluid level
Refer to “BRAKE FLUID LEVEL INSPECTION” section.
4. Check:
 - Brake pedal operation
A softy or spongy feeling → Bleed brake system.
Refer to “BRAKE SYSTEM AIR BLEEDING” section.

BRAKE FLUID LEVEL INSPECTION

1. Place the brake master cylinder so that its top is in a horizontal position.
2. Inspect:
 - Brake fluid level
Fluid at lower level → Fill up.

a Lower level

A Front

B Rear



Recommended brake fluid:
DOT #3 or DOT #4

▲ WARNING

- Use only designated quality brake fluid to avoid poor brake performance.
- Refill with same type and brand of brake fluid; mixing fluids could result in poor brake performance.
- Be sure that water or other contaminants do not enter master cylinder when refilling.
- Clean up spilled fluid immediately to avoid erosion of painted surfaces or plastic parts.

SPROCKETS INSPECTION/DRIVE CHAIN INSPECTION

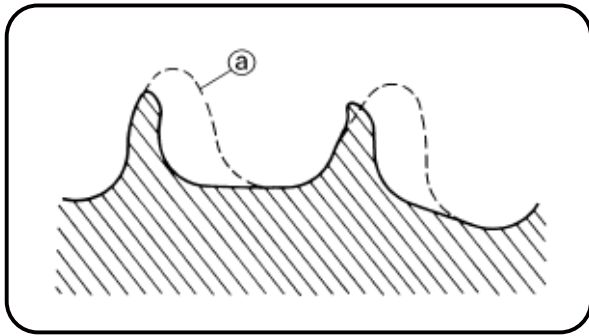

SPROCKETS INSPECTION

1. Inspect:
 - Sprocket teeth (a)
 Excessive wear → Replace.

NOTE:

Replace the drive sprocket, rear wheel sprocket and drive chain as a set.

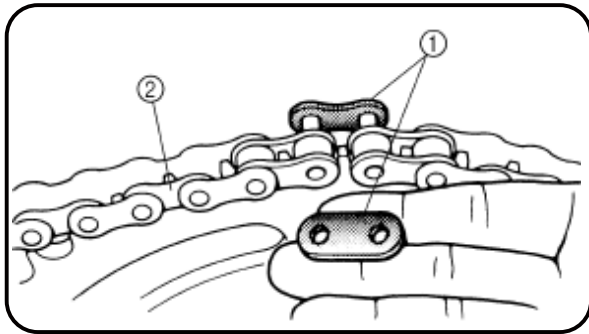

DRIVE CHAIN INSPECTION

1. Remove:
 - Master link clip
 - Joint (1)
 - Drive chain (2)

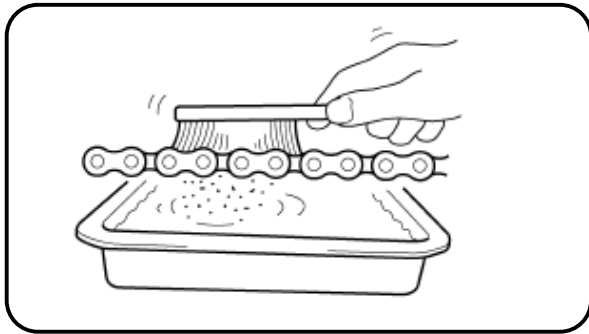

2. Clean:
 - Drive chain
 Place it in kerosene, and brush off as much dirt as possible. Then remove the drive chain from the kerosene and dry the drive chain.

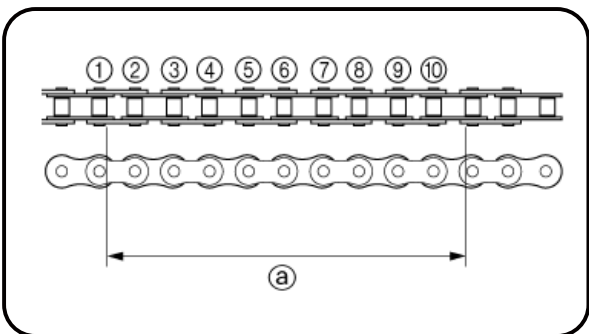

3. Measure:
 - Drive chain length (10 links) (a)
 Out of specification → Replace.



Drive chain length (10 links):
<Limit>: 144.4 mm

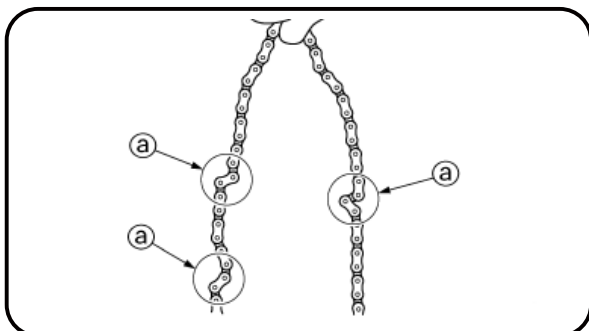

4. Check:
 - Drive chain stiffness (a)
 Clean and oil the drive chain and hold as illustrated.
 Stiff → Replace drive chain.

DRIVE CHAIN SLACK ADJUSTMENT

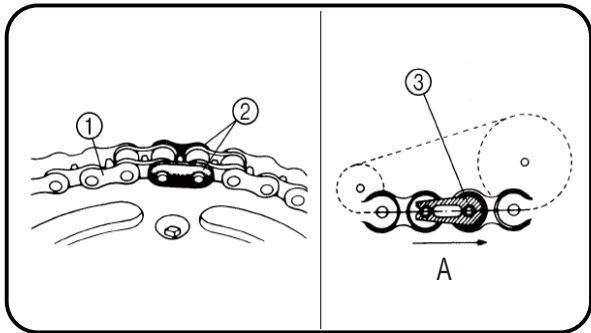

5. Install:

- Drive chain ①
- Joint ②
- Master link clip ③

CAUTION:

Be sure to install the master link clip to the direction as shown.

A Turning direction

6. Lubricate:

- Drive chain

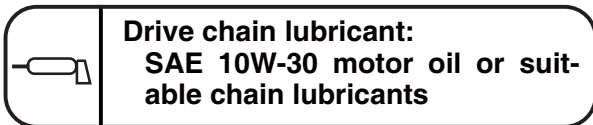

Drive chain lubricant:

SAE 10W-30 motor oil or suitable chain lubricants

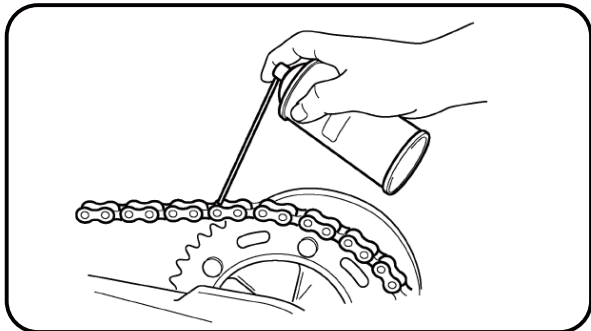

DRIVE CHAIN SLACK ADJUSTMENT

1. Elevate the rear wheel by placing the suitable stand under the engine.
2. Check:
 - Drive chain slack AAbove the seal guard installation bolt.
Out of specification → Adjust.



Drive chain slack:

30 ~ 50 mm

NOTE:

Before checking or adjusting, rotate the rear wheel through several revolutions and check the slack several times to find the tightest point. Check and/or adjust the drive chain slack with the rear wheel in this “tight chain” position.

FRONT FORK INSPECTION

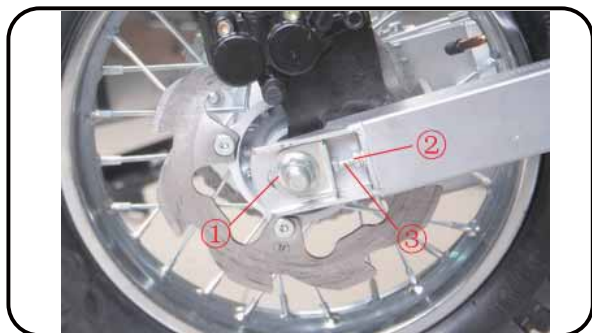

3. Adjust:
 - Drive chain slack

Drive chain slack adjustment steps:

- Loosen the axle nut and locknuts .
- Adjust the drive chain slack by turning the adjusters .

To tighten → Turn the adjuster **counterclockwise**.

To loosen → Turn the adjuster **clockwise and push wheel forward**.

- Turn each adjuster exactly the same amount to maintain correct axle alignment.

NOTE: _____
Turn the adjuster so that the drive chain is in line with the sprocket, as viewed from the rear.

CAUTION: _____
Too small drive chain slack will overload the engine and other vital parts; keep the slack within the specified limits.

- Tighten the axle nut while pushing down the drive chain.



Axle nut:
65 Nm (6.5 m • kg)

- Tighten the locknuts.



Locknut:
12 Nm (1.2 m • kg)



FRONT FORK INSPECTION

1. Inspect:
 - Front fork smooth action
Operate the front brake and stroke the front fork.
Unsmooth action/oil leakage → Repair or replace.

CHECKING THE BATTERY



ELECTRICAL SYSTEM CHECKING THE BATTERY

⚠ WARNING

Batteries generate explosive hydrogen gas and contain electrolyte which is made of poisonous and highly caustic sulfuric acid. Therefore, always follow these preventive measures:

- Wear protective eye gear when handling or working near batteries.
- Charge batteries in a well-ventilated area.
- Keep batteries away from fire, sparks or open flames (e.g., welding equipment, lighted cigarettes).
- DO NOT SMOKE when charging or handling batteries.
- KEEP BATTERIES AND ELECTROLYTE OUT OF REACH OF CHILDREN.
- Avoid bodily contact with electrolyte as it can cause severe burns or permanent eye injury.

First aid in case of bodily contact:

External

- SKIN – Wash with water.
- EYES – Flush with water for 15 minutes and get immediate medical attention.

Internal

- Drink large quantities of water or milk followed with milk of magnesia, beaten egg or vegetable oil. Get immediate medical attention.



1. Disconnect:
 - battery leads (from the battery terminals)

CAUTION: _____

First, disconnect the negative lead ①, then the positive lead ②.



2. Remove:
 - Screw (Battery bracket) :

CHECKING THE BATTERY

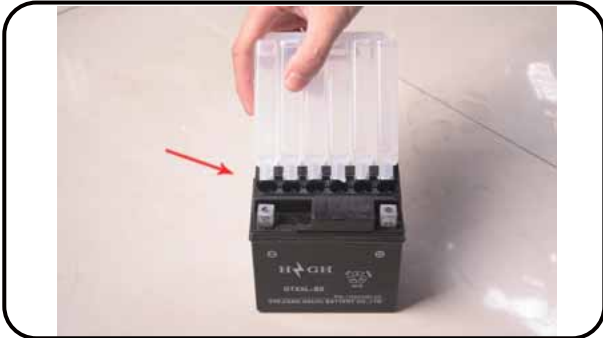

NOTE:

Replace the battery whenever:

- battery voltage does not rise to specification or bubbles fail to rise during charging,
- sulphation of one or more battery cells occurs (as indicated by the battery plates turning white or material accumulating in the bottom of the battery cell),
- specific gravity readings after a long, slow charge indicate that one battery cell's charge is lower than the rest,
- warpage or buckling of the battery plates or insulators is evident.

CAUTION:

Add only distilled water. Tap water contains minerals which are harmful to the battery.

3. Charge:

- battery

Battery charging amperage and time
0.4 amps/10 hrs

⚠ WARNING

Do not quick charge a battery.

CAUTION:

- To ensure maximum performance, always charge a new battery before using it.
- Do not use a high-rate battery charger. They force a high-amperage current into the battery quickly and can cause battery overheating and battery plate damage.
- If it is impossible to regulate the charging current on the battery charger, be careful not to overcharge the battery.
- When charging a battery, be sure to remove it from the motorcycle. (If charging has to be done with the battery mounted on the motorcycle, disconnect the negative lead from the battery terminal.)
- To reduce the chance of sparks, do not plug in the battery charger until the battery charger leads are connected to the battery.
- Before removing the battery charger lead clips from the battery terminals, be sure to turn off the battery charger.
- Make sure that the battery charger lead clips are in full contact with the battery terminal and that they are not shorted. A corroded battery charger lead clip may generate heat in the contact area and a weak clip spring may cause sparks.
- If the battery becomes hot to the touch at any time during the charging process, disconnect the battery charger and let the battery cool before reconnecting it. Hot batteries can explode!

REAR SHOCK ABSORBER SPRING PRELOAD ADJUSTMENT



REAR SHOCK ABSORBER SPRING PRELOAD ADJUSTMENT

1. Elevate the rear wheel by placing the suitable stand under the engine.
2. Remove:
 - Rear frame
3. Loosen:
 - Locknut
4. Adjust:
 - Spring preload
 By turning the adjuster .

Stiffer → Increase the spring preload.
(Turn the adjuster in.)

Softer → Decrease the spring preload.
(Turn the adjuster out.)



Spring length (installed) A :

Standard length	Extent of adjustment
140 mm	135 ~ 140 mm



* For EUROPE

NOTE:

- Be sure to remove all dirt and mud from around the locknut and adjuster before adjustment.
- The length of the spring (installed) changes 1.5 mm (0.06 in) per turn of the adjuster.

CAUTION:

Never attempt to turn the adjuster beyond the maximum or minimum setting.

5. Tighten:
 - Locknut
6. Install:
 - Rear frame (upper)

🔩 40 Nm (4 m • kg)

 - Rear frame (lower)

🔩 40 Nm (4 m • kg)

TIRE PRESSURE CHECK/SPOKES INSPECTION AND TIGHTENING/WHEEL INSPECTION



TIRE PRESSURE CHECK

1. Measure:
 - Tire pressure
 - Out of specification → Adjust.



Standard tire pressure:
130 kPa (1.3 kgf/cm²)

NOTE:

- Check the tire while it is cold.
- Loose bead stoppers allow the tire to slip off its position on the rim when the tire pressure is low.
- A tilted tire valve stem indicates that the tire slips off its position on the rim.
- If the tire valve stem is found tilted, the tire is considered to be slipping off its position. Correct the tire position.



SPOKES INSPECTION AND TIGHTENING

1. Inspect:
 - Spokes
 - Bend/damage → Replace.
 - Loose spoke → Retighten.
2. Tighten:
 - Spokes  **3 Nm (0.3 m · kg)**

NOTE:

Be sure to retighten these spokes before and after break-in. After a practice or a race check spokes for looseness.



WHEEL INSPECTION

1. Inspect:
 - Wheel runout
 - Elevate the wheel and turn it.
 - Abnormal runout → Replace.

STEERING HEAD INSPECTION AND ADJUSTMENT



2. Inspect:
 - Bearing free play
 - Exist play → Replace.



STEERING HEAD INSPECTION AND ADJUSTMENT

1. Elevate the front wheel by placing a suitable stand under the engine.
2. Check:
 - Steering stem
Grasp the bottom of the forks and gently rock the fork assembly back and forth.
Free play → Adjust steering head.
3. Check:
 - Steering smooth action
Turn the handlebar lock to lock.
Unsmooth action → Adjust steering ring nut.

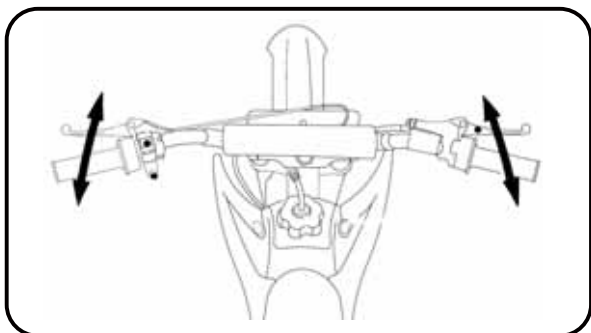

4. Adjust:
 - Steering ring nut

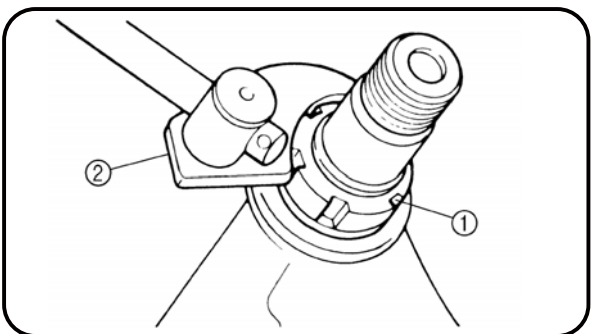

Steering ring nut adjustment steps:

- Remove the number plate.
- Remove the handlebar and handlebar upper bracket.
- Loosen the steering ring nut using the steering nut wrench (2).

STEERING HEAD INSPECTION AND ADJUSTMENT

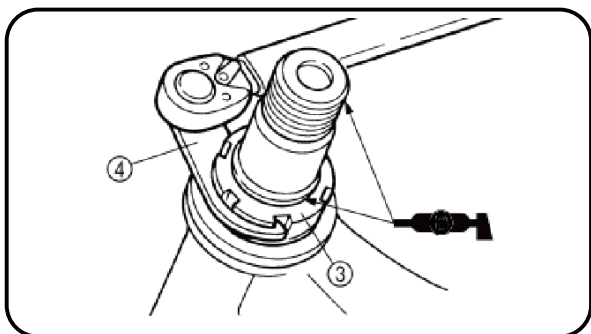

- Tighten the steering ring nut using steering nut wrench (4).

NOTE:

- Apply the lithium soap base grease on the thread of the steering stem.
- Set the torque wrench to the steering nut wrench so that they form a right angle.



Steering ring nut (initial tightening):
30 Nm (3 m • kg)

- Loosen the steering ring nut one turn.
- Retighten the steering ring nut using the steering nut wrench.

⚠ WARNING

Avoid over-tightening.

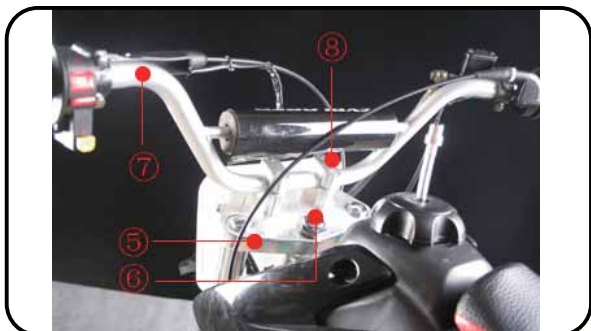

- Check the steering stem by turning it lock to lock. If there is any binding, remove the steering stem assembly and inspect the steering bearings.
- Install the upper bracket, washer, steering stem nut, handlebar, handlebar upper holder.

CAUTION:

First tighten the bolts on the front side of the handlebar holder, and then tighten the bolts on the rear side.



Steering stem nut:
70 Nm (7 m • kg)
Handlebar upper holder:
25 Nm (2.5 m • kg)

ELECTRICAL/SPARK PLUG INSPECTION

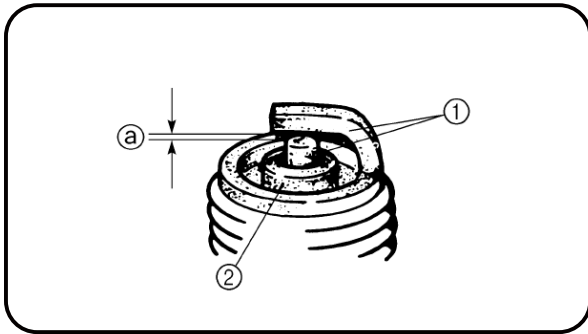

ELECTRICAL

SPARK PLUG INSPECTION

1. Remove:
 - Spark plug
2. Inspect:
 - Electrode
Wear/damage → Replace.
 - Insulator color
Normal condition is (a) medium to light tan color.
Distinctly different color → Check the engine condition.

NOTE:

When the engine runs for many hours at low speeds, the spark plug insulator will become sooty, even if the engine and carburetor are in good operating condition.

3. Measure:
 - Plug gap (a)
Use a wire gauge or thickness gauge.
Out of specification → Regap.



Spark plug gap:
0.6 ~ 0.7 mm

4. Clean the plug with a spark plug cleaner if necessary.

5. Tighten:
 - Spark plug

 **15 Nm (1.5 m • kg)**

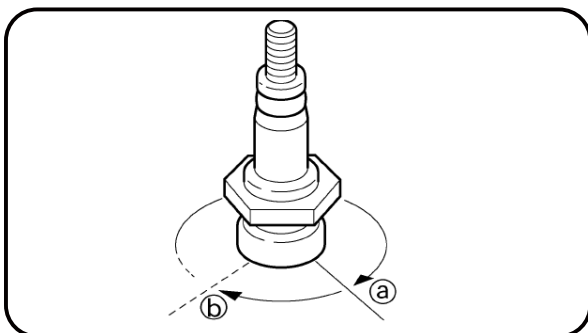

NOTE:

- Before installing a spark plug, clean the gasket surface and plug surface.
- Finger-tighten (a) the spark plug before torquing to specification (b).

IGNITION TIMING CHECK

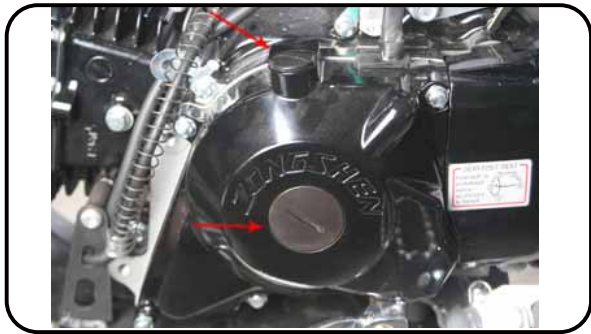

IGNITION TIMING CHECK

1. Remove:
 - Timing mark accessing screw

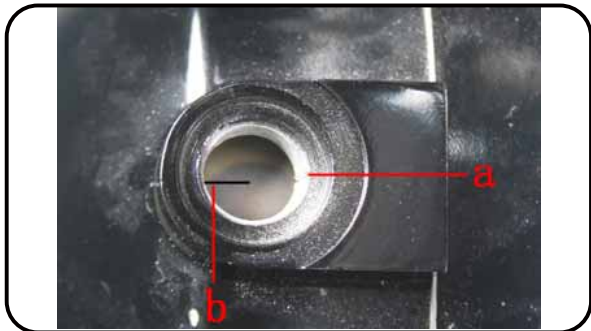

2. Check:
 - Ignition timing

Checking steps:

- Start the engine and let it warm up. Let the engine run at the specified speed.



Engine speed:
1,400 ~ 1,600 r/min

- Visually check the stationary pointer **a** is within the firing range **b** on the rotor.
Incorrect firing range → Check rotor and pickup assembly.



3. Install:
 - Timing mark accessing screw



ENGINE SEAT, FUEL TANK AND SIDE COVERS

SEAT, FUEL TANK AND SIDE COVERS

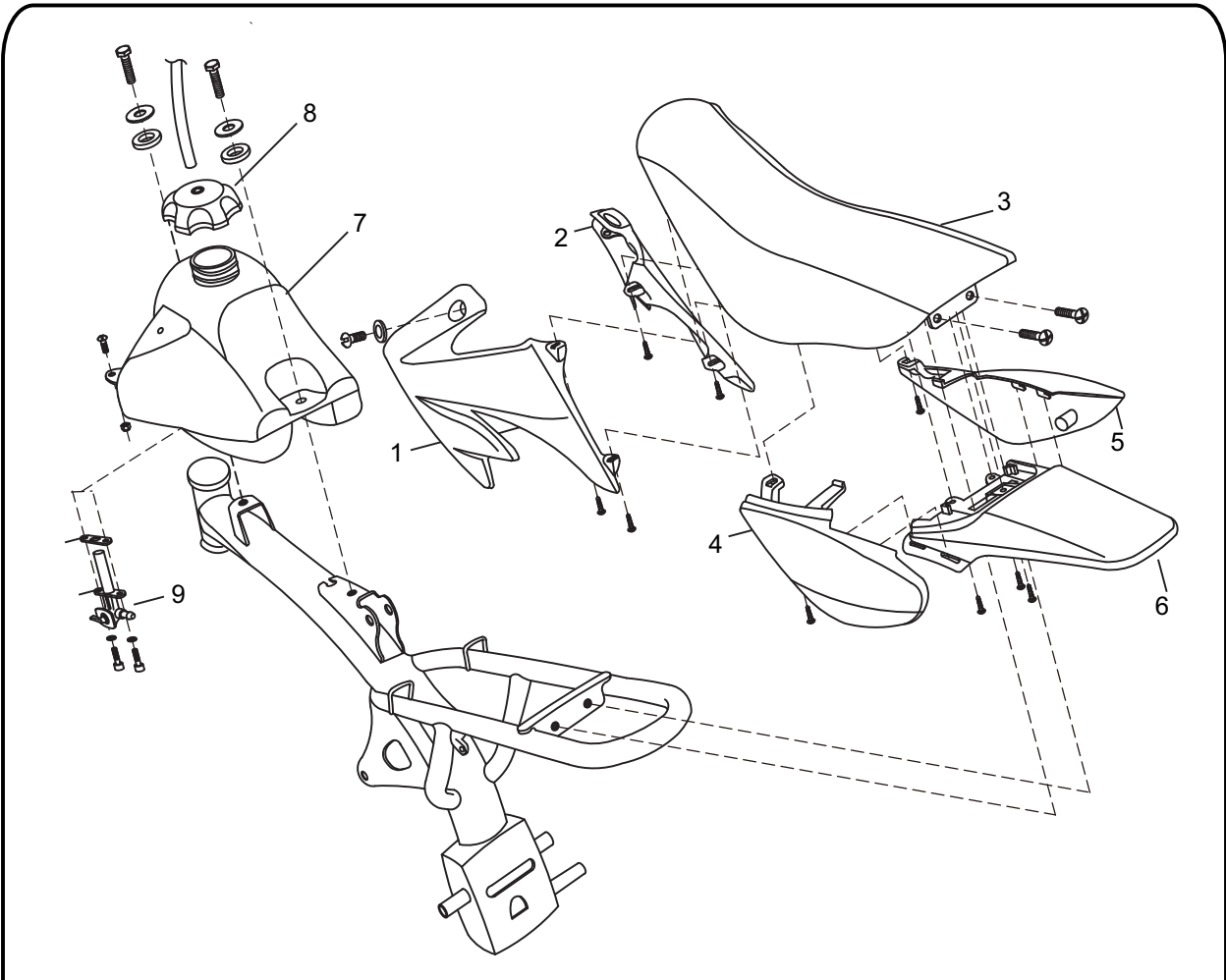

Order	Job / Part name	Q'ty	Remarks
			Remove the parts in the order listed.
1	LEFT TANK COVER	1	
2	RIGHT TANK COVER	1	
3	SEAT	1	
4	LEFT FENDER PLATE	1	
5	RIGHT FENDER PLATE	1	
6	TAIL FENDER	1	
7	FUEL TANK	1	
8	FUEL CAP	1	
9	PET-COCK	1	
			For installation, reverse the removal procedure.

SEAT, FUEL TANK AND SIDE COVERS

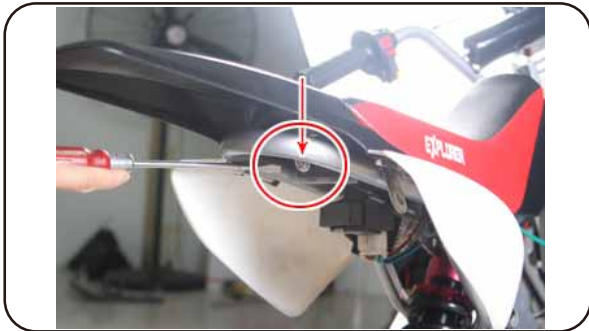

REMOVAL POINTS

Fuel Tank , Side covers and Seat

Remove:

- Bolt for Tank Cover
- Seat Bolt
- Bolt for Fuel Tank
- Fuel Tank
- Screw for Tank Cover and Seat
- Left Tank Cover
- Right Tank Cover
- Screw for Fender plate
- Left Fender plate
- Right Fender plate
- Screw for Fender plate
- Seat

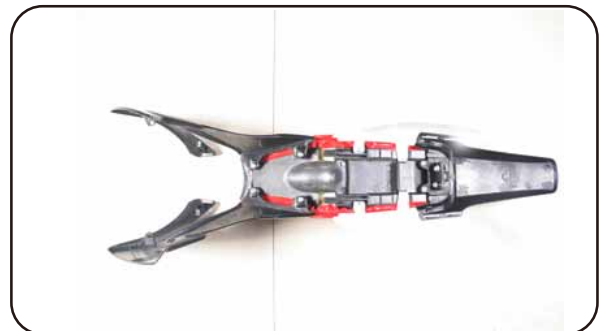

EXHAUST PIPE AND SILENCER

EXHAUST PIPE AND SILENCER

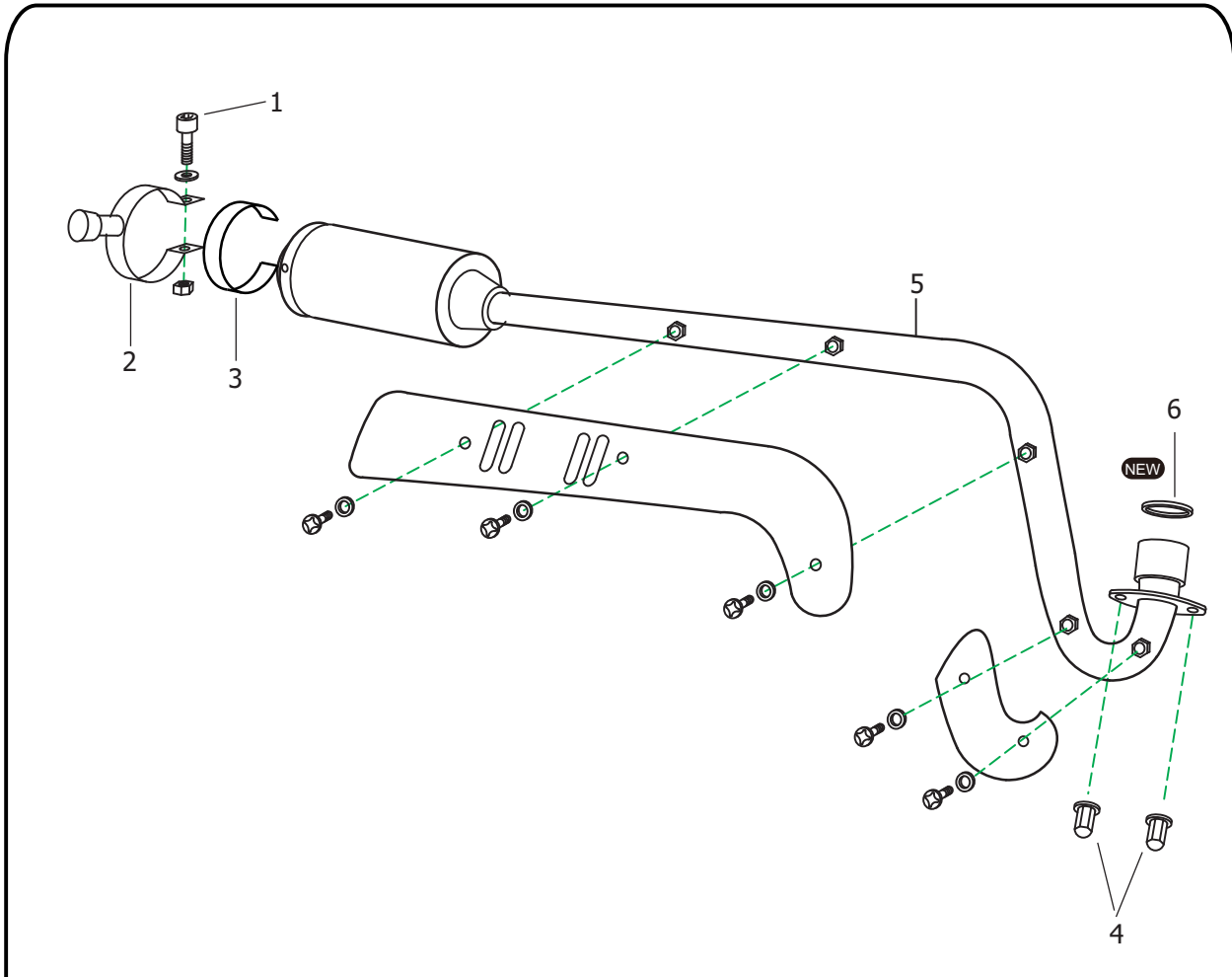

Order	Job / Part name	Q'ty	Remarks
1	BOLT	1	Remove the parts in the order listed.
2	HOOP	1	
3	RUBBER MAT	1	
4	NUT M6×14	2	
5	EXHAUST MUFFLER	1	
6	EXHAUST PIPE SEAL	1	
			For installation, reverse the removal procedure.

EXHAUST PIPE AND SILENCER

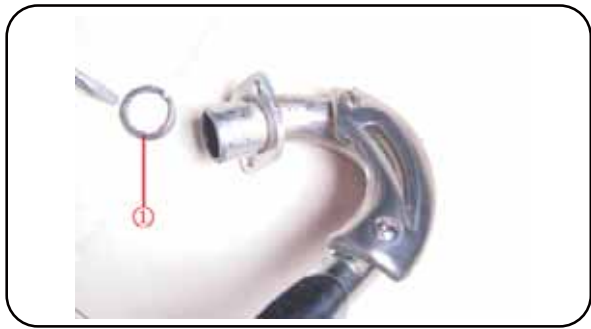

INSPECTION

Silencer and exhaust pipe

1. Inspect:
 - GasketDamage → Replace.



ASSEMBLY AND INSTALLATION

Silencer and exhaust pipe

1. Install:
 - Gasket
 - Exhaust muffler
 - Nut ② (exhaust pipe)

 15 Nm (1.5 m • kg)



2. Install:

- Washer
- Bolt (silencer)

 25 Nm (2.5 m • kg)



NOTE:

First, temporarily tighten the Nut ① (exhaust pipe), then tighten the bolt ②

CRBURETOR & AIR-FITER

CRBURETOR & AIR-FITER

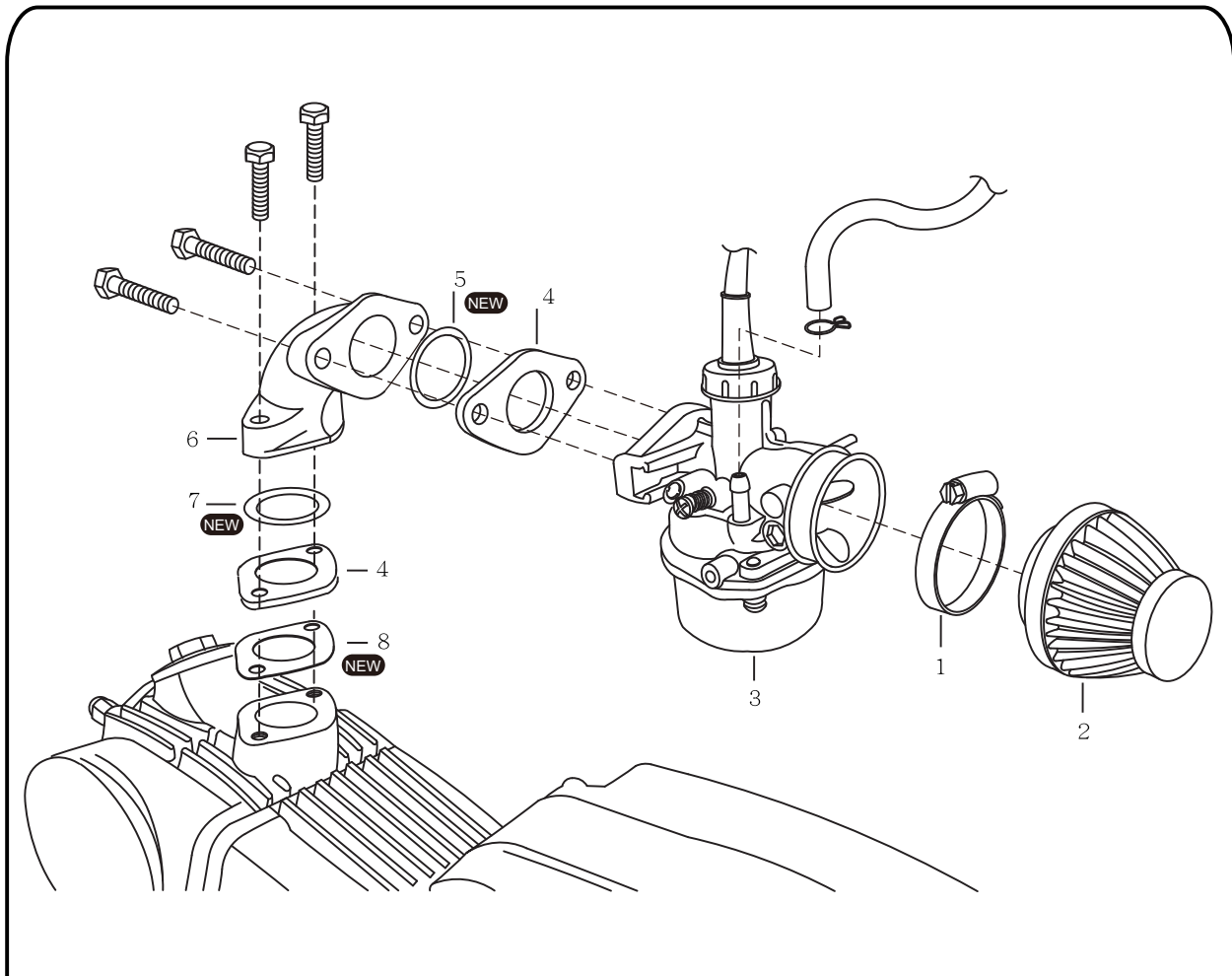

Order	Job / Part name	Q'ty	Remarks
			Remove the parts in the order listed.
1	SCREW FOR AIR-FITER CLAMP	1	
2	AIR-FITER	1	
3	CRBURETOR	1	
4	GASKET,HEAT INSULATING, CRBURETOR	2	
5	O-RING	1	
6	INLET PIPE	1	
7	O-RING	1	
8	GASKET	1	
			For installation, reverse the removal procedure.

CARBURETOR DISASSEMBLY

CARBURETOR DISASSEMBLY

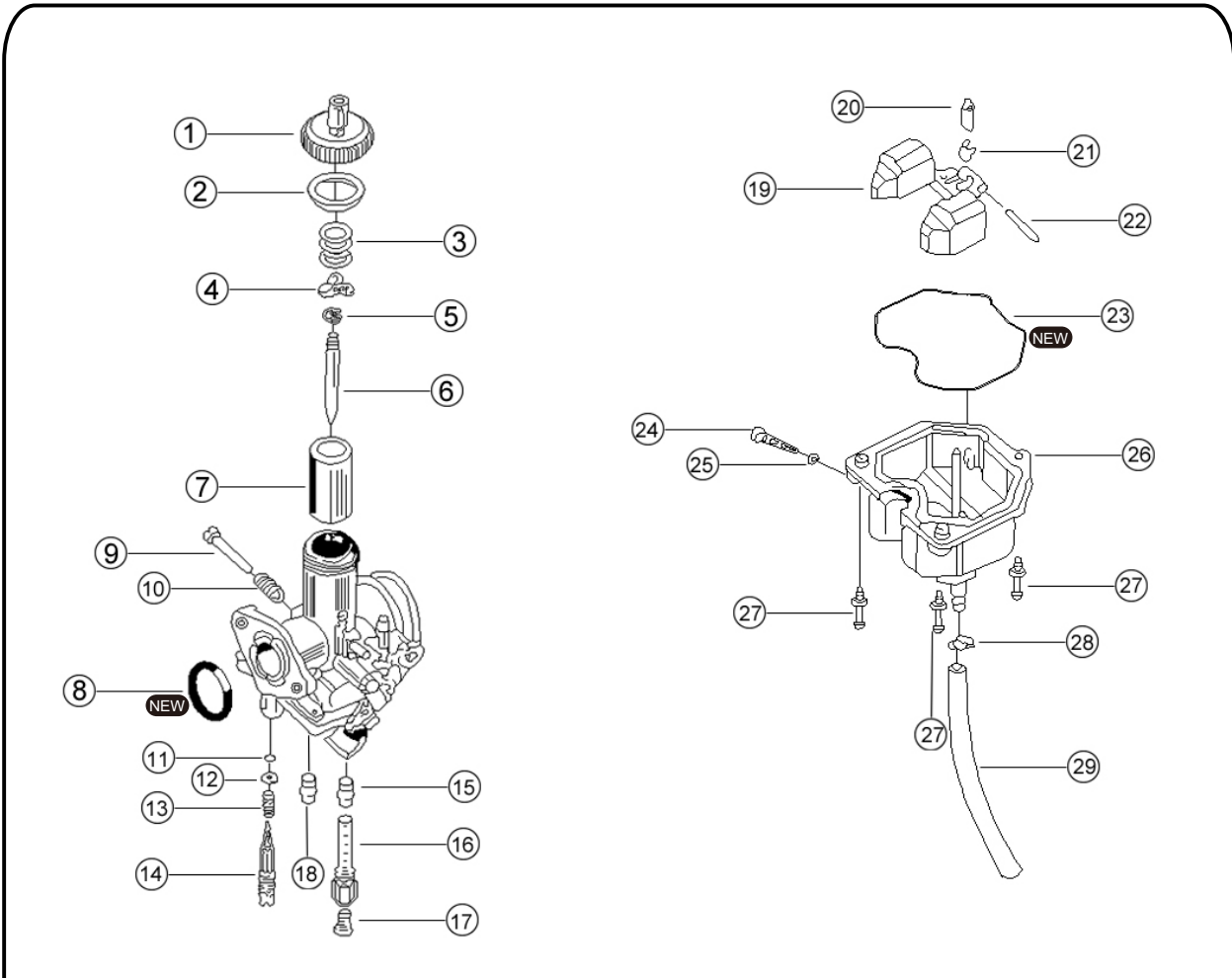

Order	Job / Part name	Q'ty	Remarks
			Remove the parts in the order listed.
1	UPPER COVER	1	
2	GASKET,UPPER COVER	1	
3	RETURN SPRING,AIR THROTTLE	1	
4	V-CLIP	1	
5	E-CIRCLIP	1	
6	NEEDLE,JET	1	
7	AIR THROTTLE	1	
8	O-RING	1	
9	ADJUSTING SCREW,AIR THROTTLE	1	
10	SPRING,ADJUSTING SCREW	1	
11	O-RING	1	
12	WASHER	1	
13	ADJUSTING SCREW SPRING	1	
14	IDLE FOAM JET	1	
15	MAIN JET,OIL	1	
16	MAIN JET,FOAM	1	
17	MAIN MEASURING HOLE	1	
18	IDLE JET	1	
			For installation, reverse the removal procedure.

CARBURETOR DISASSEMBLY

CARBURETOR DISASSEMBLY

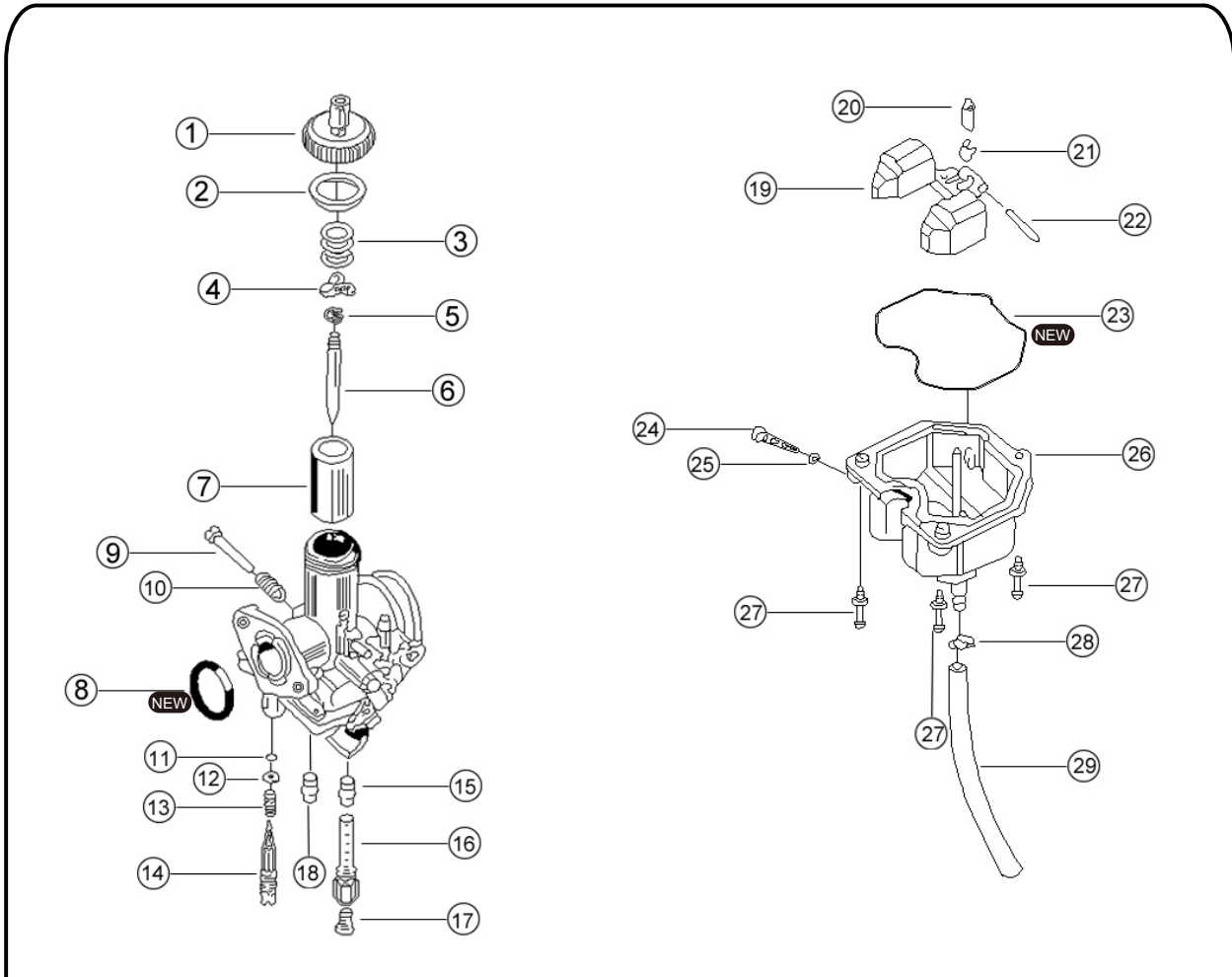

Order	Job / Part name	Q'ty	Remarks
19	FLOAT COMP	1	Remove the parts in the order listed.
20	NEEDLE VALVE,CARBURETOR FLOAT	1	
21	HOOK,NEEDLE VALVE	1	
22	FLOAT PIN	1	
23	GASKET,FLOAT CHAMBER	1	
24	DRAIN SCREW	1	
25	O-RING	3	
27	SCREW UNIT,FLOAT CHAMPER	1	
28	PIPE CLIP	1	
29	HOSE	1	
			For installation, reverse the removal procedure.

CARBURETOR



INSPECTION

Carburetor

- Inspect:
 - Carburetor body
Contamination → Clean.

NOTE:

- Use a petroleum based solvent for cleaning. Blow out all passages and jets with compressed air.
- Never use a wire.

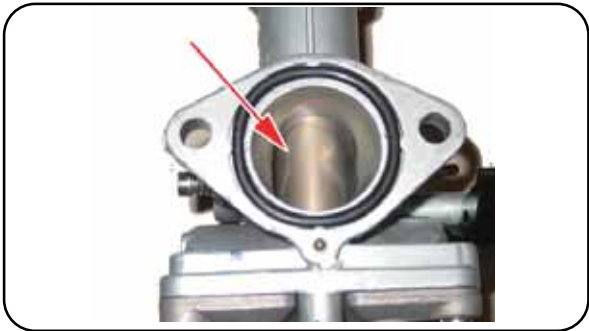

- Inspect:
 - Adjust Screw, Mixture
 - Idle Jet
 - Main Measuring Hole and Main Nozzle
 - Main Jet
 - Drain Screw

Damage → Replace.
Contamination → Clean.

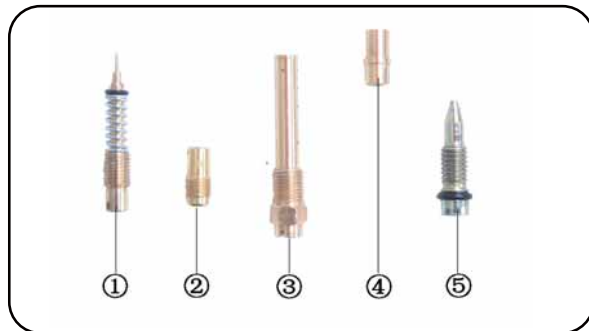

NOTE:

- Use a petroleum based solvent for cleaning. Blow out all passages and jets with compressed air.
- Never use a wire.

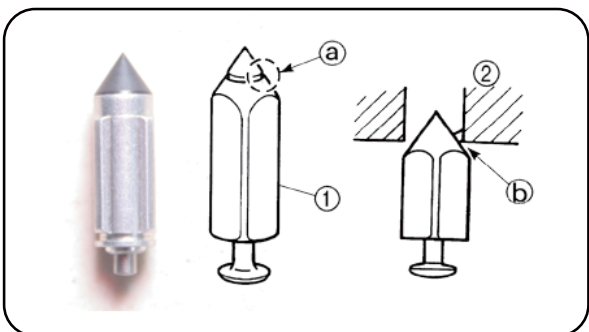

Needle valve

- Inspect:
 - Needle valve
 - Valve seat
- Grooved wear (a) → Replace.
Dust (1) → Clean.

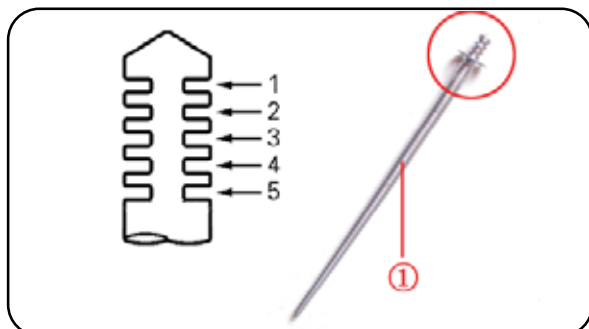

Jet needle

- Inspect:
 - Jet needle
Bends/wear → Replace.
 - Clip groove
Free play exists/wear → Replace.
 - Clip position

**Standard clip position:
No.4 Groove**

SPROCKET REPLACEMENT

SPROCKET REPLACEMENT

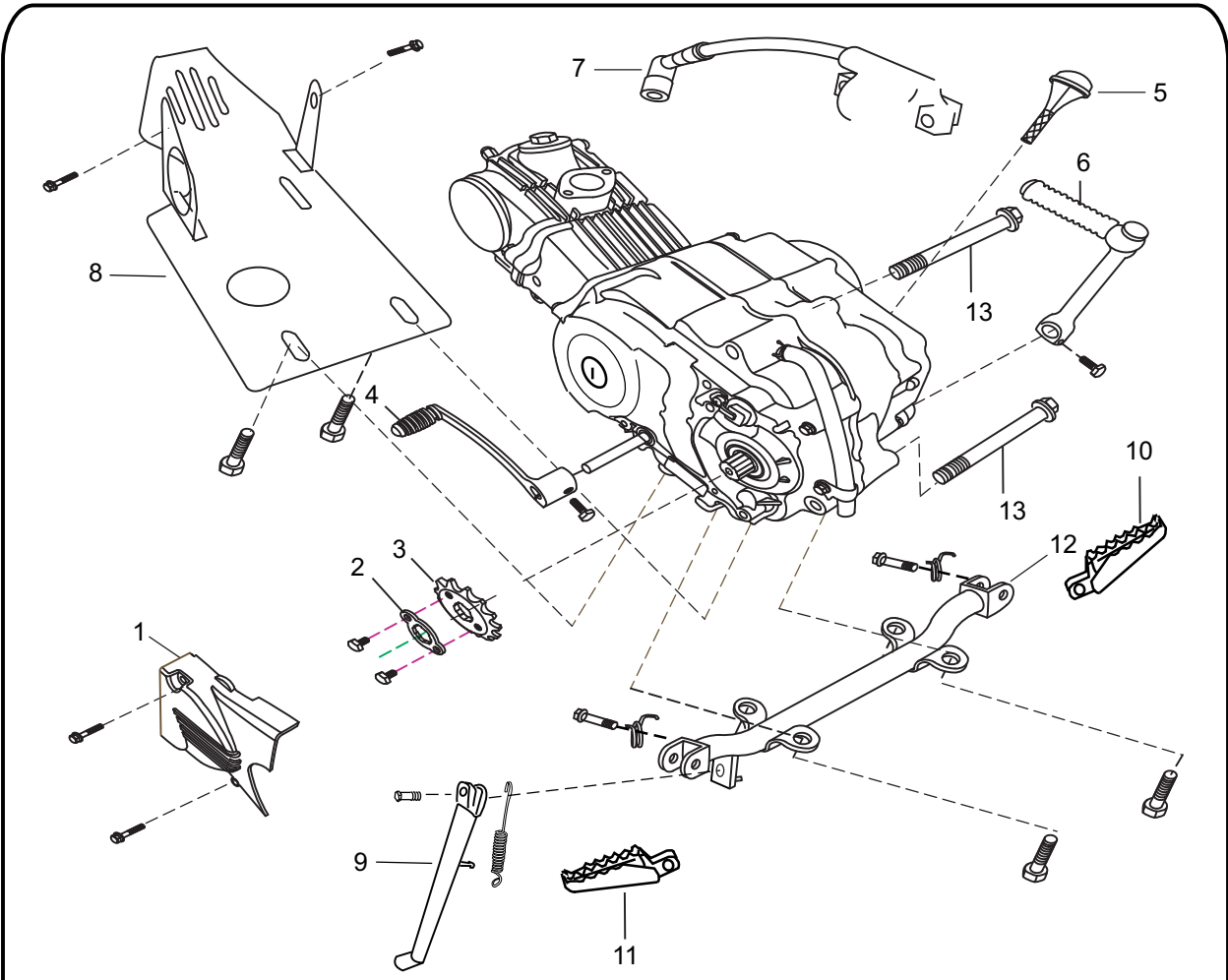

Order	Job / Part name	Q'ty	Remarks
			Remove the parts in the order listed.
1	COVER, L. RR. CRANKCASE	1	
2	INITIATIVE CHAIN DRIVER RIVET	1	
3	DRIVING GEAR	1	
4	SHIFT PEDAL	1	
5	GUAGE OIL LEVER	1	
6	KICK STARTER	1	
7	SPARK PLUG CAP	1	
8	ENGINE SKID PLATE	1	
9	SIDE STAND	1	
10	RIGHT FOOT PAPS	1	
11	LEFT FOOT PEGS	1	
12	BRACKET FOR PEDAL	1	
13	AXLE	2	
			For installation, reverse the removal procedure.

CYLINDER HEAD

CYLINDER HEAD

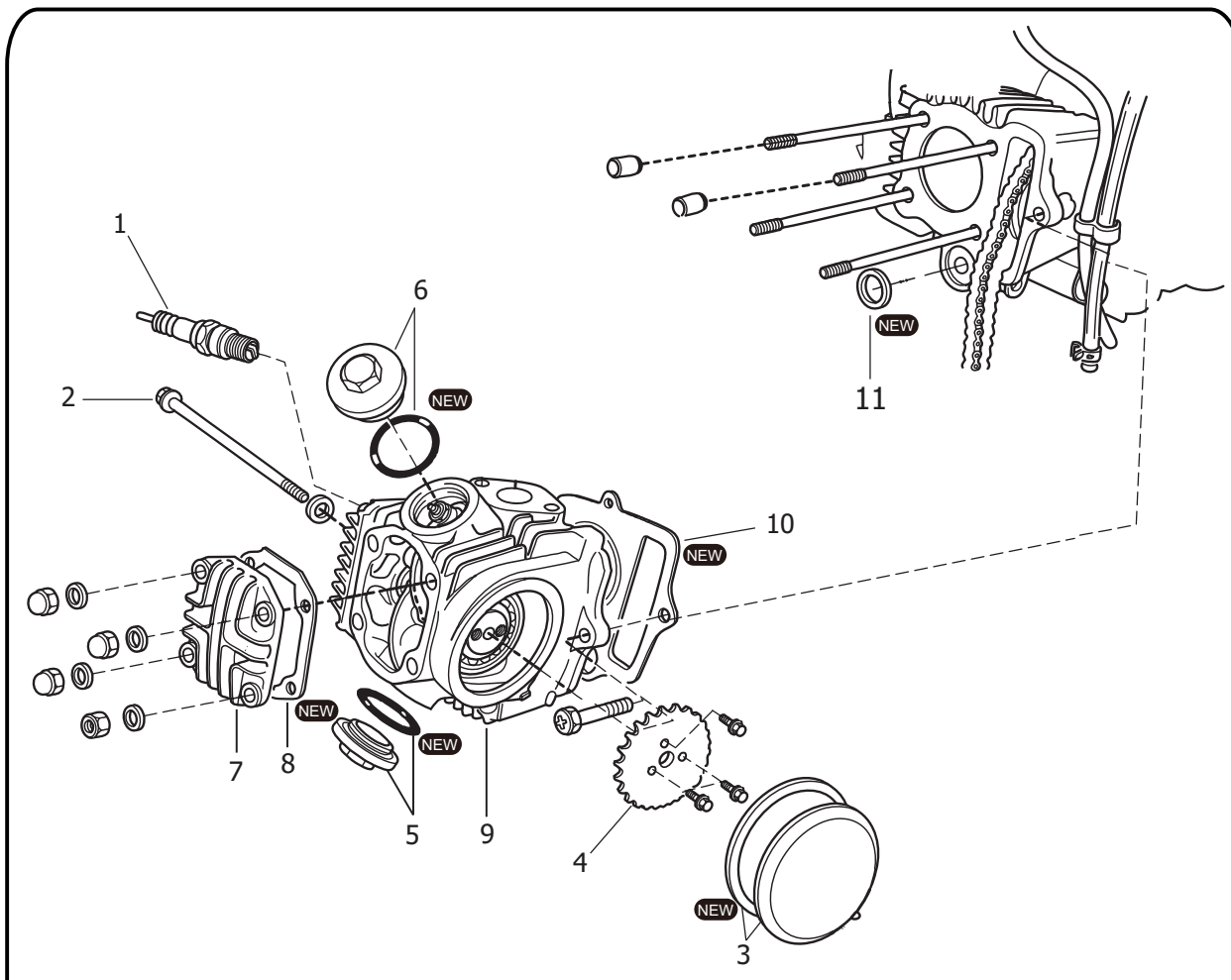

Order	Job / Part name	Q'ty	Remarks
			Remove the parts in the order listed.
1	Spark plug	1	
2	Bolt M6 x 110	1	
3	Cylinder cover L / Gasket	1	
4	Timing driven sprocket	1	
5	Valve cover / O-ring	1	
6	Valve cover / O-ring	1	
7	Cylinder cover	1	
8	Gasket,cylinder cover	1	
9	Cylinder head	1	
10	Gasket,cylinder head	1	
11	Rectangle ring	1	
			For installation, reverse the removal procedure.

CYLINDER HEAD



5 Remove Chain Tensioner



- Bolt ①
- Washer ②
- Spring Chain Tensioner Push Road
- Chain Tensioner Push Road Assembly

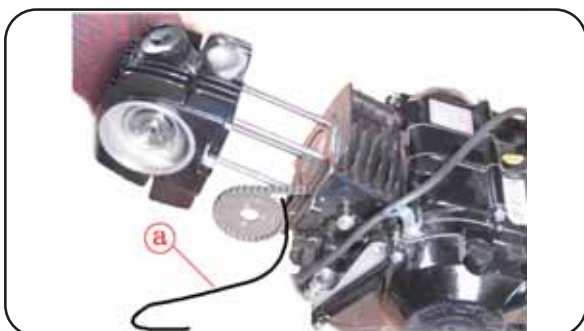
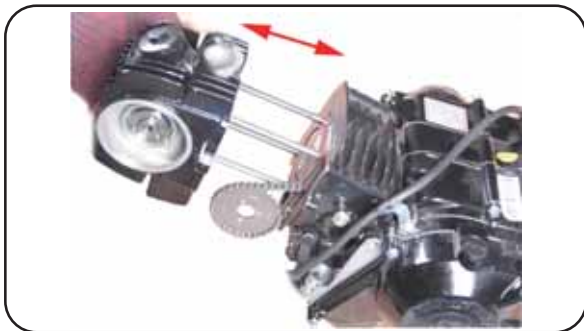

- NOTE:** _____
- To prevent the timing chain from falling into the crankcase, fasten it with a wire (a).
 - While holding the generator rotor bolt with a wrench, remove the bolt.
- _____

CYLINDER HEAD



CHECKING THE TIMING CHAIN TENSIONER

1. Check:
 - timing chain tensioner ①
 - Cracks/damage → Replace.

CHECKING THE TAPPET COVERS AND CAMSHAFT SPROCKET COVER

The following procedure applies to both of the tappet covers and O-rings.

1. Check:
 - tappet cover • camshaft sprocket cover
 - O-ring
 - Damage/wear → Replace the defective part(-s).

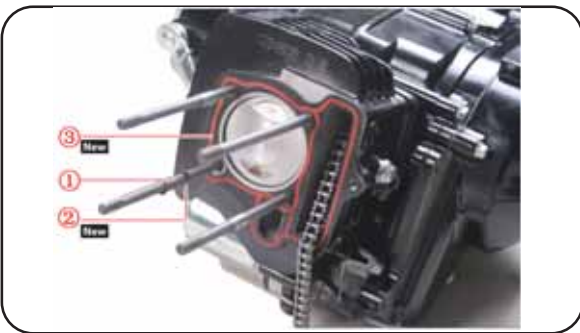

INSTALLING THE CYLINDER HEAD

1. Install:
 - dowel pins ①
 - O-ring (New) ②
 - gasket (New) ③

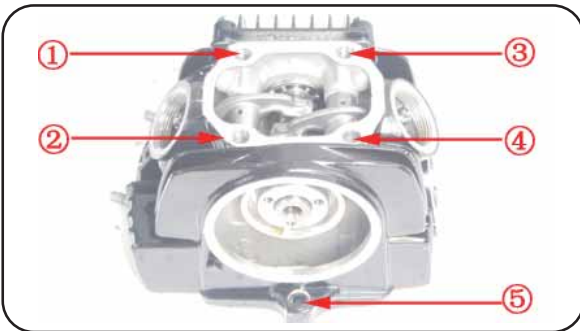

2. Install:
 - cylinder head

NOTE:

- Apply engine oil onto the threads of the cylinder head nuts.
- Tighten the cylinder head nuts in the proper tightening sequence as shown and torque them in two stages.



Cylinder head nut and bolt

M7 (① ~ ④) 15Nm

M6 (⑤) 10Nm

M6 (⑥) 10Nm

M6 (⑦) 10Nm

M30 (⑧) 20Nm

CAMSHAFT /VALVES AND VALVE SPRINGS

CAMSHAFT /VALVES AND VALVE SPRINGS

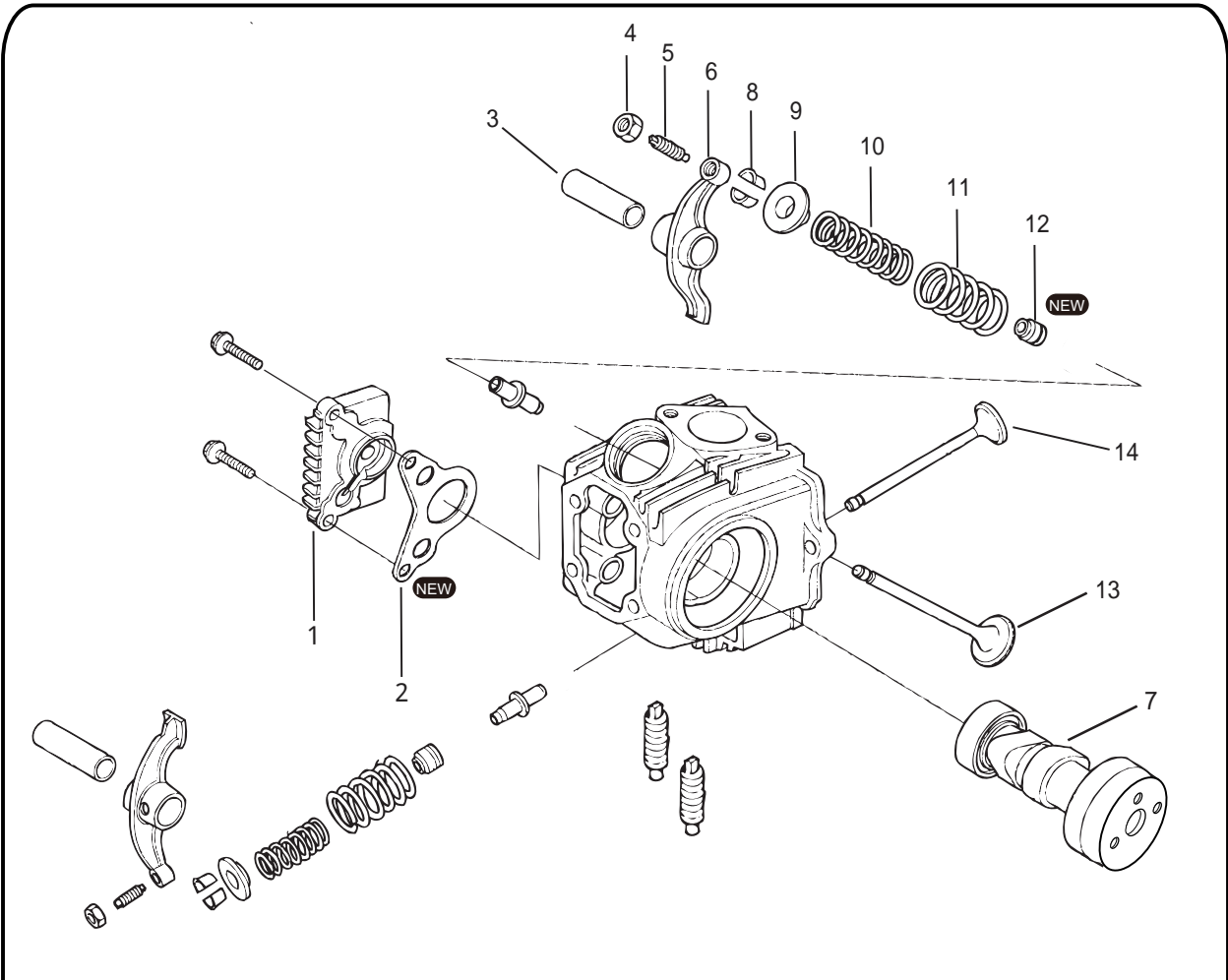

Order	Job / Part name	Q'ty	Remarks
			Remove the parts in the order listed.
1	RIGHT COVER,CYLINDER HEAD	1	
2	GASKET	1	
3	SHAFT,VALVE RROCKER ARM	2	
4	ADJUSTING NUT	2	
5	ADJUSTING SCREW	2	
6	VALVE RROCKER ARM	2	
7	CAM SHAFT	1	
8	VALVE COTTER	4	
9	PETAINER,VALVE SPRING	2	
10	VALVE INNER SPRING	2	
11	VALVE OUTER SPRING	2	
12	VALVE STEM SEAL	2	
13	INTAKE VALVE	1	
14	EXHAUST VALVE	1	

For installation, reverse the removal procedure.

CAMSHAFT /VALVES AND VALVE SPRINGS



REMOVING THE ROCKER ARMS AND CAM-SHAFT

1. Loosen:
 - locknuts ①
 - adjusting screws ②

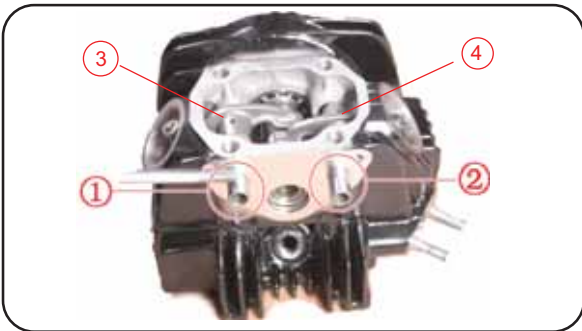

2. Remove:
 - intake rocker arm shaft
 - exhaust rocker arm shaft
 - intake rocker arm ③
 - exhaust rocker arm ④



3. Remove:
 - camshaft ①



CHECKING THE CAMSHAFTS

1. Check:
 - camshaft bushings
Damage/wear → Replace.
 - camshaft lobes
Blue discoloration/pitting/scratches →
Replace the camshaft.

CAMSHAFT /VALVES AND VALVE SPRINGS

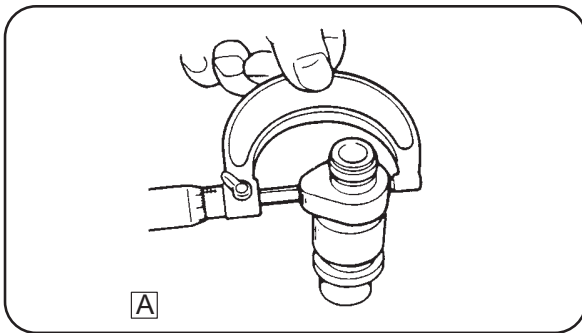

2. Measure:
- camshaft lobe dimensions **A**
Out of specification → Replace the camshaft.

	Camshaft lobe dimension limit
	Intake 26.30 mm
	Exhaust 26.00 mm

3. Check:
- camshaft oil passage
Obstruction → Blow out with compressed air.

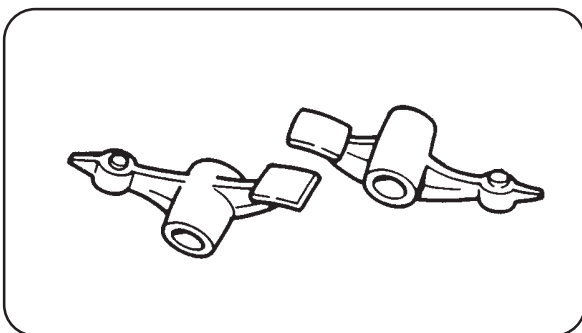

CHECKING THE ROCKER ARMS AND ROCKER ARM SHAFTS

The following procedure applies to all of the rocker arms and rocker arm shafts.

1. Check:
 - rocker arm
Damage/wear → Replace.
2. Check:
 - rocker arm shaft
Blue discoloration/excessive wear/pitting/scratches → Replace or check the lubrication system.
3. Check:
 - camshaft lobe
Excessive wear → Replace the camshaft.
4. Measure:
 - rocker arm inside diameter
Out of specification → Replace.

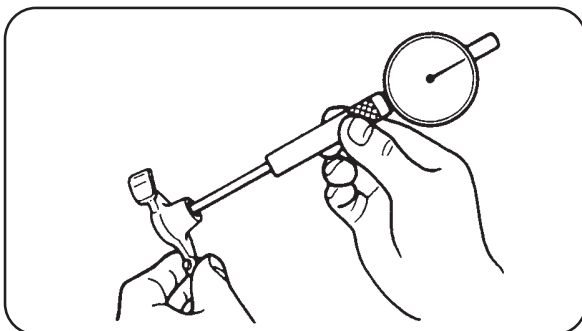

	Rocker arm inside diameter
	10.000 ~ 10.015 mm Limit 10.1 mm

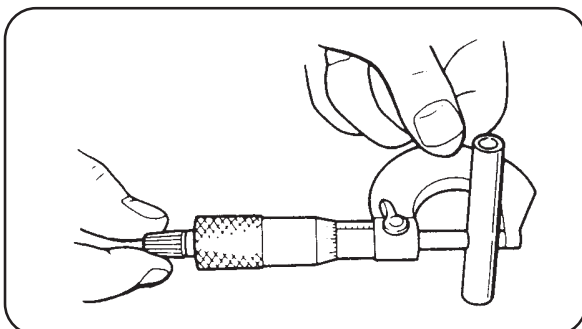

5. Measure:
- rocker arm shaft outside diameter
Out of specification → Replace.

	Rocker arm shaft outside diameter
	9.98 ~ 9.995 mm Limit 9.910 mm

CAMSHAFT /VALVES AND VALVE SPRINGS

6. Calculate:

- rocker-arm-to-rocker-arm-shaft clearance

NOTE:

Calculate the clearance by subtracting the rocker arm shaft outside diameter from the rocker arm inside diameter.

Out of specification → Replace the defective part(-s).

	<p>Rocker-arm-to-rocker-arm-shaft clearance 0.005 ~ 0.035 mm</p>
---	---

INSTALLING THE CAMSHAFT AND ROCKER ARMS

1. Lubricate:

- rocker arm shaft

	<p>Recommended lubricant Molybdenum disulfide oil</p>
---	--

2. Install:

- exhaust rocker arm ④
- exhaust rocker arm shaft ②

NOTE: _____

Make sure that the exhaust rocker arm shaft is completely pushed into the cylinder head.



3. Install:

- intake rocker arm ③
- intake rocker arm shaft ①

NOTE: _____

Insert the camshaft into the hole in the cylinder head and the intake rocker arm shaft as shown .

4. Lubricate:

- Camshaft

	<p>Recommended lubricant Camshaft Molybdenum disulfide oil Camshaft bearing Engine oil</p>
---	---

CAMSHAFT / VALVES AND VALVE SPRINGS

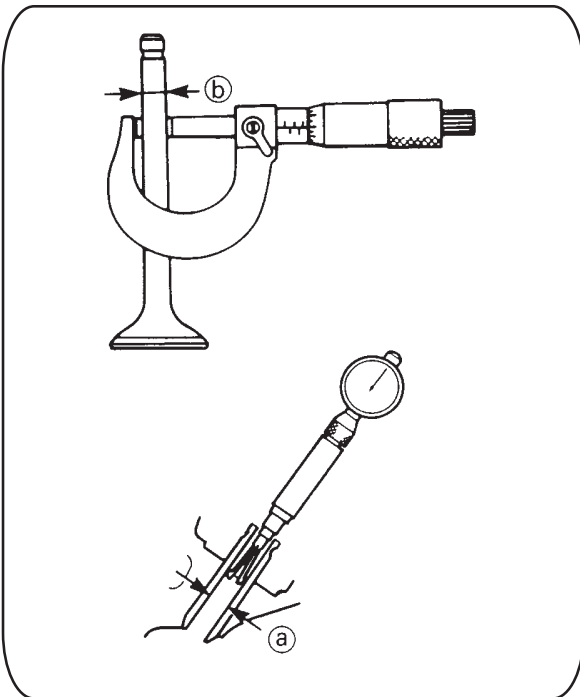

CHECKING THE VALVES AND VALVE GUIDES

The following procedure applies to all of the valves and valve guides.

1. Measure:
 - valve-stem-to-valve-guide clearance

$$\text{Valve-stem-to-valve-guide clearance} = \text{Valve guide inside diameter (a)} - \text{Valve stem diameter (b)}$$

Out of specification → Replace the valve guide.



Valve-stem-to-valve-guide clearance

Intake

0.015 ~ 0.042 mm

Limit: 0.08 mm

Exhaust

0.030 ~ 0.057 mm

Limit: 0.10 mm



2. Replace:
 - valve guide

NOTE:

To ease valve guide removal and installation, and to maintain the correct fit, heat the cylinder head to 100°C in an oven.

- a. Remove the valve guide with a valve guide remover (1).

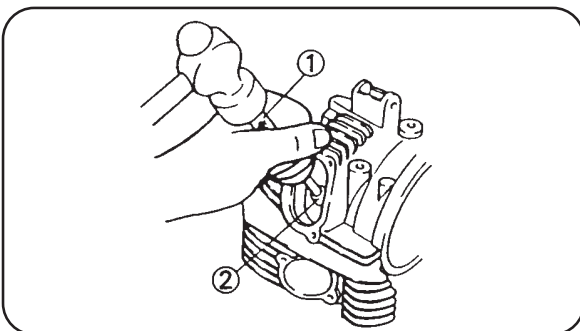

- b. Install the new valve guide with a valve guide installer (2) and valve guide remover (1).
- c. After installing the valve guide, bore the valve guide with a valve guide reamer (3) to obtain the proper valve-stem-to-valve-guide clearance.

NOTE:

After replacing the valve guide, reface the valve seat.

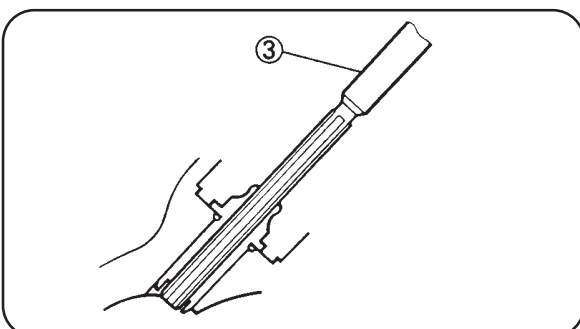

CAMSHAFT /VALVES AND VALVE SPRINGS

3. Eliminate:
 - carbon deposits
(from the valve face and valve seat)
4. Check:
 - valve face
Pitting/wear → Grind the valve face.
 - valve stem end
Mushroom shape or diameter larger than the body of the valve stem → Replace the valve.

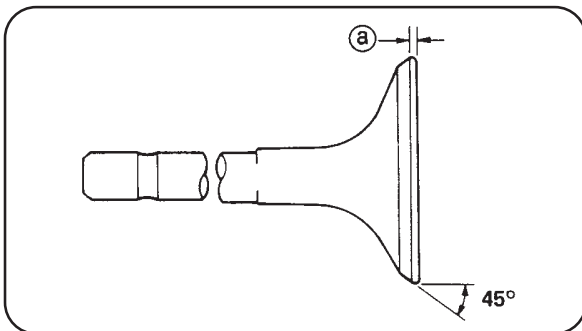

5. Measure:
 - valve margin thickness (a)
Out of specification → Replace the valve.



Valve margin thickness
0.65 ~ 0.95 mm

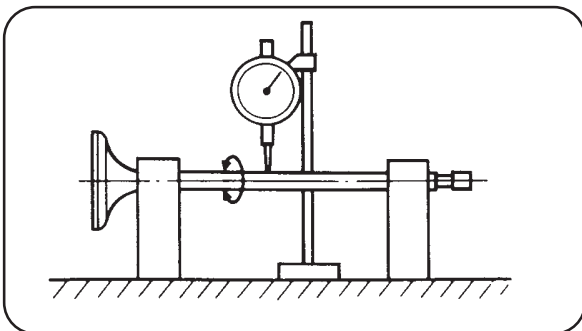

6. Measure:
 - valve stem runout
Out of specification → Replace the valve.

NOTE:

- When installing a new valve, always replace the valve guide.
- If the valve is removed or replaced, always replace the oil seal.



Valve stem runout
Limit: 0.03 mm

CHECKING THE VALVE SEATS

The following procedure applies to all of the valves and valve seats.

1. Eliminate:
 - carbon deposits
(from the valve face and valve seat)
2. Check:
 - valve seat
Pitting/wear → Replace the cylinder head.
3. Measure:
 - valve seat width (a)
Out of specification → Replace the cylinder head.

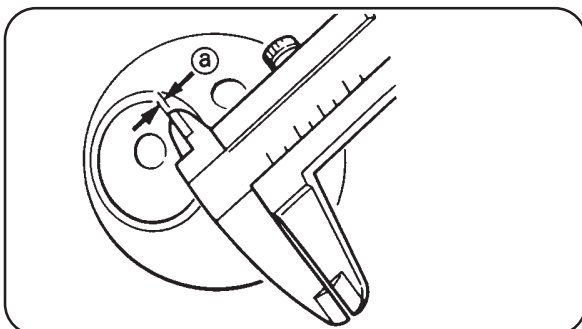

Valve seat width
Intake: 0.8 ~ 1.2mm
Limit: 1.6 mm
Exhaust: 0.8 ~ 1.2mm
Limit: 1.6 mm

CAMSHAFT / VALVES AND VALVE SPRINGS

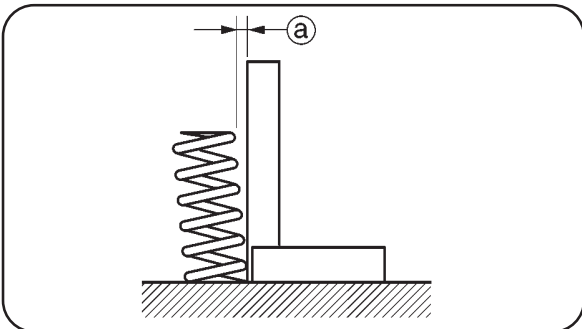
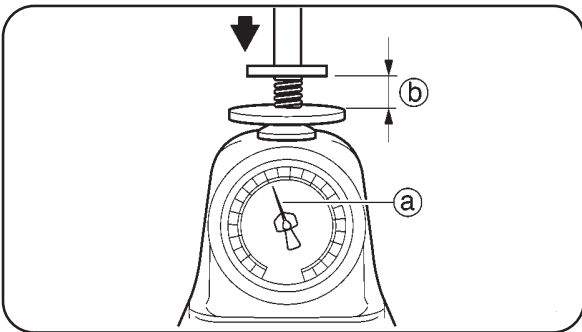
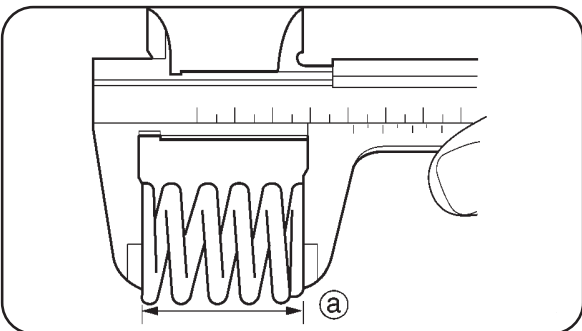
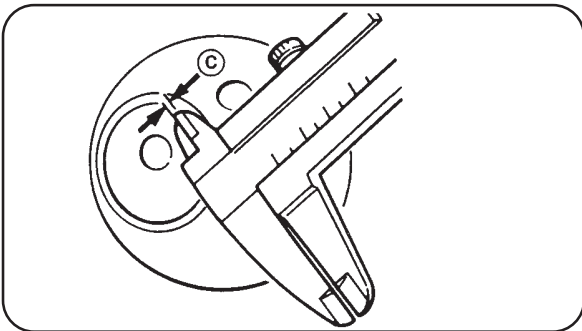
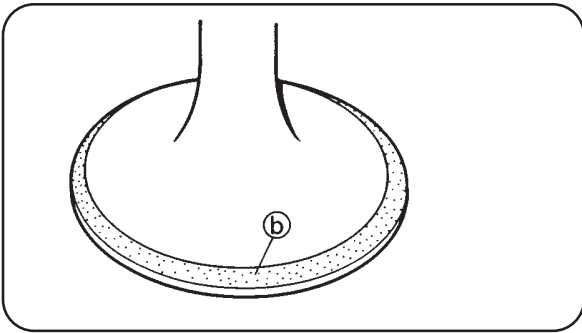

- e. Apply a fine lapping compound to the valve face and repeat the above steps.
- f. After every lapping procedure, be sure to clean off all of the lapping compound from the valve face and valve seat.
- g. Apply Mechanic's blueing dye (Dykem) (b) onto the valve face.
- h. Install the valve into the cylinder head.
- i. Press the valve through the valve guide and onto the valve seat to make a clear impression.
- j. Measure the valve seat width (c) again. If the valve seat width is out of specification, reface and lap the valve seat.



CHECKING THE VALVE SPRINGS

The following procedure applies to all of the valve springs.

1. Measure:
 - valve spring free length (a)
 - Out of specification → Replace the valve spring.



Valve spring free length (intake and exhaust)

Inner spring

33.78 mm Limit: 32.5 mm

Outer spring

35.55 mm Limit: 34.0 mm

2. Measure:
 - compressed spring force (a)
 - Out of specification → Replace the valve spring.

(b) Installed length



Compressed spring force

Intake and exhaust inner spring

52 ~ 64 Nm at 22.45 mm

Intake and exhaust outer spring

105 ~ 129 Nm at 25.45 mm

3. Measure:
 - valve spring tilt (a)
 - Out of specification → Replace the valve spring.



Spring tilt limit

Intake and exhaust inner spring

1.3°/0.8 mm

Intake and exhaust outer spring

1.35°/0.8 mm

CAMSHAFT /VALVES AND VALVE SPRINGS

INSTALLING THE VALVES

The following procedure applies to all of the valves and related components.

1. Deburr:
 - valve stem end
(with an oil stone)

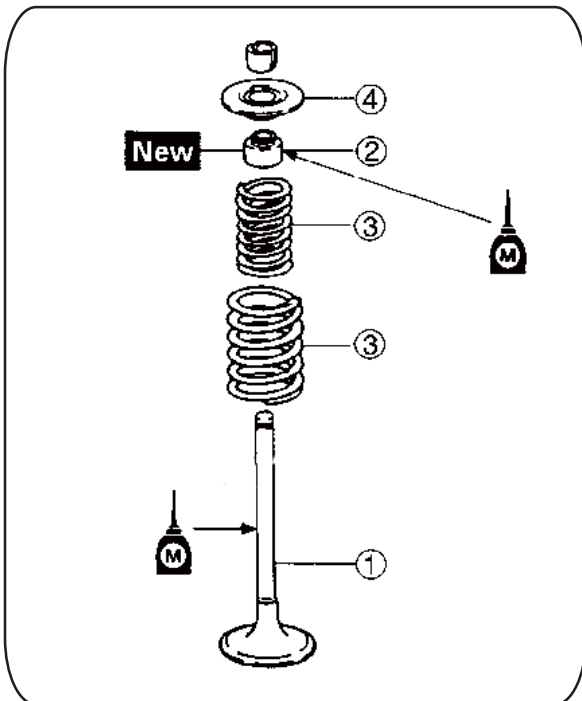

2. Lubricate:
 - valve stem
 - oil seal
(with the recommended lubricant)

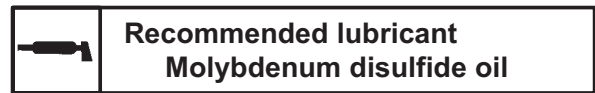

3. Install:
 - valve ①
 - oil seal ②
 - valve springs ③
 - upper spring seat ④
(into the cylinder head)

NOTE: _____
Install the valve springs with the larger pitch a facing up.

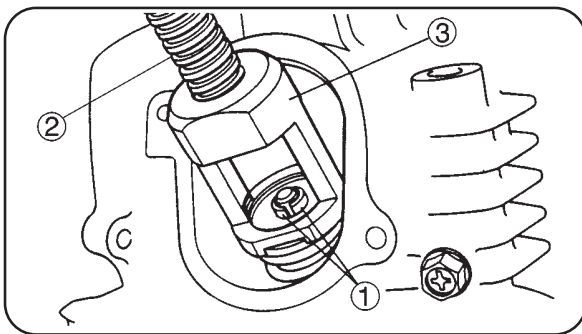

4. Install:
 - valve cotters ①

NOTE: _____
Install the valve cotters by compressing the valve springs with the valve spring compressor ② and attachment ③.

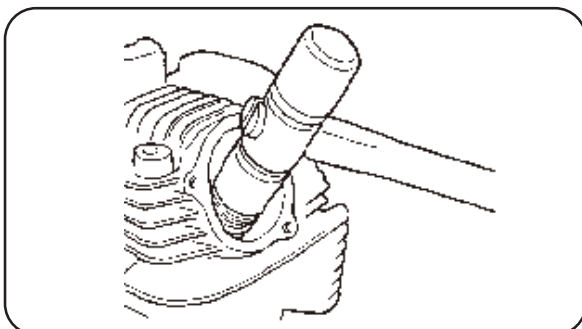

5. To secure the valve cotters onto the valve stem, lightly tap the valve tip with a soft-face hammer.

CAUTION: _____

Hitting the valve tip with excessive force could damage the valve.

CYLINDER AND PISTON

CYLINDER AND PISTON

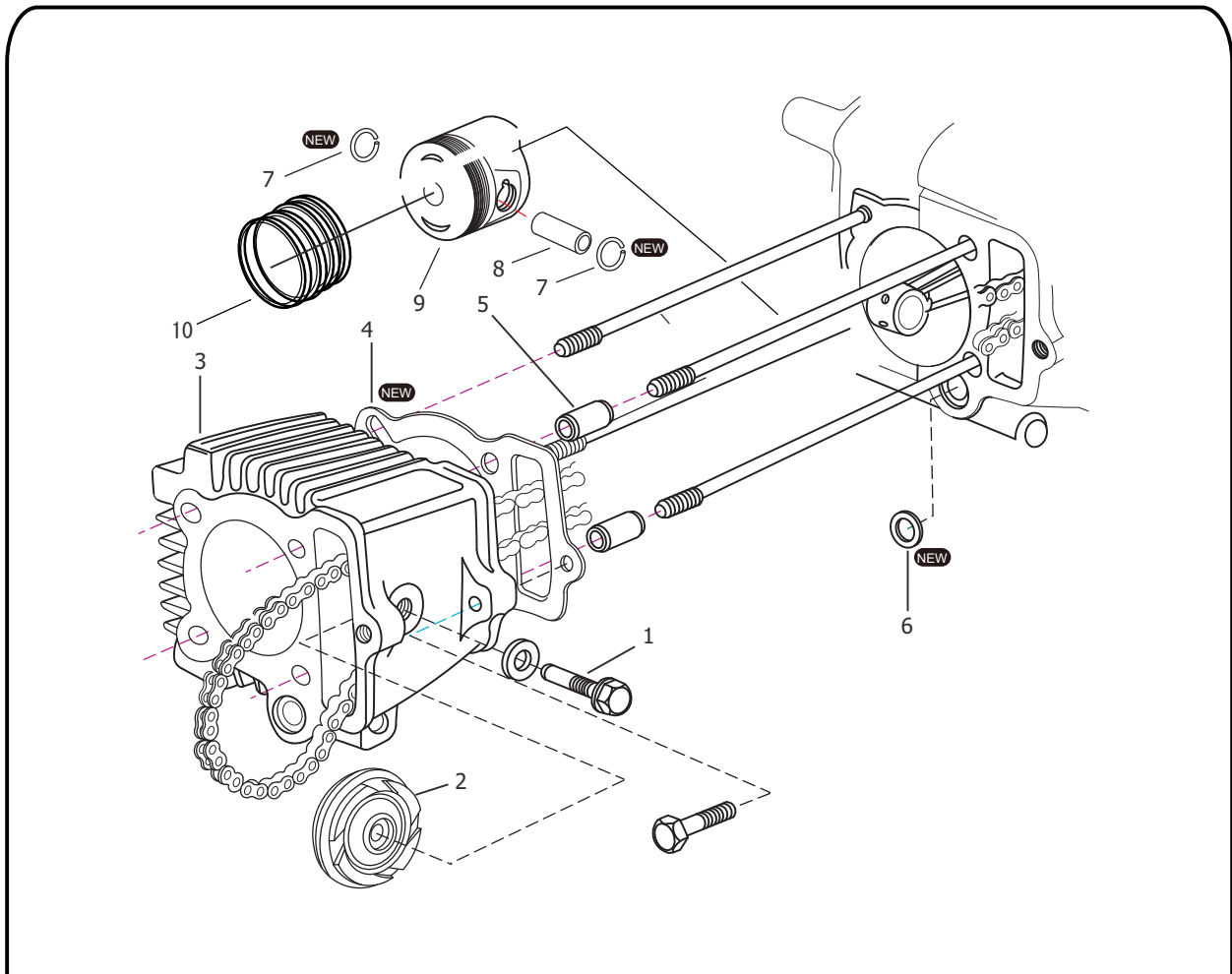

Order	Job / Part name	Q'ty	Remarks
			Remove the parts in the order listed.
1	PIN SHAFT, GUIDEROLLER	1	
2	CAM CHAIN GUIDE ROLLER	1	
3	CYLINDER BLOCK	1	
4	GASKET, CYLINDER BLOCK	1	
5	DOWEL PIN	1	
6	RECTANGLE RING	1	
7	CIRCLIP, PISTON PIN	2	
8	PISTON PIN	1	
9	PISTON	1	
10	PISTON RING	1	

For installation, reverse the removal procedure.

CYLINDER AND PISTON

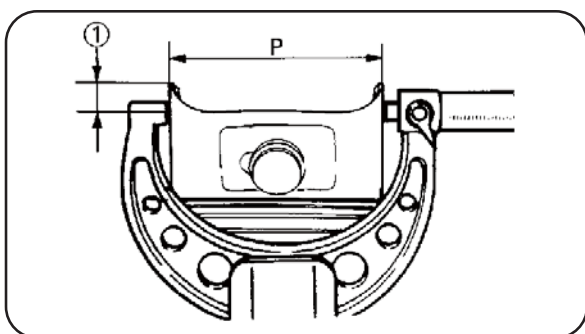

b. If out of specification, rebore or replace the cylinder, and replace the piston and piston rings as a set.

c. Measure piston skirt diameter "P" with the micrometer.

① 7.0 mm from the bottom edge of the piston.

	Piston size "P"
Standard	53.965 ~ 53.975 mm

d. If out of specification, replace the piston and piston rings as a set.

e. Calculate the piston-to-cylinder clearance with the following formula.

$$\text{Piston-to-cylinder clearance} = \text{Cylinder bore "C"} - \text{Piston skirt diameter "P"}$$



Piston-to-cylinder clearance
0.025 ~ 0.05 mm

f. If out of specification, rebore or replace the cylinder, and replace the piston and piston rings as a set.

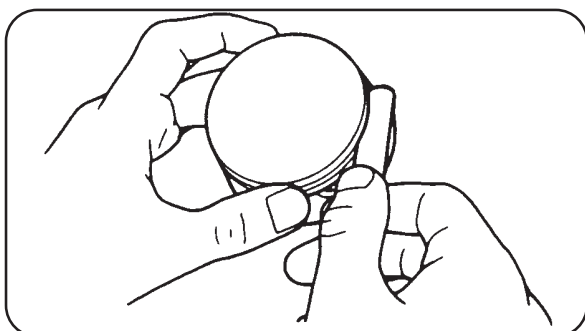

CHECKING THE PISTON RINGS

1. Measure:

- piston ring side clearance

Out of specification → Replace the piston and piston rings as a set.

NOTE: _____

Before measuring the piston ring side clearance, eliminate any carbon deposits from the piston ring grooves and piston rings.



Piston ring side clearance
Top ring
 0.04 ~ 0.08 mm
 <Limit>: 0.12mm
2nd ring
 0.04 ~ 0.08 mm
 <Limit>: 0.12mm

CYLINDER AND PISTON

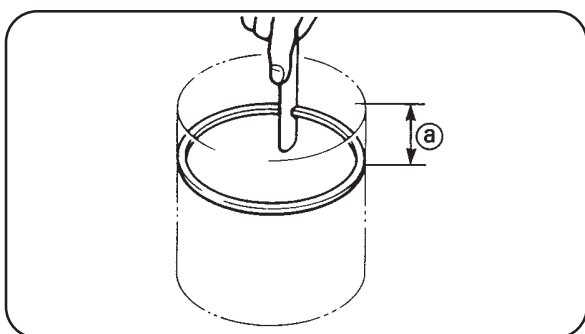

2. Install:
 - piston ring
(into the cylinder)

NOTE: _____
Level the piston ring in the cylinder with the piston crown as shown.

① 5.0 mm

3. Measure:
 - piston ring end gap
Out of specification → Replace the piston ring.

NOTE: _____
The oil ring expander spacer's end gap cannot be measured. If the oil ring rail's gap is excessive, replace all three piston rings.



Piston ring end gap

Top ring

0.10 ~ 0.25 mm

<Limit>: 0.60 mm

2nd ring

0.15 ~ 0.30 mm

<Limit>: 0.60 mm

Oil ring

0.2 ~ 0.5 mm

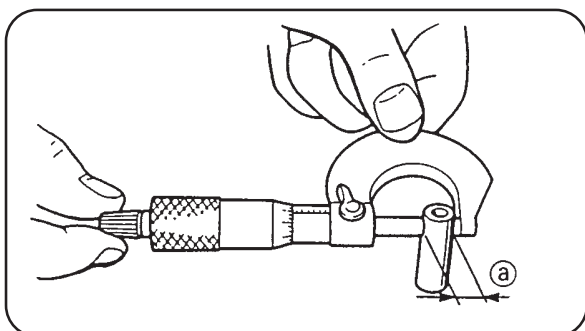

CHECKING THE PISTON PIN

1. Check:
 - piston pin
Blue discoloration/grooves → Replace the piston pin and then check the lubrication system.
2. Measure:
 - piston pin outside diameter ①
Out of specification → Replace the piston pin.



Piston pin outside diameter

13.994 ~ 14.000 mm

3. Calculate:
 - piston-pin-to-piston clearance
Out of specification → Replace the piston pin and piston as a set.

CYLINDER AND PISTON

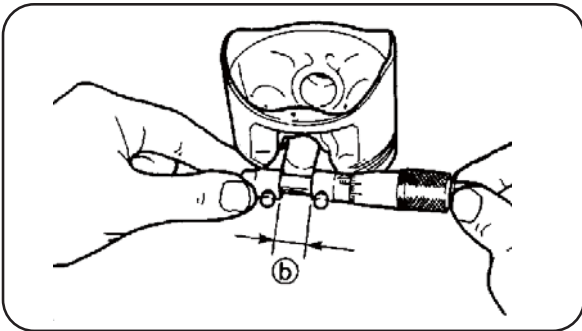

Piston-pin-to-piston clearance =
Piston pin bore size (b) –
Piston pin outside diameter (a)



Piston-pin-to-piston clearance
0.002 ~ 0.019 mm

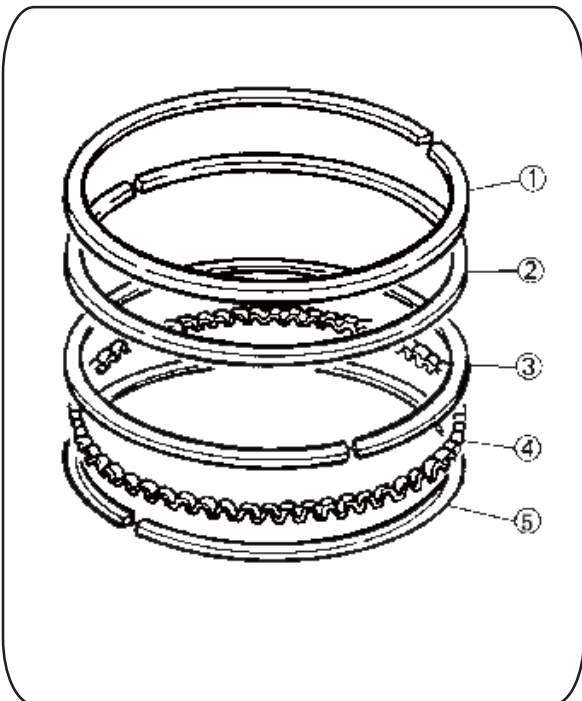

INSTALLING THE PISTON AND CYLINDER

1. Install:

- top ring ①
- 2nd ring ②
- upper oil ring rail ③
- oil ring expander ④
- lower oil ring rail ⑤

NOTE:

Be sure to install the piston rings so that the manufacturer's marks or numbers face up.

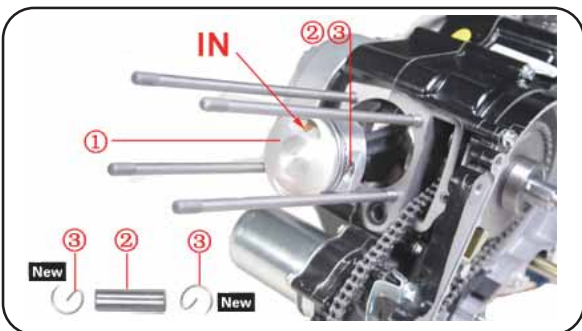

2. Install:

- piston ①
- piston pin ②
- piston pin clip ③ **New**

NOTE:

- Apply engine oil onto the piston pin.
- Make sure that the mark "IN" on the piston points towards the intake side of the cylinder.
- Before installing the piston pin clip, cover the crankcase opening with a clean rag to prevent the clip from falling into the crankcase.

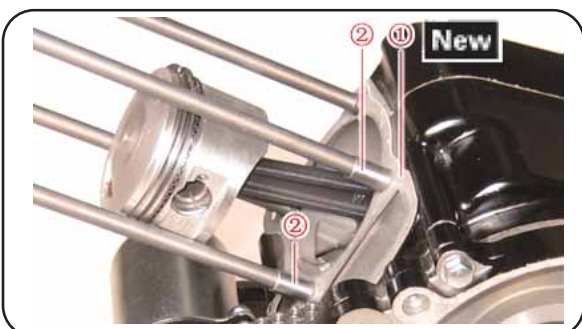

3. Install:

- gasket ① **New**
- dowel pins ②

4. Lubricate:

- piston
- piston rings
- cylinder
(with the recommended lubricant)



Recommended lubricant
Engine oil

CYLINDER AND PISTON

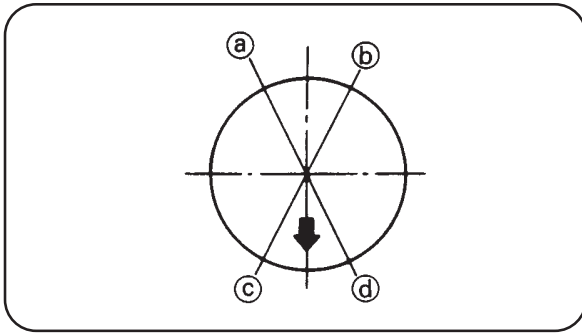

5. Offset:
- piston ring end gaps
- (a) Top ring
(b) Lower oil ring rail
(c) Upper oil ring rail
(d) 2nd ring



6. Install:
- cylinder ①

NOTE: _____

- While compressing the piston rings with one hand, install the cylinder with the other hand.
 - Pass the timing chain and timing chain guide (exhaust side) through the timing chain cavity.
- _____

CLUTCH

CLUTCH

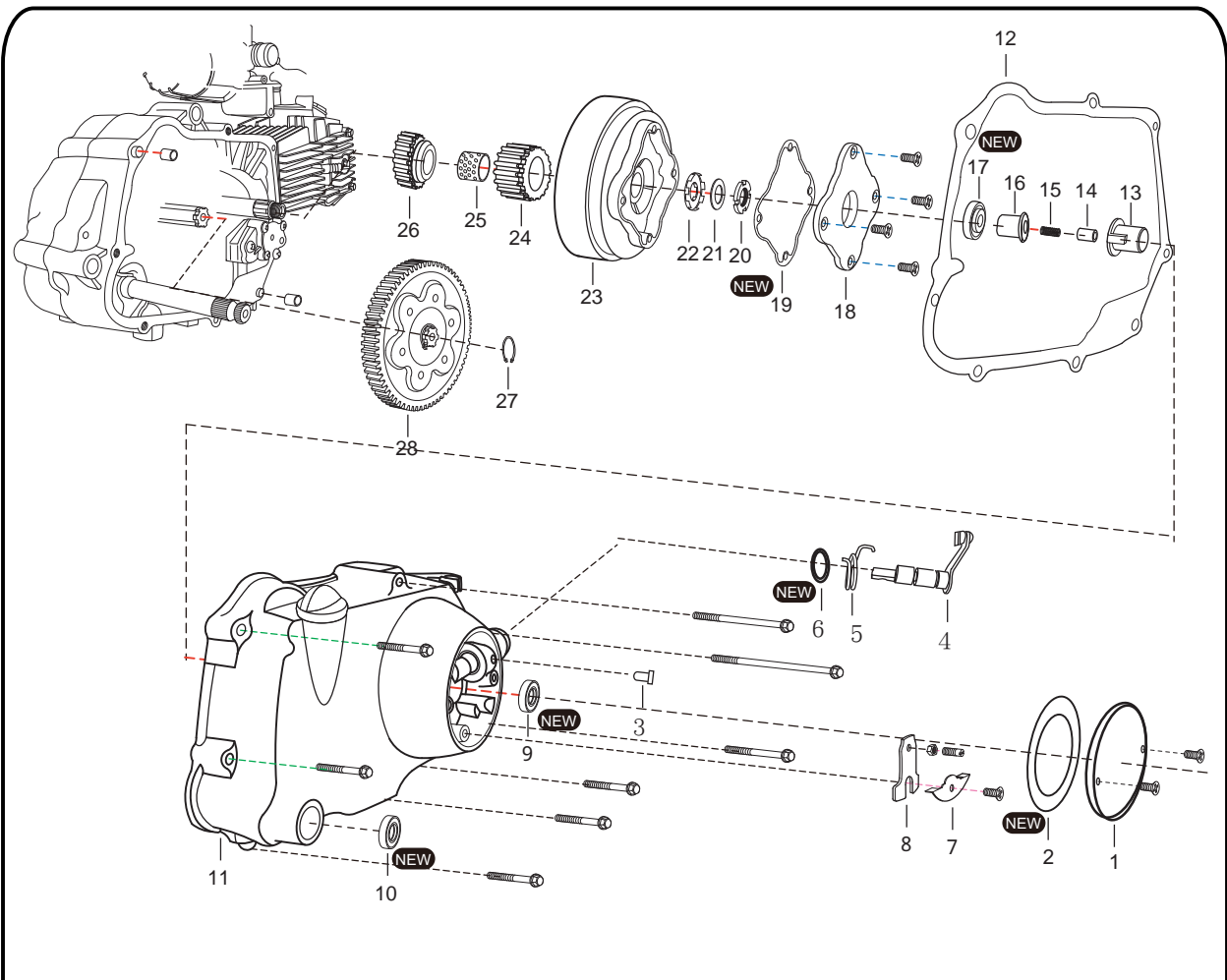

Order	Job / Part name	Q'ty	Remarks
1	DECORATE COVER,R CRANK CASE COVER	1	Remove the parts in the order listed.
2	GASKET,DECORATE COVER	1	
3	CLUTCHLEVER PIN	1	
4	CLUTCHLEVER ASSY	1	
5	CLUTCH CAM SHAFT SPRING	1	
6	O-RING	1	
7	CLUTCH SHIFTING PLATE	1	
8	CLUTCH PRESSURE PLATE	1	
9	OIL SEAL	1	
10	OIL SEAL	1	
11	R ,CRANK CASE COVER	1	
12	GASKET,R ,CRANK CASE COVER	1	
13	CLUTCH PUSH ROD	1	
14	OIL TUBE	1	
15	OIL THIMBLE SPRING	1	
16	OIL THIMBLE	1	
17	BEARING	1	
18	CLUTCH END COVER	1	

CLUTCH

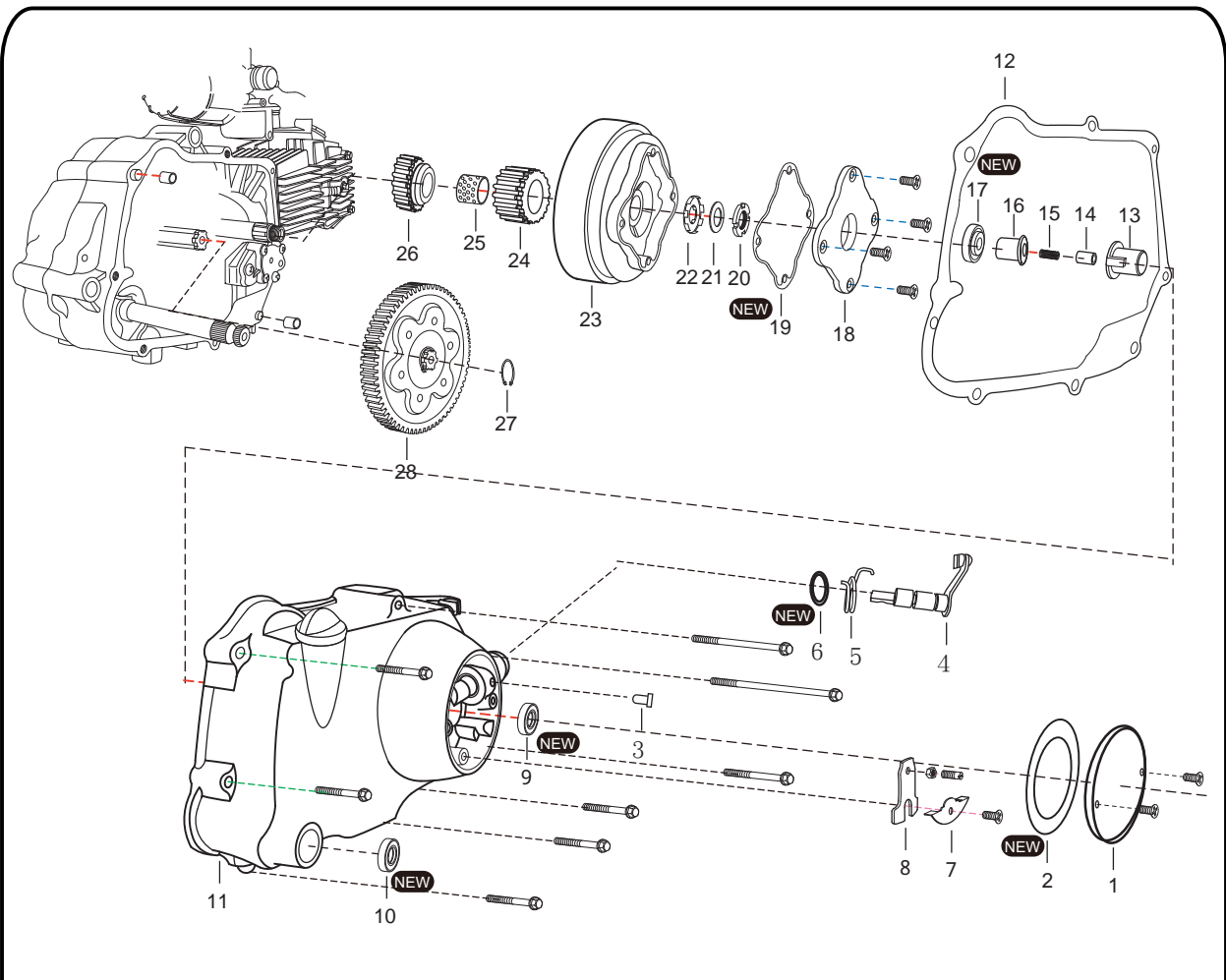

Order	Job / Part name	Q'ty	Remarks
			Remove the parts in the order listed.
19	GASKET,END COVER	1	
20	NUT	1	
21	WASHER	1	
22	THURST WASHER	1	
23	CLUTCH ASSY	1	
24	DRIVER GEAR	1	
25	SLEEVE	1	
26	BUSH	1	
27	CIRCLIP	1	
28	DRIVEN GEAR CAM	1	
			For installation, reverse the removal procedure.

CLUTCH

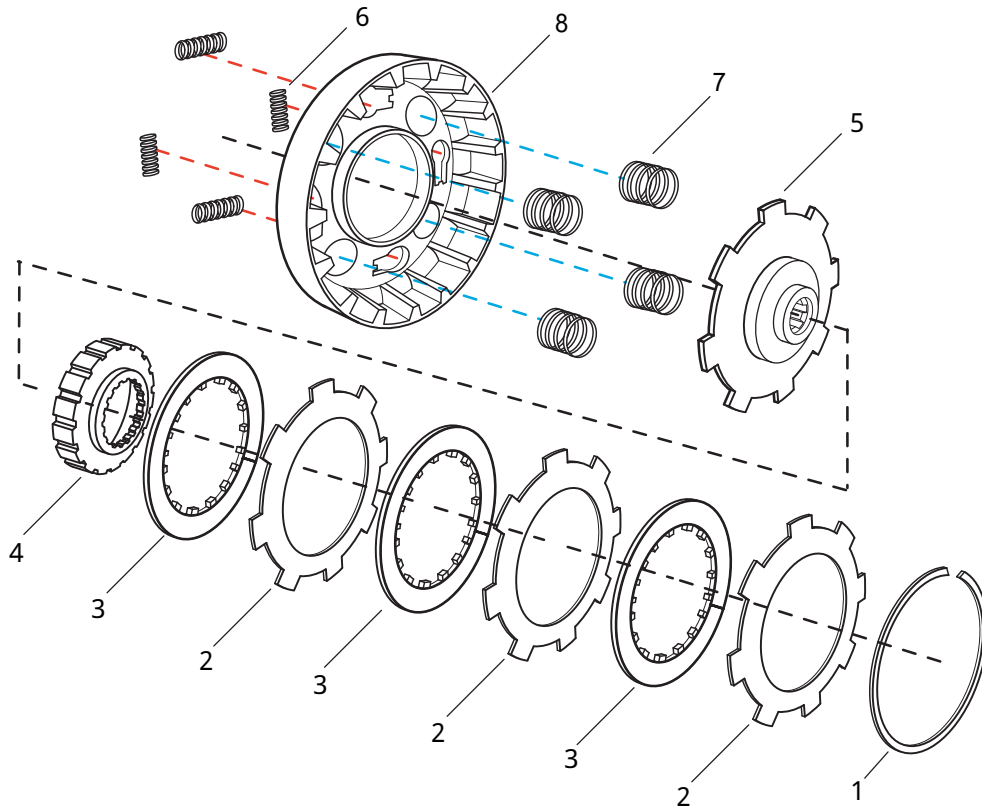

Order	Job / Part name	Q'ty	Remarks
			Remove the parts in the order listed.
1	CIRCLIP	1	
2	PLATE	3	
3	CLUTCH DRIVE FRICTION PLATE	3	
4	CLUTCH CENTER SLEEVE	1	
5	DRIVE PLATE	1	
6	CLUTCH CUSHION SPRING	1	
7	CLUTCH SPRING	1	
8	CLUTCH OUTER CASE	1	
			For installation, reverse the removal procedure.

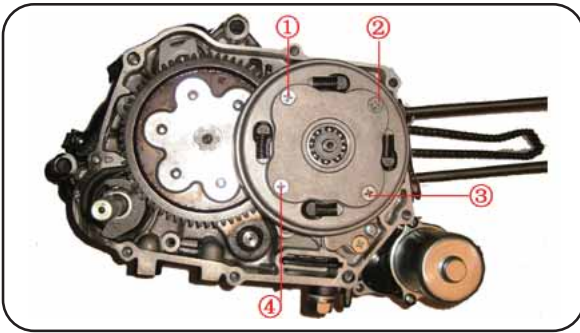

REMOVING THE CLUTCH

1. Remove:
Screw ① - ④.

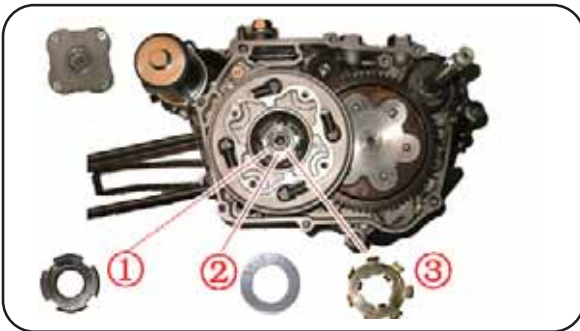

2. Straighten the lock washer tab
3. Remove:
 - clutch boss nut
 - washer

NOTE:

While holding the clutch boss with the universal clutch holder, loosen the clutch boss nut.

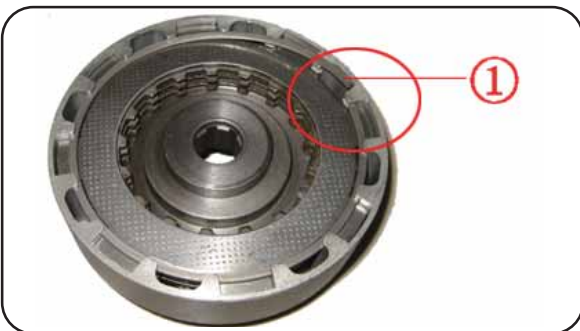

4. Remove:
 - snap spring

CHECKING THE FRICTION PLATES

The following procedure applies to all of the friction plates.

1. Check:
 - friction plate

Damage/wear → Replace the friction plates as a set.
2. Measure:
 - friction plate thickness

Out of specification → Replace the friction plates as a set.

NOTE:

Measure the friction plate at four places.

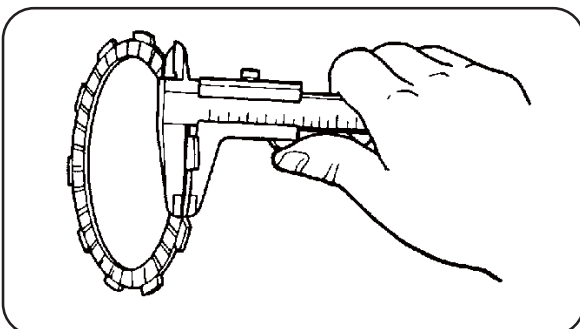

	Friction plate thickness
	2.85 ~ 2.95 mm
	<Limit>: 2.7 mm

CHECKING THE CLUTCH PLATES

The following procedure applies to all of the clutch plates.

1. Check:
 - clutch plate

Damage → Replace the clutch plates as a set.

CLUTCH

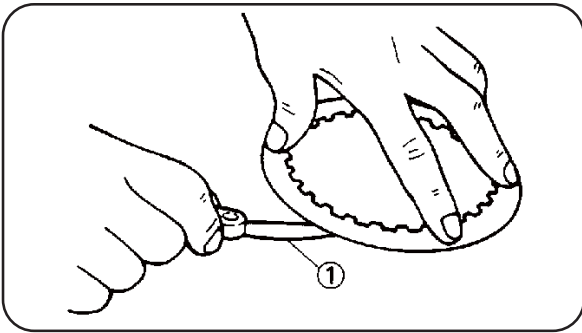

2. Measure:

- clutch plate warpage
(with a surface plate and thickness gauge
①)
Out of specification → Replace the clutch plates as a set.

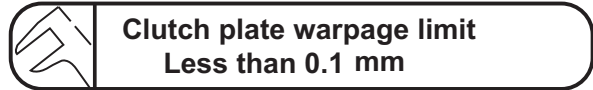

CHECKING THE CLUTCH SPRINGS

The following procedure applies to all of the clutch springs.

1. Check:

- clutch spring
Damage → Replace the clutch springs as a set.

2. Measure:

- clutch spring free length
Out of specification → Replace the clutch springs as a set.

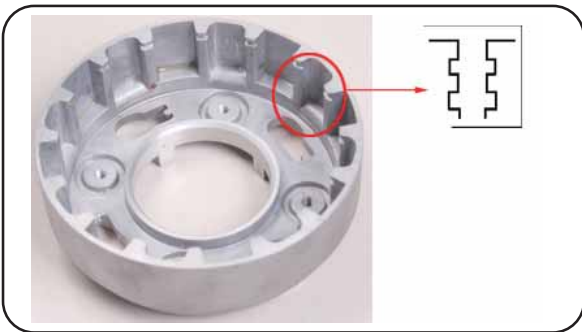
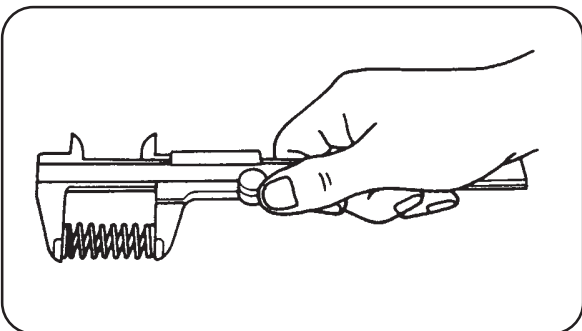

CHECKING THE CLUTCH OUTER CASE

1. Check:

- clutch outer case dogs
Damage/pitting/wear → Deburr the clutch outer case dogs or replace it.

NOTE: _____

Pitting on the clutch housing dogs will cause erratic clutch operation.

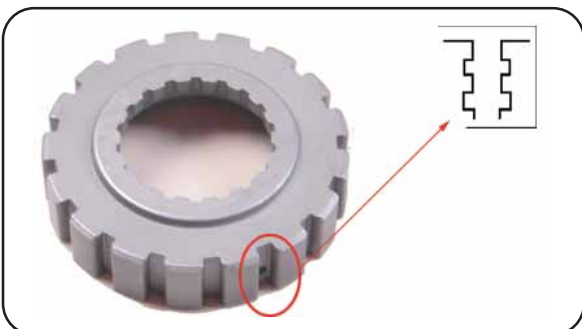

CHECKING THE CLUTCH CENTER SLEEVE

1. Check:

- clutch center sleeve splines
Damage/pitting/wear → Replace the clutch center sleeve.

NOTE: _____

Pitting on the clutch sleeve splines will cause erratic clutch operation.

CLUTCH



INSTALLING THE CLUTCH ASSY

1. Install:

- put the clutch spring into the clutch outer case.



- put the drive plate into the clutch outer case.

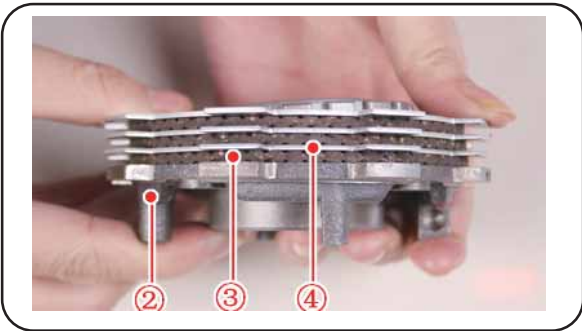

2. Lubricate:

- friction plates
- upper plates

(with the recommended lubricant)



3. Install:

- friction plates
- upper plates

NOTE: _____

First, install a friction plate and then alternate between a upper plate and a friction plate.

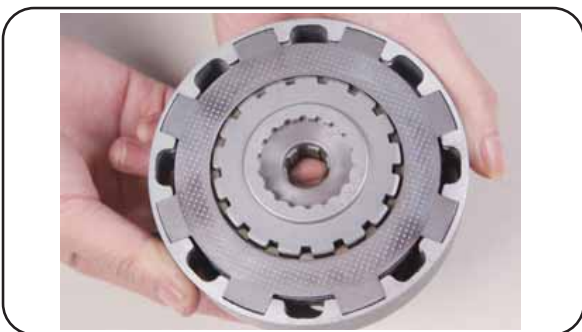

4. Install:

- pressure plate and install clutch circlip

CLUTCH

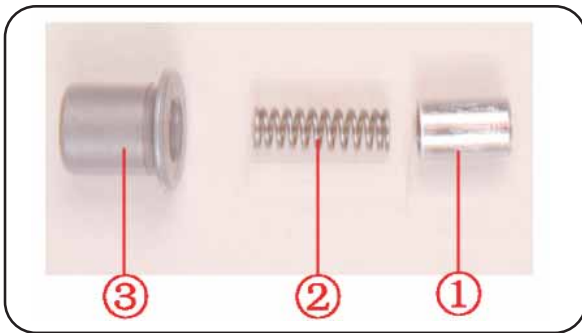

CHECKING THE CLUTCH PUSH RODS

1. Check:

- oil tube ①
- oil thimble spring ②
- oil thimble ③

Cracks/damage/wear → Replace the defective part(-s).

2. Measure:

- oil thimble spring free length
- Out of specification → Replace the oil thimble spring.

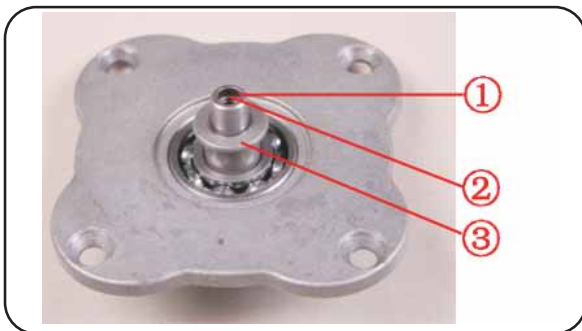
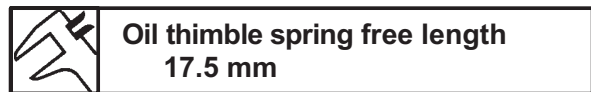

INSTALLING THE CLUTCH

1. Install:

- clutch assy ①

NOTE: _____

Make sure that the teeth on the lock washer are correctly aligned with the grooves on the clutch boss.

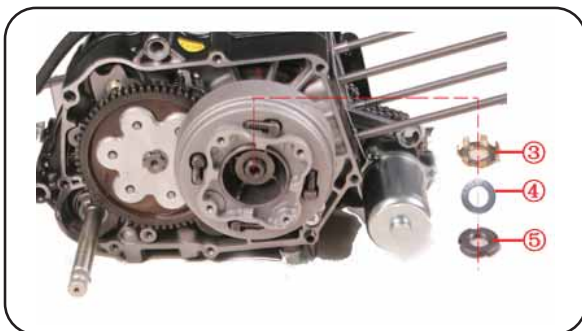

- thrust washer ,make sure the “OUT SIDE” mark on the washer is upturned.

2. Tighten:

- clutch boss nut ⑤

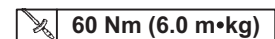

NOTE: _____

While holding the clutch boss with the universal clutch holder , tighten the clutch boss nut.



3. Bend the lock washer tab along a flat side of the nut.

CLUTCH

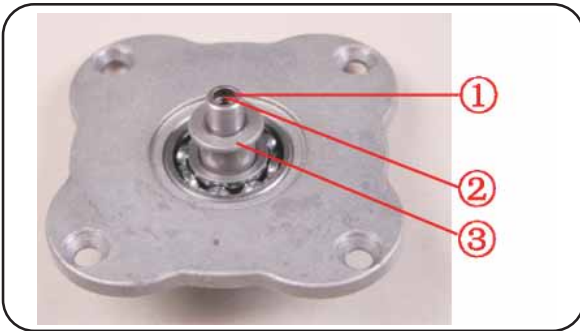

4. Install:
- oil tube ①
 - oil thimble spring ②
 - oil thimble ③

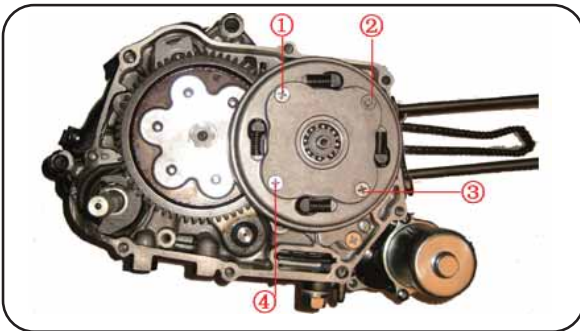

- screw ① - ④

 **6 Nm (0.6 m • kg)**

5. Check
- clutch assy

NOTE: _____
Make sure that the teeth on the lock washer are correctly aligned with the grooves on the clutch boss.

OIL PUMP

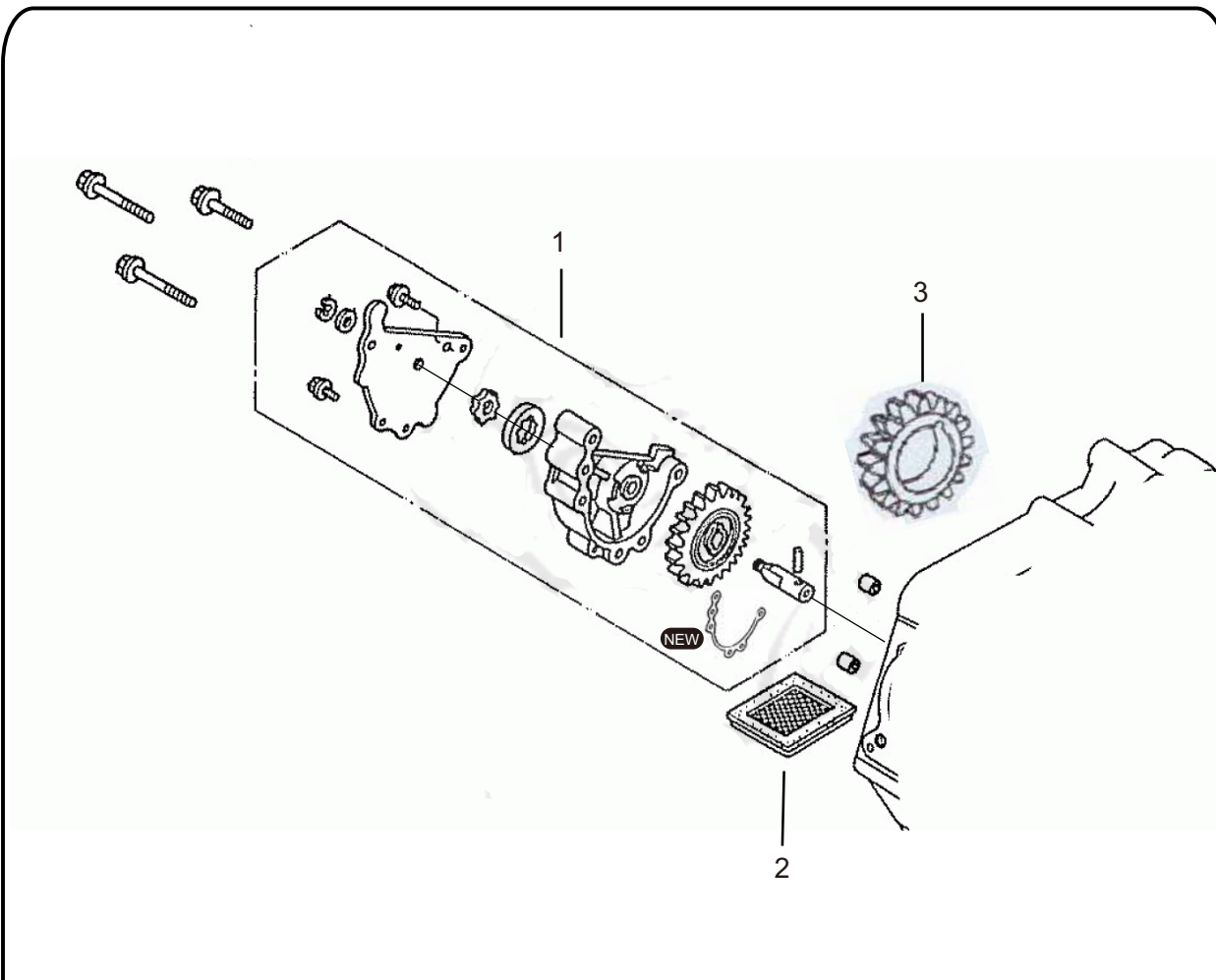

Order	Job / Part name	Q'ty	Remarks
1	OIL PUMP	1	Remove the parts in the order listed.
2	OIL FILTER SCREEN	1	
3	GEAR	1	
			For installation, reverse the removal procedure.

OIL PUMP

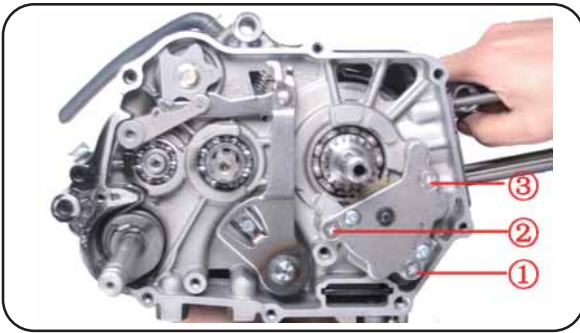

REMOVING THE OIL PUMP

1. Remove:

- Screw - .



2. Remove:

- gasket of oil pump
- gear of oil pump

NOTE:

Remove the gasket of oil pump and check the state. Replace if worn or if reuse if questionable.

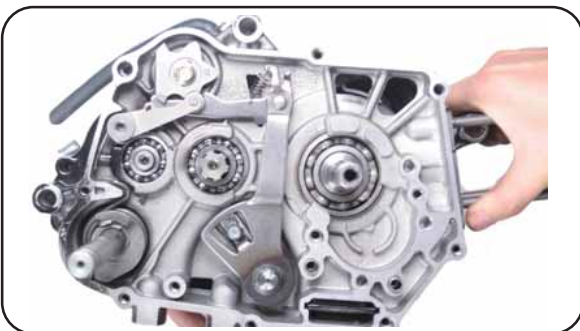

3. Check:

- Remove the oil pump and inspect oil way for smoothness. clean oil way as necessary.
- Check whether the gear is worn.



MAGNETO AND STARTER GEAR

MAGNETO AND STARTER GEAR

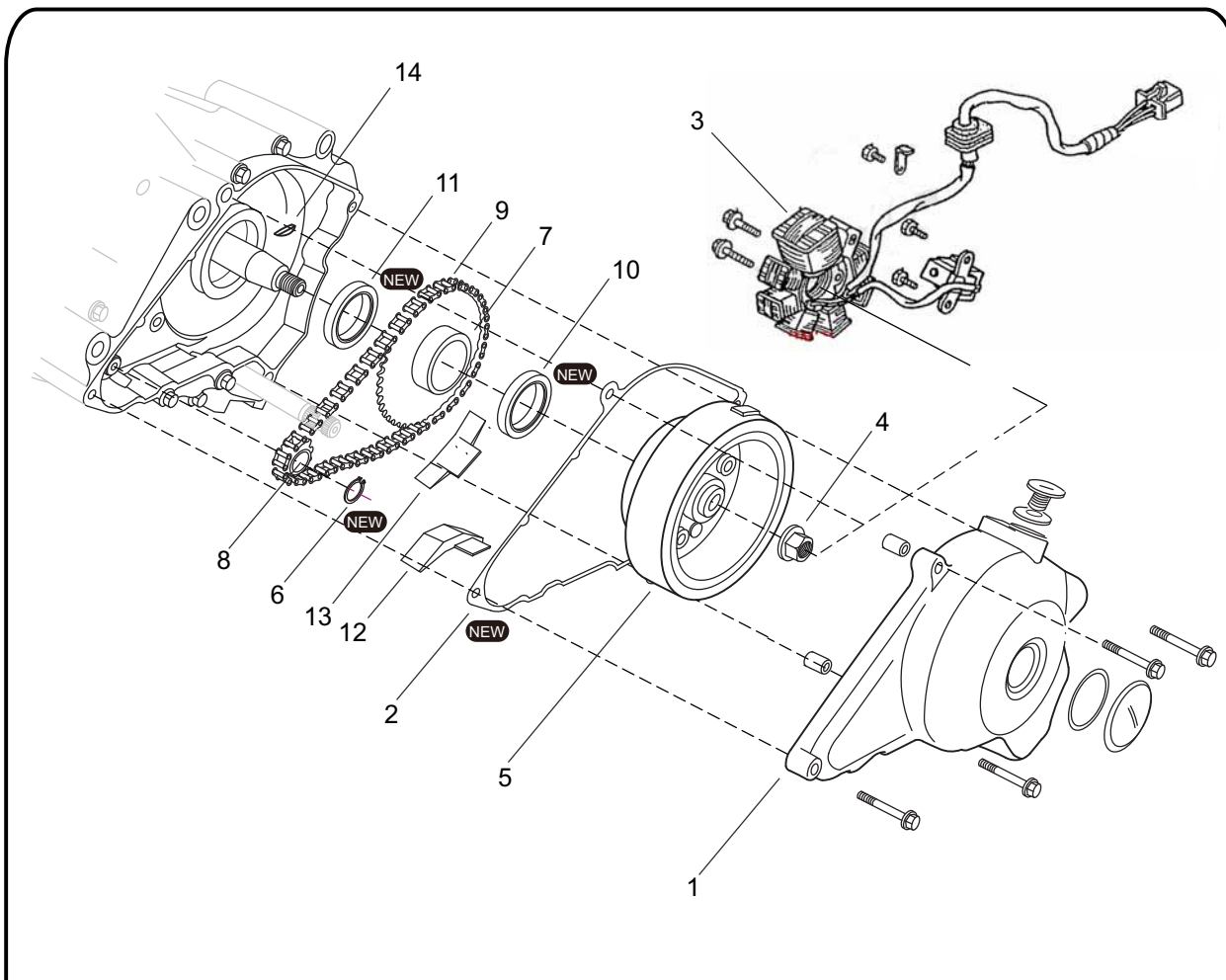

Order	Job / Part name	Q'ty	Remarks
			Remove the parts in the order listed.
1	FRONT COVER, LEFT CRANKCASE	1	
2	GASKET, LEFT CRANKCASE	1	
3	STATOR , MAGNETO	1	
4	NUT	1	
5	COTOR , MAGNETO	1	
6	CIRCLIP 10	1	
7	DRIVEN SPROCKET, STARTING MOTOR	1	
8	DRIVE SPROCKET, STARTING MOTOR	1	
9	STARTING MOTOR DRIVE CHAIN	1	
10	OIL SEAL 19×30×5	1	
11	OIL SEAL	1	
12	CHAIN PROTECT PLATE	1	
13	CHAIN GUIDE PLATE	1	
14	WOODRUFF KEY	1	

For installation, reverse the removal procedure.

MAGNETO AND STARTER GEAR

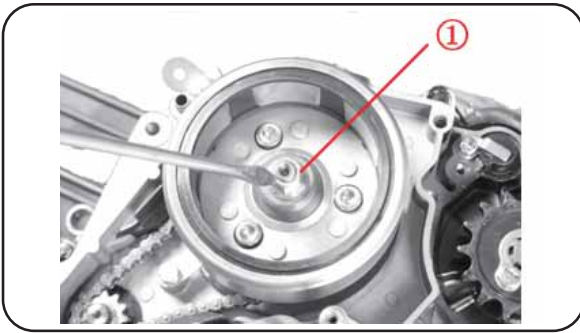

REMOVING THE GENERATOR ROTOR

1. Remove:
 - bolt ① (magneto)

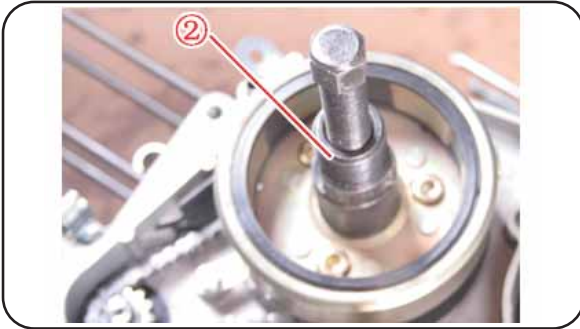

NOTE:

- Loosen the bolt (generator rotor) ① while holding the rotor with a sheave holder ②.
- Do not allow the sheave holder to touch the projection on the rotor.

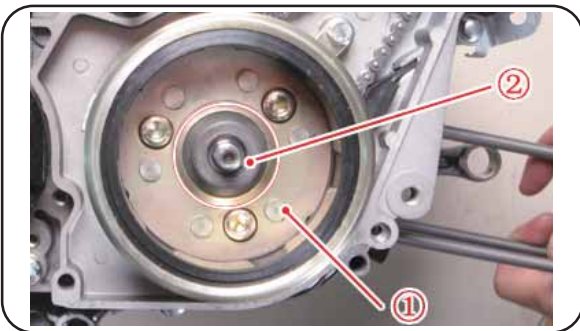

2. Remove:
 - generator rotor ①
 - woodruff key

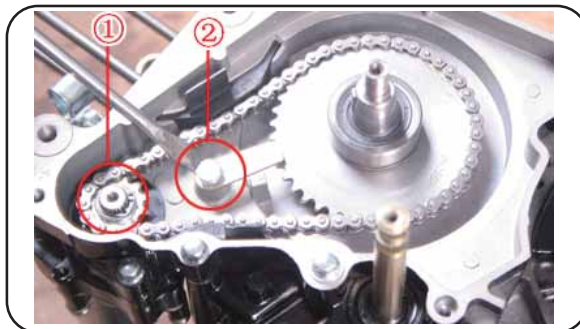

3. Remove:
 - circlip ①
 - bolt

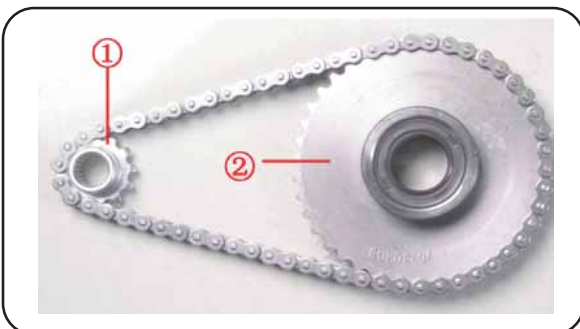

CHECKING THE STARTER CLUTCH

1. Check:
 - starter clutch drive gear ①
 - starter clutch gear ②

Burrs/chips/roughness/wear → Replace the defective part(-s).

MAGNETO AND STARTER GEAR

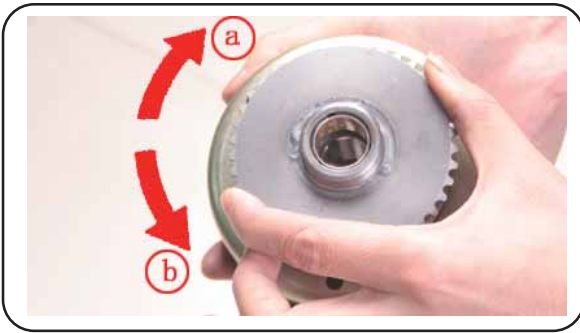

2. Check:
 - starter clutch operation



- a. Hold the starter clutch.
- b. When turning the starter clutch gear clockwise (a), the starter clutch and the starter clutch gear should engage. If the starter clutch gear and starter clutch do not engage, the starter clutch is faulty and must be replaced.
- c. When turning the starter clutch gear counter-clockwise (b), it should turn freely. If the starter clutch gear does not turn freely, the starter clutch is faulty and must be replaced.

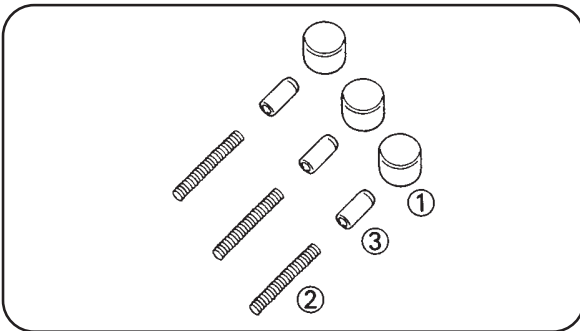

3. Inspect:
 - dowel pins ①
 - compression springs ②
 - spring caps ③
 Wear/Damage → Replace.



4. Inspect:
 - starter wheel gear (contacting surface)
 Pitting/Wear/Damage → Replace.



INSTALLING THE STARTER CLUTCH

1. Install:
 - starter clutch assembly ①

30 Nm (3.0 m•kg)

2. Unloosen the starter clutch assembly by using the center punch.
3. Install:
 - compression springs ①
 - spring caps ②
 - dowel pins ③

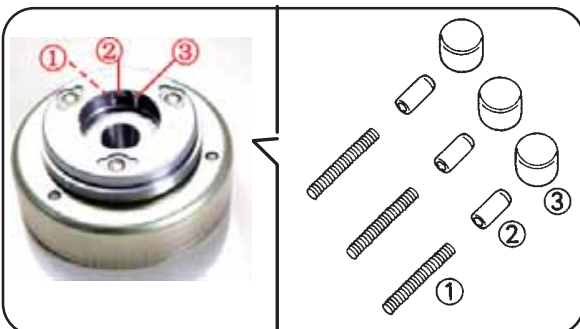

MAGNETO AND STARTER GEAR

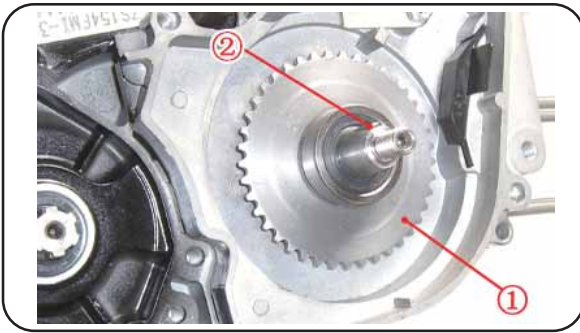

INSTALLING THE GENERATOR ROTOR

1. Install:

- starter wheel gear ①
- woodruff key ②

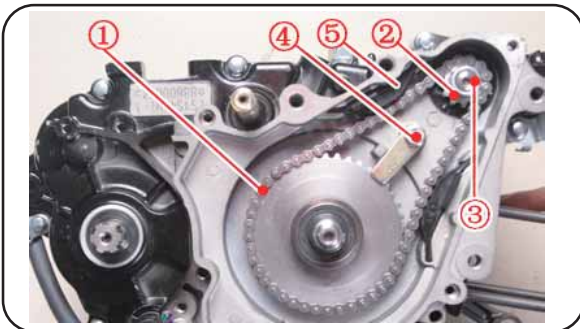

2. Install:

- starting motor drive chain
- drive gear
- circlip
- bolt
- chain protect plate

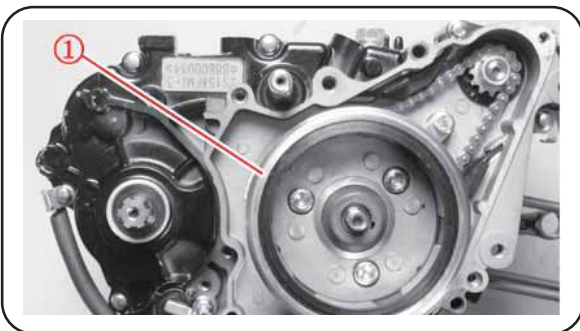

3. Install:

- generator rotor ①

NOTE:

- Clean the tapered portion of the crankshaft and the rotor hub.
- When installing the rotor, make sure the woodruff key is properly seated in the key way of the crankshaft and turning the starter wheel gear clockwise.

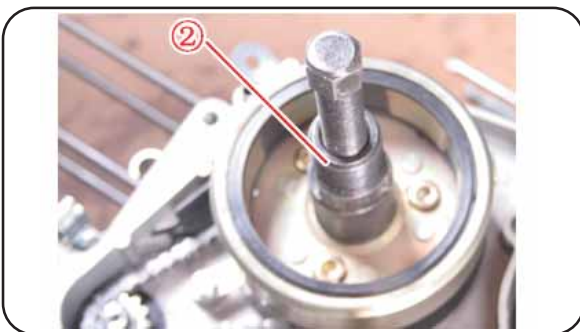

4. Tighten:

- generator rotor ②

 50 Nm (5.0 m•kg)

NOTE:

Tighten the bolt while holding the generator rotor with the sheave holder .

CAM CHAIN-TENSIONOR

CAM CHAIN-TENSIONOR

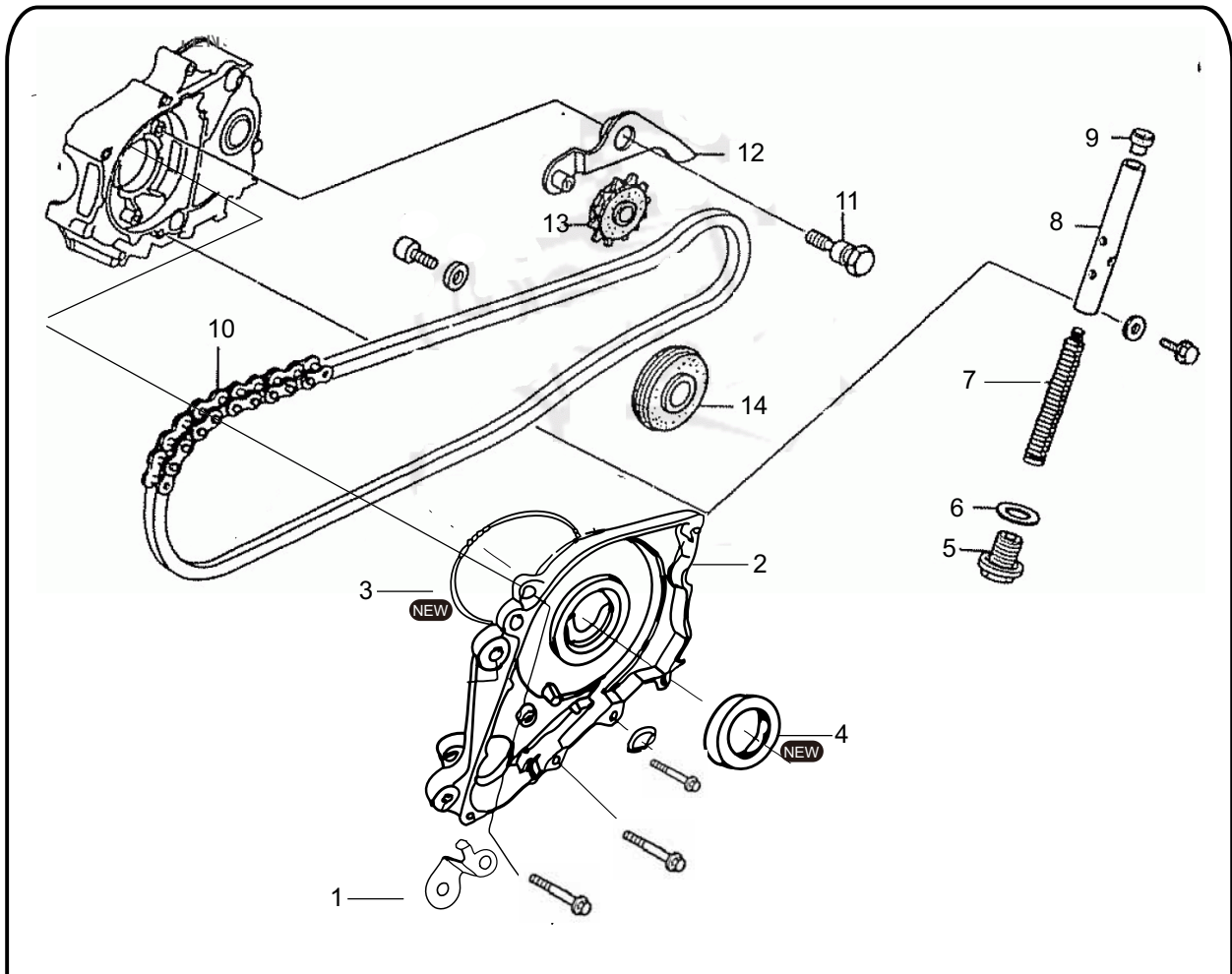

Order	Job / Part name	Q'ty	Remarks
			Remove the parts in the order listed.
1	CLIP, VOLTAGE WIRE	1	
2	LOWER PAN, OIL INSULATING	1	
3	O-RING	1	
4	OIL SEAL	1	
5	BOLT M14×1.5	1	
6	WASHER	1	
7	SPRING, CHAIN TENSIONER PUSH ROD	1	
8	CHAIN TENSIONER PUSH ROD	1	
9	TIGHTENING ROD HEAD	1	
10	TIMING CHAIN	1	
11	TIGHTENING ARM SHAFT	1	
12	TIGHTENING ARM	1	
13	TIGHTENING IDLER WHEEL SET	1	
14	OIL PUMP DRIVE SPROCKET	1	
			For installation, reverse the removal procedure.

CAM CHAIN-TENSIONOR

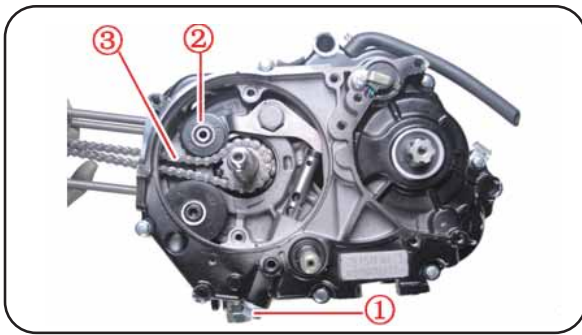

CAM CHAIN TENSIONOR

1. Remove:

- bolt of cam chain tensor
- roller of cam chain tensor ②
- cam chain ③

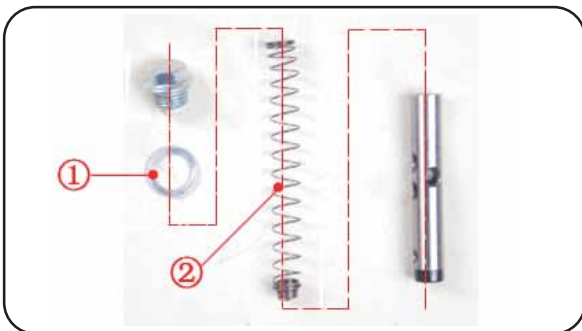

2. Check:

- aluminium washer
Pitting/Wear/Damage → Replace.
- spring of chain tensor push rod ②.
Pitting/Wear/Damage → Replace.



INSTALLING THE CAM CHAIN TENSIONOR

1. Install:

- bolt of cam chain tensor ①

 20 Nm (2.0 m • kg)

CRANKSHAFT AND GEARSHIFT ARM

CRANKSHAFT AND GEARSHIFT ARM

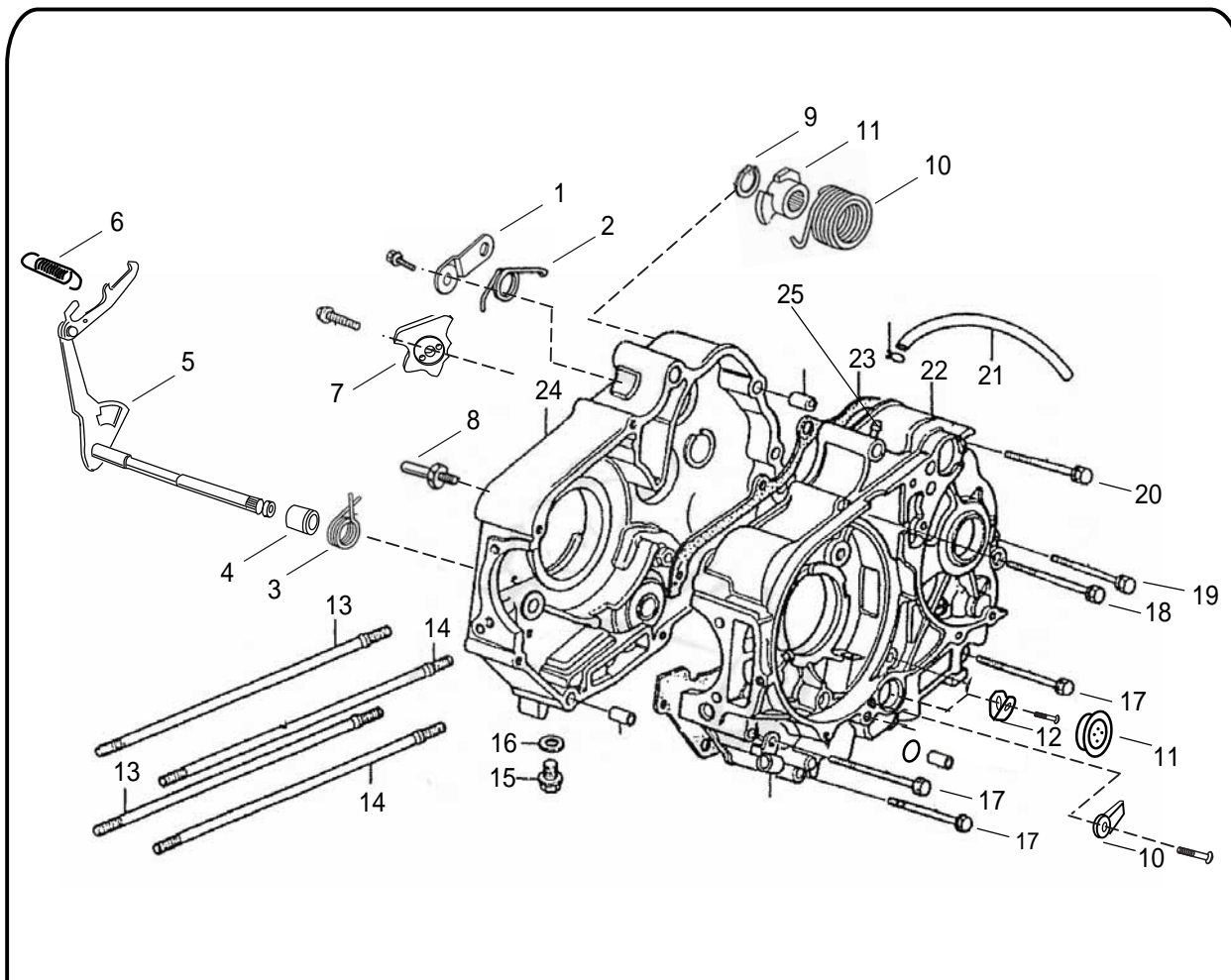

Order	Job / Part name	Q'ty	Remarks
			Remove the parts in the order listed.
1	BOLT, LOCATING PLATE LOCATING PLATE GROUP	1	
2	RETURN SPRING, LOCATING PLATE	1	
3	RETURN SPRING, GEARSHIFT LEVER	1	
4	BUSH	1	
5	GEARSHIFT LEVER BODY ASSY	1	
6	TENSION SPRING, GEARSHIFT LEVER	1	
7	STOP PLATE	1	
8	BOLT M8×11	1	
9	CIRCLIP 16	1	
10	SPRING	1	
11	SPRING SHAPE SPRING BASE	1	
			For installation, reverse the removal procedure.

CRANKSHAFT AND GEARSHIFT ARM

CRANKSHAFT AND GEARSHIFT ARM

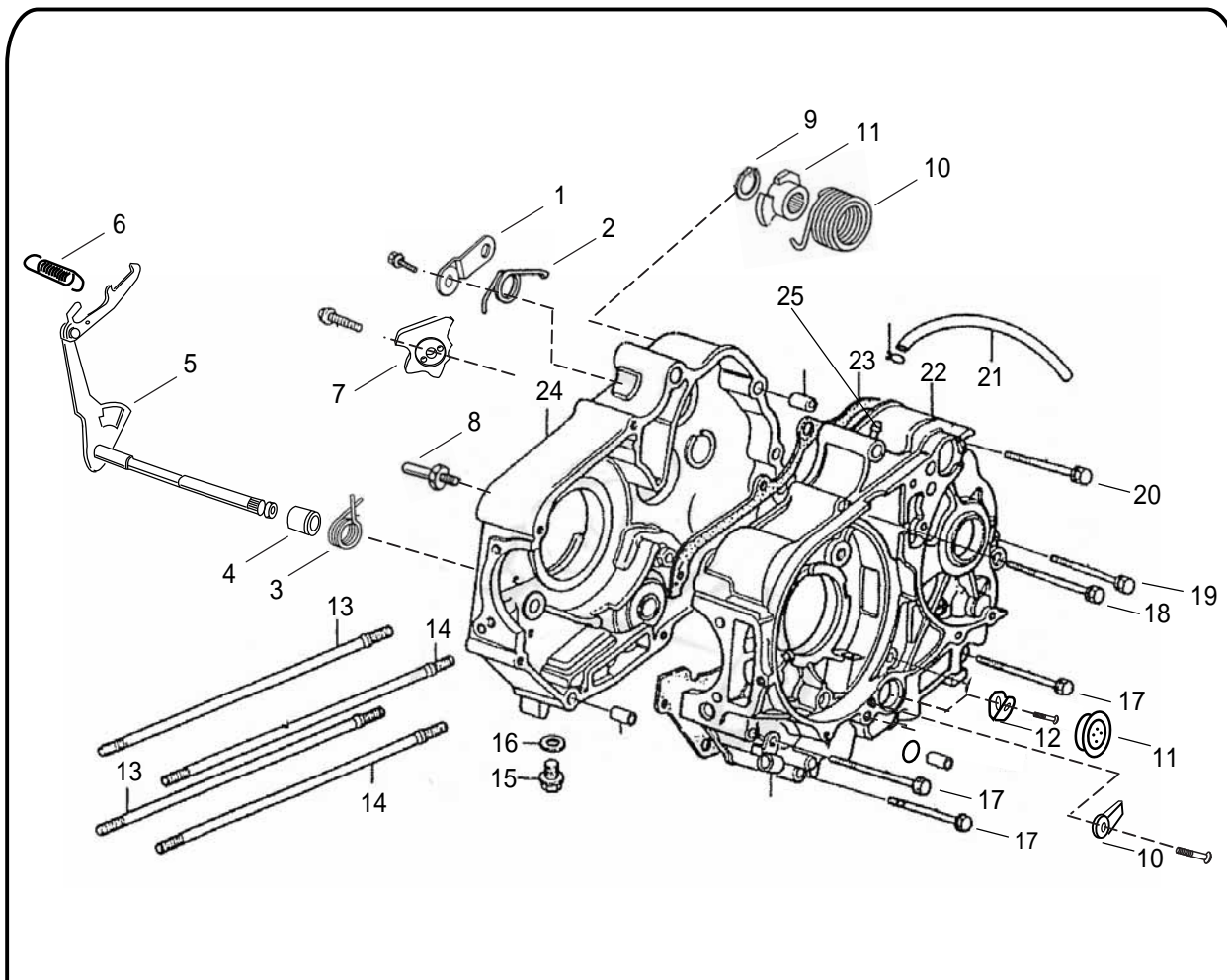

Order	Job / Part name	Q'ty	Remarks
			Remove the parts in the order listed.
12	CONTACT, GEAR INDICATION	1	
13	CYLINDER STUD BOLT B M7 X 204	2	
14	CYLINDER STUD BOLT A M7 X 212	2	
15	OIL DRAIN PLUG M12×1.5	1	
16	WASHER 12.5×1.5×20	1	
17	BOLT M6×65	3	
18	BOLT M6×60	1	
19	BOLT M6×45	1	
20	BOLT M6×60	1	
21	BREATHER TUBE C100-2#	1	
22	LEFT CRANKCASE	1	
23	GASKET, CRANKCASE	1	
24	RIGHT CRANKCASE	1	
25	TIE-IN, BREATHER TUBE	1	

For installation, reverse the removal procedure.

CRANKSHAFT AND GEARSHIFT ARM

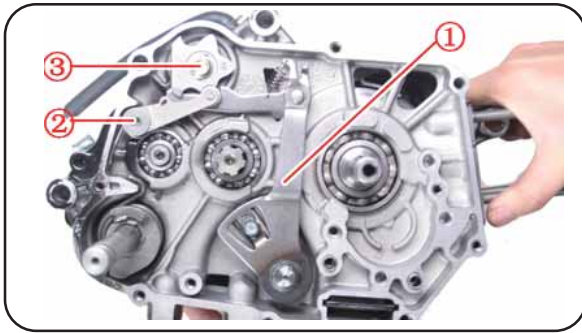

DISASSEMBLING THE CRANKCASE

1. Gearshift arm :

Remove:

- bolt of locating plate
- bolt of locating plate

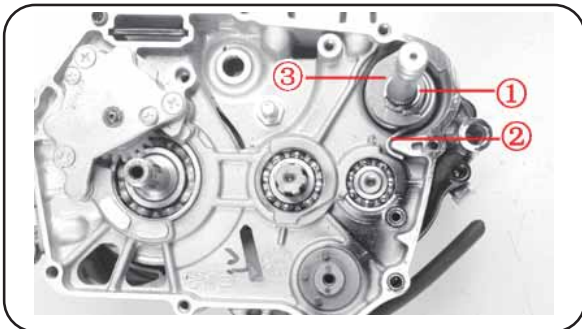
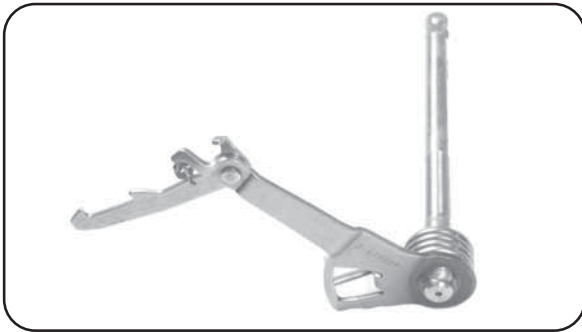

2. Remove:

- circlip
- spring
- spring seat

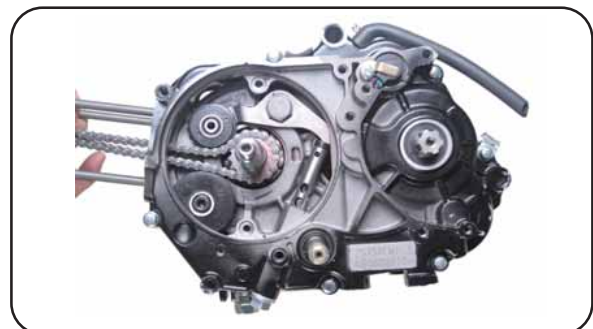

CRANKSHAFT

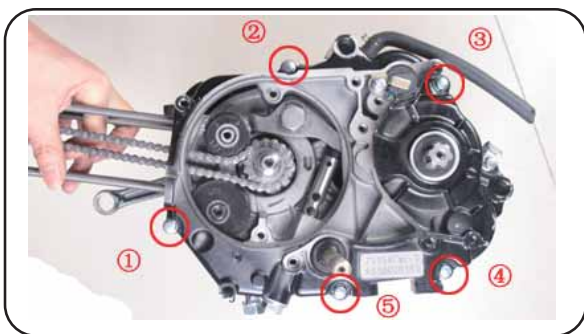

DISASSEMBLING THE CRANKCASE

1. Remove:

- crankcase bolts ① ~ ⑤

NOTE:

- Loosen each bolt 1/4 of a turn at a time, in stages and in a crisscross pattern. After all of the bolts are fully loosened, remove them.
- Loosen the bolts in decreasing numerical order (refer to the numbers in the illustration).
- The numbers embossed on the crankcase indicate the crankcase tightening sequence.



2. Remove:

- right crankcase

NOTE:

Set the left crankcase half under then put in the flat head screw driver to the separating slit .

CAUTION:

- First check that the shift drum segment's teeth and the drive axle circlip are properly positioned, then remove the right crankcase.
- Do not damage the crankcase mating surfaces.



CRANKSHAFT

CRANKSHAFT

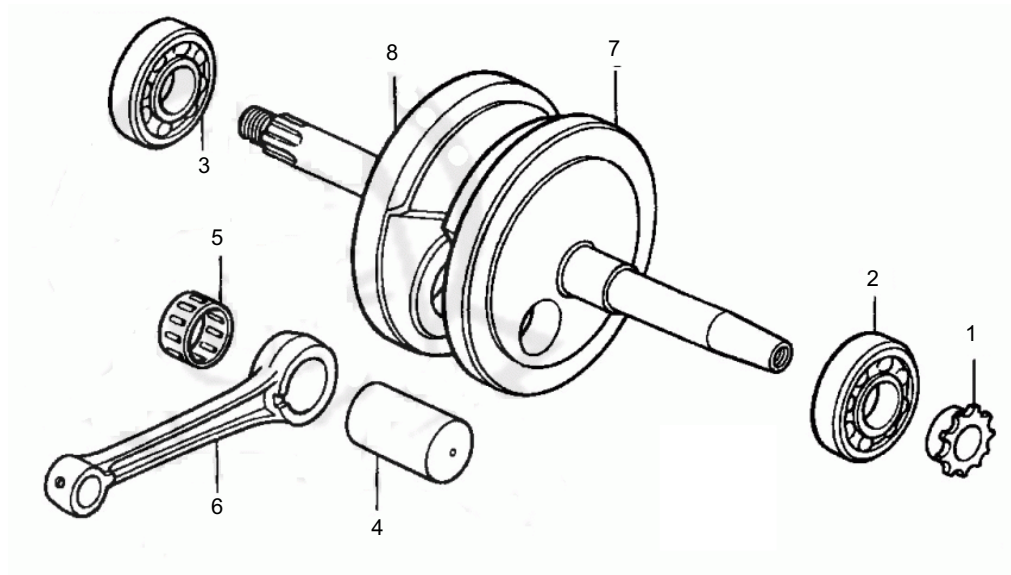

Order	Job / Part name	Q'ty	Remarks
			Remove the parts in the order listed.
1	TIMING DRIVE SPROCKET	1	
2	BEARING (6205)	1	
3	BEARING (6205)	1	
4	PIN	1	
5	ROLLER BEARING	1	
6	JOINT RED	1	
7	LEFT CRANKSHAFT	1	
8	RIGHT CRANKSHAFT	1	
			For installation, reverse the removal procedure.

CRANKSHAFT

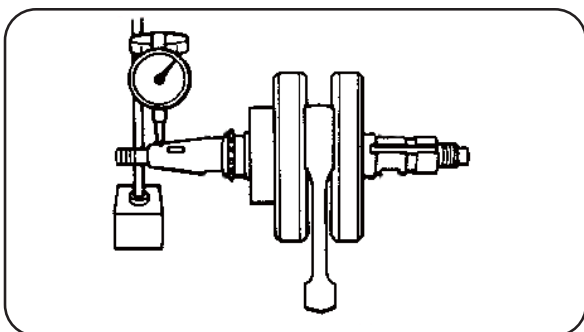

CHECKING THE CRANKSHAFT AND CONNECTING ROD

1. Measure:
 - crankshaft runout
Out of specification → Replace the crankshaft, bearing or both.

NOTE:

Turn the crankshaft slowly.

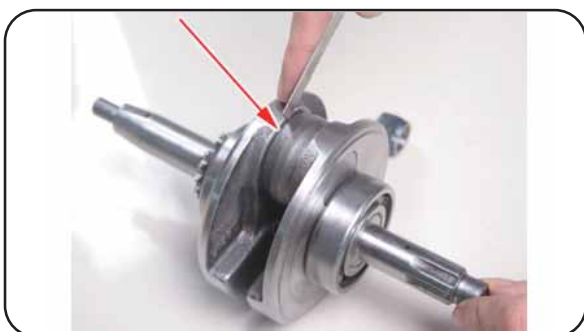

Crankshaft runout
Less than 0.03 mm

2. Measure:
 - big end axial clearance
Out of specification → Replace the big end bearing, crankshaft pin, or connecting rod.



Big end axial clearance
0.15 ~ 0.35 mm
Limit 0.6 mm



3. Measure:
 - crankshaft width
Out of specification → Replace the crankshaft.



Crankshaft width
40.15 ~ 40.20 mm



4. Check:
 - crankshaft sprocket ①
Damage/wear → Replace the crankshaft.
 - bearing ②
Cracks/damage/wear → Replace the crankshaft.

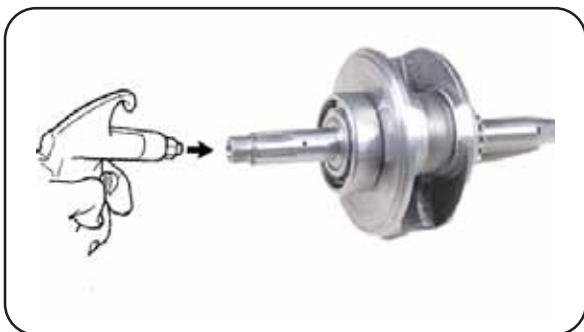

5. Check:
 - crankshaft journal
Scratches/wear → Replace the crankshaft.
 - crankshaft journal oil passage
Obstruction → Blow out with compressed air.

CRANKSHAFT



CHECKING THE BEARINGS AND OIL SEALS

1. Check:
 - bearings
Clean and lubricate the bearings, then rotate the inner race with your finger.
Rough movement → Replace.
2. Check:
 - oil seals
Damage/wear → Replace.

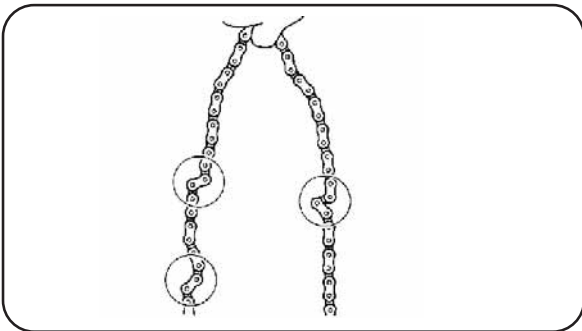

CHECKING THE TIMING CHAIN, CAM-SHAFT SPROCKET, AND TIMING CHAIN GUIDES

1. Check:
 - timing chain
Damage/stiffness → Replace the timing chain and camshaft sprocket as a set.
2. Check:
 - camshaft sprocket
More than 1/4 tooth^(a) wear → Replace the camshaft sprocket and the timing chain as a set.
 - (a) 1/4 tooth
 - (b) Correct
 - (1) Timing chain roller
 - (2) Camshaft sprocket
3. Check:
 - timing chain guide (exhaust side)
 - timing chain guide (intake side)
 - timing chain guide (top side)
Damage/wear → Replace the defective part(-s).

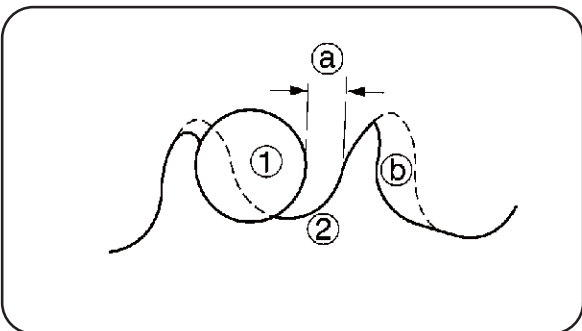

CRANKSHAFT

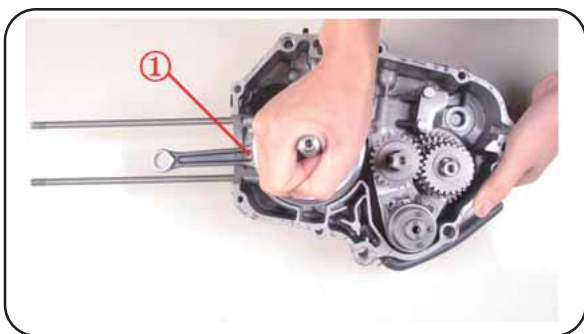

INSTALLING THE CRANKSHAFT

1. Install:
 - crankshaft ①

CAUTION:

To avoid scratching the crankshaft and to ease the installation procedure, apply grease onto the oil seal lips and apply engine oil onto each bearing.

ASSEMBLING THE CRANKCASE

1. Thoroughly clean all the gasket mating surfaces and crankcase mating surfaces.
2. Apply:
 - sealant (onto the crankcase mating surfaces)

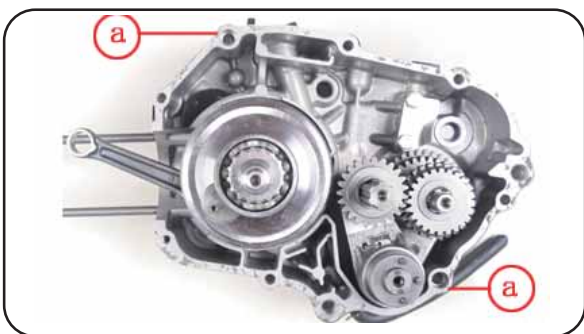

NOTE:

Do not allow any sealant to come into contact with the oil gallery (a).

3. Install:
 - dowel pins
 - right crankcase

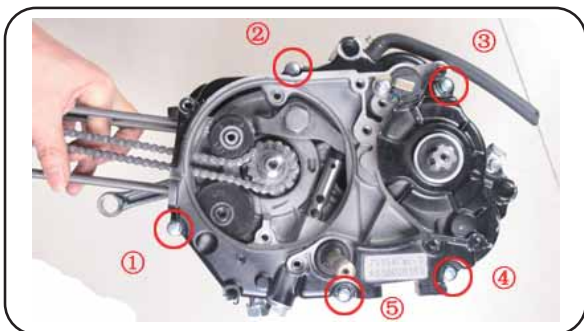

4. Tighten:
 - crankcase right half

 10 Nm (1.0 m•kg)

NOTE:

Tighten the screws in decreasing numerical order (see numbers on the illustration).

TRANSMISSION DEVICE,SHIFT DRUM ,GEAR FORKS

TRANSMISSION DEVICE,SHIFT DRUM ,GEAR FORKS

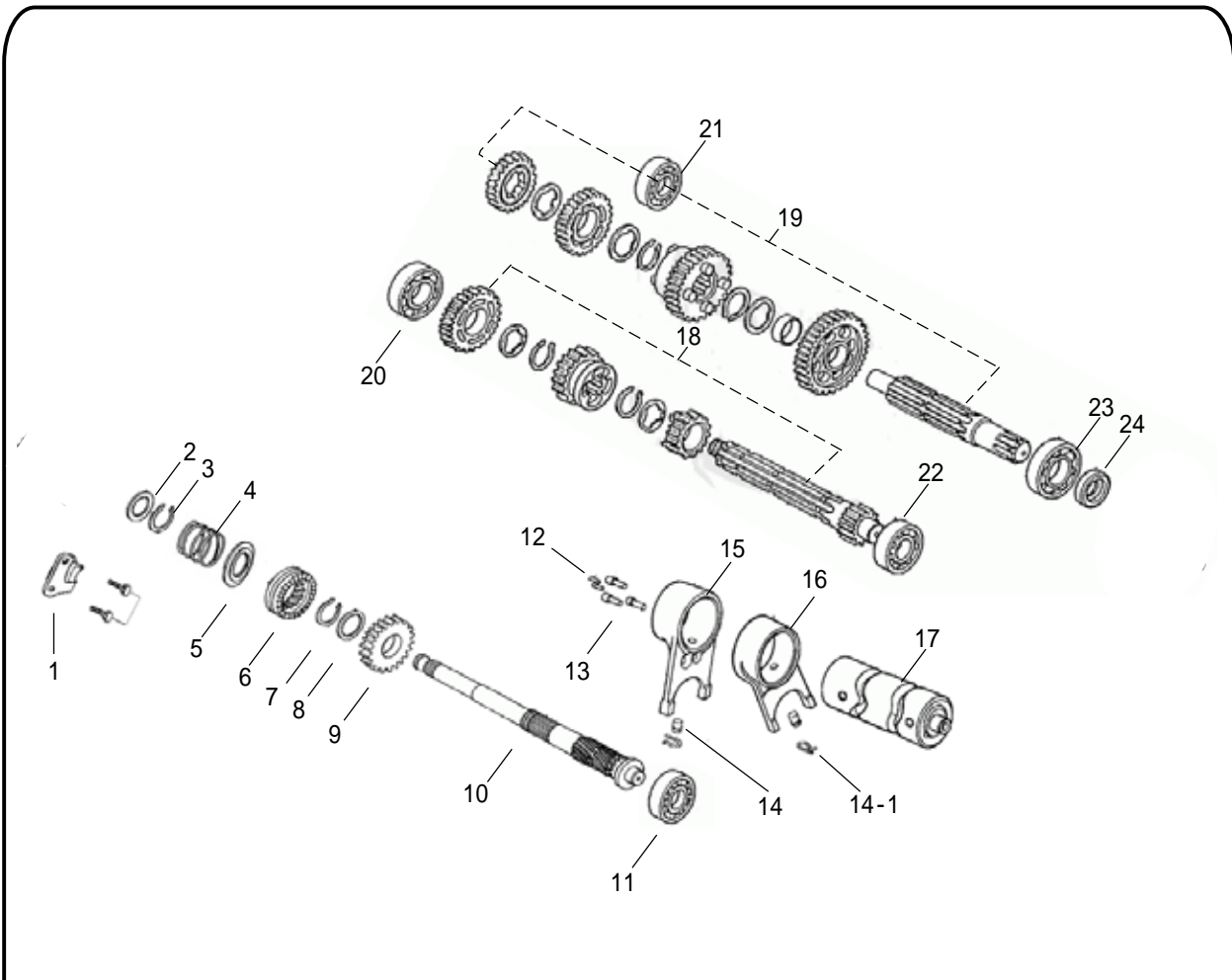

Order	Job / Part name	Q'ty	Remarks
			Remove the parts in the order listed.
1	RATCHET SPRING PLATE	1	
2	WASHER 17	1	
3	CIRCLIP	1	
4	SPRING	1	
5	RATCHET SPRING BASE	1	
6	STARING RATCHET WHEEL	1	
7	CIRCLIP	1	
8	WASHER	1	
9	STARING GEAR	1	
10	SPRING SHAPE	1	
11	BEARING	1	
12	PIN	2	
13	PIN	3	
14	PIN	2	
14-1	PRING CLIP	2	
15	GEAR FORK	1	
16	GEAR FORK	1	
17	DRUM	1	
			For installation, reverse the removal procedure.

TRANSMISSION DEVICE,SHIFT DRUM ,GEAR FORKS

TRANSMISSION DEVICE,SHIFT DRUM ,GEAR FORKS

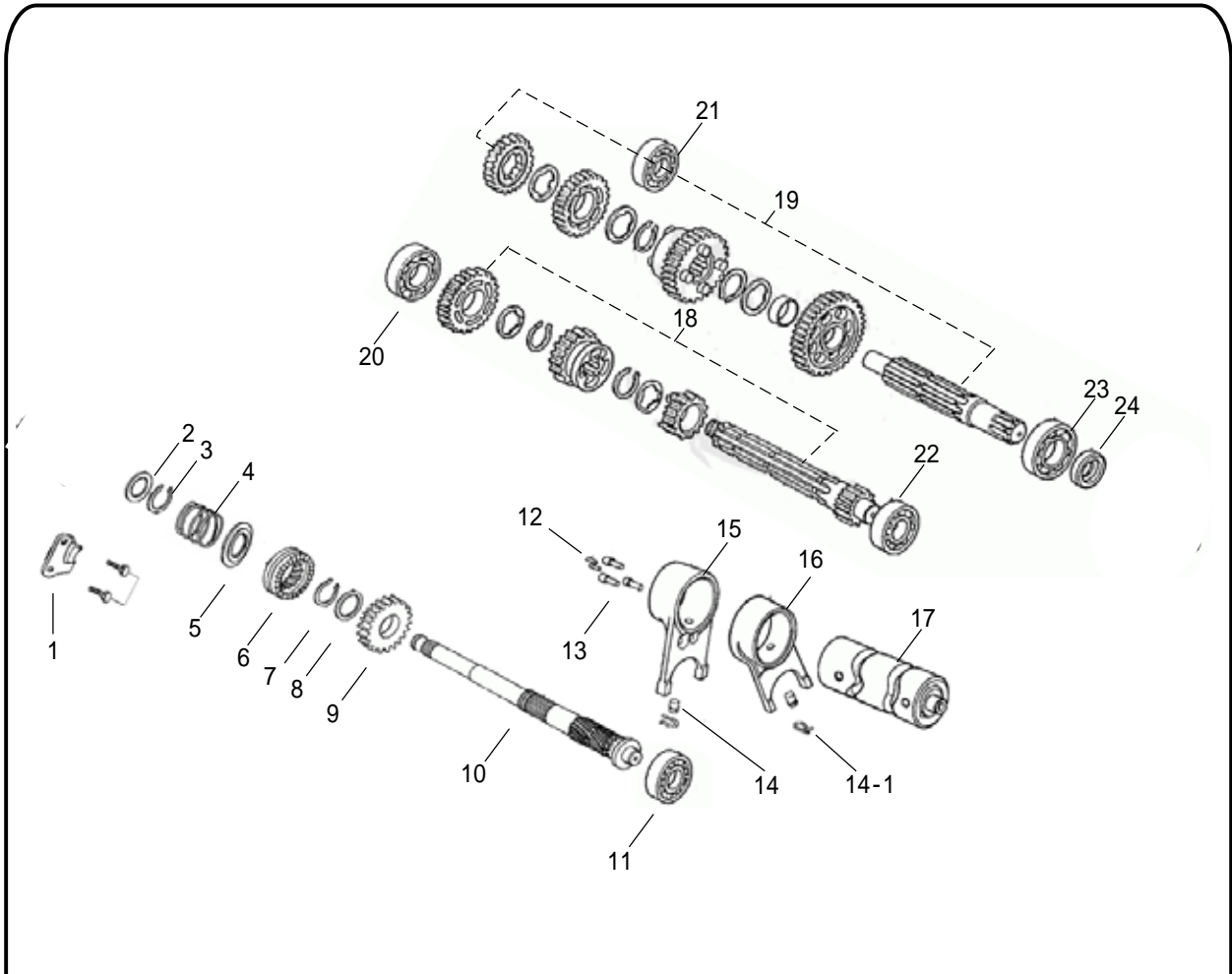

Order	Job / Part name	Q'ty	Remarks
18	MAINSHAFT	1	Remove the parts in the order listed.
19	COUNTERSHAFT	1	
20	BEARING 6203	1	
21	BEARING 6201	1	
22	BEARING 6001	1	
23	BEARING 6203	1	
24	OIL SEAL 17X29X5	1	
			For installation, reverse the removal procedure.

TRANSMISSION DEVICE,SHIFT DRUM ,GEAR FORKS

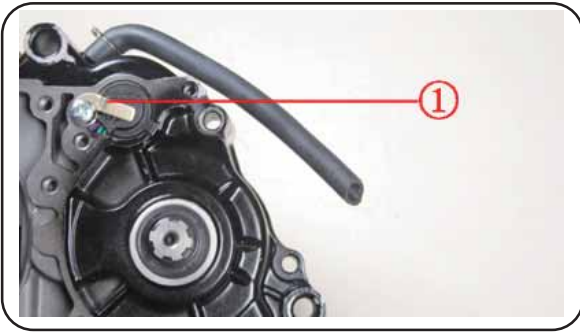

REMOVING THE TRANSMISSION

1. Loosen:
 - screw ①

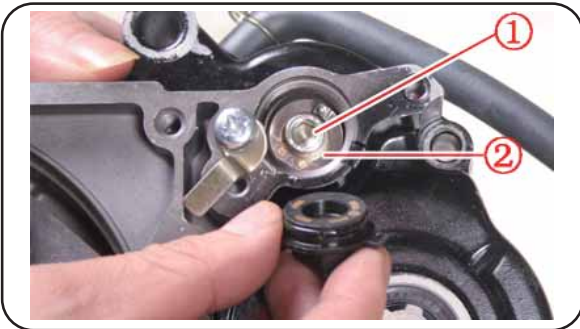

2. Remove:
 - screw ①
 - contact ,gear indication ②

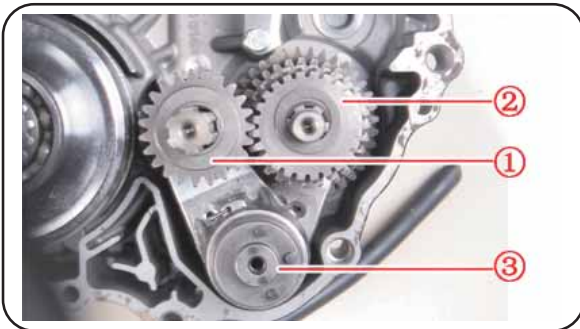

3. Remove:
 - drive axle assembly ①
 - main axle assembly ②
 - gearshift drum assy ③Remove them at same the time.



4. Gearshift drum assy disassembly.

- Remove:
- clip. gearshift drum ①
 - pin. gearshift drum ②

TRANSMISSION DEVICE,SHIFT DRUM ,GEAR FORKS

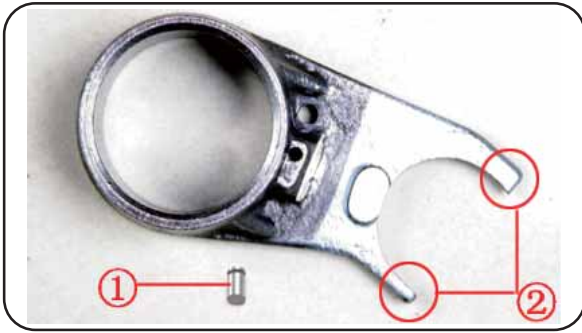

CHECKING THE SHIFT FORKS

The following procedure applies to all of the shift forks and related components.

Check:

- shift fork cam follower ①
- shift fork pawl ②

Bends/damage/scoring/wear → Replace the shift fork.

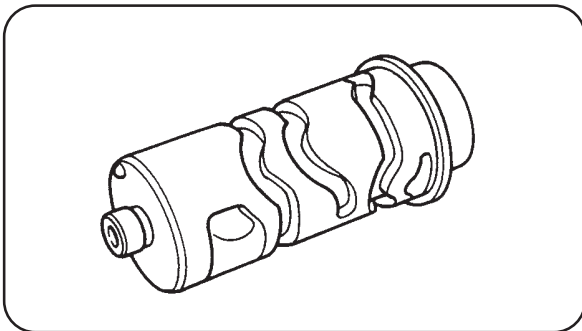

CHECKING THE SHIFT DRUM

1. Check:

- shift drum grooves
Damage/scratches/wear → Replace the shift drum.
- shift drum segment
Damage/wear → Replace.

TRANSMISSION DEVICE, SHIFT DRUM, GEAR FORKS

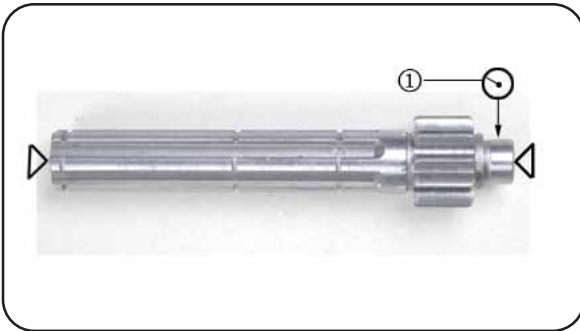

CHECKING THE TRANSMISSION

1. Measure:
 - main axle runout
(with a centering device and dial gauge ①)
Out of specification → Replace the main axle.

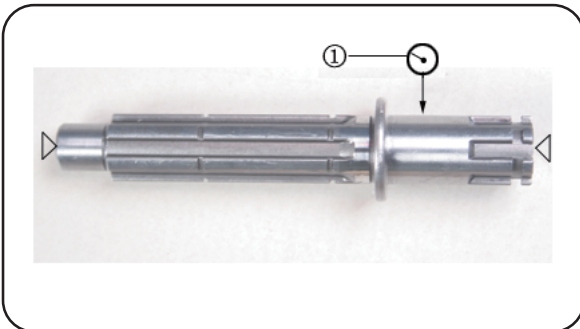

2. Measure:
 - drive axle runout
(with a centering device and dial gauge ①)
Out of specification → Replace the drive axle.



3. Check:
 - transmission gears
Blue discoloration/pitting/wear → Replace the defective gear(-s).

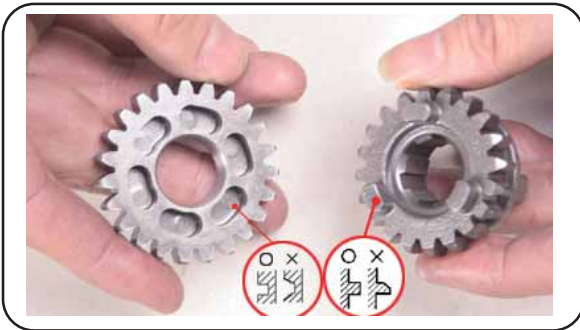

- transmission gear dogs
Cracks/damage/rounded edges → Replace the defective gear(-s).



4. Check:
 - transmission gear engagement
Incorrect → Reassemble the transmission axle assemblies.
5. Check:
 - transmission gear movement
Rough movement → Replace the defective part(-s).
6. Check:
 - circlips
Damage/bends/looseness → Replace.

TRANSMISSION DEVICE,SHIFT DRUM ,GEAR FORKS

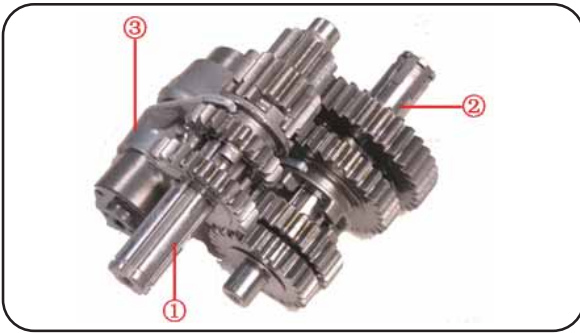

INSTALLING THE TRANSMISSION, SHIFT FORKS AND SHIFT DRUM

1. Install:

- main axle ①
- drive axle ②
- gearshift drum assy ③

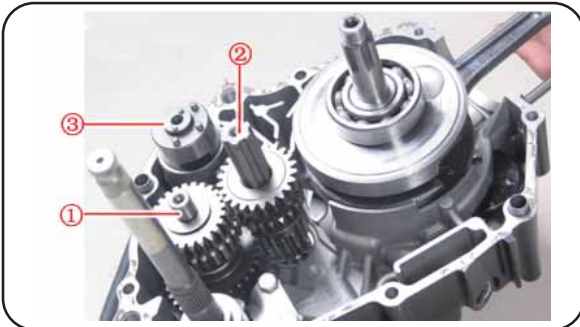

Put them into the crankcase at same the time.



2. Check:

- shift cam operation
Unsmoothy operation → Repair.

NOTE: _____

Check the transmission and shift forks for smooth operation by turning the shift cam with your hand.

FRONT WHEEL AND REAR WHEEL

FRONT WHEEL

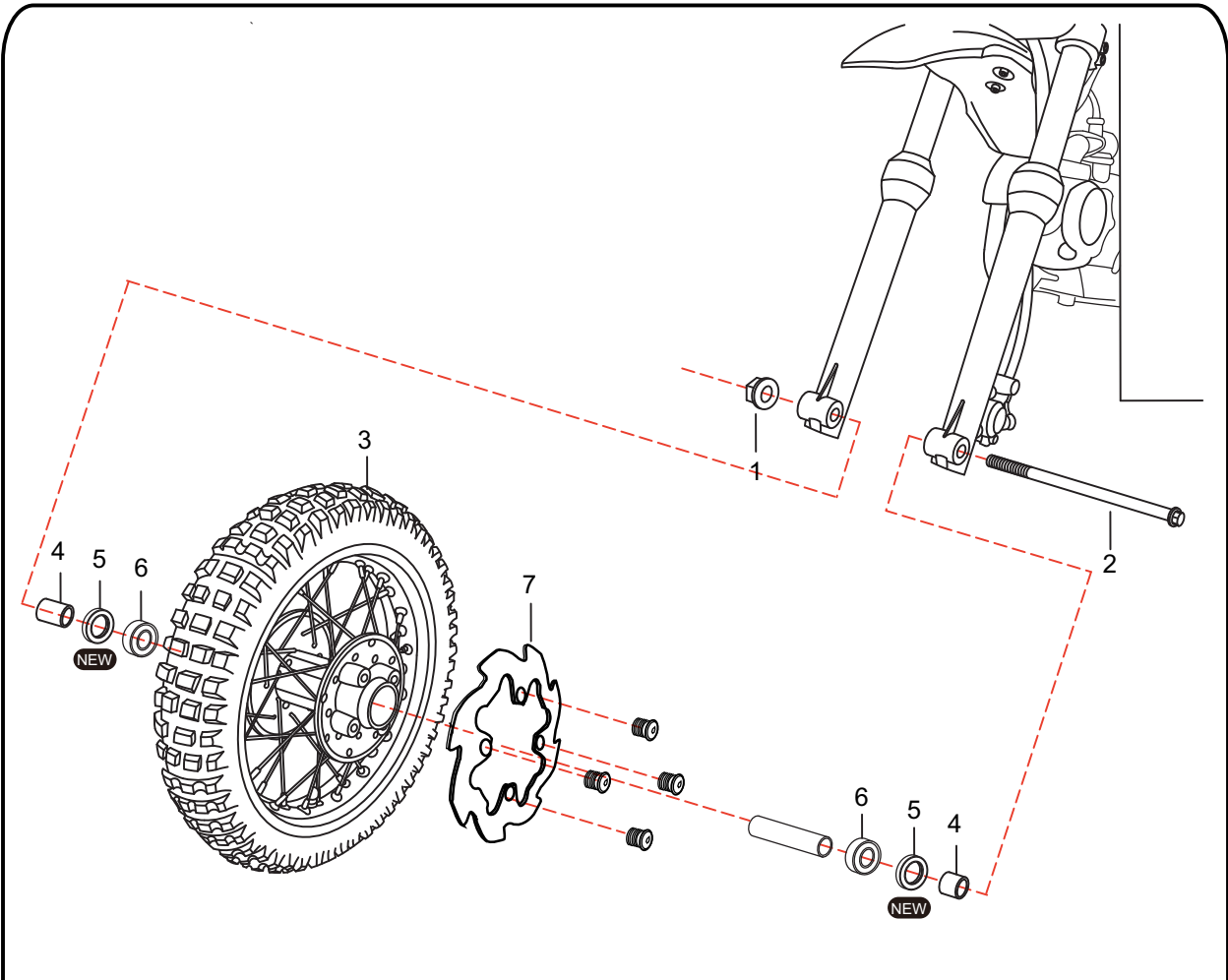

Order	Job / Part name	Q'ty	Remarks
			Remove the parts in the order listed.
1	NUT(FRONT WHEEL AXLE)	1	
2	FRONT RIM AXLE	1	
3	FRONT TIRE	1	
4	COLLAR , FR.WHEEL	2	
5	OIL SEAL	2	
6	BEARING	2	
7	FRONT-BRAKE DISK	1	For installation, reverse the removal procedure.

FRONT WHEEL AND REAR WHEEL

REAR WHEEL

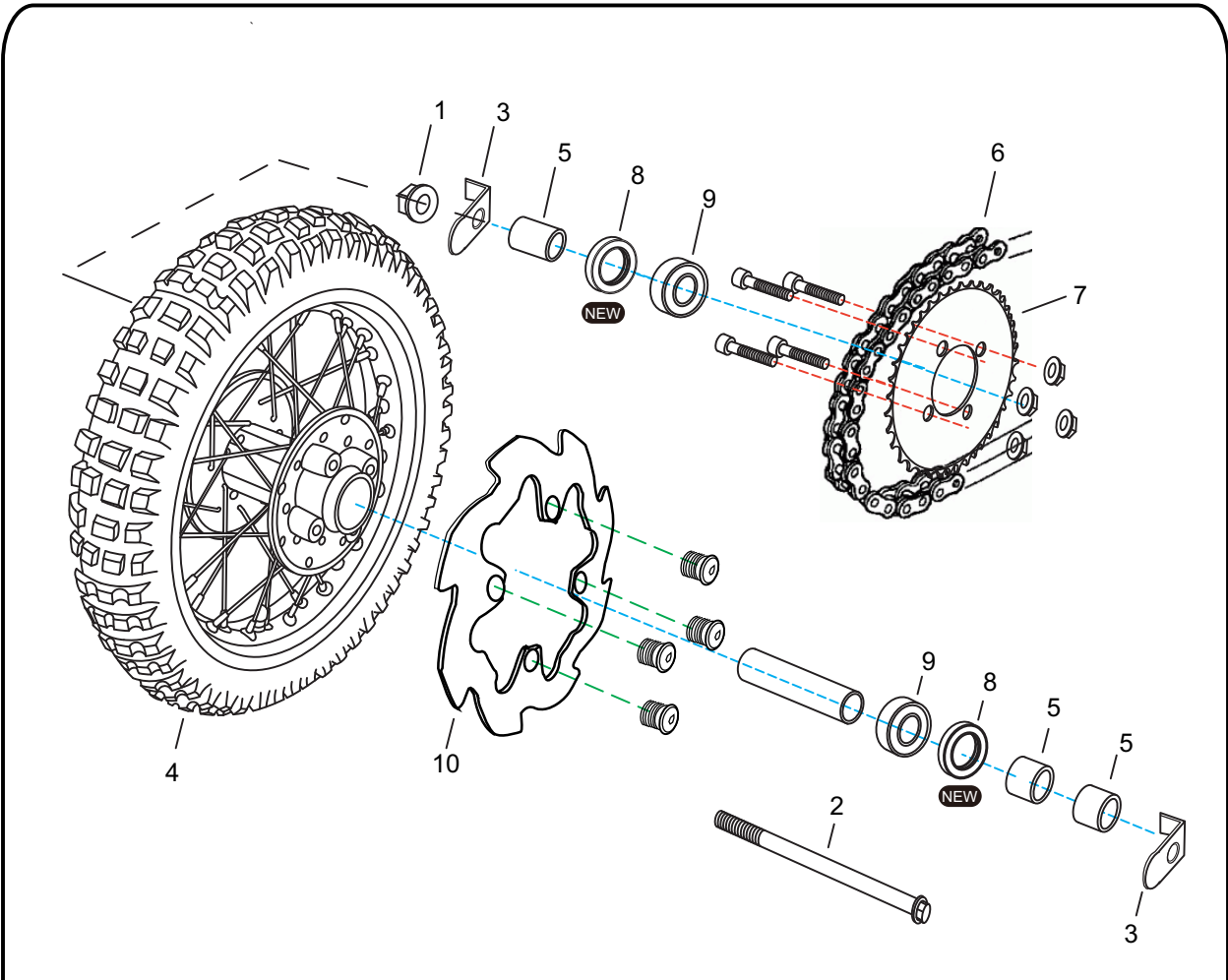

Order	Job / Part name	Q'ty	Remarks
			Remove the parts in the order listed.
1	NUT(FRONT WHEEL AXLE)	1	
2	FRONT RIM AXLE	1	
3	CHAIN PULLER	2	
4	REAR WHEEL	1	
5	COLLAR , RE.WHEEL	3	
6	DRIVEN SPROKET	1	
7	OIL SEAL	2	
8	BEARING	2	
9	FRONT-BRAKE DISK	1	

For installation, reverse the removal procedure.

FRONT WHEEL AND REAR WHEEL



REMOVAL POINTS

Rear wheel

1. Remove:
 - Wheel

NOTE: _____
Push the wheel forward and remove the drive chain .

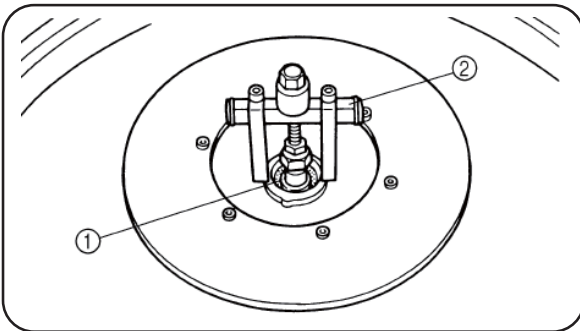

Wheel bearing (if necessary)

1. Remove:
 - Bearing

NOTE: _____
Remove the bearing using a general bearing puller .

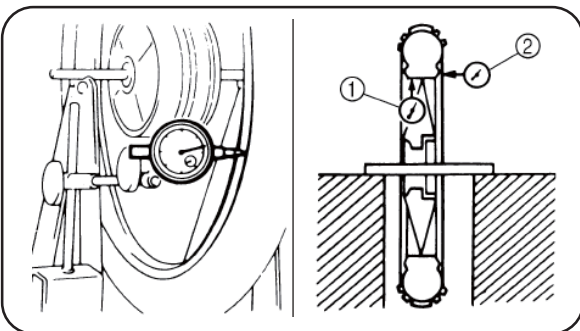

INSPECTION

Wheel

1. Measure:
 - Wheel runoutOut of limit → Repair/replace.



Wheel runout limit:
Radial : 2.0 mm
Lateral : 2.0 mm

2. Inspect:
 - BearingRotate inner race with a finger.
Rough spot/seizure → Replace.

NOTE: _____
Replace the bearings, oil seal and wheel collar as a set.

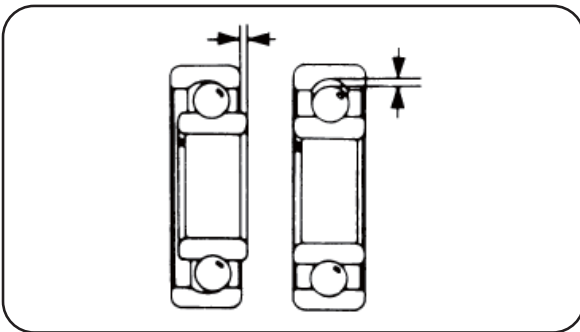

FRONT WHEEL AND REAR WHEEL

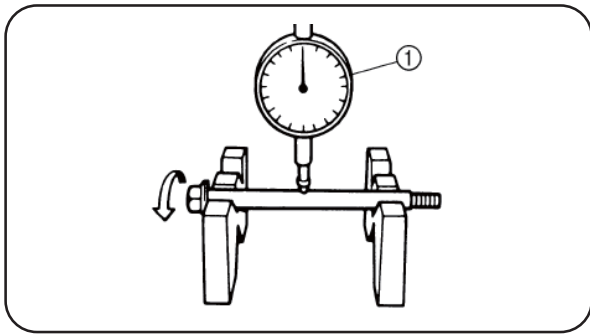

Wheel axle

1. Measure:
 - Wheel axle bends
Out of specification → Replace.
Use the dial gauge .



Wheel axle bending limit:
0.5 mm

NOTE:

The bending value is shown by one half of the dial gauge reading.

WARNING

Do not attempt to straighten a bent axle.

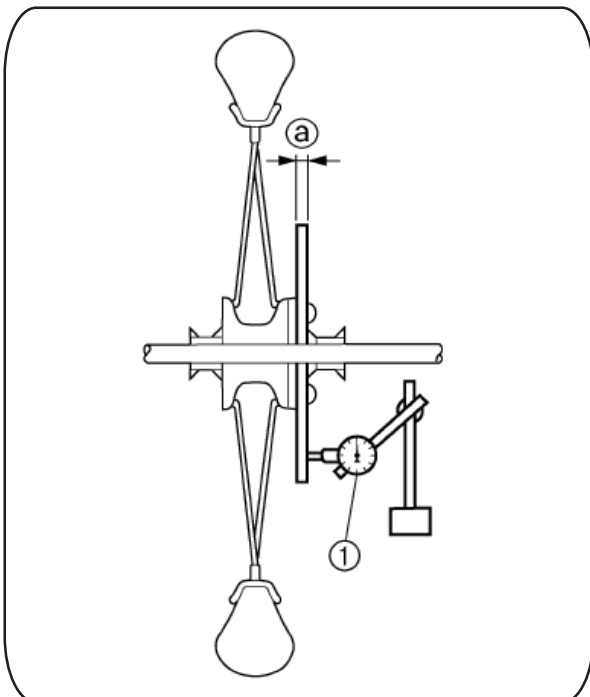

Brake disc

1. Measure:
 - Brake disc deflection (only rear brake disc)
Use the dial gauge .
Out of specification → Inspect wheel runout.
If wheel runout is in good condition, replace the brake disc.



Brake disc deflection limit:
Rear:
<Limit>: 0.15 mm

2. Measure:

- Brake disc thickness (a)
Out of limit → Replace.



Brake disc thickness:
Front:
3.0 mm
<Limit>: 2.5 mm
Rear:
3.0 mm
<Limit>: 2.5 mm

FRONT WHEEL AND REAR WHEEL

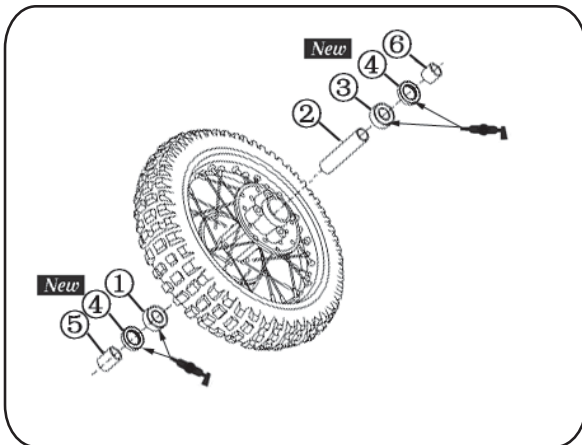

ASSEMBLY AND INSTALLATION

Front wheel

1. Install:
 - Bearing (left)
 - Middle spacer
 - Bearing (right)
 - Oil seal **New**
 - Collar (left)
 - Collar (right)

NOTE:

- Apply the lithium soap base grease on the bearing and oil seal lip when installing.
- Use a socket that matches the outside diameter of the race of the bearing.
- Left side of bearing shall be installed first.
- Install the oil seal with its manufacture's marks or numbers facing outward.

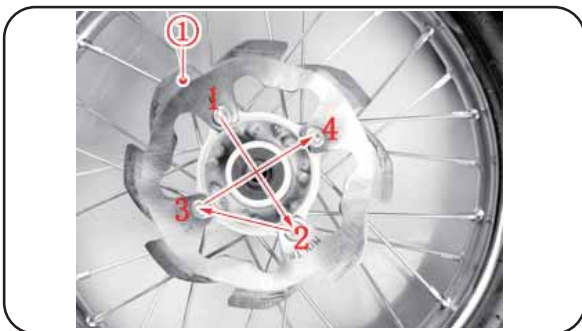

CAUTION:

Do not strike the inner race of the bearing. Contact should be made only with the outer race.

2. Install:
 - Brake disc
 - Bolt (brake disc)

 **12 Nm (1.2 m • kg)**

NOTE:

Tighten the bolts in stage, using a crisscross pattern.

3. Install:
 - Collar

NOTE:

Apply the lithium soap base grease on the oil seal lip.

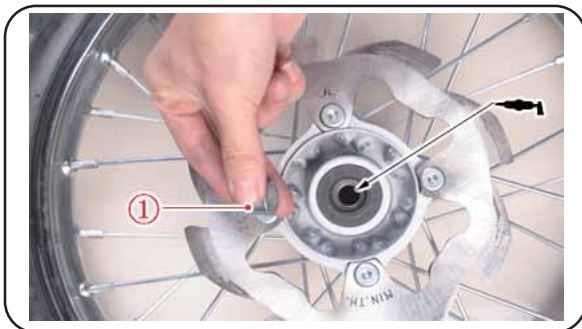

4. Install:
 - Wheel

NOTE:

Install the brake disc between the brake pads correctly.



FRONT WHEEL AND REAR WHEEL



5. Install:
 - Wheel axle

NOTE: _____
Apply the lithium soap base grease on the wheel axle.



6. Install:
 - Nut (wheel axle)

 **50Nm (5 m · kg)**

FRONT WHEEL AND REAR WHEEL

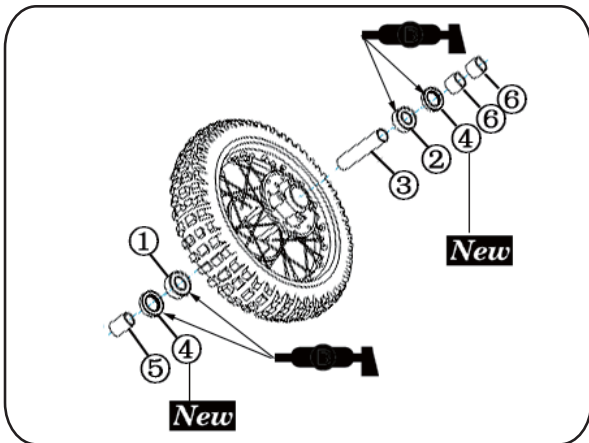

Rear wheel

1. Install:

- Bearing (left)
- Bearing (right)
- Middle spacer
- Oil seal **New**
- Left Collar
- Right Collar

NOTE:

- Apply the lithium soap base grease on the bearing and oil seal lip when installing.
- Install the bearing with seal facing outward.
- Use a socket that matches the outside diameter of the race of the bearing.
- Right side of bearing shall be installed first.
- Install the oil seal with its manufacture's marks or numbers facing outward.

CAUTION:

Do not strike the inner race of the bearing. Contact should be made only with the outer race.

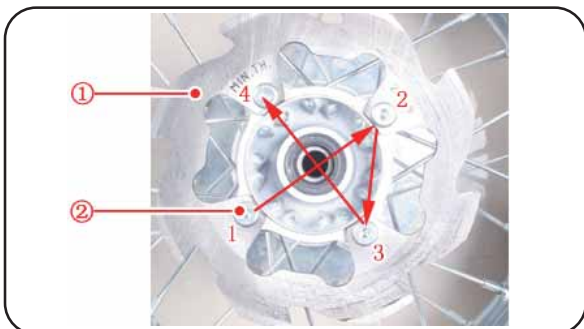

2. Install:

- Brake disc
- Bolt (brake disc)

 **14 Nm (1.4 m · kg)**

NOTE:

Tighten the bolts in stage, using a crisscross pattern.

FRONT WHEEL AND REAR WHEEL

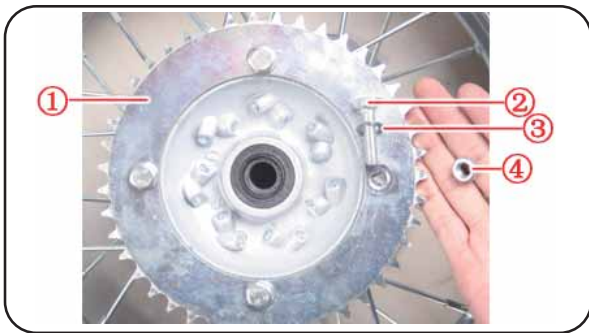

3. Install:

- Rear wheel sprocket
- Bolt (rear wheel sprocket)

 25 Nm (2.5m · kg)

- Washer (rear wheel sprocket)
- Nut (rear wheel sprocket)

NOTE: _____

Tighten the nuts in stage, using a crisscross pattern.



4. Install:

- Left Collar

NOTE: _____

Apply the lithium soap base grease on the oil seal lip.

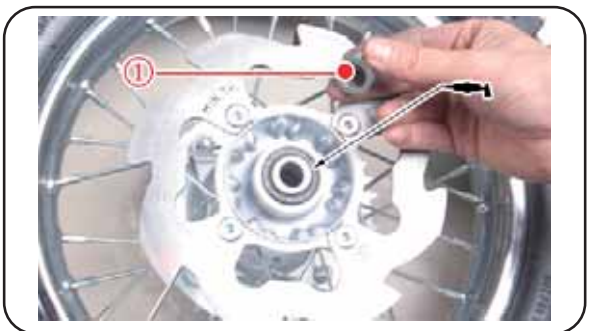

5. Install:

- Right Collar

NOTE: _____

Apply the lithium soap base grease on the oil seal lip.

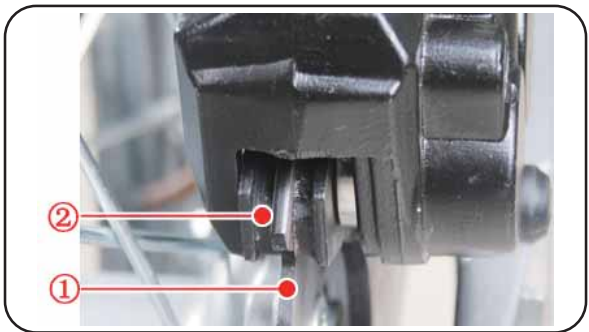

6. Install:

- Wheel

NOTE: _____

Install the brake disc between the brake pads correctly.



7. Install:

- Drive chain

NOTE: _____

Push the wheel forward and install the drive chain.

FRONT WHEEL AND REAR WHEEL

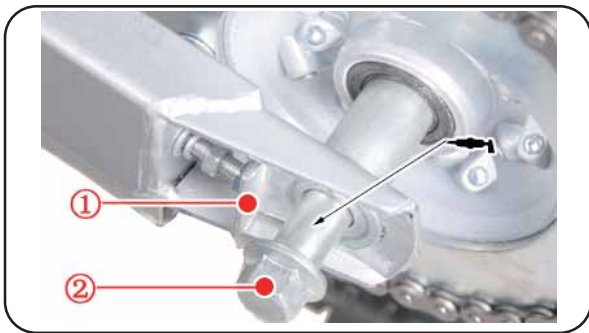

7. Install:
- Left drive chain puller
 - Wheel axle

NOTE: _____

- Install the left drive chain puller, and insert the wheel axle from left side.
- Apply the lithium soap base grease on the wheel axle.

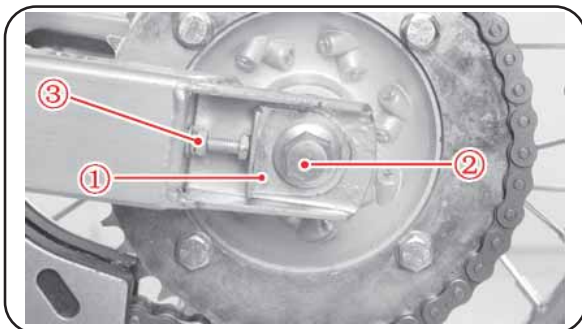

8. Install:
- Left drive chain puller
 - Bolt (wheel axle)
 - Adjust bolt (wheel axle)

NOTE: _____

Temporarily tighten the nut (wheel axle) at this point.

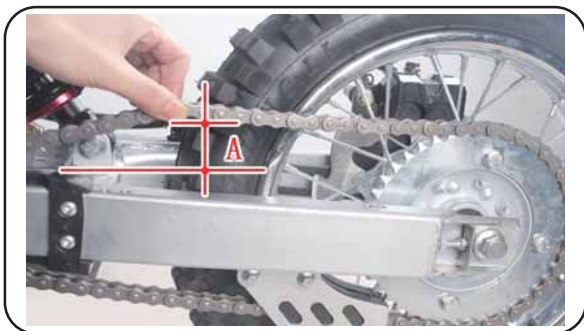

9. Adjust:
- Drive chain slack A



Drive chain slack:
30 ~ 40 mm

Refer to "DRIVE CHAIN SLACK ADJUSTMENT" section in the CHAPTER 3.

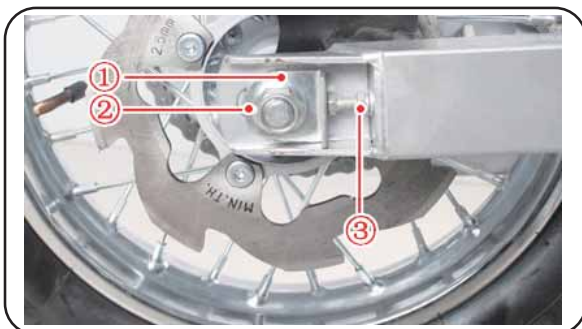

10. Tighten:
- Left drive chain puller
 - Nut (wheel axle)

 **65 Nm (6.5 m · kg)**

- Locknut

 **12 Nm (1.2 m · kg)**

FRONT BRAKE AND REAR BRAKE

FRONT BRAKE

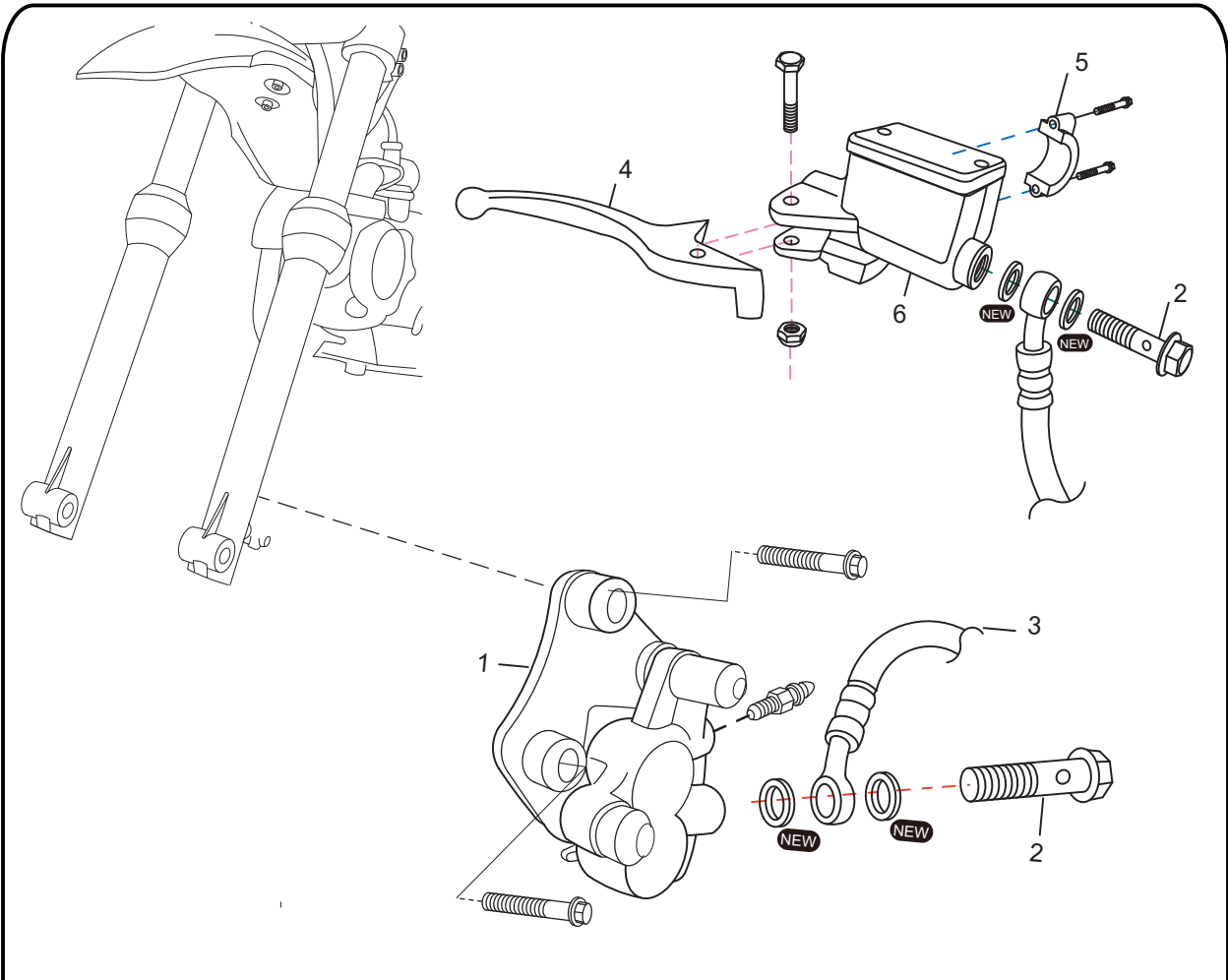

Order	Job / Part name	Q'ty	Remarks
			Remove the parts in the order listed.
1	FR,CALIPER ASSY.	1	
2	UNION BOLT	2	
3	FR,BRAKE HOSE	1	
4	BRAKE LEVER	1	
5	BRAKE MASTER CYLINDER BRACKET	1	
6	BRAKE MASTER CYLINDER	2	

For installation, reverse the removal procedure.

FRONT BRAKE AND REAR BRAKE

REAR BRAKE

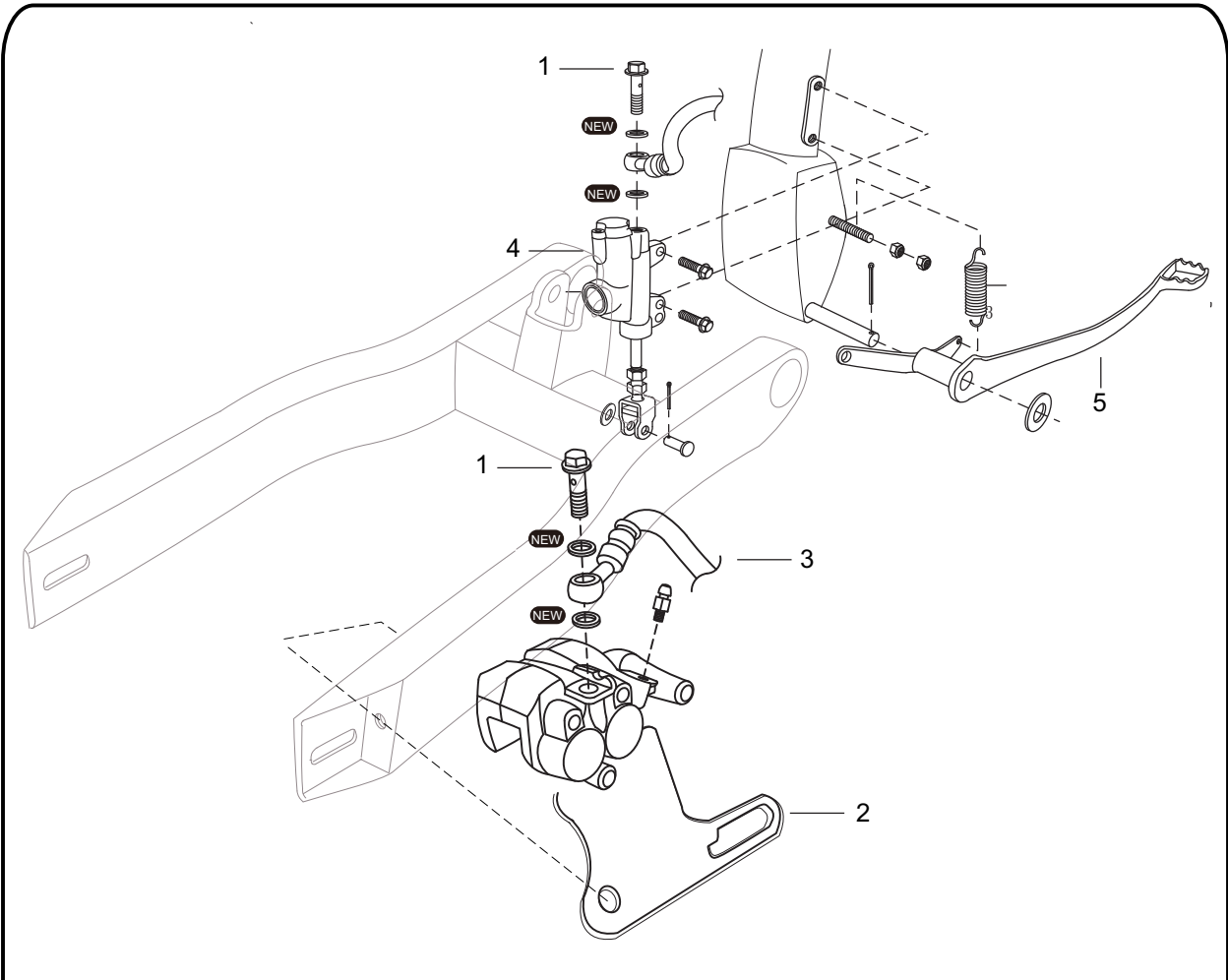

Order	Job / Part name	Q'ty	Remarks
			Remove the parts in the order listed.
1	UNION BOLT.	2	
2	REAR,CALIPER ASSY.	1	
3	REAR,BRAKE HOSE	1	
4	REAR MASTER CYLINDER ASSY	1	
5	REAR.BRAKE PEDAL	1	
			For installation, reverse the removal procedure.

FRONT WHEEL AND REAR WHEEL

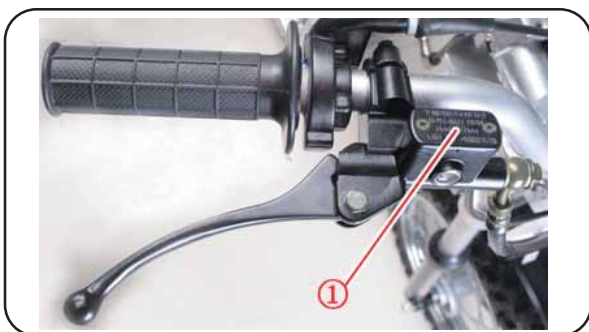

REMOVAL POINTS

Brake fluid

1. Remove:
[Front]
 - Brake master cylinder cap

NOTE: _____
Do not remove the diaphragm.



- [Rear]
 - Brake master cylinder cap

NOTE: _____
Do not remove the diaphragm.



2. Connect the transparent hose to the bleed screw and place a suitable container under its end.

3. Loosen the bleed screw and drain the brake fluid while pulling the lever in or pushing down on the pedal.

CAUTION: _____

- Do not reuse the drained brake fluid.
- Brake fluid may erode painted surfaces or plastic parts. Always clean up spilled fluid immediately.



FRONT WHEEL AND REAR WHEEL

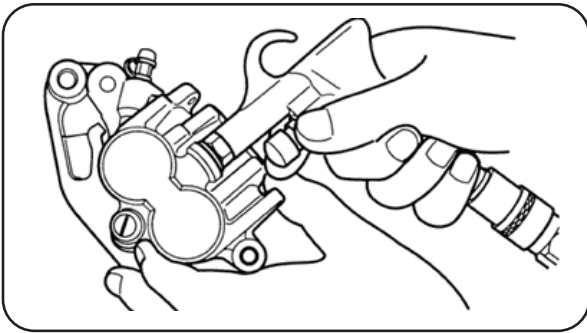

Brake caliper piston

1. Remove:
 - Brake caliper piston
Use compressed air and proceed carefully.

▲ WARNING

- Cover piston with rag and use extreme caution when expelling piston from cylinder.
- Never attempt to pry out piston.

Caliper piston removal steps:

- Insert a piece of rag into the brake caliper to lock one brake caliper.
- Carefully force the piston out of the brake caliper cylinder with compressed air.



Brake caliper piston and spring plate

1. Remove:
 - Piston (Brake caliper)
 - Pad support (Brake caliper)
Wear/damage/ → Replace

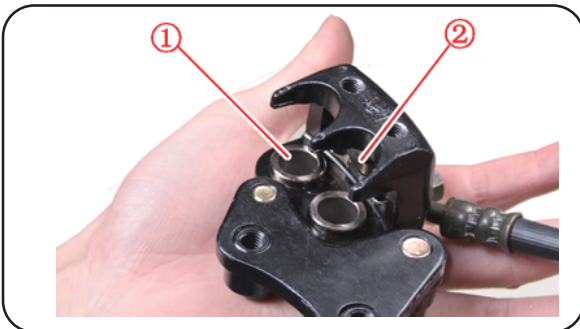

CAUTION:

Never attempt to take out the piston .

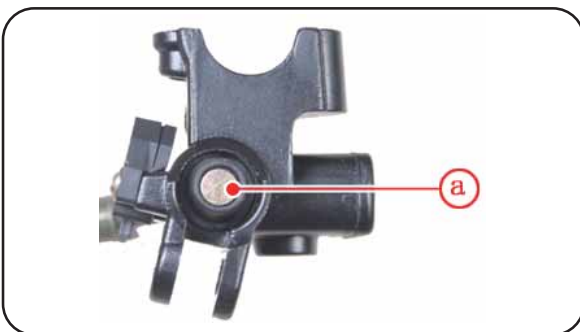

INSPECTION

Brake master cylinder

1. Inspect:
 - Brake master cylinder inner surface (a)
Wear/scratches → Replace master cylinder assembly.
Stains → Clean.

▲ WARNING

Use only new brake fluid.

FRONT WHEEL AND REAR WHEEL

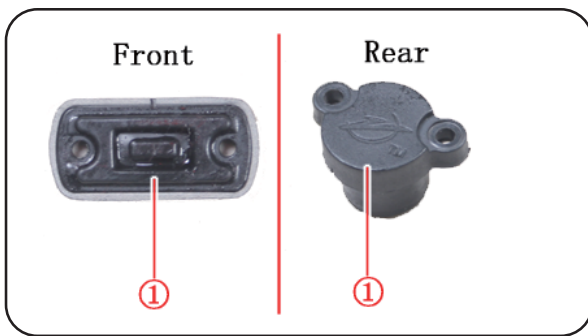

2. Inspect:
 - Diaphragm
Crack/damage → Replace.

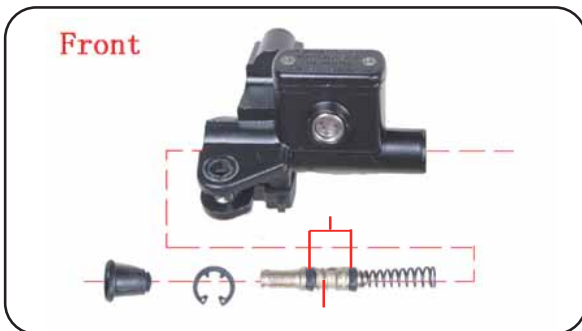

3. Inspect:
 - Brake master cylinder piston
 - Brake master cylinder cup
 - Wear/damage/score marks → Replace brake master cylinder kit.

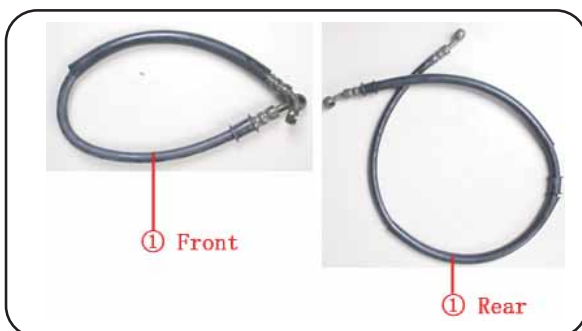
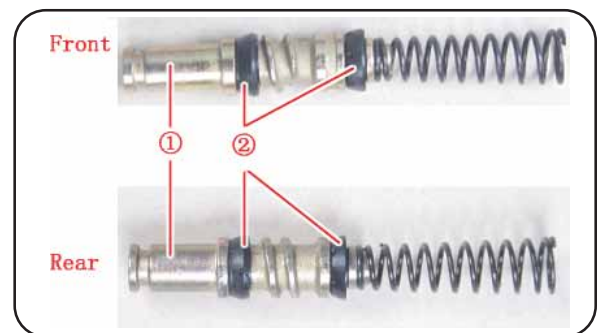
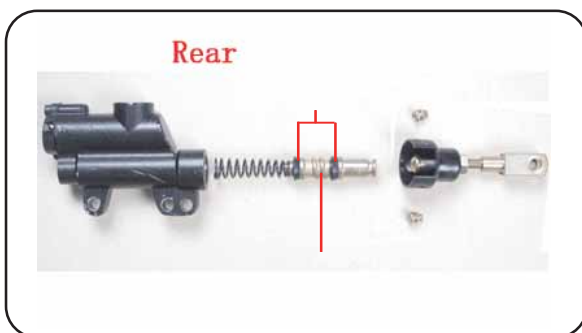

Brake hose

1. Inspect:
 - Brake hose
Crack/damage → Replace.

FRONT WHEEL AND REAR WHEEL

ASSEMBLY AND INSTALLATION

⚠ WARNING

- All internal parts should be cleaned in new brake fluid only.
- Internal parts should be lubricated with brake fluid when installed.

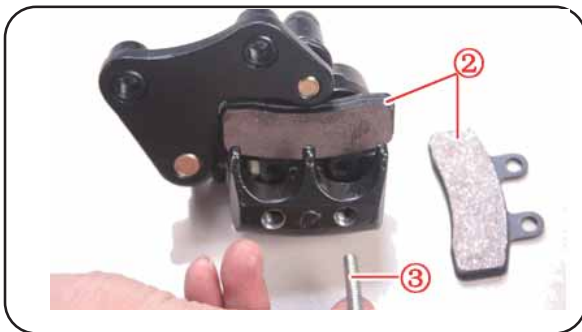

Front braker caliper

1. Install:
 - Pad support
 - Brake pad
 - Pad pin

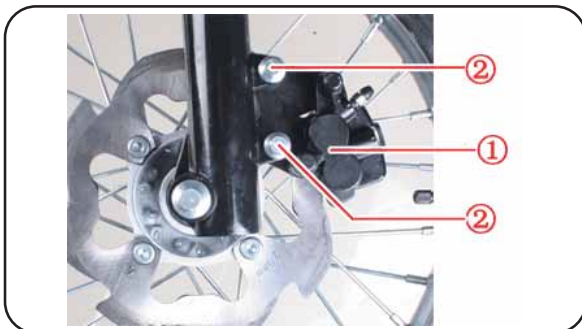

2. Install:
 - Brake caliper
 - Bolt (front brake caliper)

FRONT WHEEL AND REAR WHEEL

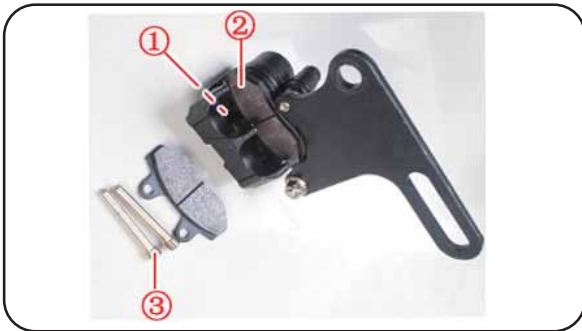

Rear braker caliper

1. Install:

- Pad support
- Brake pad
- Pad pin

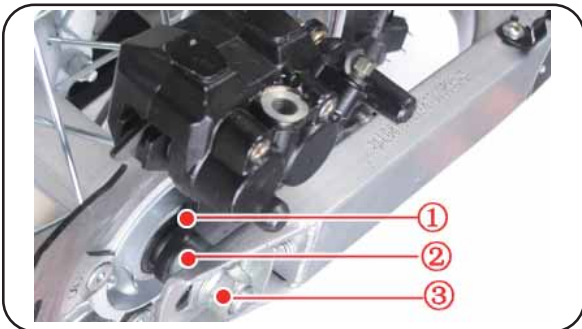

2. Install:

- Brake caliper
- Right spacer (rear wheel)
- Nut (rear wheel)

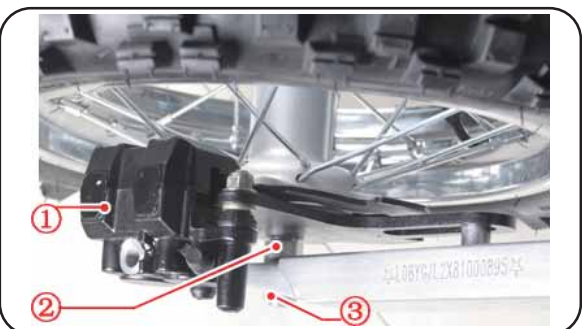

FRONT WHEEL AND REAR WHEEL

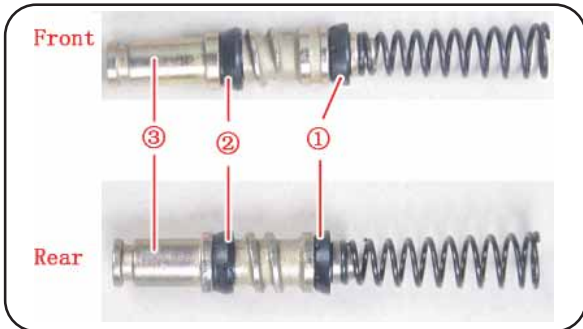

Brake master cylinder kit

1. Clean:
 - Brake master cylinder
 - Brake master cylinder kit
 Clean them with brake fluid.
2. Install:
 - Brake master cylinder cup (primary)
 - Brake master cylinder cup (secondary)
 To brake master cylinder piston

NOTE: _____
Apply the brake fluid on the brake master cylinder cup.

⚠ WARNING _____

After installing, cylinder cup should be installed as shown direction. Wrong installation cause improper brake performance.

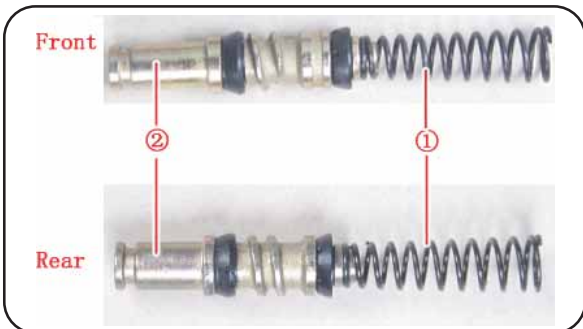

3. Install:
 - Spring
 To brake master cylinder piston .

NOTE: _____
Install the spring at the smaller dia. side.

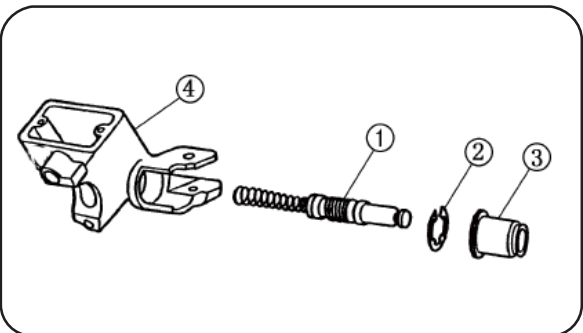

4. Install:

[Front]

 - Brake master cylinder kit
 - Circlip
 - Brake master cylinder boot
 To brake master cylinder .

[Rear]

 - Brake master cylinder kit
 - Push rod
 - Brake master cylinder boot
 - To brake master cylinder

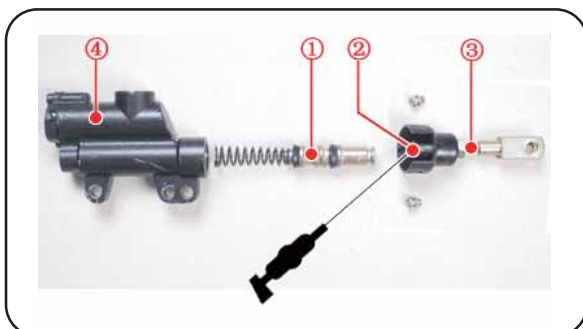

NOTE: _____
 • Apply the brake fluid on the brake master cylinder kit.
 • Apply the lithium soap base grease on the tip of the push rod.
 • When installing the circlip, use a long nose circlip pliers.

FRONT WHEEL AND REAR WHEEL

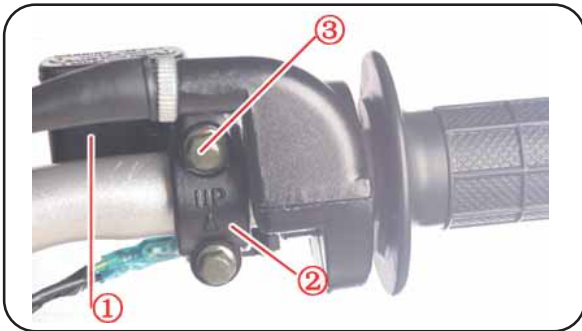

Front brake master cylinder

1. Install:

- Brake master cylinder
- Brake master cylinder bracket
- Bolt (brake master cylinder bracket)

 9 Nm (0.9 m • kg)

NOTE:

- Install the bracket so that the arrow mark a face upward.
- First tighten the bolts on the upper side of the brake master cylinder bracket, and then tighten the bolts on the lower side.



2. Install:

- Brake lever
- Bolt (brake lever)

 6 Nm (0.6 m • kg)

- Front brake master cylinder

NOTE:

Apply the lithium soap base grease on the brake lever sliding surface, bolt and contacting surface of the brake master cylinder piston.

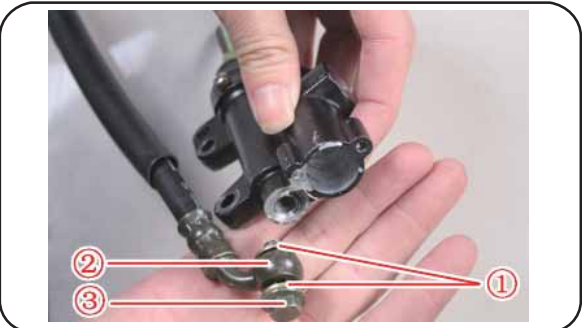

Rear brake master cylinder

1. Install:

- Copper washer **New**
- Brake hose
- Union bolt

 25 Nm (2.5 m • kg)

WARNING

Always use new copper washers.



CAUTION:

Install the brake hose so that its pipe portion directs as shown and lightly touches the projection on the brake master cylinder.

FRONT WHEEL AND REAR WHEEL

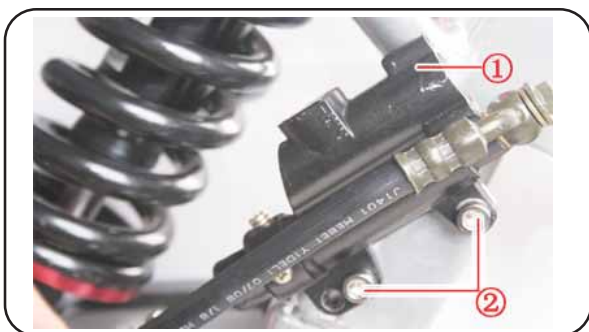

2. Install:
 - Brake master cylinder
 - Bolt (brake master cylinder)

 9 Nm (0.9 m · kg)

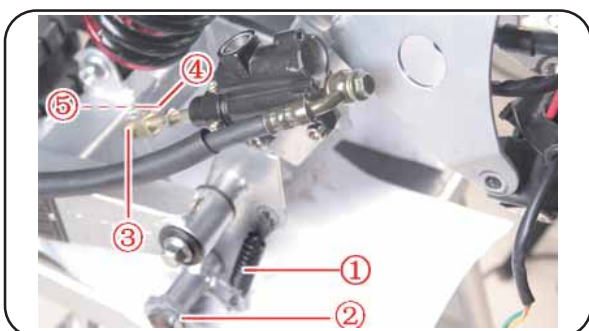

3. Install:
 - Spring
 - Brake pedal
 - Pin
 - Washer
 - Cotter pin

New

NOTE:

After installing, check the brake pedal height. Refer to "REAR BRAKE ADJUSTMENT" section in the CHAPTER 3 .



Front brake hose

1. Install:
 - Union bolt
 - Copper washer
 - Brake hose

 25 Nm (2.5 m · kg)

WARNING

Always use new copper washers.



CAUTION:

After installing, brake hose should be installed as shown direction. wrong installation case brake hose broken.

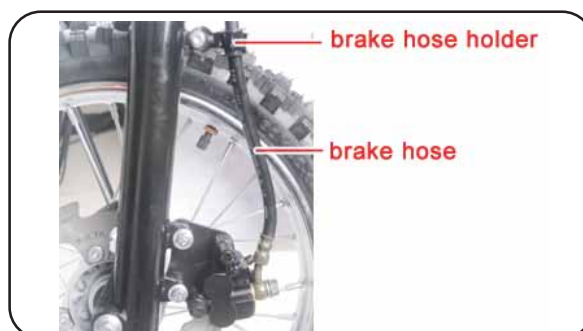

FRONT WHEEL AND REAR WHEEL

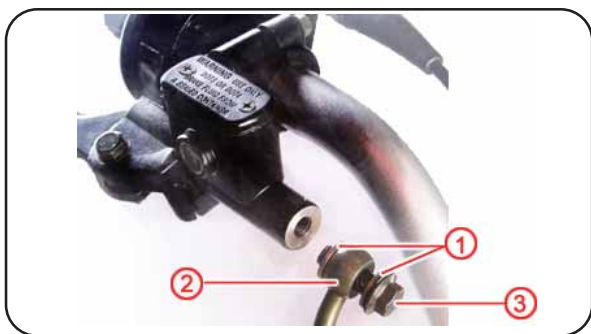

2. Install:

- Copper washer **New**
- Brake hose
- Union bolt

 25 Nm (2.5 m · kg)

▲ WARNING

Always use new copper washers.

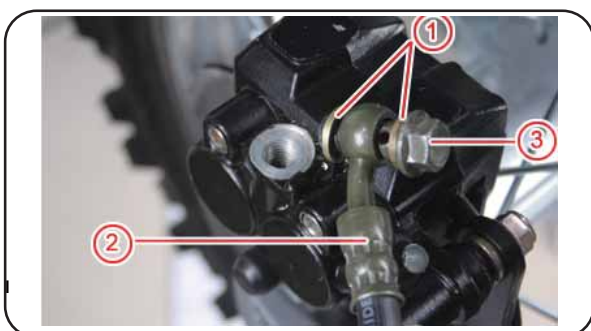

Rear brake hose

1. Install:

- Copper washer **New**
- Brake hose
- Union bolt

 25 Nm (2.5 m · kg)

▲ WARNING

Always use new copper washers.

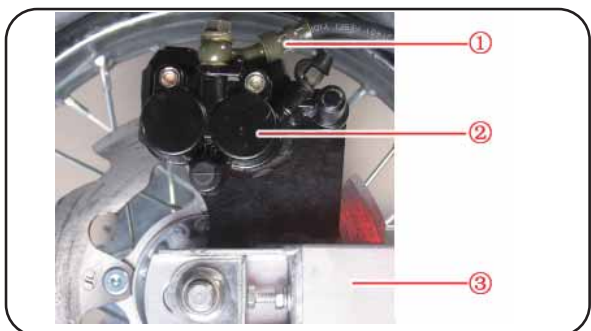

- Brake hose
- Brake caliper
- Swing arm

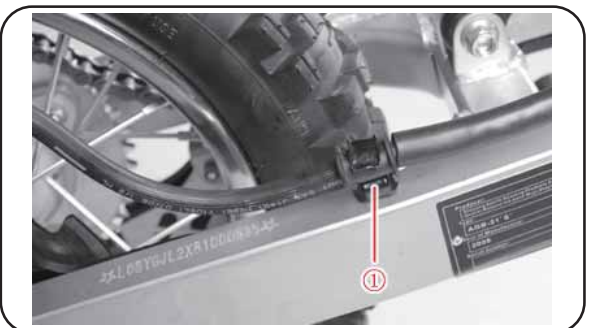

2. Install:

- Brake holder

CAUTION:

After installing, brake hose should be installed as shown direction. wrong installation case brake hose broken.

FRONT BRAKE AND REAR BRAKE

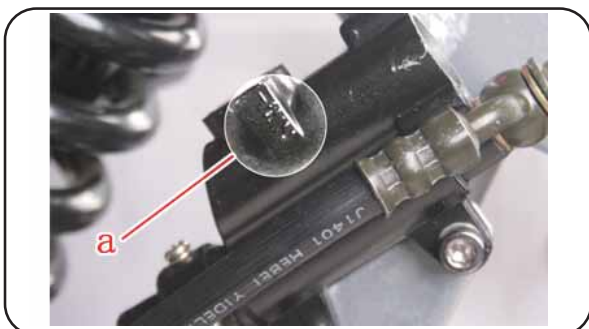

Brake fluid

1. Fill:
 - Brake fluid
Until the fluid level reaches "LOWER" level line .



**Recommended brake fluid:
DOT #3 or DOT #4**

▲ WARNING

- Use only the designated quality brake fluid:
otherwise, the rubber seals may deteriorate, causing leakage and poor brake performance.
- Refill with the same type of brake fluid; mixing fluids may result in a harmful chemical reaction and lead to poor performance.
- Be careful that water does not enter the master cylinder when refilling. Water will significantly lower the boiling point of the fluid and may result in vapor lock.

CAUTION:

Brake fluid may erode painted surfaces or plastic parts. Always clean up spilled fluid immediately.

2. Air bleed:
 - Brake system
Refer to "BRAKE SYSTEM AIR BLEEDING" section in the CHAPTER 3.
3. Inspect:
 - Brake fluid level
Fluid at lower level → Fill up.
Refer to "BRAKE FLUID LEVEL INSPECTION" section in the CHAPTER 3.

FRONT BRAKE AND REAR BRAKE

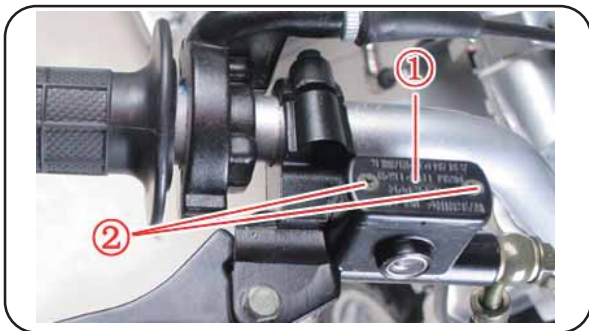

4. Install:

[Front]

- Diaphragm
- Brake master cylinder cap
- Screw (brake master cylinder cap)

 2 Nm (0.2 m · kg)

[Rear]

- Diaphragm
- Brake master cylinder cap
- Bolt (brake master cylinder cap)

 2 Nm (0.2 m · kg)

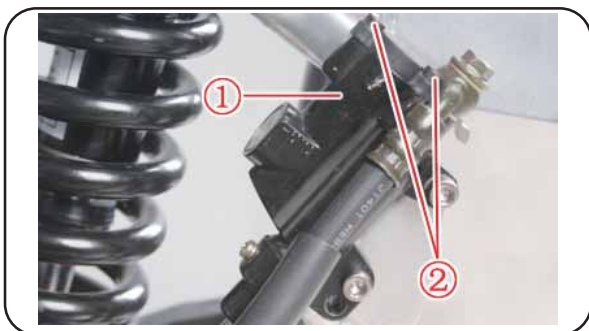

CAUTION:

After installation, while pulling the brake lever in or pushing down on the brake pedal, check whether there is any brake fluid leaking where the union bolts are installed respectively at the brake master cylinder and brake caliper.

STREERING

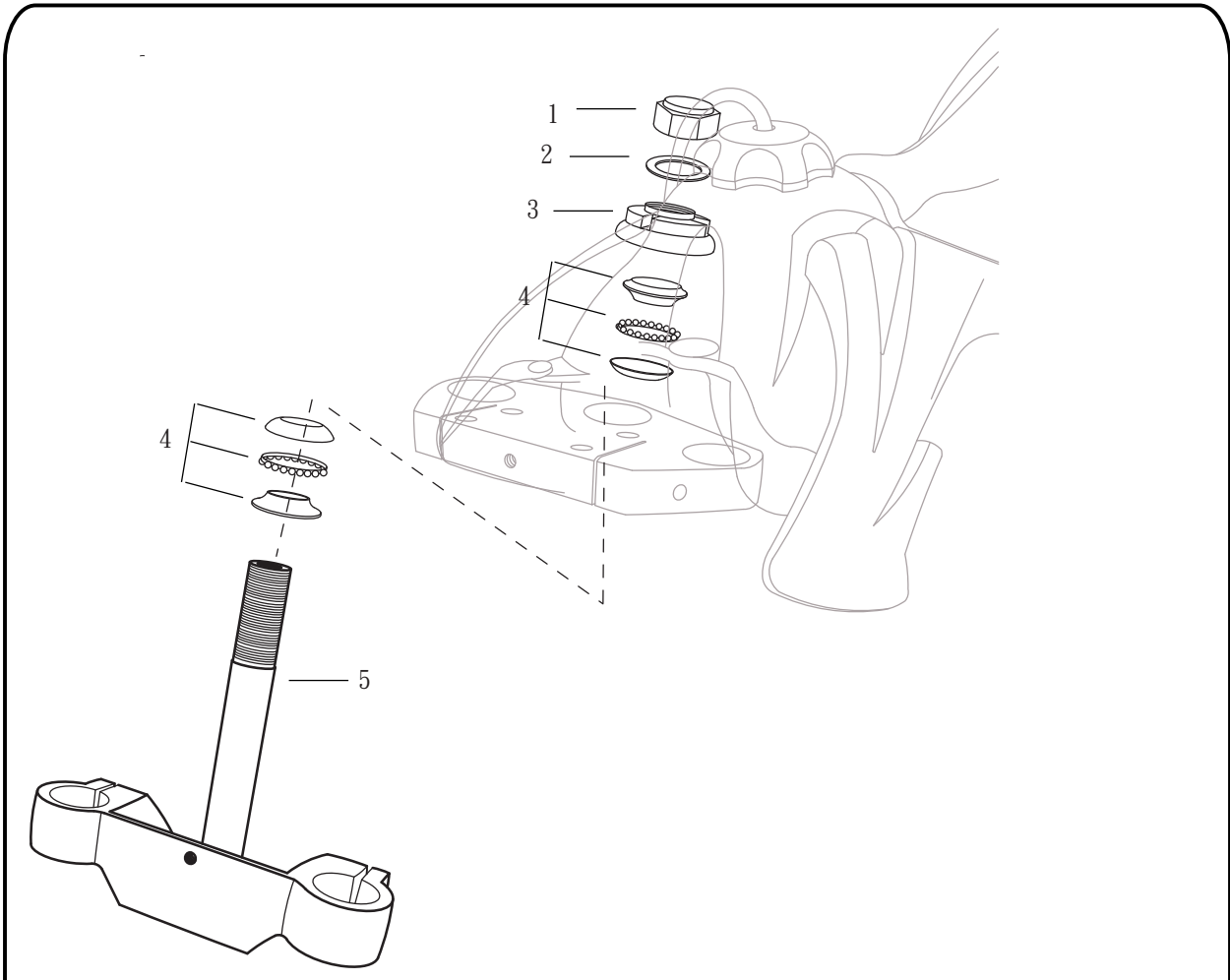

Order	Job / Part name	Q'ty	Remarks
			Remove the parts in the order listed.
1	NUT STEERING UPPER M22	1	
2	WASHER (STEEL).	1	
3	STEERING STEM LOCK NUT	1	
4	BEARING ASSY	1	
5	TRIPLE CLAMP(STEERING STEM) ASSY	1	
			For installation, reverse the removal procedure.

FRONT FORK

FRONT FORK

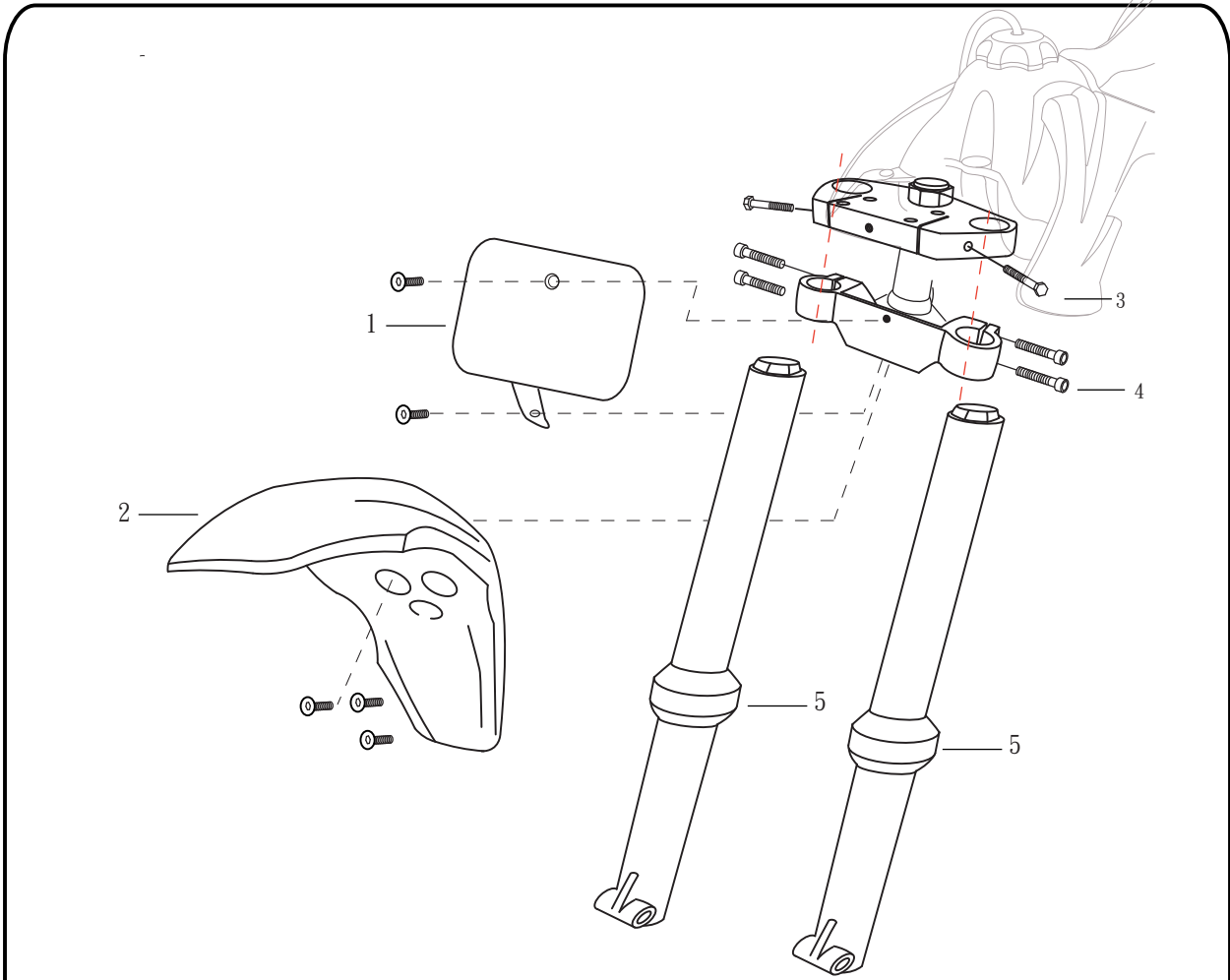

Order	Job / Part name	Q'ty	Remarks
			Remove the parts in the order listed.
1	FRONT NUMBER PLATE	1	
2	FRONT FENDER	1	
3	SCREW	2	
4	SCREW .	4	
5	FRONT.FORK ASSY	1	For installation, reverse the removal procedure.

FRONT FORK AND STEERING

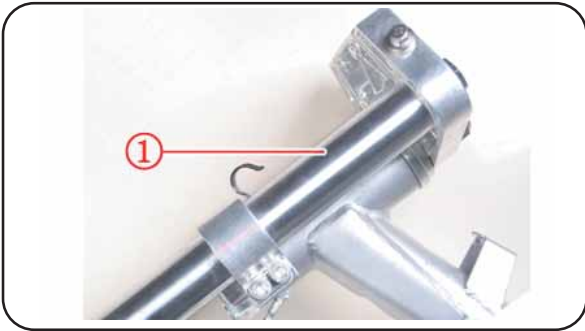

Installation

1. Install:
 - Front fork

NOTE:

- Temporarily tighten the pinch bolts (lower bracket).
- Do not tighten the pinch bolts (upper bracket) yet.

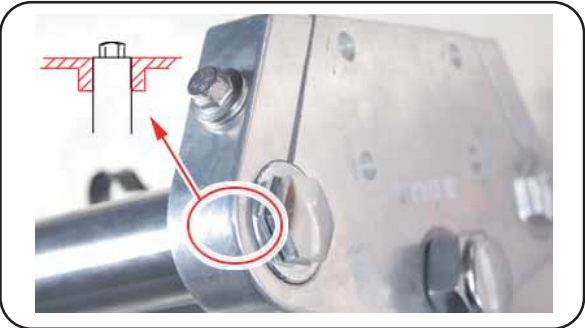

2. Tighten:
 - Front fork .

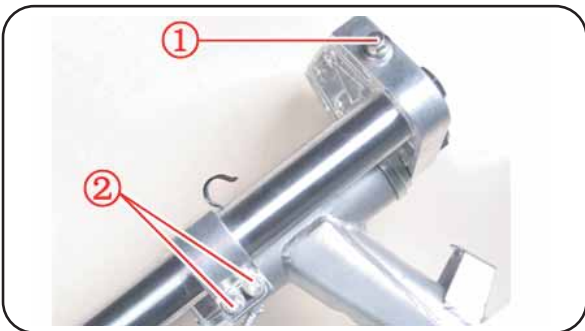

4. Tighten:
 - Pinch bolt (upper bracket)
 - Pinch bolt (lower bracket)

 15 Nm (1.5 m · kg)

 15 Nm (1.5 m · kg)

CAUTION:

Tighten the lower bracket to specified torque. If torqued too much, it may cause the front fork to malfunction.

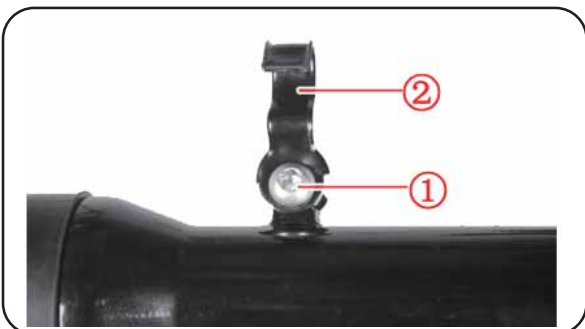

5. Install:
 - Brake hose holder
 - Bolt (brake hose holder)

 9 Nm (0.9 m · kg)

FRONT FORK AND STEERING

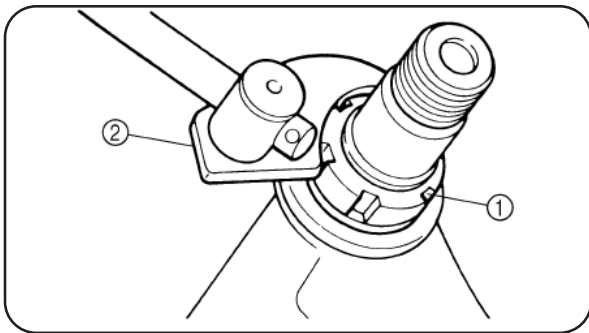

REMOVAL POINTS

Steering ring nut

1. Remove:
 - Steering ring nut
Use the steering nut wrench

▲ WARNING

Support the steering stem so that it may not fall down.

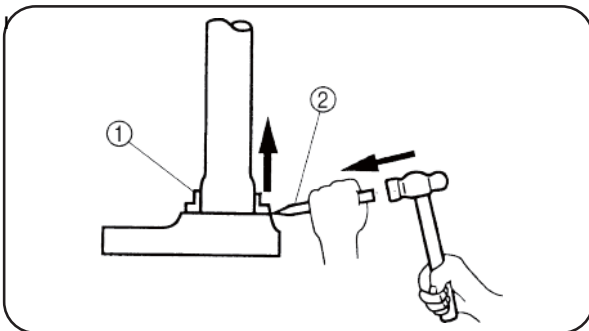

Lower bearing

1. Remove:
 - Lower bearing
Use the floor chisel .

CAUTION:

Take care not to damage the steering shaft thread.

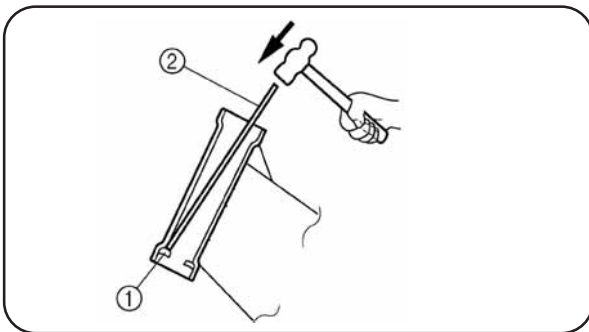

Ball race

1. Remove:
 - Ball race
Remove the ball race using long rod and the hammer.



INSPECTION

Steering stem

1. Inspect:
 - Steering stem
Bend/damage → Replace.

FRONT FORK AND STEERING



Bearing and ball race

1. Wash the bearings and ball races with a solvent.
2. Inspect:
 - Bearing
 - Ball race

Pitting/damage → Replace bearings and ball races as a set.

Install the bearing in the ball races. Spin the bearings by hand. If the bearings hang up or are not smooth in their operation in the ball races, replace bearings and ball races as a set.

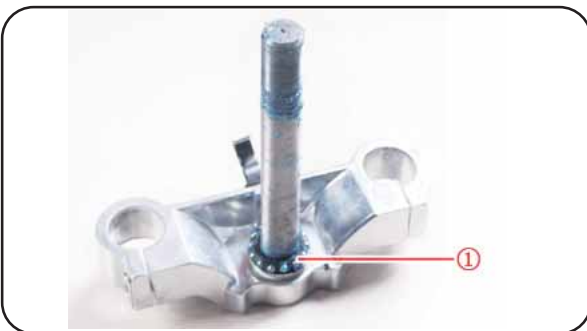

ASSEMBLY AND INSTALLATION

Lower bracket

1. Install:
 - Lower bearing

NOTE:

Apply the lithium soap base grease on the dust seal lip and bearing inner circumference.



2. Install:
 - Ball race
 - Upper bearing
 - Ball race cover

NOTE:

Apply the lithium soap base grease on the bearing and ball race cover lip.



3. Install:
 - Lower bracket

NOTE:

Apply the lithium soap base grease on the bearing, the portion a and thread of the steering stem.

FRONT FORK AND STEERING

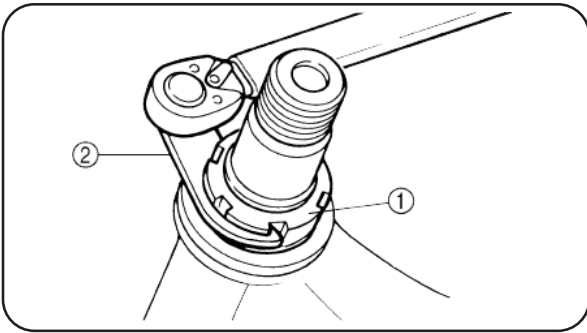

4. Install:

- Steering ring nut

 **30 Nm (3 m · kg)**

Tighten the steering ring nut using the steering nut wrench 2 .

Refer to “STEERING HEAD INSPECTION AND ADJUSTMENT” section in the CHAPTER 3.



5. Check the steering stem by turning it lock to lock. If there is any binding, remove the steering stem assembly and inspect the steering bearings.

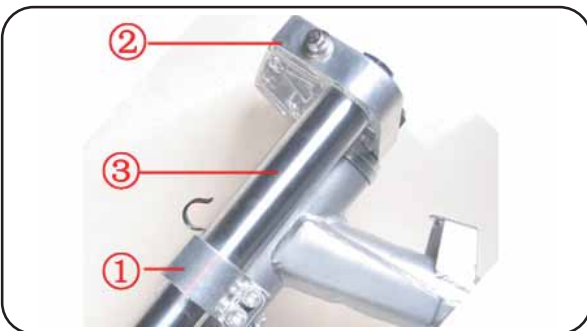

6. Install:

- Lower
- Upper bracket
- Front fork

NOTE:

- Temporarily tighten the pinch bolts (lower bracket).
- Do not tighten the pinch bolts (upper bracket) yet.

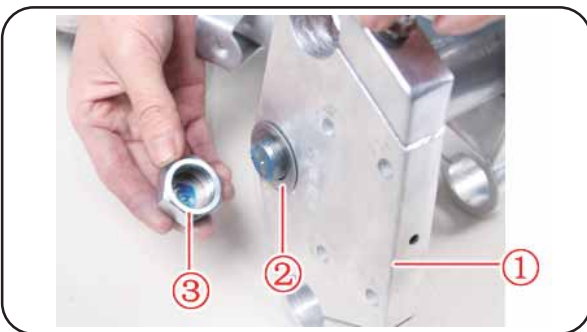

7. Install:

- Upper bracket
- Washer
- Steering stem nut

 **70 Nm (7.0 m · kg)**

8. After tightening the nut, check the steering for smooth movement. If not, adjust the steering by loosening the steering ring nut little by little.

FRONT FORK AND STEERING



9. Tighten:

- Pinch bolt (upper bracket)

 15 Nm (1.5 m · kg)

- Pinch bolt (lower bracket)

 15 Nm (1.5 m · kg)

CAUTION:

Tighten the lower bracket to specified torque. If torqued too much, it may cause the front fork to malfunction.

HANDLEBAR

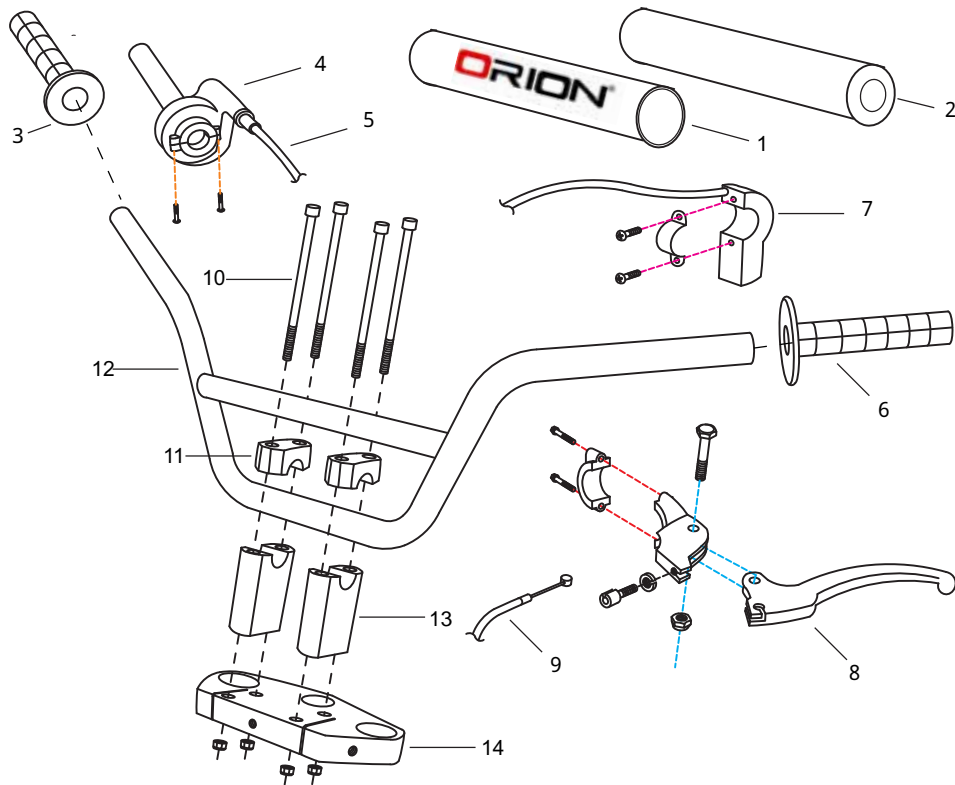

Order	Job / Part name	Q'ty	Remarks
			Remove the parts in the order listed.
1	CROSS BAR COVER	1	
2	CROSS BAR FOAM.	1	
3	GRIP .R	1	
4	THROTTLE HOUSING	1	
5	THROTTLE CABLE	1	
6	GRIP .L	1	
7	START SWITCH ASSY	1	
8	CLUTCH LEVER ASSY.	1	
9	CLUTCH CABLE ASSY	1	
10	SCREW WITH NUTM8X80	4	
11	RISER SET FOR HANDLEBAR	2	
12	HANDLEBAR	1	
13	RISER SET FOR HANDLEBAR	2	
14	UPPER TRIPLECLAMP	1	
			For installation, reverse the removal procedure.

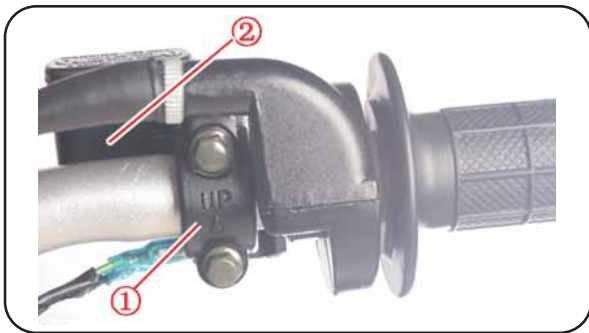

REMOVAL POINTS

Brake master cylinder

1. Remove:
 - Brake master cylinder bracket
 - Brake master cylinder

CAUTION:

- Do not let the brake master cylinder hang on the brake hose.
- Keep the brake master cylinder cap side horizontal to prevent air from coming in.

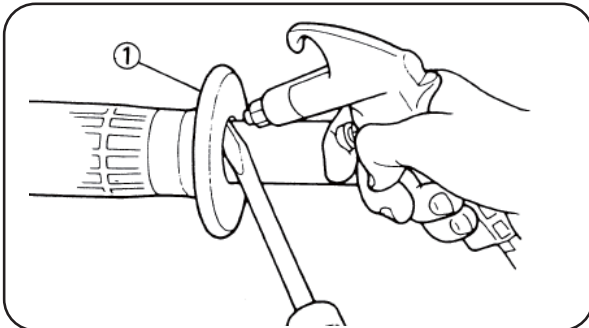

Grip

1. Remove:
 - Grip

NOTE:

Blow in air between the handlebar or tube guide and the grip. Then remove the grip which has become loose.

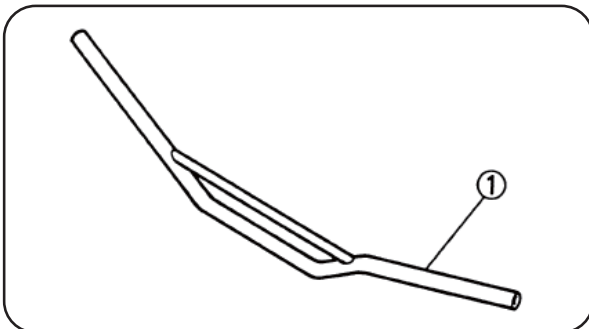

INSPECTION

Handlebar

1. Inspect:
 - HandlebarBends/cracks/damage → Replace.

▲ WARNING

Do not attempt to straighten a bent handlebar as this may dangerously weaken the handlebar.

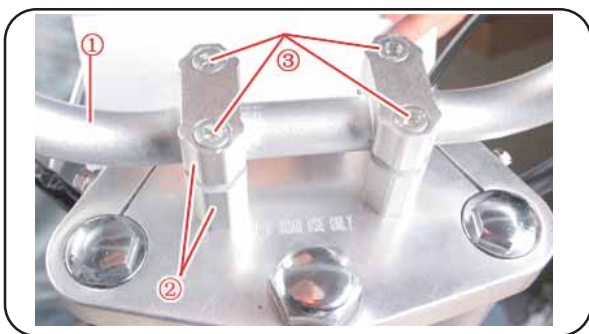

ASSEMBLY AND INSTALLATION Handlebar

1. Install:
 - Handlebar
 - Handlebar upper holder
 - Bolt (handlebar upper holder)

 25 Nm (2.5 m · kg)

NOTE:

- The handlebar upper holder should be installed with the punched mark a forward.
- First tighten the bolts on the front side of the handlebar upper holder, and then tighten the bolts on the rear side.

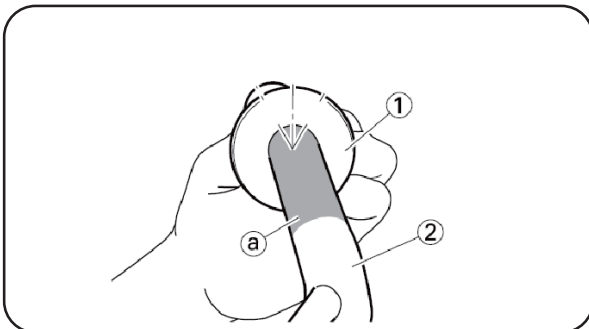
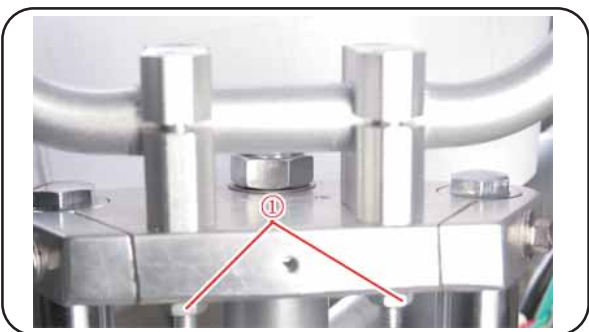

2. Install:
 - Left grip

Apply the adhesive to the handlebar .

NOTE:

- Before applying the adhesive, wipe off grease or oil on the handlebar surface (a) with a lacquer thinner.

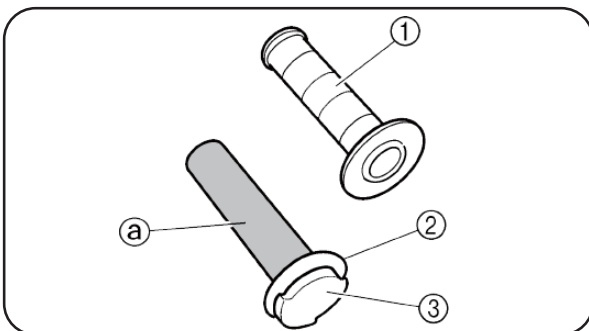

3. Install:
 - Right grip
 - Collar

Apply the adhesive on the tube guide .

NOTE:

- Before applying the adhesive, wipe off grease or oil on the tube guide surface (a) with a lacquer thinner.



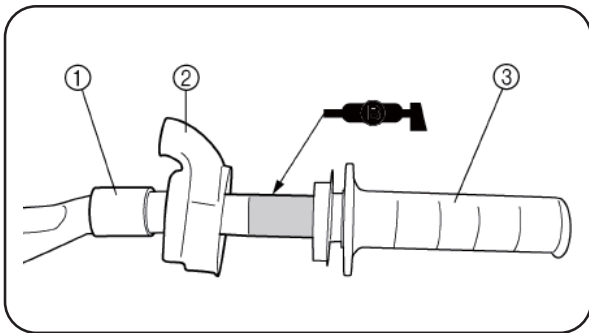

4. Install:
- Collar
 - Grip cap cover
 - Throttle grip

NOTE:

Apply the lithium soap base grease on the throttle grip sliding surface.

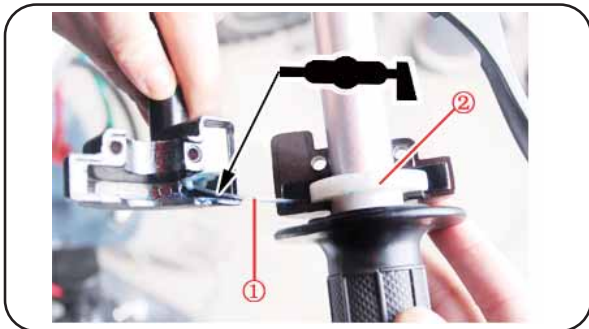

5. Install:
- Throttle cables
To tube guide

NOTE:

Apply the lithium soap base grease on the throttle cable end and tube guide cable winding portion.

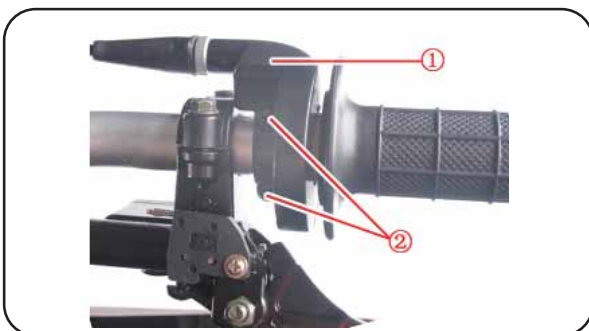

6. Install:
- Throttle cable cap
 - Screw (throttle cable cap)

 4 Nm (0.4 m · kg, 2.9 ft · lb)

▲ WARNING

After tightening the screws, check that the throttle grip moves smoothly. If it does not, retighten the bolts for adjustment.

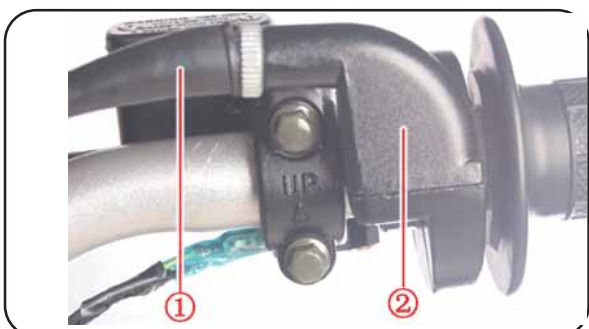
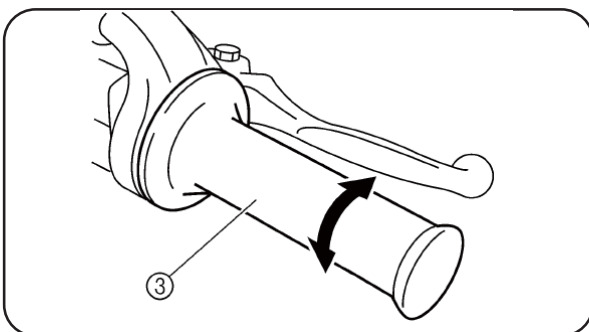

7. Install:
- Grip cap cover
 - Cover (throttle cable cap)

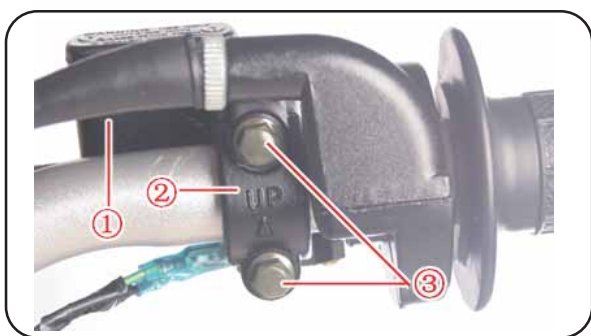

8. Install:
- Brake master cylinder
 - Brake master cylinder bracket
 - Bolt (brake master cylinder bracket)

 **9 Nm (0.9 m • kg)**

NOTE:

- Install the bracket so that the arrow mark a faces upward.
- First tighten the bolt on the upper side of the brake master cylinder bracket, and then tighten the bolt on the lower side.

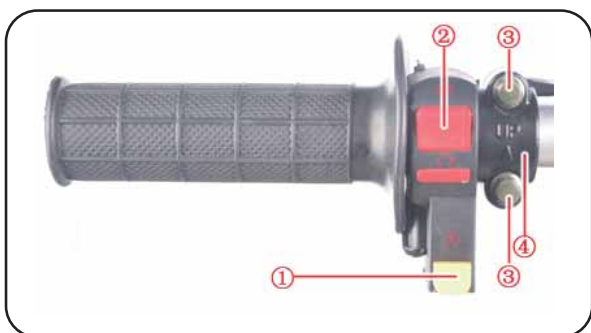

9. Install:

- Engine start button
- Engine stop switch
- Bolt (clutch lever holder)

 **9 Nm (0.9 m • kg)**

- Clutch lever holder

- Screw (Engine start button)

 **4 Nm(0.4 m • kg)**

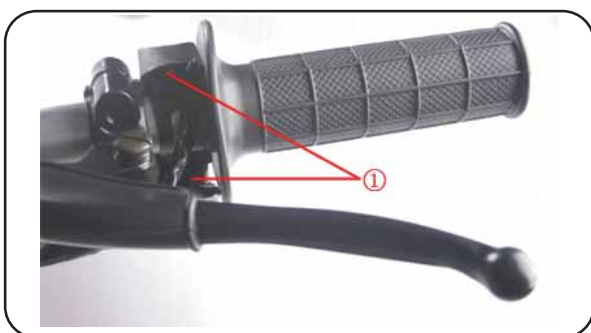

10. Install:

- Bolt (clutch lever)

NOTE:

Apply the lithium soap base grease on the clutch cable end .

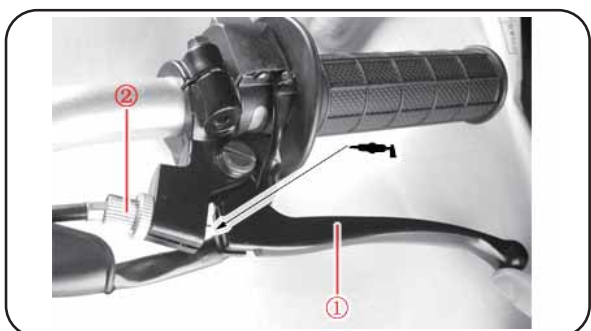

11. Adjust:

- Clutch lever free play
Refer to “CLUTCH ADJUSTMENT” section in the CHAPTER 3.
- Hot starter lever free play

SWINGARM AND REAR SHOCK ABSORBER

SWINGARM AND REAR SHOCK ABSORBER

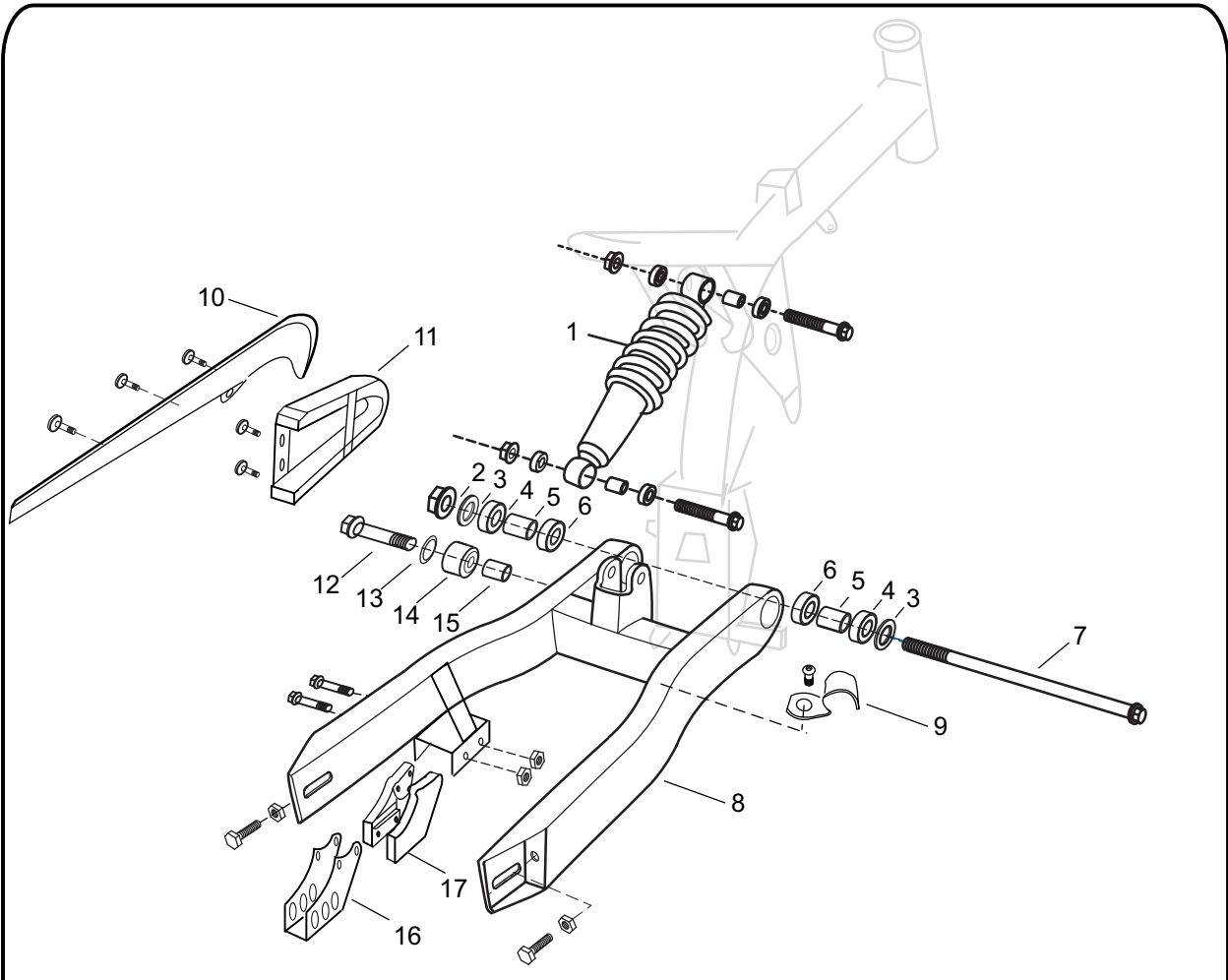

Order	Job / Part name	Q'ty	Remarks
			Remove the parts in the order listed.
1	REAR SHOCK	1	
2	NUT	1	
3	WSHER	2	
4	NEEDLE BEARING	2	
5	BUSHING	2	
6	NEEDLE BEARING	1	
7	MIDDLE AXLE BOLT	1	
8	REAR SWING ARM ASSY	1	
9	CLIP	1	
10	CHAIN GUARD	1	
11	REAR FORK DUST COVER	1	
12	BOLT	1	
13	WSHER	1	
14	CHAIN ROLLER	1	
15	COLLAR	1	
16	CHAIN GUIDE-BRACKET	1	
17	LT.CHAIN-GUIDE BRACKET (set)	1	
			For installation, reverse the removal procedure.

REAR SHOCK ABSORBER AND SWINGARM

REMOVING THE REAR SHOCK ABSORBER ASSEMBLY

1. Stand the motorcycle on a level surface.

⚠ WARNING

Securely support the motorcycle so that there is no danger of it falling over.

NOTE:

Place the motorcycle on a suitable stand so that the rear wheel is elevated.

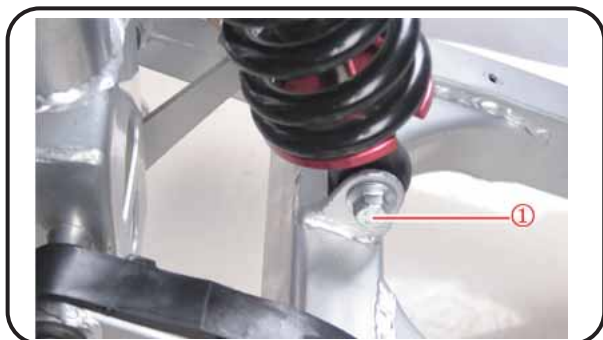

2. Remove:

- rear shock absorber assembly lower bolt ①

NOTE:

While removing the rear shock absorber assembly lower pin, hold the swingarm so that it does not drop down.



3. Remove:

- rear shock absorber assembly upper bolt ①
- rear shock absorber assembly

NOTE:

Raise the swingarm and then remove the rear shock absorber assembly from between the swingarm and relay arm.

REMOVING THE DRIVE CHAIN

1. Stand the motorcycle on a level surface.

⚠ WARNING

Securely support the motorcycle so that there is no danger of it falling over.

NOTE:

Place the motorcycle on a suitable stand so that the rear wheel is elevated.

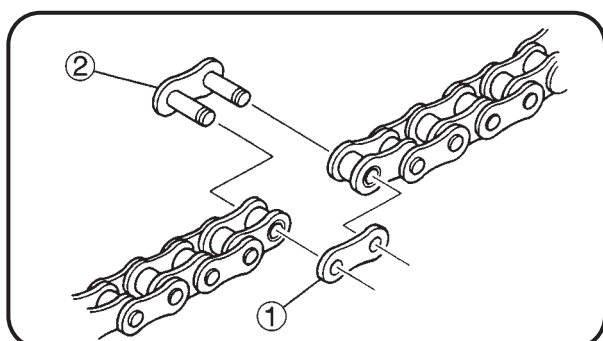

2. Remove:

- chain cover

3. Remove:

- master link clip
(with interlocking slip-joint pliers)

4. Remove:

- master link plate ①
- master link ②

5. Remove:

- drive chain

REAR SHOCK ABSORBER AND SWINGARM

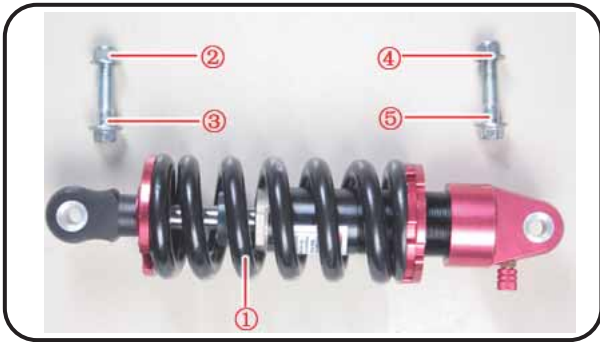

CHECKING THE REAR SHOCK ABSORBER ASSEMBLY

1. Check:

- rear shock absorber rod
Bends/damage → Replace the rear shock absorber assembly.
- rear shock absorber
Gas leaks/oil leaks → Replace the rear shock absorber assembly.
- spring
Damage/wear → Replace the rear shock absorber assembly.
- bolts
Bends/damage/wear → Replace.

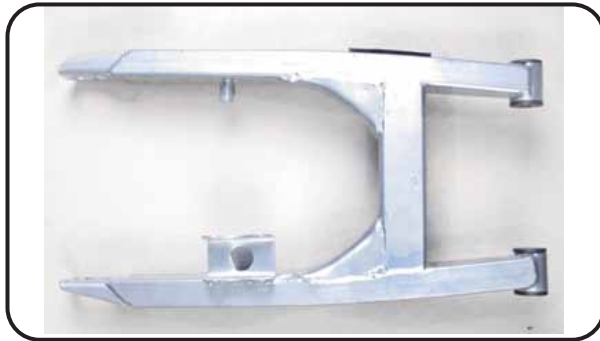

CHECKING THE SWINGARM

1. Check:

- swingarm
Bends/cracks/damage → Replace.

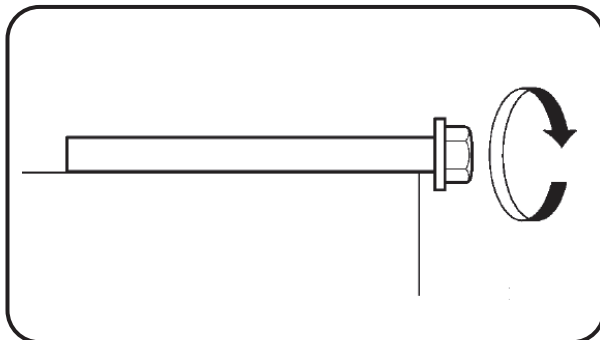

2. Check:

- pivot shaft
Roll the pivot shaft on a flat surface.
Bends → Replace.

⚠ WARNING

Do not attempt to straighten a bent pivot shaft.



3. Wash:

- pivot shaft
- spacer
- bearings



**Recommended cleaning solvent
Kerosine**

REAR SHOCK ABSORBER AND SWINGARM

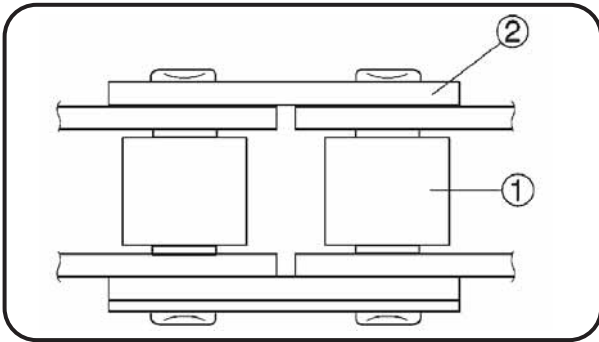

4. Check:

- drive chain rollers ①
Damage/wear → Replace the drive chain.
- drive chain side plates ②
Damage/wear → Replace the drive chain.
Cracks → Replace the drive chain and make sure that the battery breather hose is properly routed away from the drive chain and below the swingarm.

5. Lubricate:

- drive chain



Recommended lubricant
Engine oil or chain lubricant
suitable for non-O-ring chains

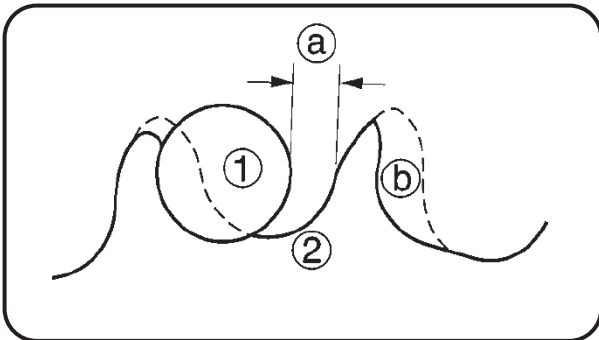

6. Check:

- drive sprocket
- rear wheel sprocket
More than 1/4 tooth (a) wear → drive chain sprockets as a set.
Bent teeth → Replace the drive chain sprockets as a set.

(b) Correct

① Drive chain roller

② Drive chain sprocket

INSTALLING THE REAR SHOCK ABSORBER ASSEMBLY

1. Install:

- rear shock absorber assembly

40 Nm (4.0 m • kg)

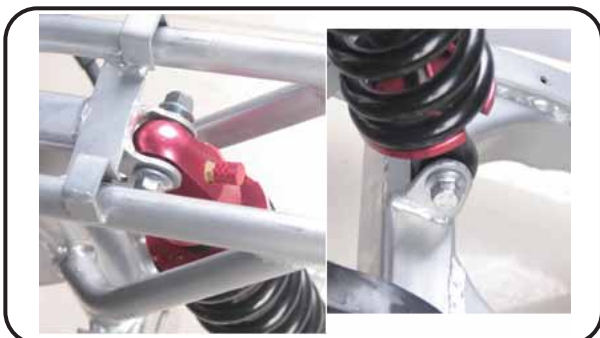

NOTE:

When installing the rear shock absorber assembly, lift up the swingarm.

REAR SHOCK ABSORBER AND SWINGARM



INSTALLING THE SWINGARM

1. Lubricate:
 - bearings
 - spacers
 - pivot shaft



Recommended lubricant
Molybdenum disulfide grease

2. Install:
 - Swingarm  **50 Nm (5.0 m•kg)**
3. Install
 - rear shock absorber assembly
 - rear wheelRefer to "INSTALLING THE REAR SHOCK ABSORBER ASSEMBLY" and "REAR WHEEL".
4. Adjust:
 - drive chain slackRefer to "ADJUSTING THE DRIVE CHAIN SLACK" in chapter 3.



Drive chain slack
30 ~ 50 mm

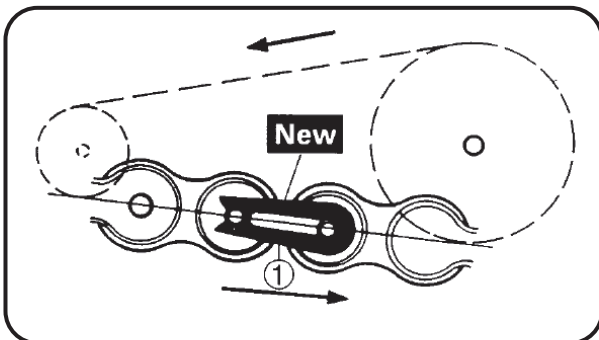
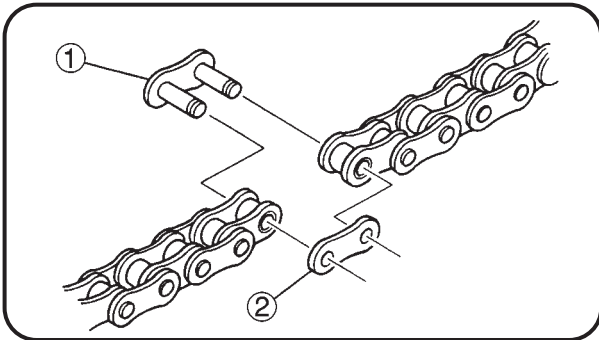

INSTALLING THE DRIVE CHAIN

1. Lubricate:
 - drive chain
 - master link (New)



Recommended lubricant
Engine oil or chain lubricant
suitable for non-O-ring chains

2. Install:
 - master link ①
 - master link plate ②
3. Install:
 - master link clip ①

CAUTION:

- The closed end of the master link clip must face in the direction of drive chain rotation.
- Never install a new drive chain onto worn drive chain sprockets; this will dramatically shorten the drive chain's life.

4. Adjust:
 - drive chain slackRefer to "ADJUSTING THE DRIVE CHAIN SLACK" in chapter 3.



Drive chain slack
30 ~ 50 mm

REAR SHOCK ABSORBER AND SWINGARM

CAUTION:

A drive chain that is too tight will overload the engine and other vital parts, and one that is too loose can skip and damage the swingarm or cause an accident. Therefore, keep the drive chain slack within the specified limits.

ELECTRICAL COMPONENTS AND WIRING DIAGRAM

ELECTRICAL

ELECTRICAL COMPONENTS AND WIRING DIAGRAM

ELECTRICAL COMPONENTS

- 1 Starter Solenoid
- 2 Rectifier/Regulator
- 3 Battery
- 4 CDI magneto
- 5 Spark plug
- 6 Ignition coil
- 7 CDI unit

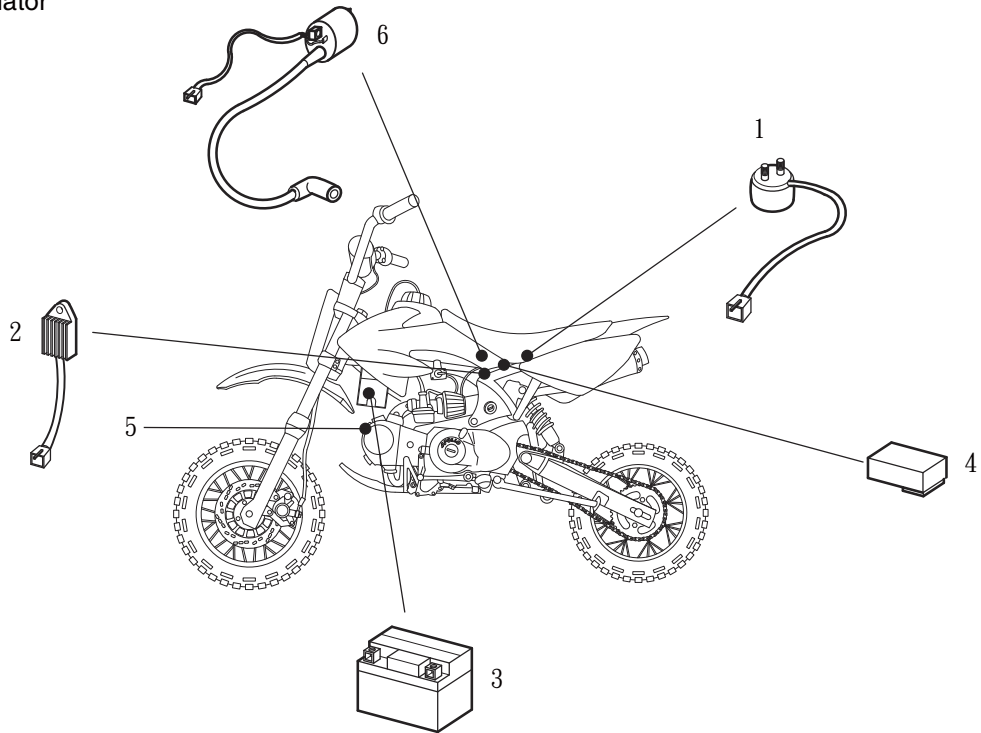

WIRING DIAGRAM

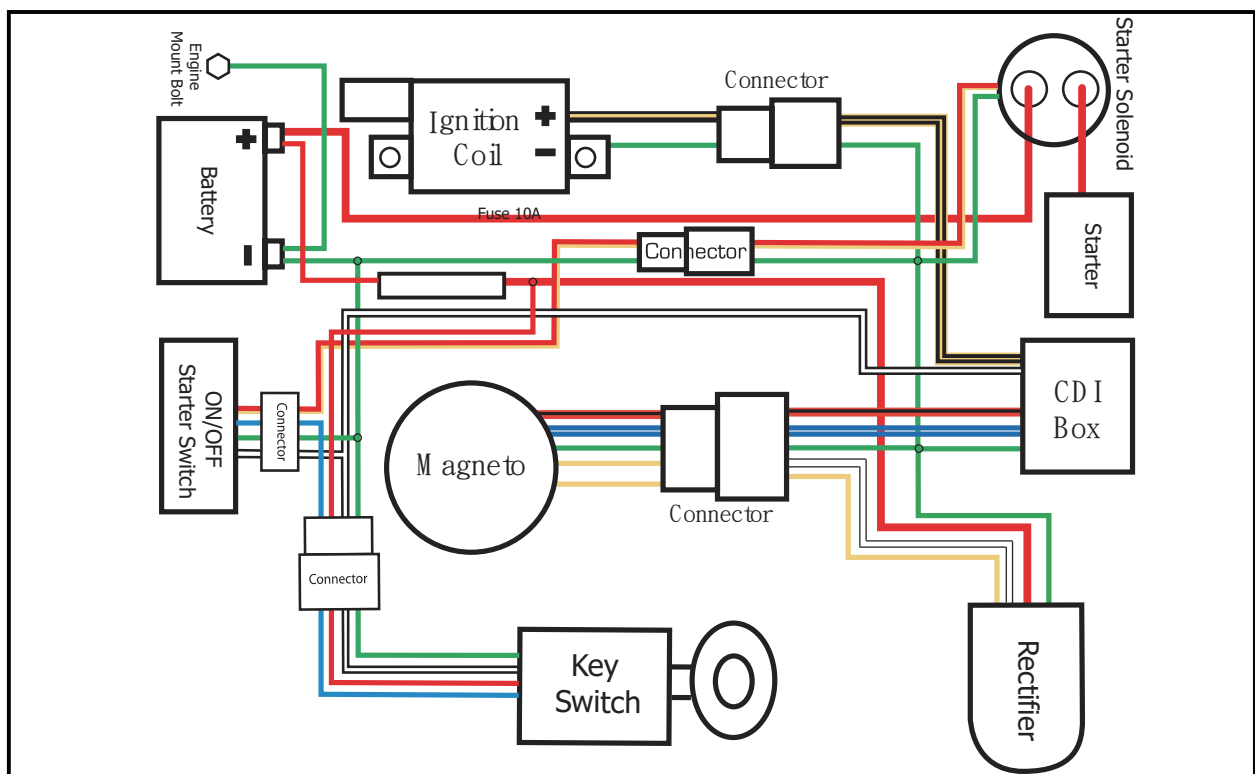

IGNITION SYSTEM

INSPECTION STEPS

Use the following steps for checking the possibility of the malfunctioning engine being attributable to ignition system failure and for checking the spark plug which will not spark.

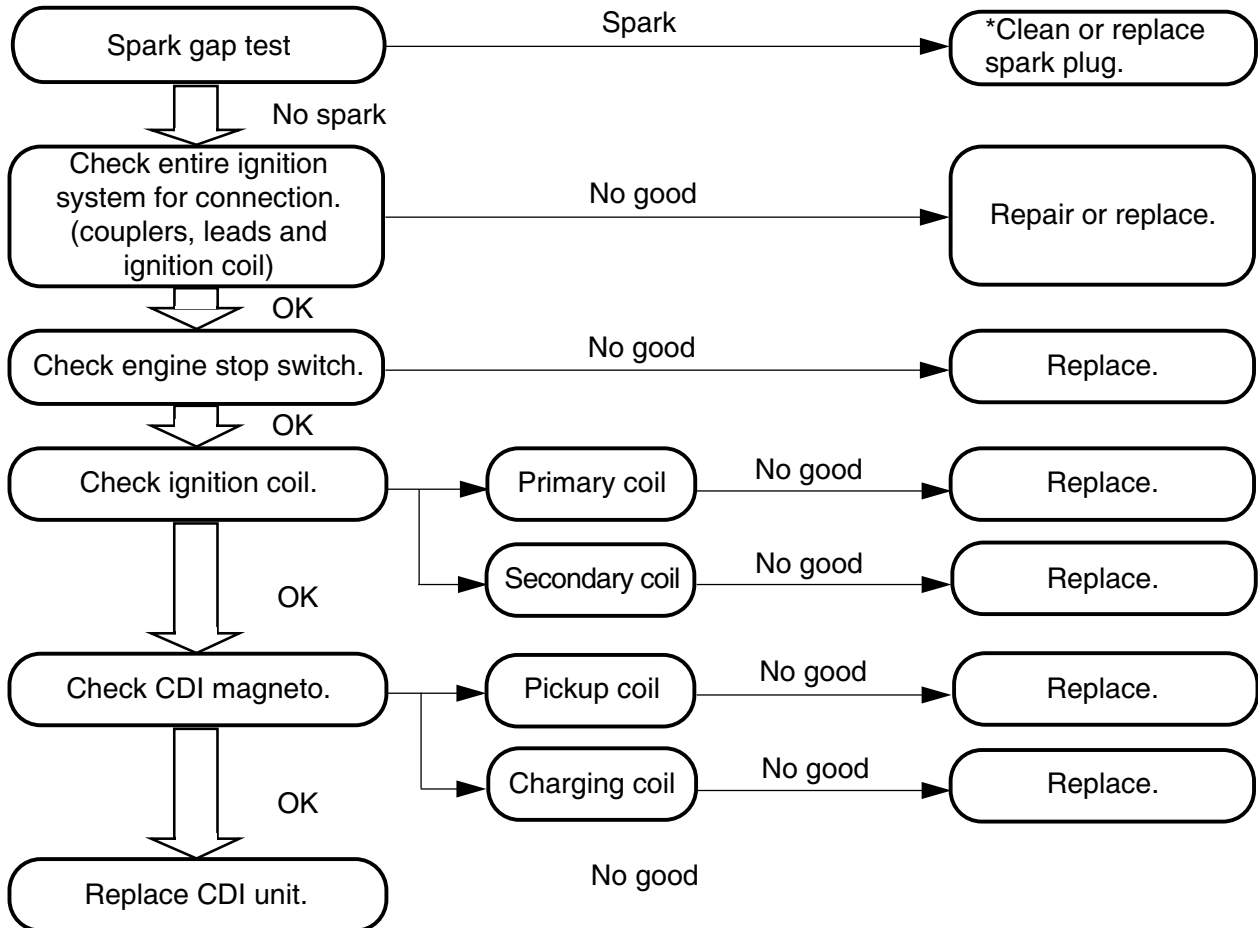

*marked: Only when the ignition checker is used.

NOTE:

- Remove the following parts before inspection.
 - 1) Seat
 - 2) Fuel tank
- Use the following special tools in this inspection.

IGNITION SYSTEM

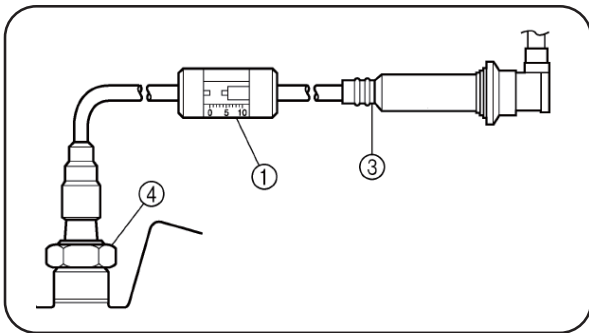

SPARK GAP TEST

1. Disconnect the spark plug cap from spark plug.
2. Remove the ignition coil cap.
3. Connect the dynamic spark tester (ignition checker) as shown.
 - Ignition coil
 - Spark plug

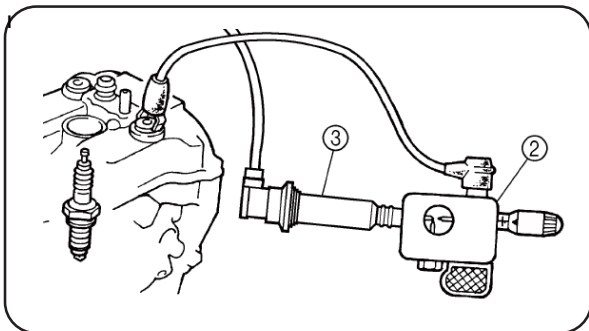

4. Kick the kickstarter crank.
5. Check the ignition spark gap.
6. Start engine, and increase spark gap until misfire occurs.



**Minimum spark gap:
6.0 mm**

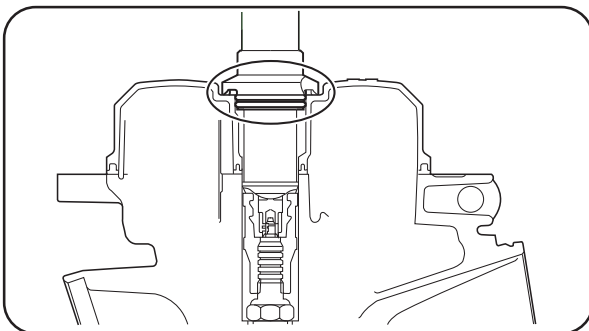

COUPLERS, LEADS AND IGNITION COIL CONNECTION INSPECTION

1. Check:
 - Couplers and leads connection
Rust/dust/looseness/short-circuit → Repair or replace.
 - Ignition coil and spark plug as they are fitted
Push in the ignition coil until it closely contacts the spark plug hole in the cylinder head cover.

ENGINE START / STOP SWITCH INSPECTION

1. Inspect:
 - Engine stop switch conduct

Tester (+) lead → Black/White lead 1
Tester (-) lead → Green lead 2

	B/W 1	G 2	Tester selector position
PUSH IN	○	○	Ω × 1
FREE			

No continuous while being pushed → Replace.
Continuous while being freed → Replace.

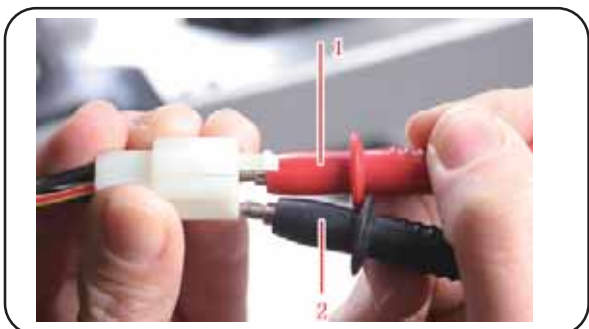

IGNITION SYSTEM

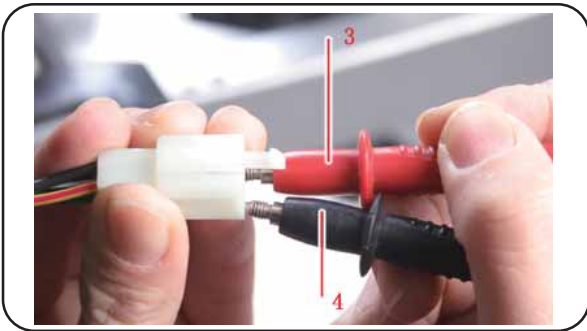



2. Inspect:

- Engine start switch conduct

Tester (+) lead → **Red/Yellow lead** 3

Tester (-) lead → **Black lead** 4

	B	R/Y	Tester selector position
	4	3	
PUSH IN			$\Omega \times 1$
FREE			

No continuous while being pushed → Replace.

Continuous while being freed → Replace.